



*Solutions for*

# **ROAD CONSTRUCTION**

 **Bonfiglioli**





# BONFIGLIOLI SOLUTIONS FOR ROAD CONSTRUCTION



## Travel drives

700C Series

## Track drives

700CT Series

## Drum drives

F Series

## Cutter drives

700C Series

FA Series

## Wheel drives

600 Series

600 Series for AWD graders

600W2/3 Series

600 Y3 Series

## The most reliable solutions for Road Construction

Bonfiglioli's broad and diversified product range, is able to satisfy every application requirement for road construction and maintenance machinery, including:

- milling machines
- road compactors, in all versions
- road pavers

Each machine has its own specific structural and duty characteristics, which Bonfiglioli is well aware of, thanks to over 40 years of experience in the industry, working in close partnership with leading manufacturers on the market.

Bonfiglioli is thus able to offer a range of products perfectly tailored to meet a broad variety of drive specifications: from highly compact track drives for milling machines to final drives for road compactors, including wheel drives for road pavers, with 2 speed shift options: slow for operating on work sites and fast for transfer between sites.

A vast range of customised solutions and extensive expertise in the industry, make Bonfiglioli the ideal partner for all manufacturers of road machinery.

Bonfiglioli also provides solutions for:



BUILDING  
CONSTRUCTION



CONSTRUCTION  
INDUSTRY



EARTH-MOVING  
MACHINES

[www.bonfiglioli.com](http://www.bonfiglioli.com)



## TRAVEL DRIVES



### 700C Series

Bonfiglioli 700C series units are unsurpassed by any crawler or milling machines. Thanks to compact, rugged design, high torque and load capabilities, and optional mechanical lifetime seals, these solutions are the best possible option for the machine. All units are available with a fail-safe parking brake and most have the option of cartridge type fixed or variable systems.



HYDRAULIC SOLUTIONS



COLD MILLING MACHINES



CRUSHERS & SCREENERS



PAVERS



REFUSE COMPACTORS



SOIL COMPACTORS



TANDEM VIBRATORY ROLLERS

#### Input speed

- up to 4,000 rpm

#### Brake options

- Hydraulically released parking brake on request

#### Applicable motors

- Cartridge axial piston hydraulic motors
- Flanged axial piston hydraulic motors
- Hydraulic orbit motors

#### Key features

- Rotating housing
- Rugged design
- High torque capacity
- High load capacity
- Mechanical lifetime seals
- Compact design

#### Torque (Nm)

700 C	1,000
701 C	2,200
703 C	4,000
705 C	10,000
706 C	18,000
707 C	26,000
709 C	30,000
710 C	36,000
711 C	45,000
713 C	60,000
715 C	85,000
716 C	100,000



Type	Range of ratios	Max. input speed	Hydraulic motor drive <sup>(1)</sup>	Braking torque	Min. opening pressure	Weight
	1:	RPM		Nm	bar	kg
700 C	5.25	1000	LS	140 - 250	15 - 25	20
701 C	6.2	1000	LS	250 - 350	20 - 30	25
703 C	19-40	3500	HS	210	18	42
705 C	22-53	3500	HS	220 - 310	10 - 20	60
706 C	68-173	3500	HS	250 - 500	10 - 20	95
707 C	55-120	3500	HS	250 - 500	10 - 20	135
709 C	55-147	3500	HS	250 - 600	10 - 20	180
710 C	55-166	3500	HS	250 - 600	10 - 20	200
711 C	71-163	3500	HS	400 - 800	10 - 20	270
713 C	56-147	3000	HS	400 - 800	10 - 20	310
715 C	62-156	3000	HS	600 - 1000	10 - 20	350
716 C	83-174	3000	HS	800 - 1200	10 - 20	400

(1) LS = Low speed motor / HS = High speed motor

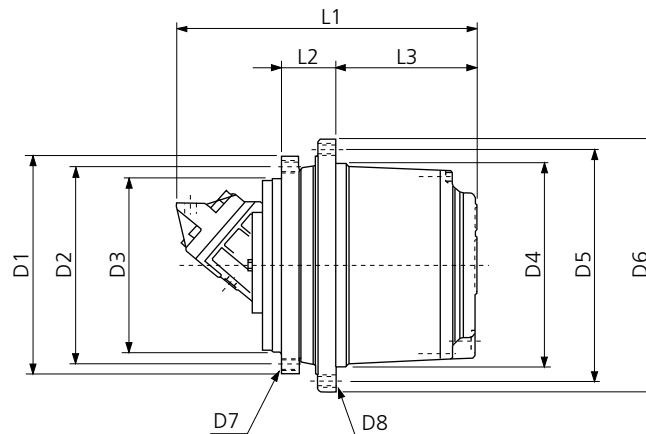

Type	D1	D2	D3	D4	D5	D6	D7	D8	L1	L2	L3
700 C	195	175	155	160	180	200	M10x1.5 no.8	M10x1.5 no.8	Based on the motor type	40	80
701 C	230	200	180	190	210	230	M10x1.5 no.8	M10x1.5 no.8		40	105
703 C	270	230	190	200	240	280	M16x2 no.8	M20x1.5 no.8		72	128
705 C	270	230	190	220	260	300	M16x2 no.12	M16x2 no.16		72	158
706 C	330	300	270	280	330	370	M16x2 no.18	M16x2 no.18		115	190
707 C	317	285	240	300	340	370	M20x2.5 no.20	M16x2 no.20		82	233
709 C	375	340	300	330	370	400	M20x2.5 no.16	M16x2 no.30		91	243
710 C	375	340	300	350	400	435	M20x2.5 no.16	M20x2.5 no.16		91	243
711 C	425	325	290	410	455	490	M20x2.5 n°24	M20x2.5 n°24		110	265
713 C	425	325	290	410	455	490	M20x2.5 no.24	M20x2.5 no.24		110	280
715 C	500	460	420	460	510	550	M20x2.5 no.24	M20x2.5 no.24		130	315
716 C	500	460	420	460	500	550	M24x3 no.24	M18x1.5 no.36		165	308

## TRACK DRIVES



### 700CT Series

Extremely compact, lightweight, efficient and smooth to operate, 700CT Series track drives are powered by integrated axial piston hydraulic motors.



HYDRAULIC SOLUTIONS



PAVERS



ROAD  
COMPACTOR

#### Input speed

- up to 3,500 rpm

#### Brake options

- Hydraulically released spring-applied parking brake, with external independent port

#### Motors

- Fixed or dual displacement, with flushing valve circuit, suitable for closed loop applications

#### Motor options

- Speed sensor mounting

#### Key features

- Rotating output flange with large PCD suitable for sprocket
- Rugged design
- High torque capacity
- High load capacity
- Mechanical lifetime seals
- Compact design

#### Torque (Nm)

702 CT	3,500
704 CT	5,000
705 XT	12,000
706 CT	12,500



Type	Weight	Output torque	Ratios	Motor type
	tons	Nm	1:	
702 CT	2.5 ÷ 3.5	3,500	15 ÷ 22	High speed
704 CT	3.5 ÷ 5	5,000	18	
705 XT	5 ÷ 7	12,500	25 ÷ 30	Axial piston
706 CT	7 ÷ 9	14,500	53	Axial piston

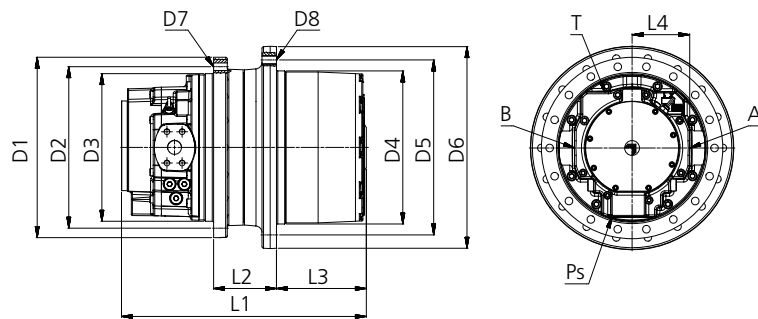

XT version

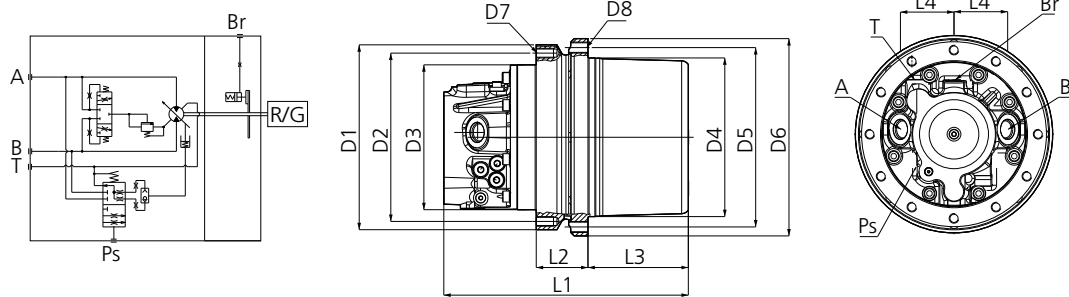

CT version

Type	D1	D2	D3	D4	D5	D6	D7	D8	L1	L2	L3	L4	A-B	T	PS
702 CT	270	240	210	210	245	275	M16x2 no.8	M16x2 no.12	340	153	70	77	1" 1/16-12 UNF	3/4"-16 UNF	9/16"-18 UNF
704 CT	268	244	210	230	260	286	M14x2 no.12	M16x2 no.8	355	75	146	77			
705 XT	335	300	270	250	285	320	M16 no.12	M16 no.12	426	85	142	100	1" UNF	7/8"-14 UNF	
706 CT	335	300	270	280	330	370	M16 no.18	M16 no.18	448	115	165	100			

## DRUM DRIVES



### F Series

The F Series is perfectly suited to any crawler and milling machine. Thanks to compact, rugged design, high torque and load capabilities, and optional mechanical lifetime seals, these solutions are the best possible option for these machines. All units are available with a fail-safe parking brake and for most cartridge type fixed or variable systems. Different disengagement systems are available on demand for all the sizes.



HYDRAULIC SOLUTIONS



COLD MILLING MACHINES



CRUSHERS & SCREENERS



PAVERS



SOIL COMPACTORS



TANDEM VIBRATORY ROLLERS

### Input speed

- up to 4,000 rpm

### Main options

- Mechanical disconnect device

### Key features

- Integrated hydraulic motor
- 2-stage planetary drive
- 2-speed hydraulic motor
- Counterbalance travel valve
- High pressure relief valves
- 2-speed shift function by external pilot control
- 2-speed shift function by external pilot control
- Automatically released parking brake

### Torque (kNm)

FD20	20
F30	30
F40	40
F55	55
F80	80
F80XR	80
F100	100
F100XR	100





Type	Ratios	Output Torque	Motor Displacement	Weight	Approx. Weight of Machine
	1:	kNm	ccm	kg	tons
FD20	81 ÷ 228	20	28-45	72	7 ÷ 9
F30	61 ÷ 305	30	28-60	94	9 ÷ 12
F40	61 ÷ 181	40	55-60	115	12 ÷ 16
F55	63 ÷ 185	55	80	165	16 ÷ 18
F80	61 ÷ 206	80	80-160	240	18 ÷ 20
F80XR	61 ÷ 206	80	80-160	240	18 ÷ 20
F100	77 ÷ 226	100	107-160	330	20 ÷ 25
F100XR	77 ÷ 226	100	104-160	341	20 ÷ 25

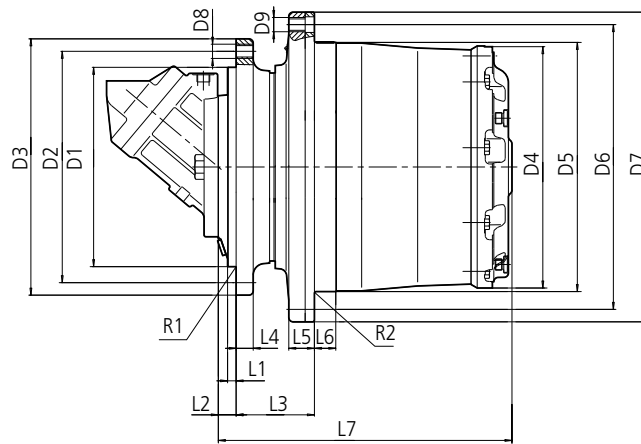

Type	L1	L2	L3	L4	L5	L6	L7	R1	R2	D1	D2	D3	D4	D5	D6	D7	D8	D9	Qty. D8/D9
FD20	10	41	75	15	28	25	300	2.5	2.5	240	275	304	250	270	305	335	M16x2	M16x2	18/18
F30	13	25/22	75	15	29	25	323/320	2.5	2.5	240	275	304	269	270	305	335	M16x2	M16x2	18/18
F40	16	16	91	21	34	26	338	2.5	2.5	240	285	320	294	295	335	370	M20x1.5	M20x1.5	20/20
F55	12	25	110	24	36	30	413	1	2.5	280	325	360	340	350	400	435	M20x1.5	M20x1.5	24/20
F80	20	35	90	22	37	24	415	4	2.5	330	370	410	374	400	450	490	M24x2	M24x2	20/20
F80XR	20	35	90	22	37	23	414.5	4	2.5	330	370	410	374	400	450	490	M20x1.5	M20x1.5	20/20
F100	35/37	35/37	165	28	53	43	461/463	10 (12)/60	5	390	460	500	407	408	460	500	M24x2	M24x2	30/24
F100XR	22	35	148	29	53	30	463	2.5	2.5	380	430	480	407	430	480	520	M24x3	M24x3	20/20

## CUTTER DRIVES



### 700C Series

Dual-stage planetary drive units with integrated pulley support designed for cold planers and milling machines with engine power from 200 to 550 kW and rotor width from 1.0 to 2.5 m. The offset input option ensures higher machine productivity due to increased cutting depth. The unique integrated cooling system allows greater performance, easier system maintenance and optimal level of reliability.



HYDRAULIC SOLUTIONS



COLD MILLING  
MACHINES

### Key features

- Dual stage planetary reduction
- Integrated pulley support shaft with reinforced bearings
- Optimized housing design for improved lubrication performance
- Offset input available for increased cutting depth
- Integrated cooling system (optional)

### Torque (Nm)

710 C2 H	20,000
713 C2 H	25,000
716 C2 H	45,000



Type	Ratios	Max Cutting Torque	Max Input Power	Bearings Load Ratings		Version
				C dyn. (kN)	C0 stat. (kN)	
710 C2 H	16	20,000	200	360	760	Offset
713 C2 H	16.4 - 19 - 22.9	25,000	220	473	950	Offset
716 C2 H	18.5 - 21.8	45,000	380	484	1,000	In line

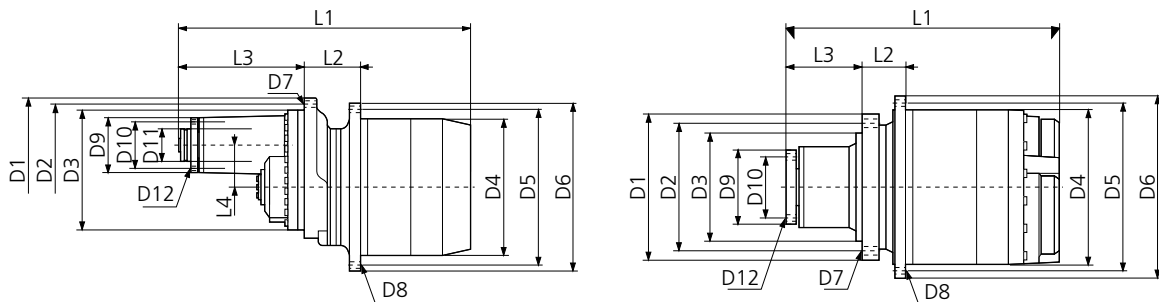

Type	Vers.	D1	D2	D3	D4	D5	D6	D7	D8	D9	D10	D11	D12	L1	L2	L3	L4
710 C2 H	Offset	350	310	270	350	400	440	M20x2.5 no.24	Ø22 no.22	145	122	80	M12x1.75 no.8	811	195	265	95
713 C2 H	Offset	420	385	350	400	450	490	M20x2.5 no.23	Ø22 no.23	160	130	95	M12x1.75 no.8	834	160	325	120
716 C2 H	In line	435	381	323.85	460	500	540	M20x2.5 no.23	Ø22 no.24	240	160	-	M16x2 no.6	799	125	224.5	-

## CUTTER DRIVES

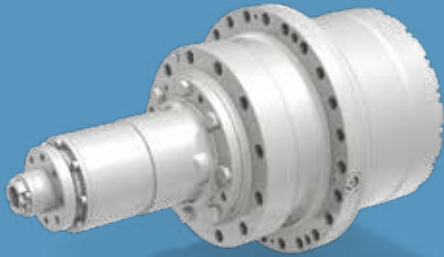

### FA Series

Dual stage planetary drive units with integrated pulley support, designed for cold planers, milling machines and surface mining machines with engine power from 80 to 1200kW and different rotor widths. The offset input option ensures higher machine productivity due to the increased cutting depth. The shiftable 2 speed solution allows two possible cutting speeds with huge benefits in terms of machine performance.



HYDRAULIC SOLUTIONS



COLD MILLING  
MACHINES

### Main options

- Two speed shifting transmission
- Main drive from proven cutter standard range (FA130/FA200)
- Hydraulic shifting unit for gear change
- Cutter main drive & shifting unit modular concept for easy maintenance

### Key features

- Compact structure
- High performance
- Notchless ground tooth root
- Different ratios
- Integrated disc-brake
- High availability by highest teeth and production quality
- Suitable for various hydraulic motors

### Torque (kNm)

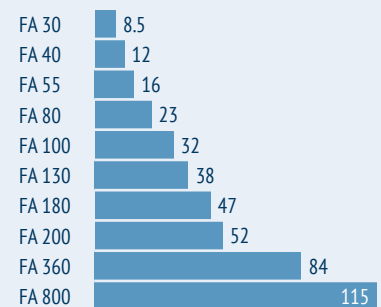



Type	Ratios	Max Cutting Torque	Max Input Power	Bearings Load Ratings		Version (1)
	1:	kNm	kW	C dyn. (kN)	C0 stat. (kN)	
FA 30	19-22	8.5	80	132/194	255/325	ST
FA 40	19	12	110	224	405	ST
FA 40	19	12	110	224	405	MI
FA 55	16-19-22	16	150	224	405	ST
FA 55	16-19-22	16	150	224	405	MI
FA 80	19	23	220	300	570	ST
FA 100	14-21-22-26	32	300	498	1,010	ST
FA 100	14-21-22-26	32	300	498	1,010	MI
FA 130	14-18-21-22-26	38	400	750	1,290	ST
FA 130	14-18-21-22-26	38	400	750	1,290	MI
FA 200	20-24	47	500	787	1,650	ST
FA 200	20-24	47	500	787	1,650	MI
FA 360	25	84	880	1,040	2,450	ST
FA 800	24	115	1,200	4,300	9,650	ST

(1) ST = Standard Input / MI = Mechanical Input (Hydraulic Motor)

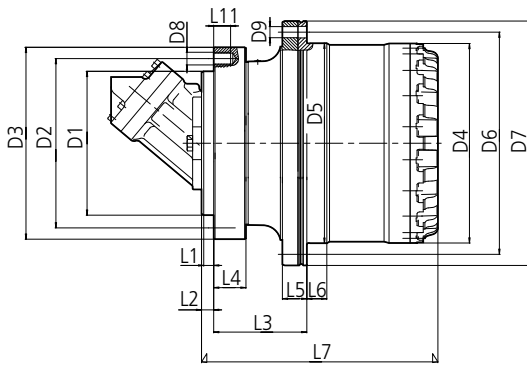

Standard input version - ST

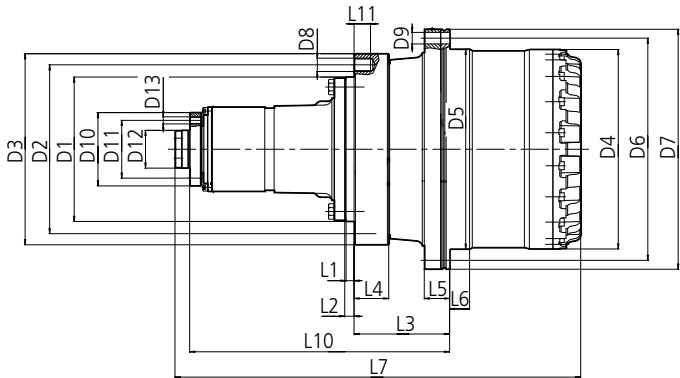

Mechanical input version - MI

Type	L1	L2	L3	L4	L5	L6	L7	L10	L11	R1	R2	D1	D2	D3	D4	D5	D6	D7	D8	D9	Qty. D8/D9	D10	D11	D12	D13	Qty. D13
FA 30	13	25	75	15	29	25	278.5	-	15	2.5	2.5	-	-	-	269	270	305	335	M16x2	17.5	18/18	-	-	-	-	-
FA 40	12	35	91	21	34	26	327	-	21	2.5	2.5	270	310	345	294	295	335	370	M20x1.5	17.5	16/20	-	-	-	-	-
FA 40	10	10	125	55	32	26	631.5	402	55	1	2.5	270	310	360	294	295	335	370	M20x1.5	17.5	16/20	138	110	80	M16x2	6
FA 55	12	25	110	24	34	30	374	-	24	1	2.5	280	325	360	329	350	400	435	M20x1.5	22	24/20	-	-	-	-	-
FA 55	18	18	136	50	34	30	688.5	421	50	1	2.5	280	325	360	329	350	400	435	M20x1.5	22	24/20	138	110	80	M16x2	6
FA 80	20	35	90	22	35	24	414.5	-	22	4	2.5	330	370	410	374	400	450	490	M24x2	25	20/20	-	-	-	-	-
FA 100	35	35	165	28	51	43	461	-	28	12/60	5	390	460	500	407	408	460	502	M24x2	26	30/24	-	-	-	-	-
FA 100	8	8	182	28	40	43	843.5	540	28	1.6	2.5	325	380	415	407	408	460	502	M20x2.5	26	12/12	165	130	85	M16x2	8
FA 130	18	20	215	78	57	45	530	-	37	2	2	325	380	430	449	450	500	540	M30x2.5	26	12/24	-	-	-	-	-
FA 130	18	20	215	78	57	45	913	585	37	2	2	325	380	430	449	450	500	540	M30x3.5	26	12/24	165	130	85 k6	M16x2	8
FA 200	20	25	160	102	58	22	603.5	-	37	2	2	323.8	381	482	540	605	635	663	M30x2	18	12/24	-	-	-	-	-
FA 200	20	25	160	102	58	22	890.5	438	37	2	2	323.8	381	482	540	605	635	663	M30x2	18	12/24	165	130	85 k6	M16x2	8
FA 360	35	100	130	40	60	80.5	657.5	-	40	18°/100/16	10	580	680	735	649.5	650	720	775	M30x3.5	M30x3.5	30/30	-	-	-	-	-
FA 800	20	25	229	60	95	89	981	-	60	6	8	830	980	1050	930	1040	1250	1329	M30x2	M30x2	48/48	-	-	-	-	-



## WHEEL DRIVES



### 600 Series

The Bonfiglioli 600 Series is the best solution when designing wheeled off-road machinery. With a compact design, high torque and load capacities, a negative multi-disk parking brake and an optional disengagement device to tow the vehicle in an emergency, these solutions precisely match the application requirements.



HYDRAULIC SOLUTIONS



COLD MILLING MACHINES



PAVERS



ROAD RECLAIMERS / SOIL STABILIZER



SOIL COMPACTORS

### Input speed

- up to 4,000 rpm

### Brake options

- Hydraulically released parking brake on request

### Applicable motors

- Cartridge axial piston hydraulic motors
- Flanged axial piston hydraulic motors
- Hydraulic orbit motors
- DC electric motor brake

### Main options

- Dynamic & service brake

### Key benefits

- Rotating housing flange with studs to fit wheels and drums
- Rugged design
- High torque capacity
- High load capacity
- Mechanical lifetime seals
- Compact design
- Optional mechanical gear disengagement on request

### Torque (Nm)

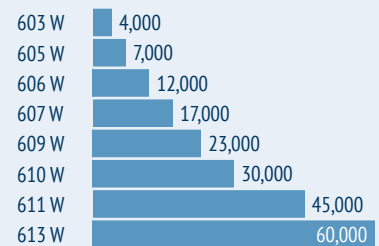

Type	Approx. Weight of Machine	Output Torque	Ratios	Motor Type
	tons	Nm	1:	
603 W	2.5 ÷ 5	4,000	19 ÷ 40.5	High speed
605 W	5 ÷ 7	7,000	22 ÷ 53	
606 W	7 ÷ 9	12,000	19 ÷ 44	
607 W	9 ÷ 16	17,000	55 ÷ 154	
609 W	16 ÷ 20	23,000	55 ÷ 147	
610 W	22 ÷ 36	30,000	55 ÷ 166	
611 W	22 ÷ 36	45,000	71 ÷ 163	
613 W	22 ÷ 36	60,000	56 ÷ 147	

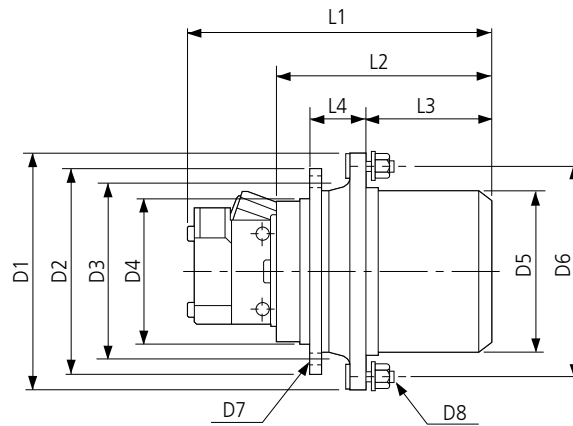

Type	D1	D2	D3	D4	D5	D6	D7	D8	L1	L2	L3	L4
603 W	280	270	230	190	200	245	M16x2 no.8	M18x1.5 no.6	Based on the motor type	230	128	72
					160	205					25	175
605 W	310	270	230	190	220	275	M16x2 no.8	M20x1.5 no.6		260	158	72
606 W	370	330	300	270	280	335	M16x2 no.18	M22x1.5 no.10		330	200	115
607 W	400	317	285	240	300	355	M20x2.5 no.20	M18x1.5 no.20		335	233	82
609 W	435	375	340	300	350	400	M20x2.5 no.16	M22x1.5 no.16		350	243	91
610 W	435	375	340	300	350	400	M20x2.5 no.16	M22x1.5 no.16		350	243	91
611 W	490	425	325	290	410	455	M20x2.5 no.24	M20x1.5 no.24		375	242	110
613 W	490	425	325	280	410	455	M20x2.5 no.24	3/4-16 UNF no.24	405	275	110	

## WHEEL DRIVES



### 600 Series

When designing an all-wheel drive grader, the integration of the 600 series, developed for this high speed application, is the best possible choice for your vehicle. The solution includes a high-speed clutch device.



HYDRAULIC SOLUTIONS



AWD  
GRADERS

### Torque (Nm)

606 W2 15,000





Type	Approx. Weight of Machine	Output Torque	Ratios	Motor Type
	tons	Nm	1:	
606 W2	14 ÷ 26	15,000	30	high speed

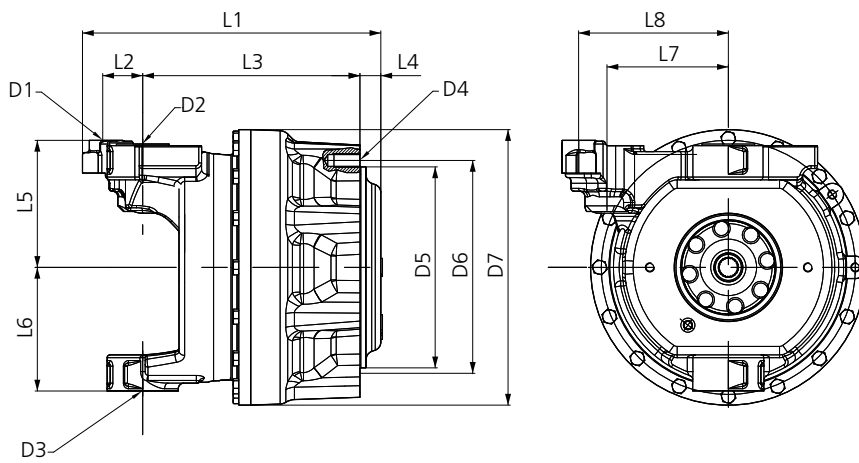

Type	D1	D2	D3	D4	D5	D6	D7	L1	L2	L3	L4	L5	L5	L5	L6
606 W2	30	50	50	M24x3 no.8	356	410	490	528	60	385	37	225	219	215	265

## WHEEL DRIVES



### 600W2/3 Series

This gear shift final drive is specifically designed for wheeled machines featuring a significantly different travel/operating speed ratio.

This product is the ideal solution for road paving machines, construction equipment and agricultural/forestry machines.



HYDRAULIC SOLUTIONS



WHEELED  
PAVERS

#### Applicable motors

- Cartridge axial piston hydraulic motors

#### Brake

- Hydraulically released multidisc type
- Parking braking
- Emergency braking

#### Key features

- Dual gear ratio, hydraulic Lo-Hi speed shifting
- Rotating housing
- Rugged design
- High torque capacity
- High load capacity
- Mechanical lifetime seals
- Compact design
- Hydraulically operated multidisc clutches, allowing both speed shifting and brake

#### Torque (Nm)

606W2/3	15,000
610W2/3	40,000
611W2/3	50,000



Type	Approx. Weight of Machine tons	Output Torque Nm	Ratios 1:	Motor Type
606W2/3	up to 14	15,000	20 - 24 Hi speed 70 - 114 Lo speed	Axial piston, variable displacement
610W2/3	18 ÷ 28	40,000	20.5 - 24.5 Hi speed 71 - 141 Lo speed	
611W2/3	28 ÷ 36	55,000	35 Hi speed 234 Lo speed	

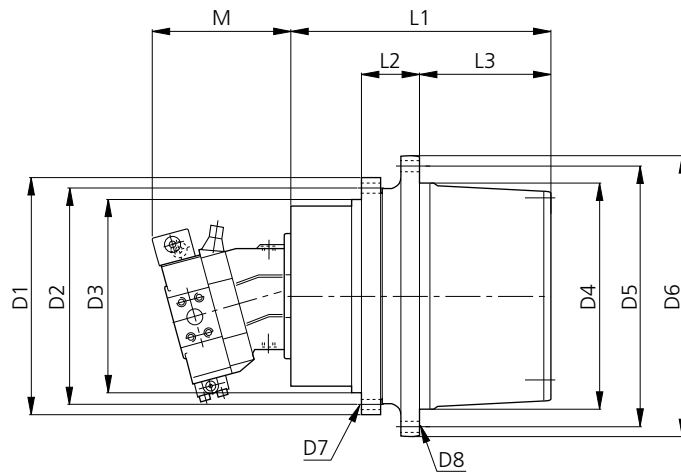

Type	D1	D2	D3	D4	D5	D6	D7	D8	L1	L2	L3
606W2/3	430	360	300	290	335	370	M16x2 no.16	M22x1.5 no.10	305	188	135
610W2/3	375	340	300	350	400	435	M20x2.5 no.16	M20x2.5 no.16	388	91	203
611W2/3	570	525	465	410	455	488	Ø22 no.12	M22x1.5 no.20	366	113	219

## WHEEL DRIVES

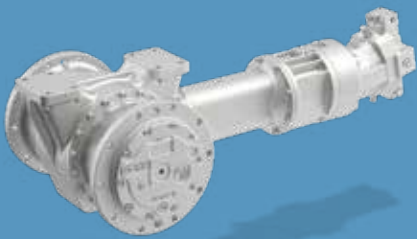

### 600 Y3 Series

When designing a latest-generation pneumatic tyred roller machine, integration of the unique 600 Y3 drive is the right choice for your vehicle. Flexible design simplifies installation on the machine frame.



HYDRAULIC SOLUTIONS



PNEUMATIC  
TYRED ROLLERS

#### Input speed

- up to 4,000 rpm

#### Brake options

Brake designed for

- Parking
- Emergency stops
- Dynamic braking at low speed (inching)

#### Applicable motors

- Cartridge axial piston hydraulic motors
- Flanged axial piston hydraulic motors

#### Torque (Nm)

605 Y3	14,000
606 Y3	22,000





Type	Approx. Weight of Machine	Output Torque	Ratios	Motor Type
	tons	Nm	1:	
605 Y3	12 ÷ 18	14,000	30	Axial piston, variable displacement
606 Y3	18 ÷ 28	22,000	32	

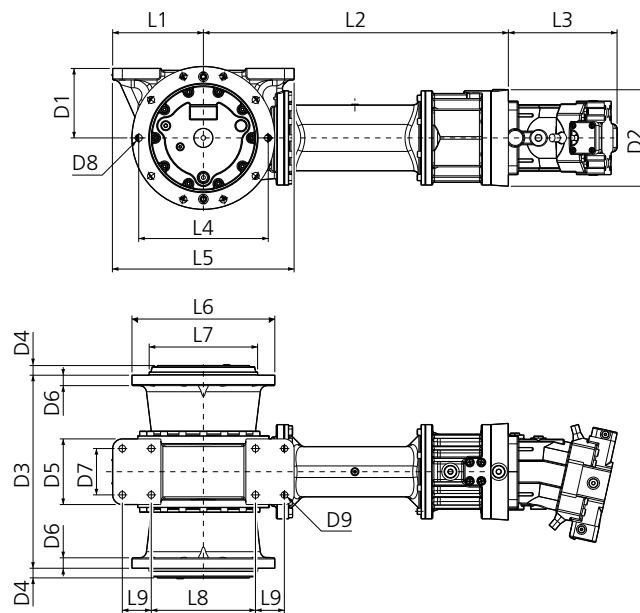

Type	D1	D2	D3	D4	D5	D6	D7	D8	D9	L1	L2	L3	L4	L5	L6	L7	L8	L9
605 Y3	200	250	500	44	170	27	130	M20x1.5 no.10	M20x2.5 no.8	230	830	Based on the motor type	335	460	370	280.8	260	75
606 Y3	180	250	500	25	170	27	120	M20x1.5 no.10	M20x2.5 no.8	236	790		335	471	370	280.8	270	75

# OUR GLOBAL PRESENCE

---

Thanks to an international network of closely interconnected commercial and production sites, we can guarantee the same high standards of Bonfiglioli quality anywhere at any given time. We know that our direct presence in local markets is the key to long-lasting success, so our family includes 18 production sites, 23 commercial sites and more than 550 distributors around the world.

Our organization is always close by, offering complete and efficient solutions and supporting our customers with dedicated services, co-engineering and after-sales assistance.



**18**

PRODUCTION SITES



**23**

COMMERCIAL SITES



**80**

COUNTRIES



**550**

DISTRIBUTORS



**~4,700**

PEOPLE

## AUSTRALIA

### Bonfiglioli Transmission (Aust.) Pty Ltd

2, Cox Place Glendenning NSW 2761  
Locked Bag 1000 Plumpton NSW 2761  
Tel. +61 2 8811 8000



## BRAZIL

### Bonfiglioli Redutores do Brasil Ltda

Av. Osvaldo Fregonezi, 171, cjs 31 e 44  
CEP 09851-015 - São Bernardo do Campo  
São Paulo  
Tel. +55 11 4344 2322



## CHINA

### Bonfiglioli Drives (Shanghai) Co. Ltd.

#68, Hui-Lian Road, QingPu District,  
201707 Shanghai  
Tel. +86 21 6700 2000



### Industry & Automation Solutions

#568, Longpan Road, Jiading District,  
201707 Shanghai



### Bonfiglioli Trading (Shanghai) Co. Ltd.

Room 423, 4<sup>th</sup> Floor, #38, Yinglun Road,  
China (Shanghai) Pilot Free Trade Zone,  
Shanghai



### Selcom Electronics (Shanghai) Co., Ltd

A7, No.5399, Waiqingsong Road, QingPu  
District,  
201707 Shanghai  
Tel. +86 21 6010 8100



A24, No.5399, Waiqingsong Road, QingPu  
District,  
201707 Shanghai

Tel. +86 21 6010 8100



## FRANCE

### Bonfiglioli Transmission S.A.S.

14 Rue Eugène Pottier  
Zone Industrielle de Moimont II  
95670 Marly la Ville  
Tel. +33 1 34474510



## GERMANY

### Bonfiglioli Deutschland GmbH

Sperberweg 12 - 41468 Neuss  
Tel. +49 0 2131 2988 0



### Bonfiglioli Vectron GmbH

Europark Fichtenhain B6 - 47807 Krefeld  
Tel. +49 0 2151 8396 0



### O&K Antriebstechnik GmbH

Ruhrallee 8-12 - 45525 Hattingen  
Tel. +49 0 2324 2050 1



## INDIA

### Bonfiglioli Transmission Pvt. Ltd.

#### Mobility & Wind Industries

AC 7 - 11, SIDCO Industrial Estate,  
Thirumudivakkam  
Kancheepuram - 600132 - Tamil Nadu  
Tel. +91 844 844 8649



#### Industry & Automation Solutions

Survey No. 528/1, Perambakkam High Road  
Mannur Village, Sriperumbudur Taluk  
Kancheepuram - 602 105 - Tamil Nadu  
Tel. +91 844 844 8649



#### Industry & Automation Solutions

Plot No E-5/2, Badhalwadi  
Talegaon MIDC Phase II,  
Pune - 410 507 - Maharashtra  
Tel. +91 844 844 8649



### Bonfiglioli Drive Systems Pvt. Ltd.

#### Industry & Automation Solutions

No 50, Pappambakkam Road,  
Mannur Village, Sriperumbudur Taluk,  
Kancheepuram - 602105 - Tamil Nadu  
Tel. +91 844 844 8649



## ITALY

### Bonfiglioli Riduttori S.p.A.

#### Industry & Automation Solutions

Via Cav. Clementino Bonfiglioli, 1  
40012 Calderara di Reno  
Tel. +39 051 6473111



#### Industry & Automation Solutions

Via Sandro Pertini, lotto 7b  
20080 Carpiano  
Tel. +39 02985081



#### Industry & Automation Solutions

Via Saliceto, 15 - 40010 Bentivoglio



#### Mobility & Wind Industries

Via Enrico Mattei, 12 Z.I. Villa Selva  
47122 Forlì  
Tel. +39 0543 789111



#### Industry & Automation Solutions

Via Unione, 49 - 38068 Rovereto  
Tel. +39 0464 443435/36



### Selcom Group S.p.A.

Via Achille Grandi, 5  
40013 Castel Maggiore (BO)  
Tel. +39 051 6387111



Via Marino Serenari, 18  
40013 Castel Maggiore (BO)  
Tel. +39 051 6387111



Via Cadriano, 19  
40057 Cadriano (BO)  
Tel. +39 051 6387111

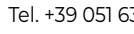

## NEW ZEALAND

### Bonfiglioli Transmission (Aust.) Pty Ltd

88 Hastie Avenue, Mangere Bridge,  
2022 Auckland  
PO Box 11795, Ellerslie  
Tel. +64 09 634 6441



## SINGAPORE

### Bonfiglioli South East Asia Pte Ltd

8 Boon Lay Way, #04-09,  
8@Tadehub 21, Singapore 609964  
Tel. +65 6268 9869



## SLOVAKIA

### Bonfiglioli Slovakia s.r.o.

Robotnícka 2129  
Považská Bystrica, 01701 Slovakia  
Tel. +421 42 430 75 64



## SOUTH AFRICA

### Bonfiglioli South Africa Pty Ltd.

55 Galaxy Avenue, Linbro Business Park,  
Sandton, Johannesburg  
2090 South Africa  
Tel. +27 11 608 2030



## SPAIN

### Tecnotrans Bonfiglioli S.A

Avinguda del Ferrocarril, n° 14,  
Polígono Industrial Can Estapé  
08755 Castellbisbal - Barcelona  
Tel. +34 93 447 84 00



## TURKEY

### Bonfiglioli Turkey Jsc

Atatürk Organize Sanayi Bölgesi,  
10007 Sk. No. 30  
Atatürk Organize Sanayi Bölgesi,  
35620 Çiğli - Izmir  
Tel. +90 0 232 328 22 77



## UNITED KINGDOM

### Bonfiglioli UK Ltd.

Unit 1 Calver Quay, Calver Road, Winwick  
Warrington, Cheshire - WA2 8UD  
Tel. +44 1925 852667



## USA

### Bonfiglioli USA Inc.

3541 Hargrave Drive  
Hebron, Kentucky 41048  
Tel. +1 859 334 3333



## VIETNAM

### Bonfiglioli Vietnam Ltd.

Lot C-9D-CN My Phuoc Industrial Park 3  
Ben Cat - Binh Duong Province  
Tel. +84 650 3577411





We have a relentless commitment to excellence, innovation & sustainability. Our team creates, distributes and services world-class power transmission & drive solutions to keep the world in motion.

#### HEADQUARTERS

##### Bonfiglioli S.p.A

Via Cav. Clementino Bonfiglioli, 1  
40012 Calderara di Reno - Bologna (Italy)  
Tel. +39 051 6473111

