

BONFIGLIOLI

SERIE VF-W

Reductores de tornillo sinfín universal

 **Bonfiglioli**



Párrafo	Descripción	Página	Párrafo	Descripción	Página
INFORMACIÓN GENERAL			VF-EP / W-EP - REDUCTORES Y MOTORREDUCTOR PARA AMBIENTES CORROSIVOS Y ASÉPTICOS		
		2			187
1	Símbolos y unidades de medida	2	33	Principales beneficios de la serie EP para la industria de la alimentación	187
2	Definiciones	3	34	Designación	190
3	Temperaturas límites admitidas	6	35	Opciones del reductor	192
4	Selección	7	36	Opciones de los motores	192
5	Verificación	9	37	Otras informaciones sobre reductores y motorreductores	193
6	Instalacion	9	38	Accesorios para la serie EP	193
7	Lubricación	11			
8	Almacenaje	12			
9	Condiciones de suministro	12			
REDUCTORES DE TORNILLO SIN FÍN			DISPOSITIVO FIN DE CARRERA RVS		
		13			195
10	Características constructivas	13	39	Informaciones generales	195
11	Formas constructivas	14	40	Codigos para pedidos	196
12	Ejecuciones de montaje	15	41	Designación	197
13	Designación	18	42	Tabla de selección motorreductor	198
14	Opciones de los reductores	20	43	Dimensiones	201
15	Posicion de montaje y orientación de la caja de bornes	26	44	Opciones	205
16	Cargas radiales	35			
17	Cargas axiales	36	MOTORES ELÉCTRICOS		
18	Rendimiento	39			206
19	Irreversibilidad	39	M1	Símbolos y unidades de medida	206
20	Juegos angulares	41	M2	Características generales	207
21	Tablas de selección de los motorreductores	42	M3	Características mecánicas	210
22	Tablas de datos técnicos de reductores	73	M4	Características eléctricas	214
23	Combinaciones de las relaciones de reducción de los reductores combinados serie VF/VF, VF/W, W/VF	95	M5	Motores freno asíncronos	221
24	Predisposiciones motor	96	M6	Motores freno en c.c., tipo BN_FD y M_FD	222
25	Momento de inercia	99	M7	Motores freno de c.a., tipo BN y M_FA	226
26	Dimensiones motorreductores y reductores predispuestos para motor IEC	111	M8	Sistema de desbloqueo del freno	229
27	Dimensiones reductores con eje de entrada HS	177	M9	Opciones	231
28	Dimensiones reductor con brazo de reacción	181	M10	Datos técnicos de los motores	244
29	Dimensiones para reductores con tapón de protección	181	M11	Dimensiones motores	261
30	Accesorios	182			
31	Eje del cliente	183			
32	Limitador de par	184			

Revisiones

El índice de revisión del catálogo está indicado en la Pág. 270. En la dirección www.bonfiglioli.com se encuentran disponibles los catálogos con las revisiones actualizadas.



INFORMACIÓN GENERAL

1 SÍMBOLOS Y UNIDADES DE MEDIDA

Símbolos	Unidades de medida	Descripción	Símbolos	Unidades de medida	Descripción
$A_{N 1,2}$	[N]	Carga axial nominal	$n_{1,2}$	[min ⁻¹]	Velocidad
f_s	–	Factor de servicio	$P_{1,2}$	[kW]	Potencia
f_T	–	Factor térmico	$P_{N 1,2}$	[kW]	Potencia nominal
f_{TP}	–	Factor de temperatura	$P_{R 1,2}$	[kW]	Potencia absorbida
i	–	Relación de reducción	$R_{C 1,2}$	[N]	Carga radial de cálculo
I	–	Relación de intermitencia	$R_{N 1,2}$	[N]	Carga radial nominal
J_C	[Kgm ²]	Momento de inercia de la carga	S	–	Factor de seguridad
J_M	[Kgm ²]	Momento de inercia del motor	t_a	[°C]	Temperatura ambiente
J_R	[Kgm ²]	Momento de inercia del reductor	t_s	[°C]	Temperatura superficial
K	–	Factor de aceleración de las masas	t_o	[°C]	Temperatura del aceite
K_r	–	Constante de transmisión	t_f	[min]	Tiempo de funcionamiento con carga constante
$M_{1,2}$	[Nm]	Par	t_r	[min]	Tiempo de reposo
$M_{c 1,2}$	[Nm]	Par de cálculo	η_d	–	Rendimiento dinámico
$M_{n 1,2}$	[Nm]	Par nominal	η_s	–	Rendimiento estático
$M_{r 1,2}$	[Nm]	Par resistente			

¹ valor correspondiente al eje de entrada

² valor correspondiente al eje de salida



Este símbolo indica informaciones técnicas de particular importancia que no se han de desatender



Este símbolo indica la referencia angular para indicar la dirección de la carga radial (eje visto de frente).



Este símbolo indica situaciones de peligro que, de ignorarse, pueden resultar en riesgos para la salud personal y la seguridad.



Símbolo referido al peso del reductor o del motorreductor. El valor indicado en la tabla de los motorreductores, comprende el peso del motor de 4 polos el peso del lubricante contenido, en el caso que esté previsto por BONFIGLIOLI RIDUTTORI.



Este símbolo indica la página en la que se encuentra la información.

2 DEFINICIONES

2.1 PAR

Par nominal M_{n2} [Nm]

Es el par transmisible en la salida con carga uniforme continua, referido a la velocidad de entrada n_1 y a la correspondiente velocidad de salida n_2 .

Se calcula sobre la base de un factor de servicio $f_s = 1$.

Par resistente M_{r2} [Nm]

Representa el par solicitado por la aplicación y deberá ser siempre igual o menor que el par de salida nominal M_{n2} del reductor seleccionado.

Par de cálculo M_{c2} [Nm]

Es el valor del par que se utiliza para la selección del reductor, en relación con el par solicitado M_{r2} y el factor de servicio f_s y se obtiene con la fórmula:

$$M_{c2} = M_{r2} \times f_s \leq M_{n2} \quad (1)$$

2.2 POTENCIA

Potencia nominal a la entrada P_{n1} [kW]

Parámetro que figura en la tabla de datos técnicos nominales y representa la potencia aplicable al reductor en función de la velocidad n_1 y con un factor de servicio $f_s = 1$.



2.3 RENDIMIENTO

Rendimiento dinámico [η_d]

Se define como la relación entre la potencia de salida P_2 y la de entrada P_1 :

$$\eta_d = \frac{P_2}{P_1} \quad (2)$$

Particularmente es oportuno recordar que los datos del par M_{n2} que figuran en el catálogo han estado calculados en función del rendimiento dinámico η_d , obtenido después del periodo de rodaje de los reductores. Después del periodo de rodaje, la temperatura de funcionamiento disminuye hasta alcanzar su estabilización. La temperatura de funcionamiento en carga, está influenciada por el tipo de servicio y por la temperatura ambiente, consultar el capítulo "Temperaturas límite admitidas" para información sobre los valores límite. Si, por cualquier motivo, se espera que la temperatura de funcionamiento alcance los valores límite es necesario equipar el reductor con retenes de fluoro-elastómero especificando en el pedido la opción PV.

Rendimiento estático [η_s]

Es el rendimiento del reductor en el momento del arranque, para los reductores de engranajes. Éste no es significativo, pero debe tenerse en particular consideración en la selección de la motorización con reductores de tornillo sinfín destinados en aplicaciones caracterizadas por un tipo de servicio intermitente (ejem. Elevación).

2.4 RELACIÓN DE REDUCCIÓN [i]

Es el valor de la relación de reducción entre las velocidades, se identifica por el símbolo [i], y se calcula a partir de la velocidad de entrada n_1 y de la velocidad de salida n_2 mediante la siguiente expresión:

$$i = \frac{n_1}{n_2} \quad (3)$$

2.5 MOMENTO DE INERCIA J_r [kgm^2]

Los momentos de inercia contenidos en el catálogo están referidos al eje de entrada del reductor y, por lo tanto, cuando se acopla a un motor eléctrico, su valor simplemente debe sumarse al del motor.



2.6 FACTOR DE SERVICIO [f_s]

El factor de servicio es el parámetro que traduce a un valor numérico la dificultad del servicio a que el reductor estará solicitado, teniendo en cuenta, con la inevitable aproximación, el funcionamiento diario, variaciones de carga y las posibles sobrecargas vinculadas con la aplicación específica del reductor.

En el gráfico siguiente, el factor de servicio expuesto se obtiene, después de haber seleccionado la columna correspondiente a las horas de funcionamiento diario, por la intersección entre el número de arranques / hora y una de las curvas K1, K2 y K3. Las curvas K_ están asociadas a la naturaleza del servicio (aproximadamente: uniforme, medio y pesado) mediante el factor de aceleración de las masas K, ligado a la relación entre las inercias de las masas conducidas y el motor. Independientemente del valor del factor de servicio así obtenido, destacamos que existen aplicaciones, entre las cuales, y solamente a título de ejemplo, la elevación, para las que la rotura de un elemento del reductor puede representar un riesgo de lesiones al personal que opere en las proximidades.

En caso de dudas de aplicación, concernientes a los posibles riesgos, aconsejamos consultar previamente con nuestro Servicio Técnico.

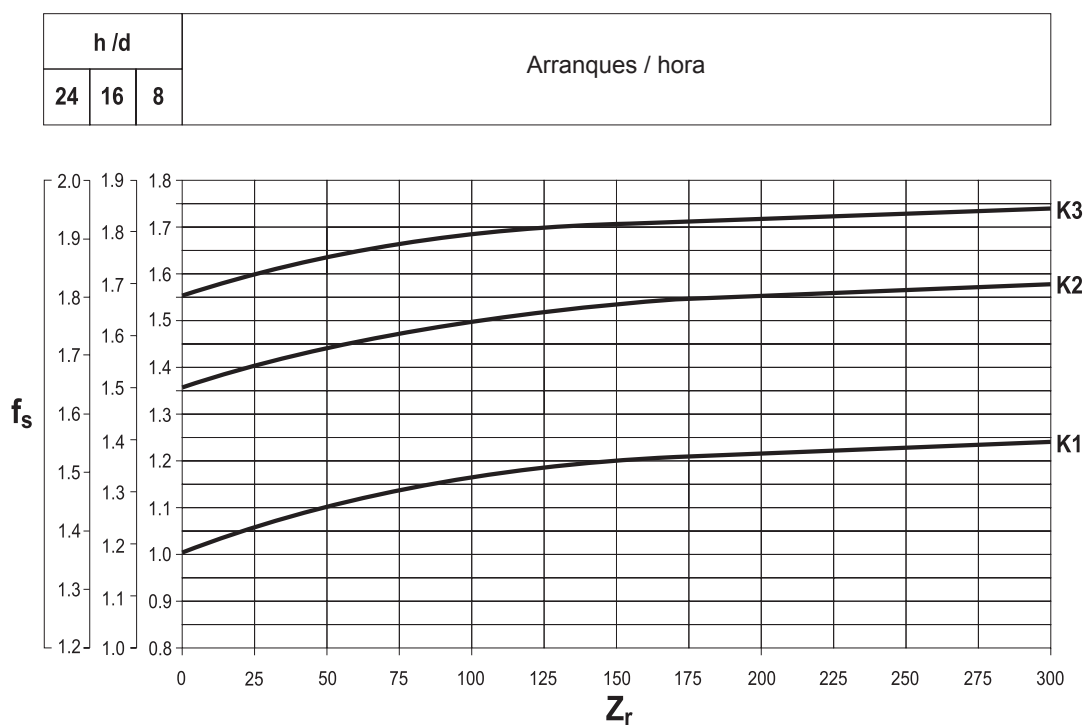

Factor de aceleración de las masas, [K]

Este parámetro sirve para seleccionar la curva correspondiente a un determinado tipo de carga. El valor viene dado por la relación:

$$K = \frac{J_c}{J_m} \quad (4)$$

$K = \frac{J_c}{J_m}$	→	$J_c =$ Momento de inercia de las masas conducidas, referido al eje del motor
		$J_m =$ Momento de inercia del motor

$K \leq 0,25$	→	K1	Carga uniforme
$0,25 < K \leq 3$	→	K2	Carga con choques moderados
$3 < K \leq 10$	→	K3	Carga con choques fuertes
$K > 10$	→		Consultar con nuestro Servicio Técnico.



3 TEMPERATURAS LÍMITES ADMITIDAS

Símbolo	Descripción / Condición	Valor (*)	
		Aceite sintético	Aceite mineral
t_a	Temperatura ambiente		
$t_{au \text{ min}}$	Mínima temperatura ambiente de operación	-30°C	-10°C
$t_{au \text{ Max}}$	Máxima temperatura ambiente de operación	+50°C	+40°C
$t_{as \text{ min}}$	Mínima temperatura ambiente de almacenaje	-40°C	-10°C
$t_{as \text{ Max}}$	Máxima temperatura ambiente de almacenaje	+50°C	+50°C
t_s	Temperatura superficial		
$t_{s \text{ min}}$	Mínima temperatura superficial para arranque con carga parcial (#)	-25°C	-10°C
$t_{sc \text{ min}}$	Mínima temperatura superficial para arranque a plena carga	-10°C	-5°C
$t_{s \text{ Max}}$	Máxima temperatura superficial en trabajo continuo en régimen (medición realizada cerca de la entrada del reductor)	+100°C	+100°C (@)
t_o	Temperatura del aceite		
$t_{o \text{ Max}}$	Máxima temperatura del aceite en trabajo continuo	+95°C	+95°C (@)

(*) = Para los valores mínimos y máximos específicos para las diferentes viscosidades del aceite, así como para el uso en circuitos hidráulico, consultar la tabla "Selección de la viscosidad óptima del aceite". Para valores de temperatura de $t_a < -20^\circ\text{C}$ y $t_s, t_o > 80^\circ\text{C}$, seleccionar (tal y como se permite en fase de configuración del producto) el tipo de juntas fabricados en el material más idóneo para el tipo de aplicación. Si es necesario contactar con el Servicio Técnico Bonfiglioli.

(@) = Para valores de t_s y $t_o > 80^\circ\text{C}$ y $< 95^\circ\text{C}$, se desaconseja la utilización en servicio continuo.

(#) = Para el arranque a plena carga se aconseja el uso de una rampa gradual y prever un mayor consumo del motor. Si es necesario contactar con el Servicio Técnico Bonfiglioli.



4 SELECCIÓN

4.1 Selección de un motorreductor

- Determinar el factor de servicio f_s como se ha descrito anteriormente.
- Calcular la potencia requerida en el eje de entrada del reductor.

$$P_{r1} = \frac{M_{r2} \times n_2}{9550 \times \eta_d} \quad [\text{kW}] \quad (5)$$

- En el capítulo: “Datos técnicos de los motorreductores” seleccionar de la tabla correspondiente, una potencia normalizada P_n tal que cumpla:

$$P_n \geq P_{r1} \quad (6)$$

Si no se indica de forma distinta, la potencia P_n indicada en el catálogo está referida al servicio continuo S1. Para motores utilizados en condiciones distintas de S1, será necesario identificar el tipo de servicio previsto en las Normas CEI 2-3/IEC 34-1.

Particularmente, para servicios de S2 a S8 y para tamaño de motor igual o inferior a 132, es posible obtener un incremento sobre la potencia prevista para el servicio continuo, debiendo satisfacer la condición:

$$P_n \geq \frac{P_{r1}}{f_m} \quad (7)$$

El factor de incremento f_m se obtiene de la tabla siguiente.

Relación de intermitencia

$$I = \frac{t_f}{t_f + t_r} \times 100 \quad (8)$$

t_f = tiempo de funcionamiento con carga constante

t_r = tiempo de reposo

	SERVICIO						
	S2			S3*			S4 - S8
	Duración del ciclo [min]			Relación de intermitencia (I)			Contactar
	10	30	60	25%	40%	70%	
f_m	1.35	1.15	1.05	1.25	1.15	1.1	

* De todos modos, la duración del ciclo deberá ser igual o inferior a 10 minutos; si fuese superior, consultar al Servicio Técnico de Bonfiglioli Riduttori.



Finalmente, en la sección correspondiente a la potencia instalada P_n seleccionar el motorreductor que desarrolle la velocidad más próxima a la n_2 deseada para la cual el factor de seguridad S sea igual o superior al factor de servicio f_s .

$$S \geq f_s \quad (9)$$

El factor de seguridad queda así definido:

$$S = \frac{M_{n2}}{M_2} = \frac{P_{n1}}{P_1} \quad (10)$$

En la tabla de selección de los motorreductores, el acoplamiento está diseñado para motores de 2, 4 y 6 polos, alimentados a 50 Hz.

Para velocidades distintas de funcionamiento, la selección debe efectuarse según los datos nominales correspondientes a los reductores.

4.2 Selección de un reductor

- Determinar el factor de servicio f_s
- Determinar el par de cálculo M_{c2} , con la relación:

$$M_{c2} = M_{r2} \times f_s \quad (11)$$

- Calcular la relación de Transmisión:

$$i = \frac{n_1}{n_2} \quad (12)$$

- En el capítulo “Datos técnicos de los reductores” determinar el tamaño del reductor que, para la velocidad de funcionamiento n_1 y para la relación $[i]$ más próxima a la calculada, ofrezca un par nominal que satisfaga la siguiente Condición:

$$M_{n2} \geq M_{c2} \quad (13)$$

Verificar la compatibilidad del motor seleccionado en el parágrafo “Predisposiciones Motor”.



5 VERIFICACIÓN

Una vez realizada la selección del reductor, o motorreductor, es oportuno realizar las siguientes Verificaciones:

a) Par máximo

En general, el par máximo (entendido como pico de carga instantáneo) aplicable al reductor, no deberá superar el 150% del par nominal M_{n2} ; se permiten valores de pico de carga hasta 300%, sujetos a evaluación y aprobación por el Servicio Técnico Bonfiglioli.

Para los motores trifásicos de doble polaridad, es necesario prestar una atención especial al par de conmutación instantánea, que se genera en la conmutación de la alta velocidad a la baja, por cuanto puede ser decisivamente más elevado que el propio par máximo. Un método simple y económico de reducir este par, es el alimentar durante la conmutación, con solamente dos fases el motor (el tiempo de alimentar con dos fases, puede estar regulado con un temporizador):

Par de conmutación	
$Mg_2 = 0.5 \times Mg_3$	
Mg_2	Par de conmutación alimentando 2 fases
Mg_3	Par de conmutación alimentando 3 fases

b) Cargas radiales

Verificar que las cargas radiales que actúan sobre los ejes de entrada y/o salida, se encuentren comprendidas dentro de los valores admitidos en el catálogo. Si fuesen superiores, aumentar el tamaño del reductor o modificar el apoyo de la carga. Recordamos que todos los valores indicados en el catálogo están referidos a las cargas aplicadas en el punto medio de la parte externa del eje, por lo que en fase de verificación, es indispensable tener presente esta condición, procediendo, en caso necesario, a determinar con las fórmulas adecuadas la carga admisible a la distancia x a la que se aplica la carga.

c) Cargas axiales

También, las eventuales cargas axiales deben ser comparadas con las admisibles. En el caso de cargas axiales muy elevadas o combinadas con cargas radiales, se recomienda consultar con nuestro Servicio Técnico.

d) Arranques / hora

Para servicios distintos de S1, con un número elevado de arranques / hora, se deberá tener en cuenta un factor Z (se determina con las indicaciones expuestas en el capítulo de motores) que define el número máximo de arranques específico para la aplicación requerida.

6 INSTALACION

6.1 Especificación de carácter general

a) Asegurarse que la fijación del reductor sea suficiente rígida para evitar cualquier vibración. Sí se prevén choques, sobrecargas prolongadas o posibles bloqueos es conveniente la instalación de acoplamientos hidráulicos, embragues, limitadores de par, etc.



- b) Antes del eventual pintado, proteger las superficies mecanizadas y el labio de los retenes para evitar el contacto de la goma con el disolvente, perjudicando la integridad del propio retén.
- c) Los órganos que se hayan de calar en los ejes de salida del reductor, han de mecanizarse con tolerancia ISO H7 para evitar el acoplamiento excesivamente forzado que, en la fase de montaje, pudiera dañar irreparablemente el propio reductor. Además, para el montaje y desmontaje de estos órganos, se aconseja el uso tirantes y extractores adecuados utilizando el taladro roscado situado en el extremo de los ejes.
- d) Las superficies de contacto deberán estar limpias y tratadas, antes del montaje, con los productos protectores adecuados evitando la oxidación y el consiguiente bloqueo de las piezas.
- e) Antes de la puesta en servicio del reductor, asegurarse que la máquina que lo incorpora esté de acuerdo con las disposiciones de la Directiva Máquina 89/392 y sucesivas actualizaciones.
- f) Antes de la puesta en marcha de la máquina, cerciorarse que la posición del nivel de lubricante esté de acuerdo con la posición de montaje del reductor y que la viscosidad sea la adecuada al tipo de carga.
- g) En el caso de instalación al aire libre, es necesario aplicar protecciones adecuadas con la finalidad de evitar la exposición directa a los agentes atmosféricos y la radiación solar.

6.2 Puesta en servicio reductores serie W

Los grupos W63, W 75, y W 86 se suministran con una tapa lateral orientable, dotada de tapón ciego por exigencias del Transporte. Antes de la puesta en servicio de los aparatos este tapón debe ser sustituido por el tapón de respiración suministrado con cada unidad. Ver figura:

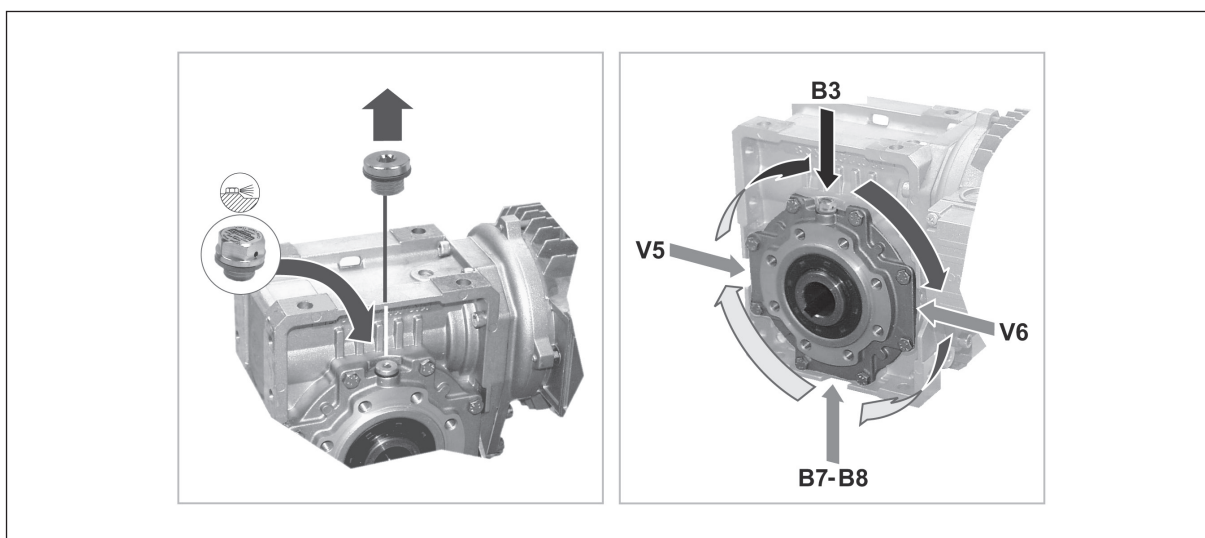

En la orientación B6, por el contrario, el tapón ciego NO debe ser sustituido por el tapón de respiración.



8 ALMACENAJE

Para un correcto almacenaje de los productos es necesario respetar las reglas siguientes:

- a) Excluir las zonas al aire libre, zonas expuestas a la intemperie o con humedad Excesiva.
- b) Evitar el contacto directo con el pavimento, interponiendo siempre bases de madera o similares.
- c) Para periodos de almacenaje y paradas prolongadas, las superficies de unión como bridas, ejes y acoplamientos, deberán protegerse con productos antioxidantes adecuados (Mobilarma 248 o equivalente). En este caso el reductor deberá situarse con el tapón de respiración en la posición más alta y lleno totalmente de aceite. Antes de su puesta en marcha, deberá restablecerse el nivel en los reductores con la cantidad correcta y el tipo de lubricante previsto.

9 CONDICIONES DE SUMINISTRO

Los reductores se suministran como sigue:

- a) preparados para su instalación en la posición de montaje especificada en el Pedido.
- b) verificados de acuerdo con las especificaciones internas;
- c) con las superficies de acoplamiento sin pintar;
- d) equipados con las tuercas y espárragos de montaje, previstos para el montaje de los Motores;
- e) equipados con protecciones de material plástico en los Ejes;
- f) provistos con cáncamos de elevación (donde esté previsto).



REDUCTORES DE TORNILLO SINFIN

10 CARACTERÍSTICAS CONSTRUCTIVAS

10.1 Las características más relevantes comunes a todos los reductores de tornillo sinfín Bonfiglioli

- Eje de salida hueco simétrico, para la fijación bilateral del reductor al eje de salida suministrado (disponible como accesorio).
- Engranajes de tornillo sinfín rectificadas, su mecanización de precisión da como resultado un rendimiento elevado y funcionamiento muy Silencioso.
- Numerosas opciones para la fijación del reductor disponiendo de las configuraciones, patas, brida o pendular (brazo de reacción opcional).
- Extensa posibilidad de personalización seleccionado la más apropiada en la lista de opciones disponibles.

10.2 Las características específicas de los grupos VF

- Caja de aluminio inyectado para VF 27, VF30, VF 44 Y VF 49. Caja de fundición gris para los grupos de VF 130 a VF 250. Estos últimos están pintados con polvo epoxi termoendurecido.

10.3 Las características específicas de los grupos W

- Caja monobloc de aluminio inyectado, rígida y precisa.
- Gran versatilidad y flexibilidad de aplicación dada su forma cúbica y las numerosas superficies mecanizadas disponibles para la fijación del reductor u órganos y accesorios.
- Configuración integral del motorreductor, particularmente compacta, ligera y Económica.
- Retén en el eje de entrada de los grupos W63, W75 y W86 montado internamente y con mezcla de fluoro-elastómero para mejorar las condiciones de funcionamiento y la duración.

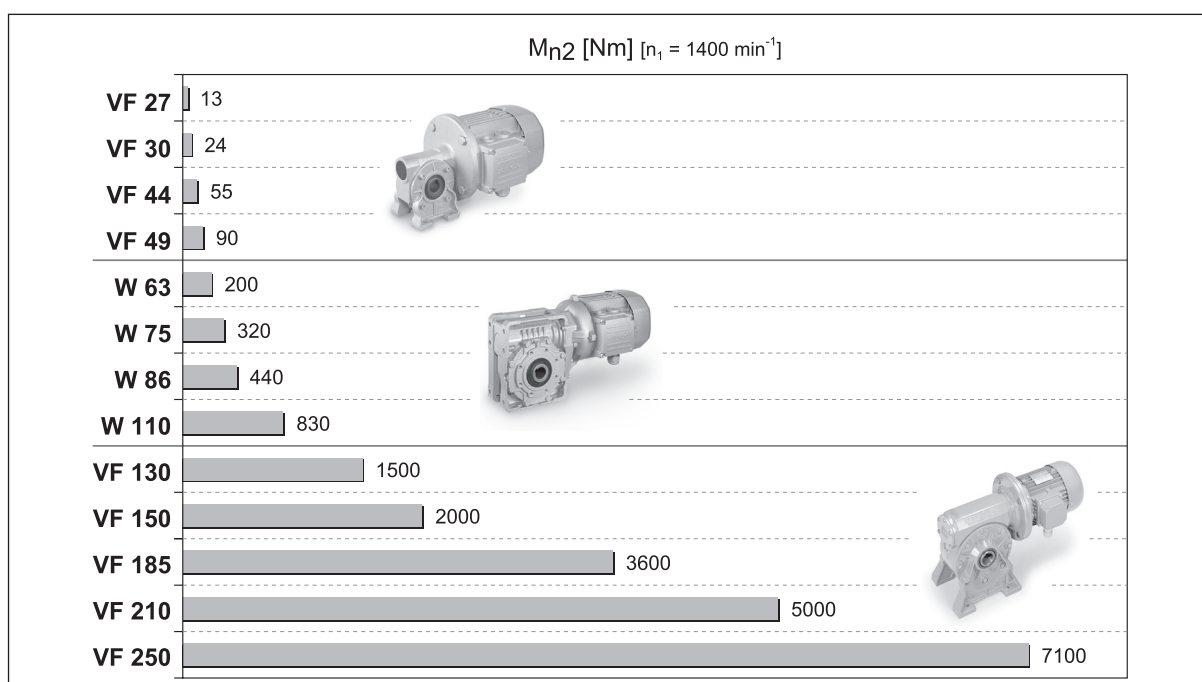



11 FORMAS CONSTRUCTIVAS

VF_		W_	
	<p>N VF 27 ... VF 250</p> <p>Patas y vis sinfín horizontal abajo</p>		<p>U W 63 ... W 110</p> <p>Montaje universal</p>
	<p>A VF 27 ... VF 250</p> <p>Patas y vis sinfín horizontal arriba</p>		
	<p>V VF 27 ... VF 250</p> <p>Patas y vis sinfín vertical</p>		
	<p>F VF 27 ... VF 185</p> <p>Brida estándar</p>		<p>UF W 63 ... W 110</p> <p>Brida de montaje estándar</p>
<p>F1 F2</p> <p>FA1 FA2</p>	<p>FA VF 44 ... VF 49</p> <p>Brida alta</p>		
	<p>FC VF 130 ... VF 185</p> <p>Brida corta</p>		
<p>FC1 FC2</p> <p>FR1 FR2</p>	<p>FR VF 130 ... VF 185</p> <p>Brida con rodamiento reforzados</p>		
	<p>P VF 30 ... VF 250</p> <p>Brida pendular</p>		<p>UFC W 63 ... W 110</p> <p>Brida con longitud reducida</p>
<p>P1 P2</p> <p>(VF 30...VF 250) (VF 130...VF 185)</p>	<p>P1 = P2 VF 30 ... VF 49</p> <p>VF 210, VF 250</p>	<p>UFC1 UFC2</p> <p>UFCR1 UFCR2</p>	
	<p>U VF 30 ... VF 49</p> <p>Patas integradas</p>		<p>UFCR W 75</p> <p>Brida con longitud y diámetro reducidos</p>

Para los reductores combinados tipo VF/VF, VF/W y W/VF la forma constructiva se refiere al segundo reductor (lado máquina)



12 EJECUCIONES DE MONTAJE

Para los reductores combinados, si no se especifica lo contrario en el pedido, se suministrarán en la ejecución de montaje resaltada en color gris en el siguiente esquema.

	CW1	CCW1	CW2	CCW2	CW3	CCW3	CW4	CCW4
U								
UF_ UFC_ UFR1_								
N								
A								
V								
F1 FA1 FC1 FR1								
F2 FA2 FC2 FR2								
P1								
P2								

Tapa para fijación pendular



La configuración HS (eje de entrada cilíndrico), puede suministrarse en todas las ejecuciones de montaje representadas.

En la configuración P (IEC) determinadas ejecuciones de montaje solamente pueden obtenerse utilizando bridas IEC (B5 o B14) de tamaño igual o inferior a la indicada en la tabla siguiente.

		CW1 CCW1	CW2 CCW2	CW3	CCW3	CW4 CCW4
VF/VF30/44	A, N, V, P1 F-FA,U	63B14	63B14	63B14	63B14	63B14
VF/VF30/49	A, N, V, P1, F-FA,U	63B14	63B14	63B14	63B14	63B14
VF/W30/63	U, UF-UFC	63B5-63B14	63B5-63B14	63B5-63B14	63B5-63B14	63B5-63B14
VF/W44/75	U, UF-UFC-UFCR	71B5-71B14	71B5-71B14	71B5-71B14	71B5-71B14	71B5-71B14
VF/W44/86	U, UF-UFC	71B5-71B14	71B5-71B14	71B5-71B14	71B5-71B14	71B5-71B14
VF/W49/110	U, UF-UFC	80B5-80B14	80B5-80B14	80B5-80B14	80B5-80B14	80B5-80B14
W/VF63/130	N	71B5-90B14	90B5-90B14	71B5-90B14	71B5-90B14	71B5-90B14
	A	90B5-90B14	71B5-90B14	90B5-90B14	90B5-90B14	90B5-90B14
	V		90B5-90B14			—
	F1	90B5-90B14	71B5-90B14	90B5-90B14	71B5-90B14	90B5-90B14
	FC1-FR1				90B5-90B14	
	P1				90B5-90B14	
	F2	90B5-90B14	71B5-90B14	71B5-90B14	90B5-90B14	90B5-90B14
	FC2-FR2			90B5-90B14		
P2			90B5-90B14			
W/VF86/150	N	112B5-112B14	112B5-112B14	71B5-112B14	71B5-112B14	71B5-112B14
	A	112B5-112B14	90B5-112B14	112B5-112B14	112B5-112B14	112B5-112B14
	V	112B5-90B14	112B5-90B14			71B5-112B14
	F1	112B5-112B14	71B5-90B14	112B5-112B14	71B5-90B14	112B5-112B14
	FC1-FR1		90B5-112B14		112B5-112B14	
	P1		71B5-90B14		112B5-112B14	
	F2	112B5-112B14	71B5-90B14	71B5-90B14	112B5-112B14	112B5-112B14
	FC2-FR2		90B5-112B14	112B5-112B14		
P2			112B5-112B14			
W/VF86/185	N	112B5-112B14	112B5-112B14	90B5-112B14	90B5-112B14	90B5-112B14
	A	90B5-112B14	112B5-112B14	112B5-112B14	112B5-112B14	112B5-112B14
	V	112B5-90B14				90B5-112B14
	F1	112B5-112B14	90B5-112B14	112B5-112B14	90B5-112B14	112B5-112B14
	FC1-FR1				112B5-112B14	
	P1				112B5-112B14	
	F2	112B5-112B14	90B5-112B14	90B5-112B14	112B5-112B14	112B5-112B14
	FC2-FR2			112B5-112B14		
P2			112B5-112B14			
VF/VF130/210	N	#	132B5	#	#	#
	A	132B5	#	132B5	132B5	132B5
	V					
	P					
VF/VF130/250	N	#	132B5	#	#	#
	A	132B5	#	132B5	132B5	132B5
	V		132B5			
	P		#			

Consultar a nuestro servicio

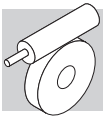

12.1 Orientación de la caja de conexiones

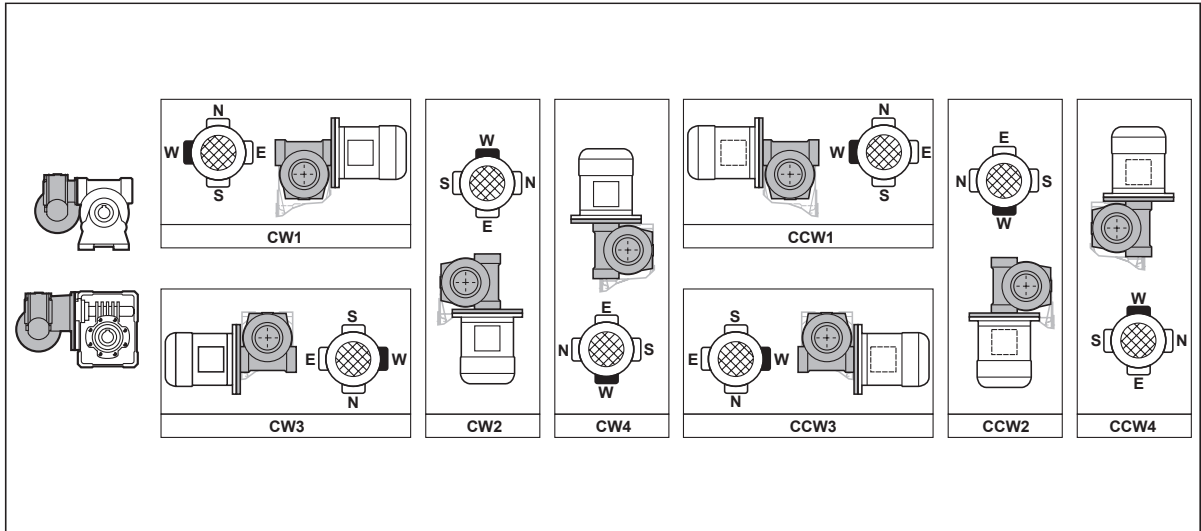



13 DESIGNACIÓN

REDUCTOR

W 63 L1 UF1 — 24 S2 — B3

OPCIONES

EJEC. DE MONTAJE

VF/VF, VF/W, W/VF	CW (1, 2, 3, 4) CCW (1, 2, 3, 4)
-------------------	---





















POSICIONES DE MONTAJE

VF 27...VF 49 VFR 44, VFR 49	B3
W, WR VF 130...VF 250 VFR 130...VFR 250	B3 (default), B6, B7, B8, V5, V6
VF/VF VF/W W/VF	 B3 (default), B6, B7, B8, V5, V6

FORMA CONSTRUCTIVA MOTORES IEC

B5	(VF 30...VF 250, VFR 49...VFR 250, W, WR)
B14	(VF 30...VF 49, W)

DESIGNACION ENTRADA

	VF	VFR	W	WR	VF/VF	VF/W	W/VF
P(IEC)	 P27 (VF 27 only), P56...P225	 P63, P80...P160	 P71...P132	 P63...P112	 P56, P63, P90...P132	 P56...P80	 P71...P112
S_		 S44 (VFR 44 only)	 S1...S3				 S1...S3
HS							

RELACIÓN DE REDUCCIÓN

DIÁMETRO DEL EJE DE SALIDA

W 75 VF/W 44/75	D30 (default), D28 (Bajo pedido)
--------------------	---

FORMA CONSTRUCTIVA

LIMITADOR DE PAR

VF, VFR W, WR	L1, L2	VF/VF	LF
------------------	---------------	-------	-----------

TAMAÑO DEL REDUCTOR

VF	27, 30, 44, 49, 130, 150, 185, 210, 250	VF/VF	30/44, 30/49, 130/210, 130/250
VFR	44, 49, 130, 150, 185, 210, 250	VF/W	30/63, 44/75, 44/86, 49/110
W, WR	63, 75, 86, 110	W/VF	63/130, 86/150, 86/185

TIPO DE REDUCTOR

VF, W	Reductor de tornillo sinfin
VFR, WR	Reductor con prerreductor helicoidal
VF/VF, VF/W, W/VF	Reductor combinado



MOTOR

FRENO

BN 63A 4 230/400-50 IP54 CLF W FD 3.5 R SB 220 SA

OPCIONES

ALIMENTACIÓN
FRENO

TIPO DE ALIMENTACIÓN
AC/DC
NB, SB, NBR, SBR

PALANCA DE DESBLOQUEO FRENO
R, RM

PAR DE FRENADO

TIPO DE FRENO
FD (freno c.c.)
FA (freno c.a.)

POSICIÓN CAJA DE CONEXIONES
W (default), **N, E, S**

FORMA CONSTRUCTIVA
— (motor integrado)
B5, B14 (motor IEC)

CLASE DE AISLAMIENTO
CL F standard
CL H option

GRADO DE PROTECCIÓN
IP55 standard (IP54 -autofr.)

TENSIÓN-FRECUENCIA

NÚMERO DE POLOS
2, 4, 6, 2/4, 2/6, 2/8, 2/12, 4/6, 4/8

TAMAÑO MOTOR
1SC ... 3LC (motor integrado)
56A ... 225M (motor IEC) BN 27, BN 44 (motor especiales)

TIPO MOTOR
M = trifásico integrado
BN = trifásico IEC





14 OPCIONES DE LOS REDUCTORES

LUBRICACIÓN

Los reductores VF 27, VF 30, VF 44, VF 49 y W 63, W 75, W 86 se llenan normalmente de fábrica con aceite en la versión estándar. Los reductores VF 130, VF 150, VF 185, VF 210, VF 250 y W 110 normalmente se suministran sin lubricar en la versión estándar.

Sin embargo, para todos los tamaños de reductores llenados de fábrica con aceite, es posible solicitar el suministro con más tipos de aceite, seleccionables según lo definido en la tabla (LUB. 01).

La aplicabilidad de la opción LUBRICACIÓN se describe en la tabla (LUB. 02).

LUBRICACIÓN	Tipo	Designación	Productor
LH	PoliGlicol (PAG)	OMALA S4 WE 150	
LS	PoliGlicol (PAG)	OMALA S4 WE 220	
LO* [1]	PoliGlicol (PAG)	OMALA S4 WE 320	
LK* [2]	PoliGlicol (PAG)	OMALA S4 WE 460	
LA	Grado alimenticio	KLUBERSYNTH UH1 6-150	
LB	Grado alimenticio	KLUBERSYNTH UH1 6-220	
LC [1]	Grado alimenticio	KLUBERSYNTH UH1 6-320	
LD [1]	Grado alimenticio	KLUBERSYNTH UH1 6-460	

* A menos que se especifique lo contrario, los reductores VF 27, VF 30, VF 44 y VF 49 suministrados con carga de lubricante "por vida" utilizan aceite OMALA S WE 320.

[1] Uso sugerido para reductores tipo VF, VFR, VF_EP, W, WR, W_EP.

[2] Uso obligatorio para reductores tipo VFL, WL.

	LUBRICACIÓN					
	Posición de montaje					
	B3	B6	B7	B8	V5	V6
W 110 U-UF-UFC	X	X	X	X	⊖	⊖
VF 130 A-N-P-F-FC	X	X	X	X	⊖	⊖
VF 130 V	⊖	X	X	⊖	X	X
VF 130 FR	X	⊖	⊖	X	⊖	⊖
VF 150 A-N-P-F-FC	X	X	X	X	⊖	⊖
VF 150 V	⊖	X	X	⊖	X	X
VF 150 FR	X	⊖	⊖	X	⊖	⊖
VF 185 A-N-P-F-FC	X	X	X	X	⊖	⊖
VF 185 V	⊖	X	X	⊖	X	X
VF 185 FR	X	⊖	⊖	X	⊖	⊖
VF 210 A-N-P	X	⊖	⊖	X	⊖	⊖
VF 210 V	⊖	⊖	⊖	⊖	X	X
VF 250 A-N-P	X	⊖	⊖	X	⊖	⊖
VF 250 V	⊖	⊖	⊖	⊖	X	X

SO

Los reductores tipo VF 27 ... VF 49, W 63 ... W 86, que se suministran exclusivamente llenados en fábrica con lubricante, en este caso se suministran sin aceite.



RB

Doble eje de entrada (excluido el VF 27).

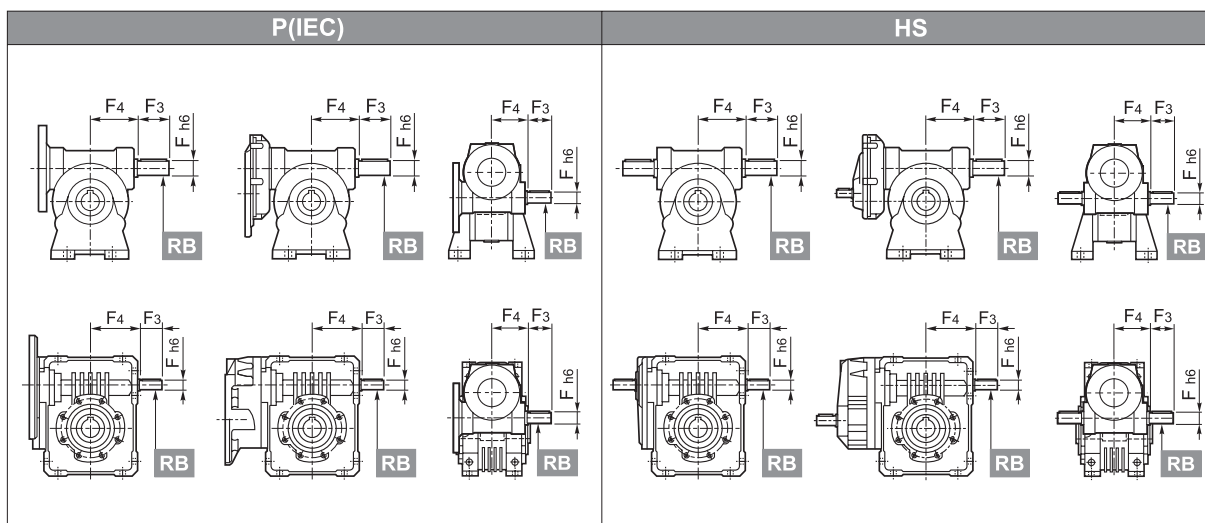

RBO

Doble eje de entrada en el 2º Reductor (sólo para combinados).

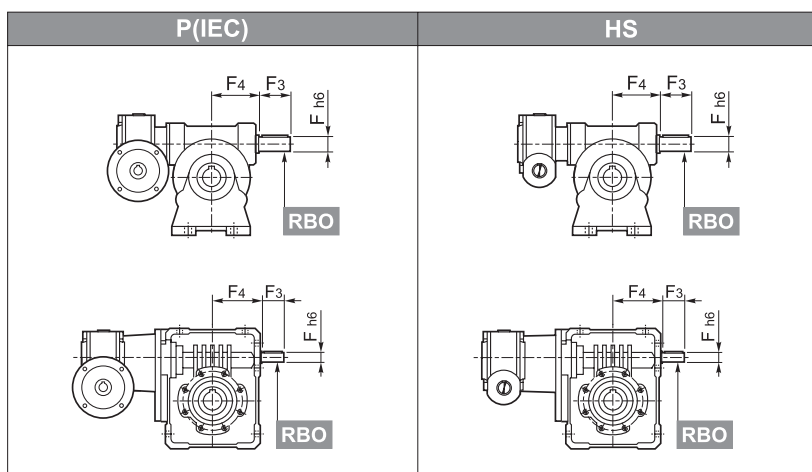

Eje de entrada (opciones RB y RBO)								
		F	F1	F2	F3	F4	V	
	VF	30	9	10.2	3	20	50	—
	VFR	44	11	12.5	4	30	56	—
	VF/VF	49	16	18	5	40	65	M6
	W	63	18	20.5	6	40	74	M6
	WR	75	19	21.5	6	40	88.5	M6
	VF/W	86	25	28	8	50	101.5	M8
		110	25	28	8	60	127.5	M8
	VF	130	30	33	8	60	160	M8
	VFR	150	35	38	10	65	185	M8
	W/VF	185	40	43	12	70	214.5	M8
		210	48	51.5	14	82	185	M16x40
	250	55	59	16	82	228	M16x40	

Para los VF 210 y VF 250, en las formas constructivas **A** y **P**, normalmente viene montado el ventilador de refrigeración; con la opción **RB** no se puede aplicar.



VV

Retén en fluoro-elastómero en el eje de entrada. Disponible solo para W110 y para la Serie VF (excluyendo VF30 con opción RB y VF30_HS).

PV

Todos los retenes en fluoro-elastómero (excluyendo VF30 con opción RB y VF30_HS).

KA

Kit con patas W 63...W 110 para la intercambiabilidad con los grupos tipo VF_A equivalentes.

KV

Kit con patas W 63...W 110 para la intercambiabilidad con los grupos tipo VF_V equivalentes (excluyendo W con opción RB y W 110 en la posición de montaje B6).

AO

Eje lado opuesto al estándar (VF27).

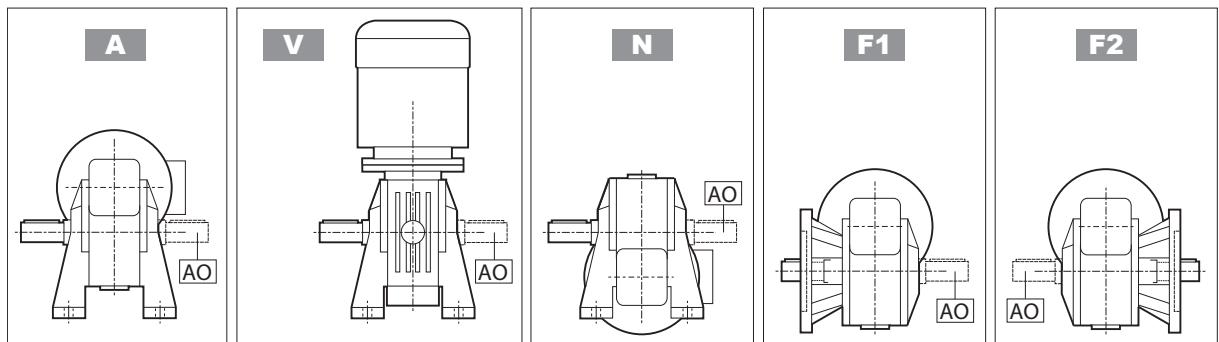

BP

Los reductores, que generalmente se suministran con un tapón de ventilación abierto, se suministran con un tapón de ventilación de válvula. La calibración de la válvula puede variar de 0,10 a 0,15 bar dependiendo del tipo de tapón. La válvula se abre a intervalos y permite la ventilación de la presión interna evitando la entrada de cuerpos extraños.

Para conocer la disponibilidad de opciones, consulte el capítulo "Posiciones de montaje y tapón de servicio" del Manual de instalación, operación y mantenimiento (disponible en: www.bonfiglioli.com).

Si es necesario, póngase en contacto con el Servicio Técnico de Bonfiglioli.

BRAZO DE REACCION

Los reductores VF 30...VF 250 y W 63...W 110 se suministran con el brazo de reacción montado

Es posible solicitar el brazo de reacción montado en varias posiciones como se muestra (TA1, TA2, TA1B, TA2B, TA1D, TA2D).

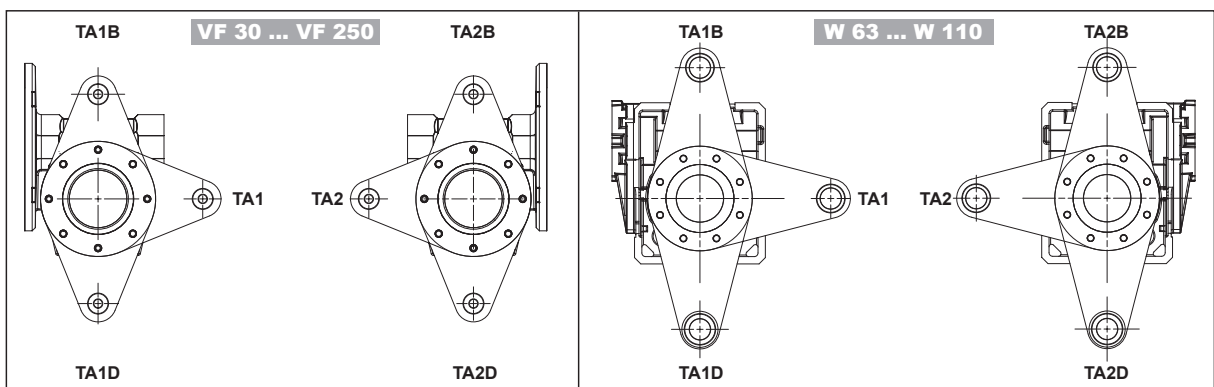



La aplicabilidad de la opción BRAZO DE REACCIÓN se describe en la siguiente tabla.

		BRAZO DE REACCIÓN	
		TA1 - TA1B - TA1D	TA2 - TA2B - TA2D
VF VFR VF/VF W/VF	VF 30 ... VF 49 F1	⊖	X
	VF 30 ... VF 49 F2	X	⊖
	VF 44 - VF 49 FA1	⊖	X
	VF 44 - VF 49 FA2	X	⊖
	VF 30 ... VF 49 P1	X	X
	VF 210 - VF 250 P1	X	X
	VF 130 ... VF 185 P1	X	⊖
W WR VF/W	VF 130 ... VF 185 P2	⊖	X
	W 63 ... W 110 U	X	X
	W 63 ... W 110 UF1 - UFC1	⊖	X
	W 63 ... W 110 UF2 - UFC2	X	⊖
	W 75 UFCR1	⊖	X
	W 75 UFCR2	X	⊖

La opción no se puede montar en los reductores VFL - WL en el lado donde está previsto el limitador de par.

La opción no es compatible con el TAPÓN DE PROTECCIÓN si se dispone en el mismo lado.

TAPÓN DE PROTECCIÓN

Los reductores W-WR 63-75-86-110 se suministran con tapón de protección para el eje de salida (en material plástico).

Es posible solicitar el brazo de torsión montado en varias posiciones como se muestra (SC1, SC2).

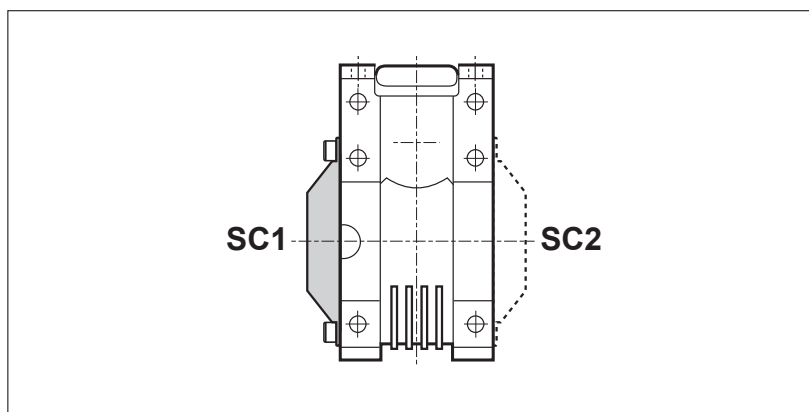

La aplicabilidad de la opción TAPÓN DE PROTECCIÓN se describe en la siguiente tabla.

		TAPÓN DE PROTECCIÓN	
		SC1	SC2
W WR VF/W	W 63 ... W 110 U	X	X
	W 63 ... W 110 UF1 - UFC1	⊖	X
	W 63 ... W 110 UF2 - UFC2	X	⊖
	W 75 UFCR1	⊖	X
	W 75 UFCR2	X	⊖

La opción no se puede montar en los reductores VFL - WL en el lado donde está previsto el limitador de par. La opción no es compatible con el BRAZO DE REACCION si se proporciona en el mismo lado.

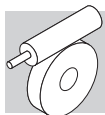

PROTECCIÓN DE LA SUPERFICIE

Cuando no se requiere ninguna clase de protección específica, las superficies de los reductores (ferrosas) pintadas están protegidas al menos con la clase de corrosividad C2 (UNI EN ISO 12944-2). Para mejorar la resistencia a la corrosión atmosférica, los reductores se pueden entregar con una protección de superficie **C3** y **C4**, que se obtiene a partir del pintado completo del reductor.

PROTECCIÓN SUPERFICIE	Ambientes típicos	Temperatura máxima superficie	Clase corrosividad conforme a UNI EN ISO 12944-2
C3	Ambientes industriales y urbanos con una humedad relativa de hasta el 100% (contaminación atmosférica media)	120°C	C3
C4	Zonas industriales, zonas costeras, fábrica de productos químicos, con una humedad relativa de hasta el 100% (alta contaminación atmosférica)	120°C	C4

Los reductores con la protección opcional de clase **C3** o **C4** están disponibles en una variedad de colores.

Si no se solicita color específico (ver la opción "PINTURA") el acabado de los reductores será en RAL 7042.

Los reductores también se pueden suministrar con protección de la superficie para la clase de corrosividad **C5** según la norma UNI EN ISO 12944-2. Póngase en contacto con nuestro Servicio Técnico para más detalles.

PINTURA

Los reductores con la protección opcional de clase C3 o C4 están disponibles en los colores que figuran en la siguiente tabla.

PINTURA	Color	Número RAL
RAL7042*	Gris Tráfico A	7042
RAL5010	Azul genciana	5010
RAL9005	Negro Jet	9005
RAL9006	Aluminio Blanco	9006
RAL9010	Blanco Puro	9010
RAL7035	Gris claro	7035
RAL7001	Gris-plata	7001
RAL5015	Azul cielo	5015
RAL7037	Gris polvoriento	7037
RAL5024	Azul pastel	5024

* Los reductores se suministran en este color estándar si no se especifica ningún otro color.

NOTA - Las opciones "PINTURA" sólo se pueden especificar en combinación con las opciones "PROTECCIÓN DE LA SUPERFICIE".



DOCUMENTACIÓN

Certificado de conformidad (AC)

Documento en el cual se certifica la conformidad del producto con lo indicado en el pedido y su fabricación según los procedimientos estándar de producción y control que establece el sistema de calidad de Bonfiglioli Riduttori.

Certificado de prueba (CC)

La obtención de este certificado conlleva verificar la conformidad del producto con el pedido, realizar inspecciones visuales de carácter general y comprobar las dimensiones de acoplamiento. Además, exige realizar controles generales de funcionamiento en vacío y comprobar la eficacia de las juntas de retén con el sistema estático y en funcionamiento. Para llevar a cabo la prueba se utiliza una muestra estadística del lote de expedición.

Opciones de los motores

Para más información sobre las opciones, consultar el correspondiente capítulo en la sección de Motores Eléctricos.



15 POSICION DE MONTAJE Y ORIENTACIÓN DE LA CAJA DE BORNES

La orientación de la caja de bornes del motor se identifica observando el motor por el lado del ventilador; la orientación estándar está resaltada en negrita (W).

Las posiciones representadas de la caja no son validas para VFR 44. Consultar la Pág. 19 y las pag.116-117 para la designación y la identificación de la forma constructiva.

Posición angular de la palanca del desbloqueo del freno

En los motores freno, la palanca de desbloqueo del freno (opcional) tiene la orientación estándar a 90° respecto a la caja de bornes (posición AB); en caso de requerir una orientación distinta, especifíquese mediante los correspondientes códigos de opciones.

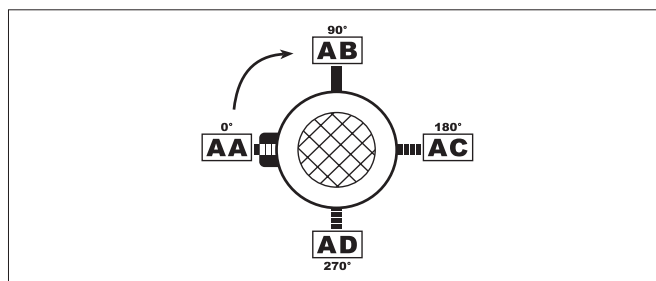

En las páginas siguientes se describen las posiciones de montaje de los reductores VF y W.

Para los reductores combinados tipo VF/VF, VF/W y W/VF las posiciones de montaje se refieren al segundo reductor (lado máquina), para el primer reductor (lado motor) hacer referencia al capítulo "Ejecuciones de montaje".



VF 27 _ ... VF 49 _

VFR 44 _ , VFR 49 _

				_HS	_S - _P (IEC)		
A	B3	B7	V5				← VF
	B6	B8	V6				← VFR*
N	B3	B7	V5				← VF
	B6	B8	V6				← VFR*
V	B3	B7	V5				← VF
	B6	B8	V6				← VFR*
P	B3	B7	V5				← VF
	B6	B8	V6				← VFR*
F	B3	B7	V5				← VF
	B6	B8	V6				← VFR*
U	B3	B7	V5				← VF
	B6	B8	V6				← VFR*

Posición de montaje base.

Los reductores están marcados únicamente con la posición de montaje base (B3). Sin embargo, pueden también ser instalados en cualquiera de las posiciones derivadas (B6, B7, B8, V5, V6). La posición de montaje no se debe cambiar después de efectuada la instalación.

* Las posiciones representadas de la caja no son validas para VFR 44. Consultar la Pág. 19 y las pag.116-117 para la designación y la identificación de la forma constructiva.



W 63 U ... W 110 U

WR 63 U ... WR 110 U

_HS

_S - _P (IEC)

B3

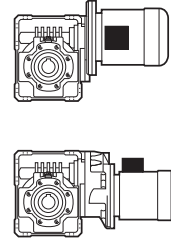
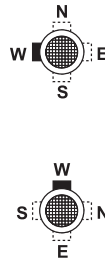
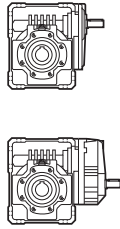
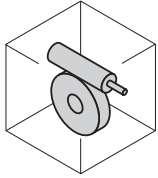

B6

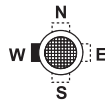
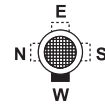
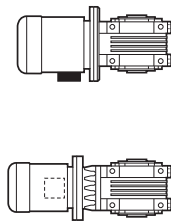
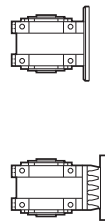
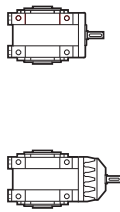
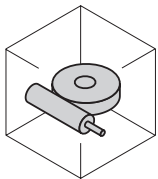

B7

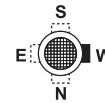
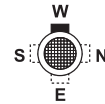
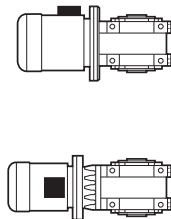
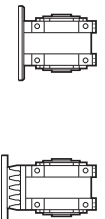
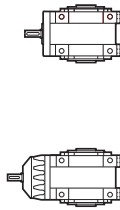
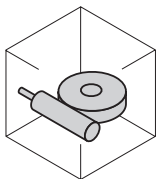

B8

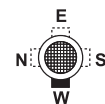
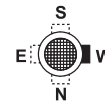
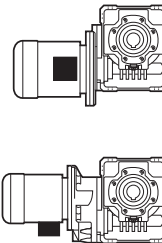
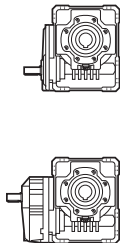
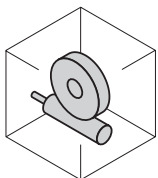

V5

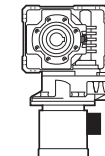
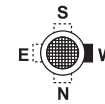
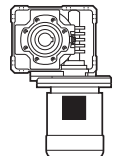
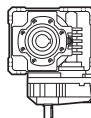
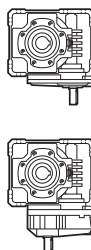
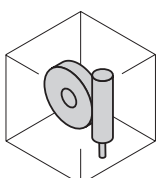



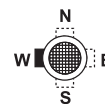
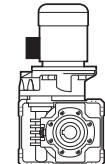
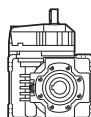
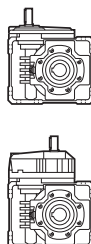
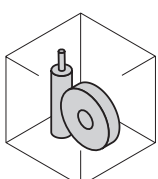

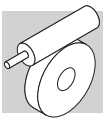



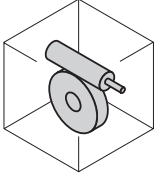
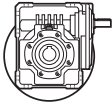
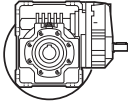
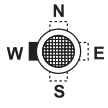
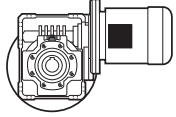

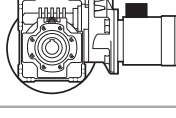

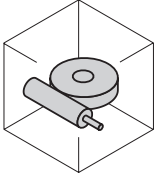
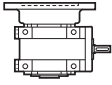
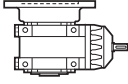
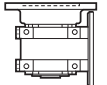
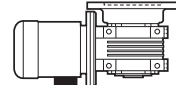

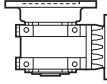
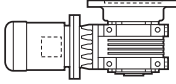
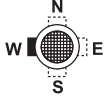

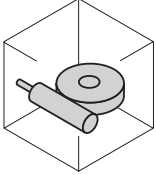
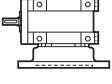
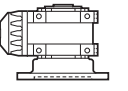
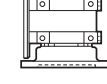
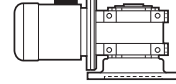

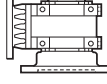
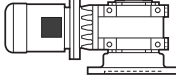

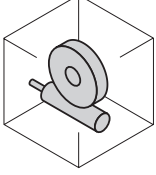
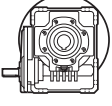
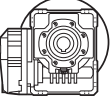
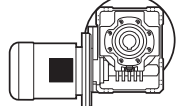
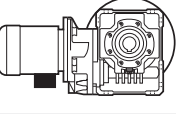
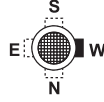

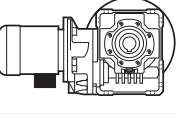
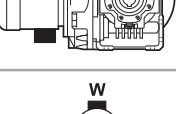

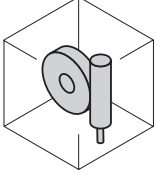
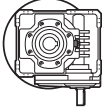
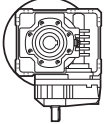

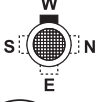
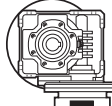

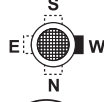
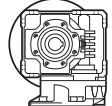

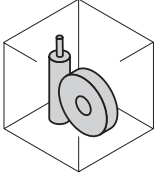
V6

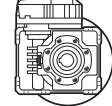

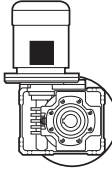

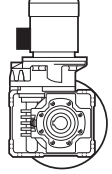
W 63 UF/UFC ... W 110 UF/UFC WR 63 UF/UFC ... WR 110 UF/UFC

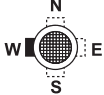
	_HS	_S - _P (IEC)	
B3	  	  	  
B6	  	   	   
B7	  	   	   
B8	  	   	   
V5	  	   	  
V6	  	   	  



VF 130 A ... VF 250 A

VFR 130 A ... VFR 250 A

_HS

_P (IEC)

B3

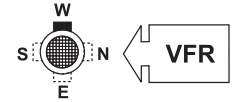
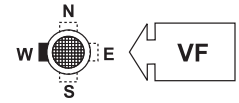
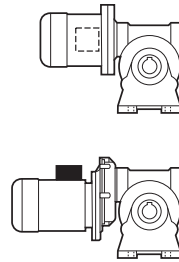
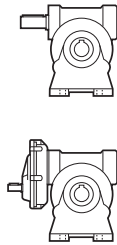
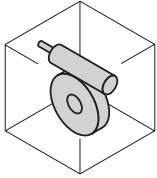

B6

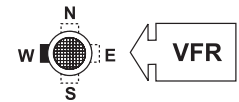
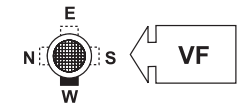
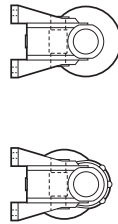
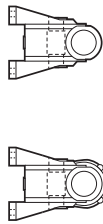
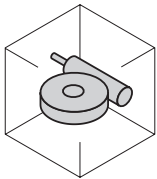

B7

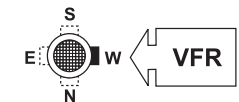
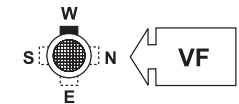
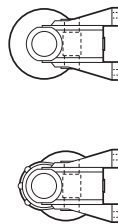
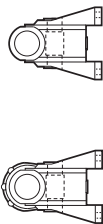
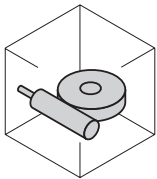

B8

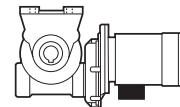
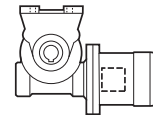
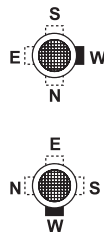
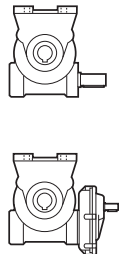
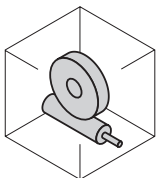

V5

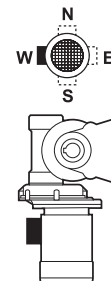
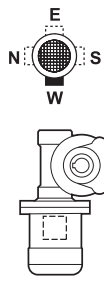
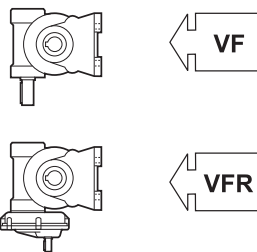
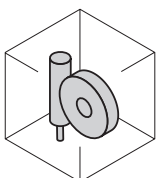

V6

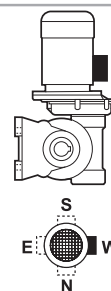
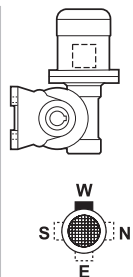
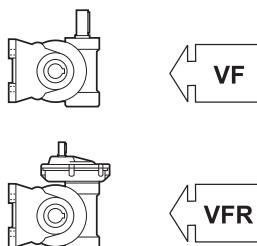
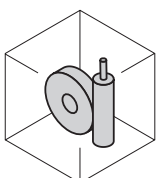



VF 130 N ... VF 250 N VFR 130 N ... VFR 250 N

	_HS		_P (IEC)	
B3				
B6				
B7				
B8				
V5		 	 	
V6		 	 	



VF 130 V ... VF 250 V

VFR 130 V ... VFR 250 V

_HS

_P (IEC)

B3

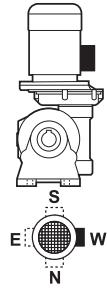
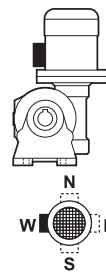
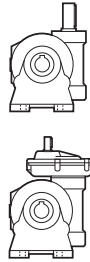
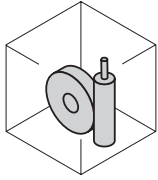

B6

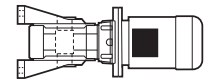
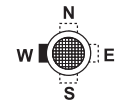
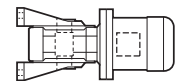
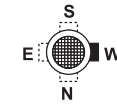
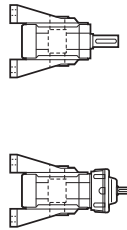
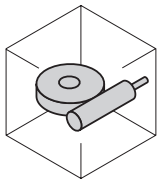

B7

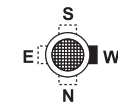
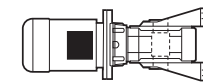
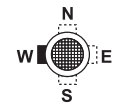
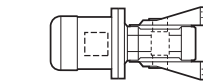
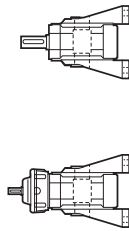
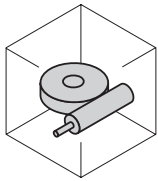

B8

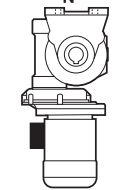
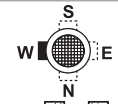
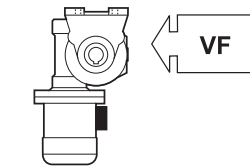
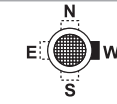
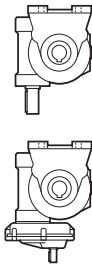
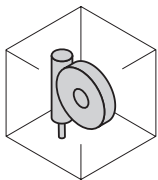

V5

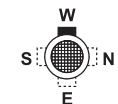
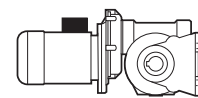
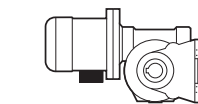
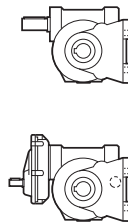
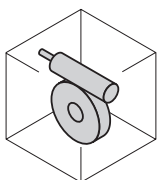

V6

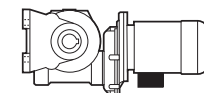
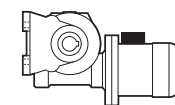
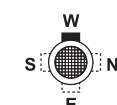
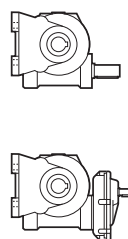
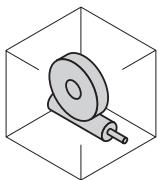



VF 130 P ... VF 250 P VFR 130 P ... VFR 250 P

_HS

_P (IEC)

B3

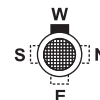
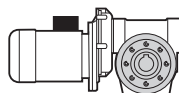
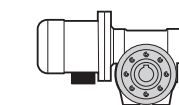
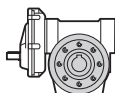
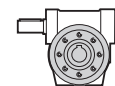
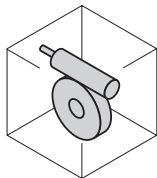

B6

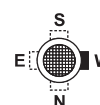
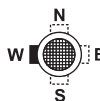
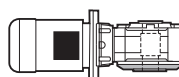
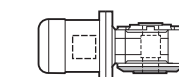
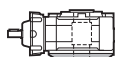
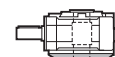
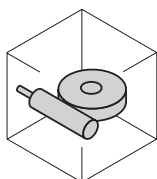

B7

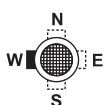
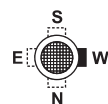
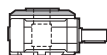
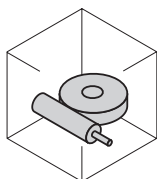

B8

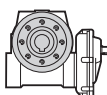
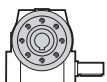
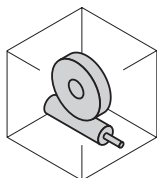

V5

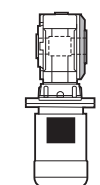
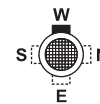
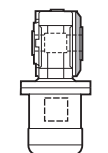
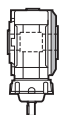
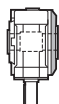
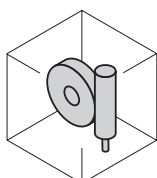

V6

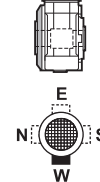
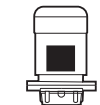
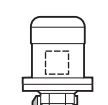
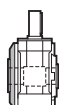
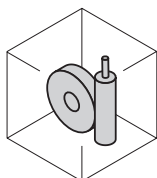



VF 130 F ... VF 250 F

VFR 130 F ... VFR 250 F

_HS

_P (IEC)

B3

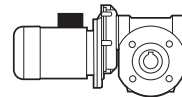
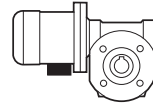
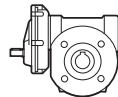
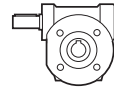
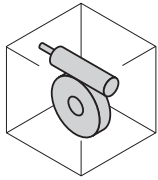

B6

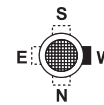
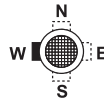
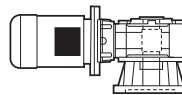
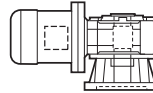
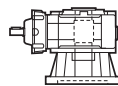
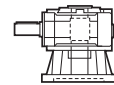
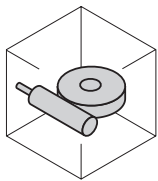

B7

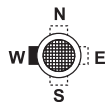
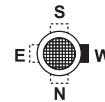
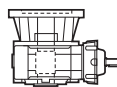
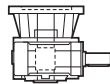
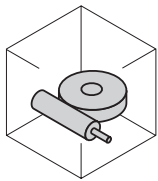

B8

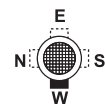
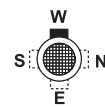
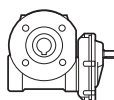
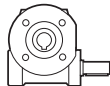
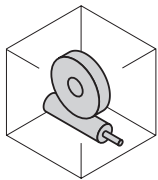

V5

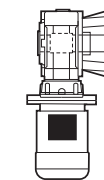
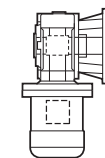
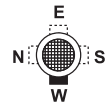
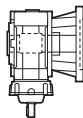
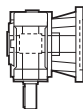
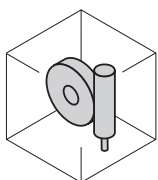

V6

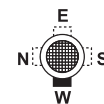
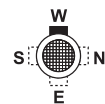
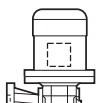
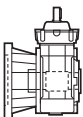
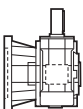
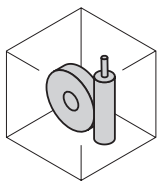



16 CARGAS RADIALES

16.1 Fuerza resultante sobre el eje

Los órganos de transmisión montados sobre los ejes de entrada y/o de salida del reductor, generan fuerzas cuya resultante actúan sobre el propio eje en sentido radial.

La identidad de estas cargas debe ser compatible con la capacidad de soportarlas el sistema eje - rodamientos del reductor, en particular el valor absoluto de la carga aplicada (R_{c1} para el eje de entrada, R_{c2} para el eje de salida) debe ser inferior al valor nominal (R_{n1} para el eje de entrada, R_{n2} para el eje de salida) indicado en la tablas de datos técnicos.

El procedimiento abajo descrito se aplica indistintamente tanto al eje de entrada como al eje de salida, teniendo presente utilizar la constante relativa al eje correspondiente en el cálculo. La carga generada por una transmisión externa puede calcularse con buena aproximación, empleando la fórmula siguiente.

$$R_c = \frac{2000 \times M \times K_r}{d}$$

$K_r = 1$		M [Nm]	
$K_r = 1.25$		d [mm]	
$K_r = 1.5 - 2.0$			

16.2 Verificación resistencia Radial

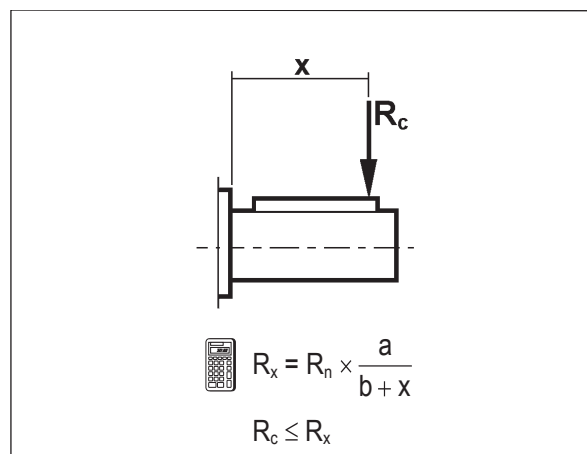
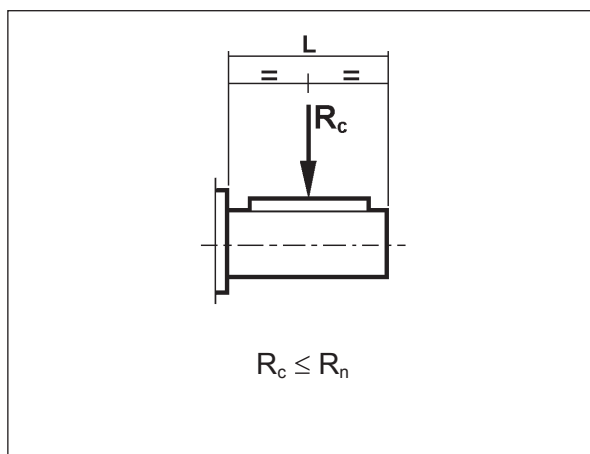



16.3 Constantes del reductor

	Eje de salida		$R_{n2} \text{ max}$ [N]
	a	b	
VF 27	56	44	600
VF 30	60	45	1700
VF 44 - VFR 44 - VF/VF 30/44	71	51	2500
VF 49 - VFR 49 - VF/VF 30/49	99	69	3450
W 63 - WR 63 - VF/W 30/63	132	102	5000
W 75 - WR 75 - VF/W 44/75	139	109	6200
W 86 - WR 86 - VF/W 44/86	149	119	7000
W 110 - WR 110 - VF/W 49/110	173	136	8000
VF 130 - VFR 130 - W/VF 63/130	182	142	13800
VF 150 - VFR 150 - W/VF 86/150	198	155	16000
VF 185 - VFR 185 - W/VF 86/185	220	170	19500
VF 210 - VFR 210 - W/VF 130/210	268	203	34500
VF 250 - VFR 250 - W/VF 130/250	334	252	52000

17 CARGAS AXIALES

Los valores de las cargas axiales admisibles por los ejes de entrada $[A_{n1}]$ y el de salida $[A_{n2}]$ se pueden obtener con referencia al correspondiente valor de la carga radial $[R_{n1}]$ y $[R_{n2}]$ mediante la expresión siguiente:

$$\begin{aligned} A_{n1} &= R_{n1} \times 0,2 \\ A_{n2} &= R_{n2} \times 0,2 \end{aligned} \quad (14)$$

Los valores de cargas axiales admisibles así calculados, se refieren al caso de fuerzas axiales que actúan contemporáneamente con las cargas radiales nominales.

En el caso que el valor de la carga radial resultante sea nulo, se puede considerar la carga axial admisible $[A_n]$ igual al 50 % del valor de la carga radial admisible $[R_n]$ sobre el mismo eje.

En presencia de cargas axiales que excedan el valor admisible, o de fuerzas axiales fuertemente relevantes sobre la carga radial, es aconsejable dirigirse al Servicio Técnico de Bonfiglioli Riduttori para una verificación puntual.



17.1 Cargas axiales máximas admisibles en la forma constructiva FR

Para satisfacer aquellas aplicaciones que precisan cargas axiales muy elevadas, está disponible la forma constructiva FR prevista para los tamaños VF 130, VF 150 y VF 185. Esta forma constructiva, cuyas dimensiones exteriores son idénticas que las de la forma FC, puede soportar las cargas axiales (notablemente superiores a las admisibles por la forma estándar) indicadas en la tabla siguiente referidas a la relación de transmisión i y al sentido de giro +/- del eje de salida.

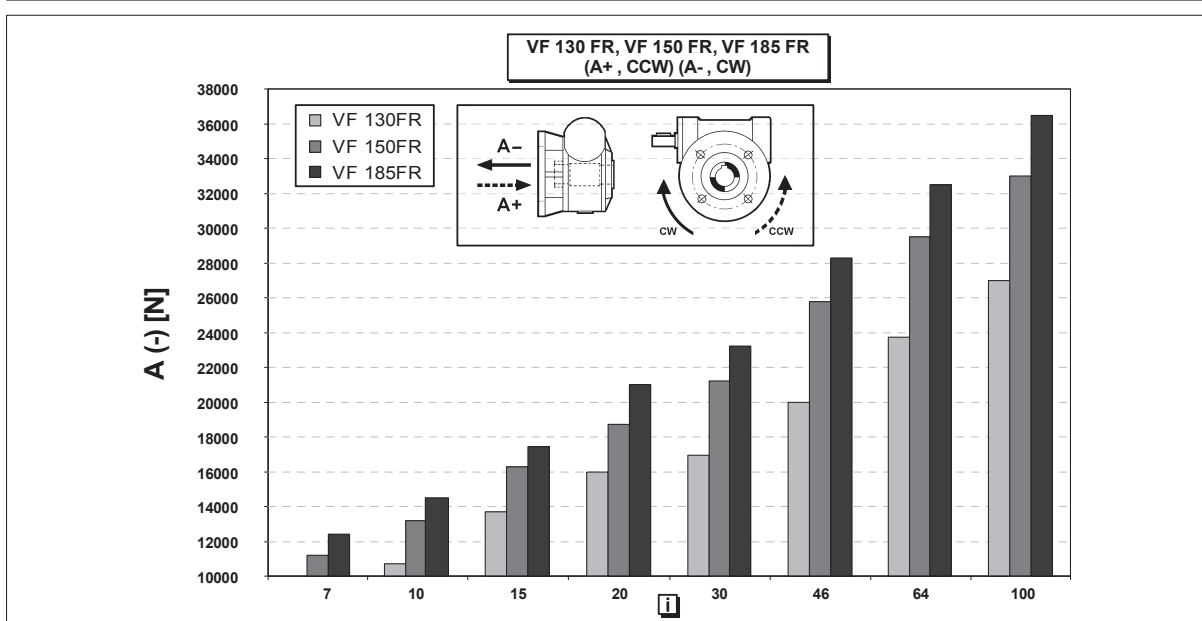
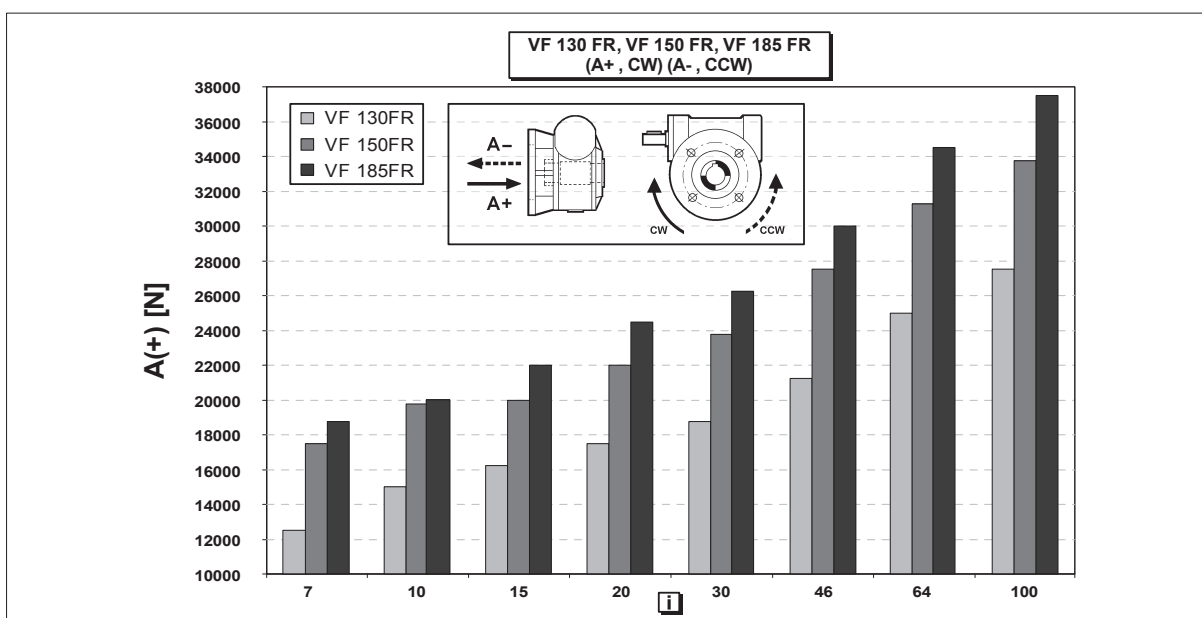
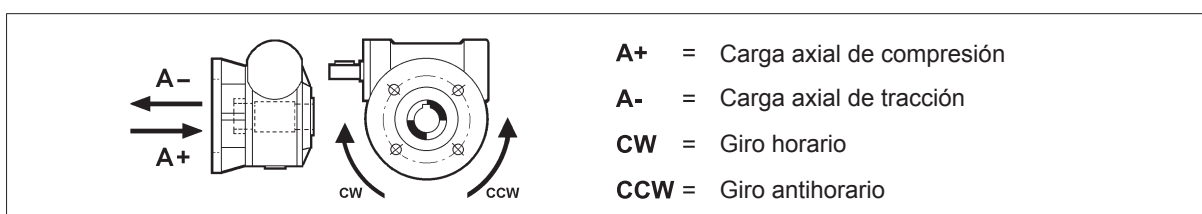

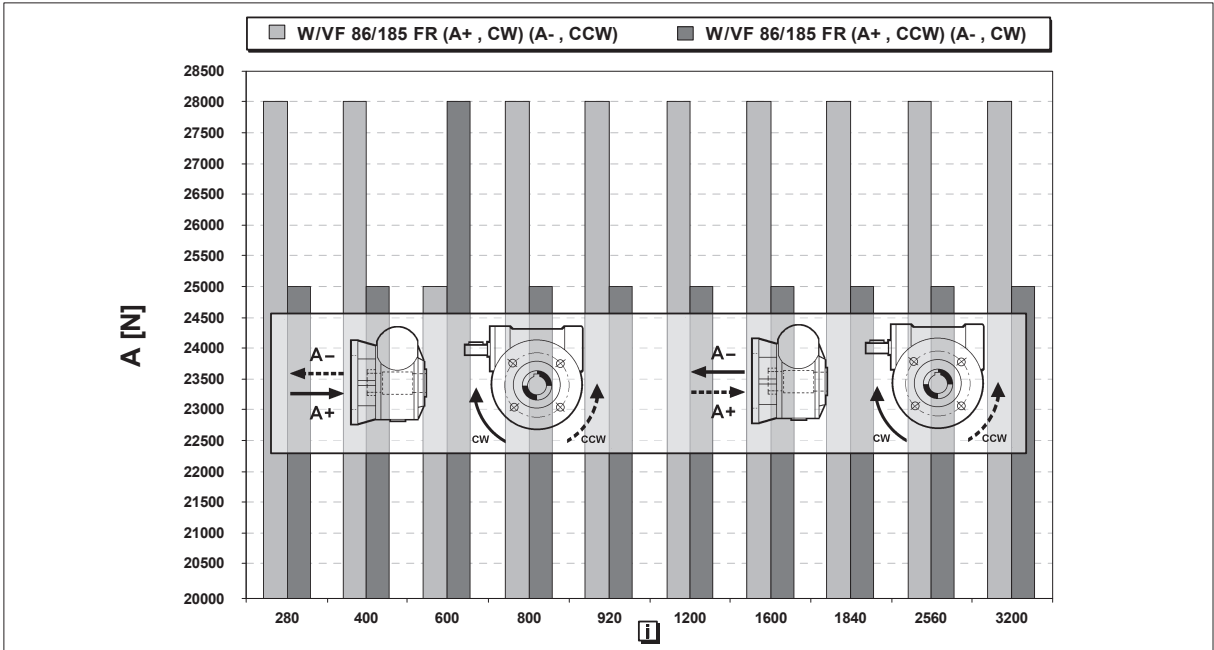
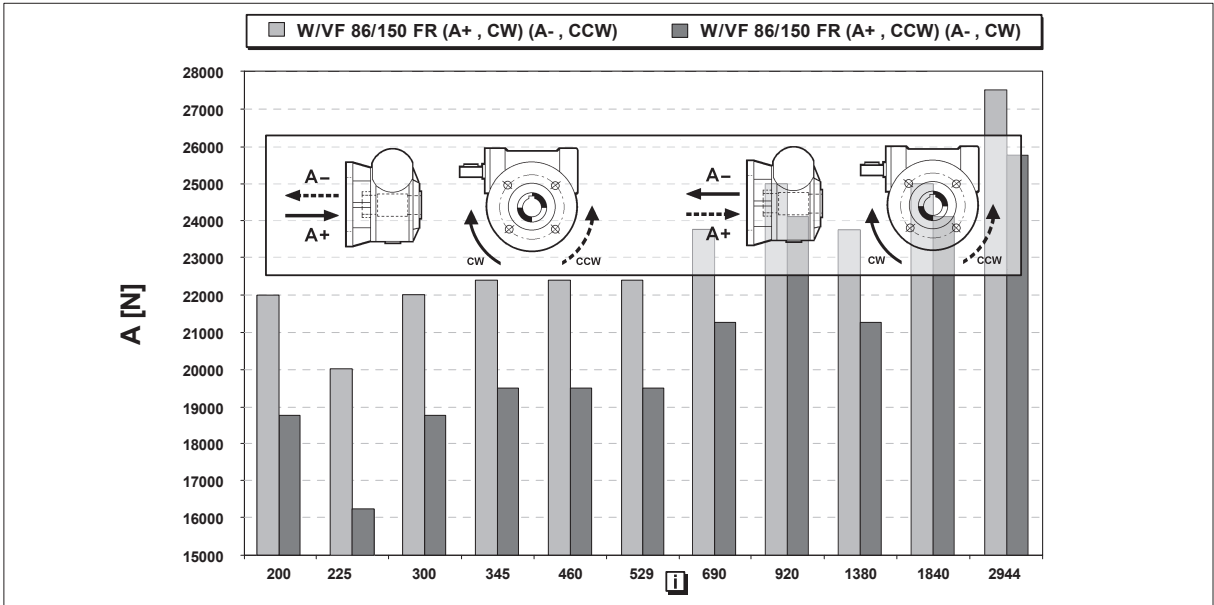
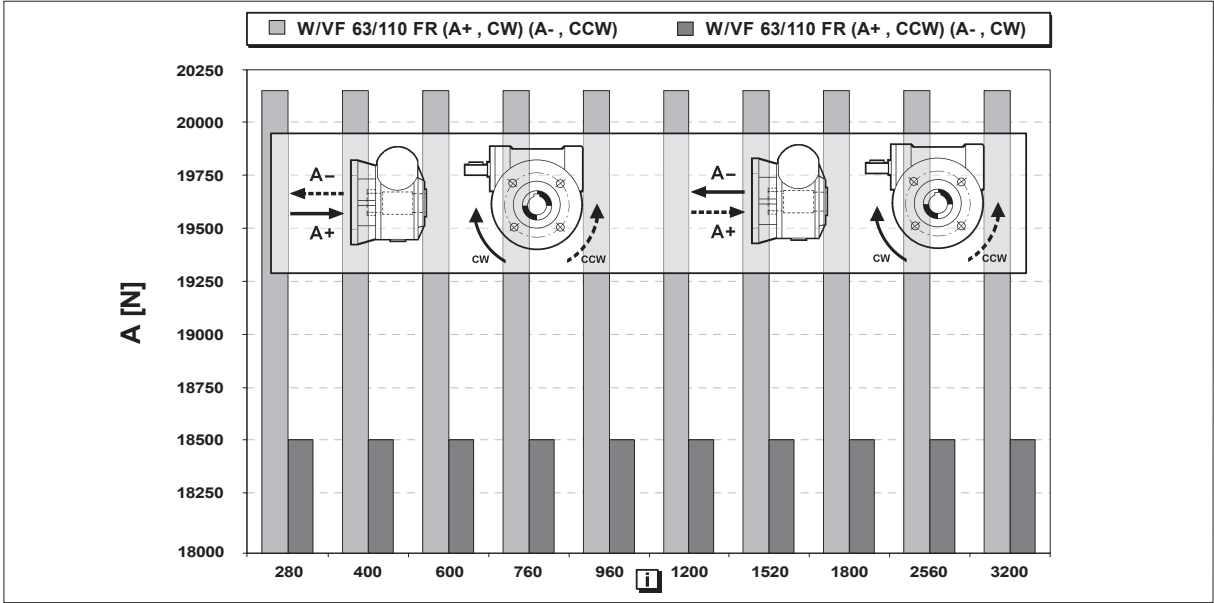



18 RENDIMIENTO

El rendimiento $[\eta]$ depende de los siguientes parámetros

- ángulo de inclinación de la hélice del engranaje
- velocidad de giro
- rodaje del engranaje

Con tal propósito, es útil recordar que el valor óptimo, se obtiene después de unas horas de rodaje y viene reducido gradualmente con los reductores funcionando a régimen, como queda reflejado en la tabla abajo indicada, por este motivo, en determinadas aplicaciones donde se prevé un servicio intermitente (elevación, accionamientos, etc.) es necesario incrementar adecuadamente la potencia del motor con el fin de compensar el bajo rendimiento del reductor en la fase de arranque.

Los valores de par nominal M_{n2} indicados en el catálogo están referidos al funcionamiento a régimen después del rodaje.

La tabla indica, a modo indicativo, el tiempo necesario para obtener el máximo rendimiento Dinámico.

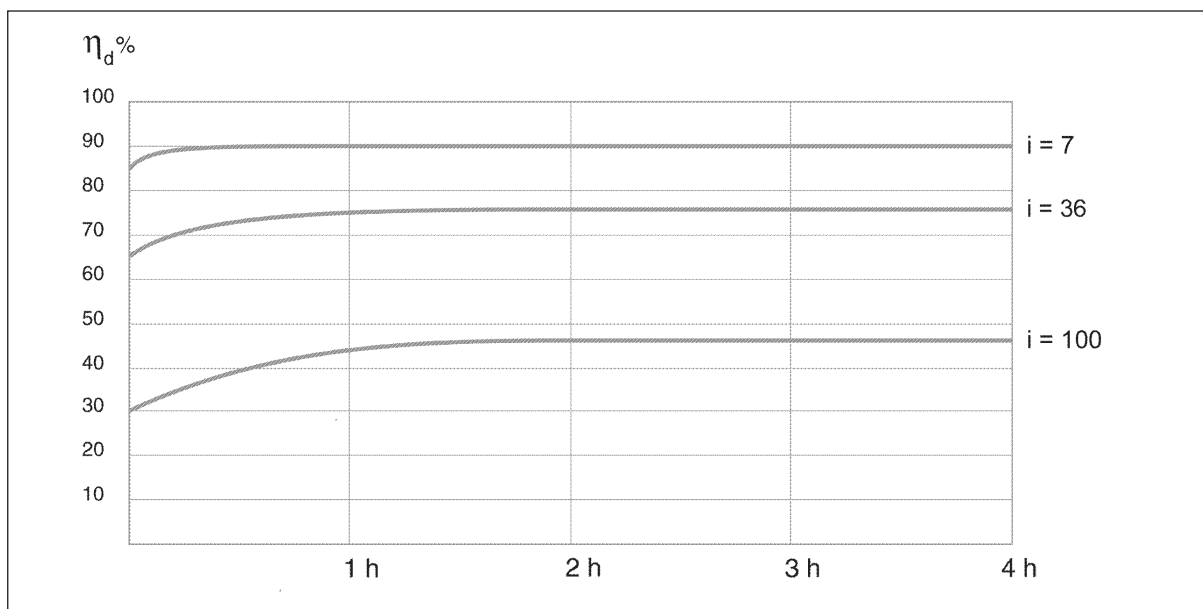

19 IRREVERSIBILIDAD

Algunas aplicaciones pueden precisar ocasionalmente que la transmisión del movimiento se realice a partir del eje de salida, mientras otras impongan que la carga sea retenida en la posición del motorreductor, aún en ausencia de corriente eléctrica.

Algunos grupos de tornillo sinfín presentan la característica de ser irreversibles y el parámetro que influye mayormente en esta prestación es el rendimiento.

En particular, el rendimiento estático η_s es responsable de la irreversibilidad estática (partiendo de una posición de reposo), mientras que el rendimiento dinámico η_d es responsable de la eventual irreversibilidad dinámica (continuidad del movimiento en la misma dirección).

La irreversibilidad puede expresarse en diversos valores con relaciones más altas ($i = 64$ y superiores) comportando siempre una mayor irreversibilidad.



19.1 Irreversibilidad estática

Con esta condición no puede existir la posibilidad de giro con movimiento desde eje de salida, sin excluir la posibilidad de un retorno lento, en el caso que los grupos estén sometidos a vibraciones. La condición teórica para que se cumpla la irreversibilidad estática es la siguiente:

$$\eta_s < 0.4 - 0.5 \quad (15)$$

donde η_s representa el rendimiento estático (valor incluido en las tablas de datos técnicos de los reductores). Obviamente, para cumplir la condición inversa, es decir, la reversibilidad estática, se deberá cumplir:

$$\eta_s > 0.5 \quad (16)$$

19.2 Irreversibilidad dinámica

Esta condición está influenciada directamente por la velocidad de giro, del rendimiento y de las vibraciones continuas de la carga. Se caracteriza por la detención casi instantánea del giro, cuando el eje del tornillo no esté en condiciones de continuar el movimiento.

Ésta está expuesta a la condición Teórica:

$$\eta_d < 0.5 \quad (17)$$

donde η_d representa el rendimiento dinámico del reductor en condiciones reales de funcionamiento (valor incluido en las tablas de datos técnicos de los reductores).

La condición inversa, es decir, la reversibilidad dinámica, físicamente es posible cuando se Cumple:

$$\eta_d > 0.5 \quad (18)$$

La tabla siguiente resume de forma indicativa distintos grados de reversibilidad en función del tipo de reductor y de la relación de reducción (datos referidos solamente al conjunto vis-corona). Evidentemente estos datos son orientativos por cuanto puede existir una irreversibilidad más o menos acentuada a causa de la influencia de los factores citados anteriormente.



Siendo prácticamente imposible realizar y garantizar la irreversibilidad total es necesario, donde exista esta exigencia, prever un freno externo suficiente para impedir el inicio del movimiento por efecto de vibraciones.



		Grado de reversibilidad												
		VF				W				VF				
Reversibilidad estática	Reversibilidad dinámica	27	30	44	49	63	75	86	110	130	150	185	210	250
si	si	—	—	7	7	7	7	7	7	7	7	7	7	7
si	si	7 10	7 10	10 14	10 14	10 12 15	10 15	10 15 20 23	10 15 20 23	10 15 20 23	10 15 20 23	10 15 20 23	10 15 20 23	10 15 20 23
incerta	si	15 20 30	15 20 30	20 28 35	18 24 28 36	19 24 30 38	20 25 30 40	30 40 46 56	30 40 46 56	30 40 46 56 64	30 40 46 56 64	30 40 50 60	30 40 50 60	30 40 50 60
no	bassa	40 60	40 60	46 60 70	45 60 70	45 64 80	50 60 80	64 80 100	64 80 100	80 100	80 100	80 100	60 80 100	80 100
no	no	70	70	100	80 100	100	100	—	—	—	—	—	—	—

20 JUEGOS ANGULARES

La tabla siguiente muestra los valores indicativos del juego angular referidos al eje de salida, con el eje de entrada bloqueado.







La medición ha de efectuarse aplicando un par de 5 Nm en el eje de salida.

Juegos angulares (eje de entrada bloqueado)		
	$\Delta\gamma$ [']	$\Delta\gamma$ [rad]
VF 30	33' ± 10'	0.00873 ± 0.00291
VF 44	25' ± 7'	0.00728 ± 0.00145
VFR 44	30' ± 10'	0.00873 ± 0.00291
VF 49	22' ± 7'	0.00728 ± 0.00145
VFR 49	30' ± 10'	0.00873 ± 0.00291
W 63	20' ± 4'	0.00582 ± 0.00145
WR 63	25' ± 5'	0.00728 ± 0.00145
W 75	18' ± 4'	0.00582 ± 0.00145
WR 75	22' ± 5'	0.00640 ± 0.00145
W 86	15' ± 4'	0.00436 ± 0.00145
WR 86	20' ± 5'	0.00582 ± 0.00145
W 110	9' ± 2'	0.00436 ± 0.00145
WR 110	18' ± 5'	0.00524 ± 0.00145
VF 130	12' ± 3'	0.00349 ± 0.00087
VFR 130	15' ± 3'	0.00436 ± 0.00087
VF 150	12' ± 3'	0.00349 ± 0.00087
VFR 150	15' ± 3'	0.00436 ± 0.00087
VF 185	10' ± 3'	0.00291 ± 0.00087
VFR 185	13' ± 3'	0.00378 ± 0.00087
VF 210	Consultar	
VFR 210		
VF 250		
VFR 250		









21 TABLAS DE SELECCIÓN DE LOS MOTORREDUCTORES







0.04 kW

n ₂ min ⁻¹	M ₂ Nm	S	i	Rn ₂ N						IEC 	
19.3	9	1.0	70	600	—	—	—	VF 27_70	P27	BN27A4	111
22.5	8	1.1	60	600	—	—	—	VF 27_60	P27	BN27A4	111
34	6	1.4	40	600	—	—	—	VF 27_40	P27	BN27A4	111
45	5	1.7	30	600	—	—	—	VF 27_30	P27	BN27A4	111
68	4	2.2	20	600	—	—	—	VF 27_20	P27	BN27A4	111
90	3	2.8	15	600	—	—	—	VF 27_15	P27	BN27A4	111
135	2	3.8	10	600	—	—	—	VF 27_10	P27	BN27A4	111
193	2	5.5	7	600	—	—	—	VF 27_7	P27	BN27A4	111

0.06 kW







n ₂ min ⁻¹	M ₂ Nm	S	i	Rn ₂ N						IEC 	
0.59	203	1.0	2280	5000	—	—	—	VF/W 30/63_2280	P56	BN56A4	129
0.89	155	1.4	1520	5000	—	—	—	VF/W 30/63_1520	P56	BN56A4	129
1.1	122	1.7	1200	5000	—	—	—	VF/W 30/63_1200	P56	BN56A4	129
1.5	115	1.8	900	5000	—	—	—	VF/W 30/63_900	P56	BN56A4	129
1.9	113	1.9	720	5000	—	—	—	VF/W 30/63_720	P56	BN56A4	129
2.5	85	1.1	540	3450	—	—	—	VF/VF 30/49_540	P56	BN56A4	124
2.8	50	1.0	500	5000	—	—	—	VFR 44_500	S44	BN44B4	116
3.2	73	1.3	420	3450	—	—	—	VF/VF 30/49_420	P56	BN56A4	124
4.0	54	1.0	350	5000	—	—	—	VFR 44_350	S44	BN44B4	116
4.3	53	1.8	315	3450	—	—	—	VF/VF 30/49_315	P56	BN56A4	124
4.5	59	1.0	300	2500	—	—	—	VFR 44_300	S44	BN44B4	116
5.8	50	1.2	230	2500	—	—	—	VFR 44_230	S44	BN44B4	116
7.7	42	1.5	175	2500	—	—	—	VFR 44_175	S44	BN44B4	116
9.6	36	1.4	140	2500	—	—	—	VFR 44_140	S44	BN44B4	116
13.4	29	1.8	100	2500	—	—	—	VFR 44_100	S44	BN44B4	116
19.1	22	1.8	70	2500	—	—	—	VFR 44_70	S44	BN44B4	116
19.3	14	1.1	70	1600	—	—	—	VF 30_70	P56	BN56A4	112
22.5	13	1.5	60	1600	—	—	—	VF 30_60	P56	BN56A4	112
34	10	0.9	40	600	—	—	—	VF 27_40	P27	BN27B4	111
34	10	1.9	40	1650	—	—	—	VF 30_40	P56	BN56A4	112
45	8	1.1	30	600	—	—	—	VF 27_30	P27	BN27B4	111
45	8	2.4	30	1340	—	—	—	VF 30_30	P56	BN56A4	112
68	6	1.5	20	600	—	—	—	VF 27_20	P27	BN27B4	111
68	6	2.9	20	1180	—	—	—	VF 30_20	P56	BN56A4	112
90	5	1.9	15	600	—	—	—	VF 27_15	P27	BN27B4	111
90	5	3.7	15	1080	—	—	—	VF 30_15	P56	BN56A4	112
135	4	2.6	10	595	—	—	—	VF 27_10	P27	BN27B4	111
135	3	4.7	10	950	—	—	—	VF 30_10	P56	BN56A4	112
193	2	3.6	7	533	—	—	—	VF 27_7	P27	BN27B4	111
193	2	6.4	7	840	—	—	—	VF 30_7	P56	BN56A4	112

0.09 kW

n ₂ min ⁻¹	M ₂ Nm	S	i	Rn ₂ N						IEC 	
0.31	574	1.8	2800	8000	—	—	—	VF/W 49/110_2800	P63	BN63A6	141
0.42	579	1.0	2116	7000	—	—	—	VF/W 44/86_2116	P63	BN63A6	137
0.43	505	2.1	2070	8000	—	—	—	VF/W 49/110_2070	P63	BN63A6	141
0.48	503	1.1	1840	7000	—	—	—	VF/W 44/86_1840	P63	BN63A6	137
0.53	485	2.2	1656	8000	—	—	—	VF/W 49/110_1656	P63	BN63A6	141
0.64	377	1.5	1380	7000	—	—	—	VF/W 44/86_1380	P63	BN63A6	137
0.65	369	2.8	1350	8000	—	—	—	VF/W 49/110_1350	P63	BN63A6	141









0.09 kW







n ₂ min ⁻¹	M ₂ Nm	S	i	R _{n2} N						IEC 	
0.73	363	1.1	1200	5750	—	—	—	VF/W 44/75_1200	P63	BN63A6	133
0.81	316	3.3	1080	8000	—	—	—	VF/W 49/110_1080	P63	BN63A6	141
0.89	232	0.9	1520	5000	—	—	—	VF/W 30/63_1520	P56	BN56B4	129
0.96	323	1.2	920	5750	—	—	—	VF/W 44/75_920	P63	BN63A6	133
0.96	332	1.7	920	7000	—	—	—	VF/W 44/86_920	P63	BN63A6	137
0.98	255	0.9	900	5000	—	—	—	VF/W 30/63_900	P63	BN63A6	129
1.1	183	1.1	1200	5000	—	—	—	VF/W 30/63_1200	P56	BN56B4	129
1.2	225	1.0	720	5000	—	—	—	VF/W 30/63_720	P63	BN63A6	129
1.3	267	1.5	700	5750	—	—	—	VF/W 44/75_700	P63	BN63A6	133
1.3	253	2.2	700	7000	—	—	—	VF/W 44/86_700	P63	BN63A6	137
1.5	172	1.2	900	5000	—	—	—	VF/W 30/63_900	P56	BN56B4	129
1.7	210	1.9	525	5750	—	—	—	VF/W 44/75_525	P63	BN63A6	133
1.7	200	2.8	525	7000	—	—	—	VF/W 44/86_525	P63	BN63A6	137
1.9	170	1.2	720	5000	—	—	—	VF/W 30/63_720	P56	BN56B4	129
2.2	164	2.4	400	5750	—	—	—	VF/W 44/75_400	P63	BN63A6	133
2.2	160	3.4	400	7000	—	—	—	VF/W 44/86_400	P63	BN63A6	137
2.4	145	1.4	570	5000	—	—	—	VF/W 30/63_570	P56	BN56B4	129
2.9	111	1.2	300	5000	—	—	—	WR 63_300	P63	BN63A6	128
2.9	120	1.7	300	6200	—	—	—	WR 75_300	P63	BN63A6	132
2.9	132	2.4	300	7000	—	—	—	WR 86_300	P63	BN63A6	136
3.0	117	1.8	450	5000	—	—	—	VF/W 30/63_450	P56	BN56B4	129
3.2	110	0.9	420	3450	—	—	—	VF/VF 30/49_420	P56	BN56B4	124
3.7	101	1.4	240	5000	—	—	—	WR 63_240	P63	BN63A6	128
3.7	105	2.1	240	6200	—	—	—	WR 75_240	P63	BN63A6	132
3.7	117	2.6	240	7000	—	—	—	WR 86_240	P63	BN63A6	136
4.2	84	0.9	210	3450	—	—	—	VFR 49_210	P63	BN63A6	122
4.3	80	1.2	315	3450	—	—	—	VF/VF 30/49_315	P56	BN56B4	124
4.3	84	2.5	315	5000	—	—	—	VF/W 30/63_315	P56	BN56B4	129
4.6	88	1.7	192	5000	—	—	—	WR 63_192	P63	BN63A6	128
4.9	79	0.9	180	3450	—	—	—	VFR 49_180	P63	BN63A6	122
4.9	90	3.1	180	6200	—	—	—	WR 75_180	P63	BN63A6	132
5.2	94	4.2	168	7000	—	—	—	WR 86_168	P63	BN63A6	136
5.5	62	1.0	245	2500	—	—	—	VF/VF 30/44_245	P56	BN56B4	118
6.5	66	1.2	135	3450	—	—	—	VFR 49_135	P63	BN63A6	122
6.5	71	2.5	135	5000	—	—	—	WR 63_135	P63	BN63A6	128
7.7	63	1.0	175	2900	—	—	—	VFR 44_175	S44	BN44C4	116
7.7	65	3.1	114	5000	—	—	—	WR 63_114	P63	BN63A6	128
8.1	58	1.4	108	3450	—	—	—	VFR 49_108	P63	BN63A6	122
8.8	41	1.3	100	3300	—	—	—	VF 49_100	P63	BN63A6	120
9.6	54	0.9	140	2900	—	—	—	VFR 44_140	S44	BN44C4	116
9.8	55	3.8	90	5000	—	—	—	WR 63_90	P63	BN63A6	128
10.5	48	1.9	84	3450	—	—	—	VFR 49_84	P63	BN63A6	122
11.0	37	1.6	80	3300	—	—	—	VF 49_80	P63	BN63A6	120
12.2	45	1.8	72	3450	—	—	—	VFR 49_72	P63	BN63A6	122
12.2	48	4.0	72	5000	—	—	—	WR 63_72	P63	BN63A6	128
12.6	35	1.1	70	2300	—	—	—	VF 44_70	P63	BN63A6	114
12.6	34	1.8	70	3300	—	—	—	VF 49_70	P63	BN63A6	120
13.4	43	1.2	100	2900	—	—	—	VFR 44_100	S44	BN44C4	116
14.7	32	1.4	60	2300	—	—	—	VF 44_60	P63	BN63A6	114
14.7	34	1.7	60	3300	—	—	—	VF 49_60	P63	BN63A6	120
16.3	36	2.2	54	3450	—	—	—	VFR 49_54	P63	BN63A6	122
19.1	33	1.2	70	2900	—	—	—	VFR 44_70	S44	BN44C4	116
19.1	27	1.8	46	2300	—	—	—	VF 44_46	P63	BN63A6	114
19.6	26	2.7	45	3300	—	—	—	VF 49_45	P63	BN63A6	120
21.0	30	2.8	42	3360	—	—	—	VFR 49_42	P63	BN63A6	122
22.0	22	0.9	40	1560	—	—	—	VF 30_40	P63	BN63A6	112
22.5	19	1.0	60	1600	—	—	—	VF 30_60	P56	BN56B4	112
24.4	22	3.4	36	3300	—	—	—	VF 49_36	P63	BN63A6	120
25.1	22	2.2	35	2300	—	—	—	VF 44_35	P63	BN63A6	114
29.3	18	1.2	30	1440	—	—	—	VF 30_30	P63	BN63A6	112
31	18	2.7	28	2300	—	—	—	VF 44_28	P63	BN63A6	114
34	15	1.2	40	1410	—	—	—	VF 30_40	P56	BN56B4	112
44	14	1.5	20	1230	—	—	—	VF 30_20	P63	BN63A6	112
44	14	3.1	20	2300	—	—	—	VF 44_20	P63	BN63A6	114
45	12	1.6	30	1290	—	—	—	VF 30_30	P56	BN56B4	112
59	11	1.8	15	1170	—	—	—	VF 30_15	P63	BN63A6	112
68	9	1.9	20	1140	—	—	—	VF 30_20	P56	BN56B4	112
69	9	1.0	20	600	—	—	—	VF 27_20	P27	BN27C4	111
88	8	2.3	10	1050	—	—	—	VF 30_10	P63	BN63A6	112
90	7	2.5	15	1050	—	—	—	VF 30_15	P56	BN56B4	112
92	7	1.3	15	600	—	—	—	VF 27_15	P27	BN27C4	111



0.09 kW







n ₂ min ⁻¹	M ₂ Nm	S	i	R _{n2} N						IEC 	
126	6	3.2	7	920	—	—	—	VF 30_7	P63	BN63A6	112
135	5	3.1	10	920	—	—	—	VF 30_10	P56	BN56B4	112
138	5	1.7	10	565	—	—	—	VF 27_10	P27	BN27C4	111
193	4	4.3	7	820	—	—	—	VF 30_7	P56	BN56B4	112
197	4	2.5	7	510	—	—	—	VF 27_7	P27	BN27C4	111

0.12 kW







n ₂ min ⁻¹	M ₂ Nm	S	i	R _{n2} N						IEC 	
0.31	775	1.4	2800	8000	—	—	—	VF/W 49/110_2800	P63	BN63B6	141
0.47	588	1.7	2800	8000	—	—	—	VF/W 49/110_2800	P63	BN63A4	141
0.53	654	1.6	1656	8000	—	—	—	VF/W 49/110_1656	P63	BN63B6	141
0.62	518	1.0	2116	7000	—	—	—	VF/W 44/86_2116	P63	BN63A4	137
0.63	507	2.0	2070	8000	—	—	—	VF/W 49/110_2070	P63	BN63A4	141
0.71	483	1.0	1840	7000	—	—	—	VF/W 44/86_1840	P63	BN63A4	137
0.79	435	2.3	1656	8000	—	—	—	VF/W 49/110_1656	P63	BN63A4	141
0.95	386	1.3	1380	7000	—	—	—	VF/W 44/86_1380	P63	BN63A4	137
0.97	354	2.8	1350	8000	—	—	—	VF/W 49/110_1350	P63	BN63A4	141
1.2	293	3.4	1080	8000	—	—	—	VF/W 49/110_1080	P63	BN63A4	141
1.4	322	1.1	920	5750	—	—	—	VF/W 44/75_920	P63	BN63A4	133
1.4	322	1.6	920	7000	—	—	—	VF/W 44/86_920	P63	BN63A4	137
1.5	236	0.9	900	5000	—	—	—	VF/W 30/63_900	P63	BN63A4	129
1.8	233	0.9	720	5000	—	—	—	VF/W 30/63_720	P63	BN63A4	129
1.9	257	1.4	700	5750	—	—	—	VF/W 44/75_700	P63	BN63A4	133
1.9	239	2.1	700	7000	—	—	—	VF/W 44/86_700	P63	BN63A4	137
2.3	199	1.1	570	5000	—	—	—	VF/W 30/63_570	P63	BN63A4	129
2.5	202	1.8	525	5750	—	—	—	VF/W 44/75_525	P63	BN63A4	133
2.5	193	2.6	525	7000	—	—	—	VF/W 44/86_525	P63	BN63A4	137
2.9	150	0.9	300	5000	—	—	—	WR 63_300	P63	BN63B6	128
2.9	162	1.2	300	6200	—	—	—	WR 75_300	P63	BN63B6	132
2.9	178	1.7	300	7000	—	—	—	WR 86_300	P63	BN63B6	136
2.9	161	1.3	450	5000	—	—	—	VF/W 30/63_450	P63	BN63A4	129
3.3	161	2.3	400	5750	—	—	—	VF/W 44/75_400	P63	BN63A4	133
3.3	143	3.5	400	7000	—	—	—	VF/W 44/86_400	P63	BN63A4	137
3.6	136	1.0	240	5000	—	—	—	WR 63_240	P63	BN63B6	128
3.6	142	1.5	240	6200	—	—	—	WR 75_240	P63	BN63B6	132
3.6	142	1.6	240	5000	—	—	—	VF/W 30/63_240	P63	BN63B6	129
3.6	158	2.0	240	7000	—	—	—	WR 86_240	P63	BN63B6	136
4.2	110	0.9	315	3450	—	—	—	VF/VF 30/49_315	P63	BN63A4	124
4.2	116	1.8	315	5000	—	—	—	VF/W 30/63_315	P63	BN63A4	129
4.4	108	1.2	300	5000	—	—	—	WR 63_300	P63	BN63A4	128
4.4	115	1.6	300	6200	—	—	—	WR 75_300	P63	BN63A4	132
4.4	129	2.1	300	7000	—	—	—	WR 86_300	P63	BN63A4	136
4.4	134	2.8	300	5750	—	—	—	VF/W 44/75_300	P63	BN63A4	133
4.8	121	2.3	180	6200	—	—	—	WR 75_180	P63	BN63B6	132
5.2	126	3.1	168	7000	—	—	—	WR 86_168	P63	BN63B6	136
5.2	125	3.0	250	5750	—	—	—	VF/W 44/75_250	P63	BN63A4	133
5.5	94	1.0	240	3450	—	—	—	VF/VF 30/49_240	P63	BN63A4	124
5.5	97	1.4	240	5000	—	—	—	WR 63_240	P63	BN63A4	128
5.5	103	2.1	240	6200	—	—	—	WR 75_240	P63	BN63A4	132
5.5	99	2.1	240	5000	—	—	—	VF/W 30/63_240	P63	BN63A4	129
5.5	111	2.7	240	7000	—	—	—	WR 86_240	P63	BN63A4	136
5.8	109	2.9	150	6200	—	—	—	WR 75_150	P63	BN63B6	132
6.4	89	0.9	135	3300	—	—	—	VFR 49_135	P63	BN63B6	122
6.4	96	1.9	135	5000	—	—	—	WR 63_135	P63	BN63B6	128
6.8	86	1.8	192	5000	—	—	—	WR 63_192	P63	BN63A4	128
7.3	76	0.9	180	3300	—	—	—	VFR 49_180	P63	BN63A4	122
7.3	87	2.7	180	6200	—	—	—	WR 75_180	P63	BN63A4	132
8.7	55	0.9	100	3300	—	—	—	VF 49_100	P63	BN63B6	120
9.7	64	1.4	135	3450	—	—	—	VFR 49_135	P63	BN63A4	122
9.7	68	2.5	135	5000	—	—	—	WR 63_135	P63	BN63A4	128
10.9	50	1.2	80	3300	—	—	—	VF 49_80	P63	BN63B6	120
11.5	61	3.0	114	5000	—	—	—	WR 63_114	P63	BN63A4	128
12.1	55	1.5	108	3450	—	—	—	VFR 49_108	P63	BN63A4	122
13.1	41	1.2	100	3150	—	—	—	VF 49_100	P63	BN63A4	120
14.5	43	1.1	60	2300	—	—	—	VF 44_60	P63	BN63B6	114



0.12 kW







n ₂ min ⁻¹	M ₂ Nm	S	i	R _{n2} N						IEC 	
15.3	53	3.6	57	5000	—	—	—	WR 63_57	P63	BN63B6	128
15.6	46	1.9	84	3450	—	—	—	VFR 49_84	P63	BN63A4	122
16.4	36	1.5	80	3150	—	—	—	VF 49_80	P63	BN63A4	120
18.2	42	1.8	72	3430	—	—	—	VFR 49_72	P63	BN63A4	122
18.7	34	0.9	70	3300	—	—	—	VF 44_70	P63	BN63A4	114
18.7	33	1.7	70	3150	—	—	—	VF 49_70	P63	BN63A4	120
21.8	30	1.3	60	2300	—	—	—	VF 44_60	P63	BN63A4	114
21.8	30	1.9	60	3150	—	—	—	VF 49_60	P63	BN63A4	120
24.3	34	2.2	54	3140	—	—	—	VFR 49_54	P63	BN63A4	122
28.5	25	1.5	46	2300	—	—	—	VF 44_46	P63	BN63A4	114
29.0	24	0.9	30	1360	—	—	—	VF 30_30	P63	BN63B6	112
29.1	25	2.6	45	3040	—	—	—	VF 49_45	P63	BN63A4	120
31	27	2.9	42	2920	—	—	—	VFR 49_42	P63	BN63A4	122
33	21	0.9	40	1360	—	—	—	VF 30_40	P63	BN63A4	112
36	21	3.3	36	2830	—	—	—	VF 49_36	P63	BN63A4	120
37	21	1.9	35	2300	—	—	—	VF 44_35	P63	BN63A4	114
44	17	1.2	30	1250	—	—	—	VF 30_30	P63	BN63A4	112
47	17	2.2	28	2300	—	—	—	VF 44_28	P63	BN63A4	114
58	15	1.4	15	1130	—	—	—	VF 30_15	P63	BN63B6	112
62	14	2.7	14	2150	—	—	—	VF 44_14	P63	BN63B6	114
66	13	1.4	20	1110	—	—	—	VF 30_20	P63	BN63A4	112
66	13	2.9	20	2100	—	—	—	VF 44_20	P63	BN63A4	114
87	10	1.8	15	1020	—	—	—	VF 30_15	P63	BN63A4	112
94	10	2.9	14	1870	—	—	—	VF 44_14	P63	BN63A4	114
124	8	2.4	7	900	—	—	—	VF 30_7	P63	BN63B6	112
131	7	2.3	10	900	—	—	—	VF 30_10	P63	BN63A4	112
138	6	1.1	20	560	—	—	—	VF 27_20	P27	BN27C2	111
138	7	2.2	20	840	—	—	—	VF 30_20	P56	BN56B2	112
183	5	1.4	15	520	—	—	—	VF 27_15	P27	BN27C2	111
187	5	3.1	7	810	—	—	—	VF 30_7	P63	BN63A4	112
275	4	2.0	10	460	—	—	—	VF 27_10	P27	BN27C2	111
275	4	3.4	10	740	—	—	—	VF 30_10	P56	BN56B2	112
393	3	2.8	7	410	—	—	—	VF 27_7	P27	BN27C2	111
393	3	4.7	7	660	—	—	—	VF 30_7	P56	BN56B2	112

0.18 kW

n ₂ min ⁻¹	M ₂ Nm	S	i	R _{n2} N						IEC 	
0.28	978	1.9	3200	13800	—	—	—	W/VF 63/130_3200	P71	BN71A6	146
0.28	1345	3.3	3200	19500	—	—	—	W/VF 86/185_3200	P71	BN71A6	162
0.31	1406	1.9	2944	16000	—	—	—	W/VF 86/150_2944	P71	BN71A6	154
0.35	1027	1.8	2560	13800	—	—	—	W/VF 63/130_2560	P71	BN71A6	146
0.35	1320	3.3	2560	19500	—	—	—	W/VF 86/185_2560	P71	BN71A6	162
0.47	875	1.1	2800	8000	—	—	—	VF/W 49/110_2800	P63	BN63B4	141
0.49	1265	2.1	1840	16000	—	—	—	W/VF 86/150_1840	P71	BN71A6	154
0.50	894	2.1	1800	13800	—	—	—	W/VF 63/130_1800	P71	BN71A6	146
0.54	949	1.1	1656	8000	—	—	—	VF/W 49/110_1656	P71	BN71A6	141
0.59	871	2.1	1520	13800	—	—	—	W/VF 63/130_1520	P71	BN71A6	146
0.64	755	1.3	2070	8000	—	—	—	VF/W 49/110_2070	P63	BN63B4	141
0.65	1054	2.6	1380	16000	—	—	—	W/VF 86/150_1380	P71	BN71A6	154
0.75	733	2.5	1200	13800	—	—	—	W/VF 63/130_1200	P71	BN71A6	146
0.80	647	1.5	1656	8000	—	—	—	VF/W 49/110_1656	P63	BN63B4	141
0.94	642	2.9	960	13800	—	—	—	W/VF 63/130_960	P71	BN71A6	146
0.98	527	1.9	1350	8000	—	—	—	VF/W 49/110_1350	P63	BN63B4	141
0.98	756	3.6	920	16000	—	—	—	W/VF 86/150_920	P71	BN71A6	154
1.2	537	3.4	760	13800	—	—	—	W/VF 63/130_760	P71	BN71A6	146
1.2	436	2.3	1080	8000	—	—	—	VF/W 49/110_1080	P63	BN63B4	141
1.4	479	1.0	920	7000	—	—	—	VF/W 44/86_920	P63	BN63B4	137
1.7	391	1.4	525	7000	—	—	—	VF/W 44/86_525	P71	BN71A6	137
1.8	375	2.7	720	8000	—	—	—	VF/W 49/110_720	P63	BN63B4	141
1.9	356	1.4	700	7000	—	—	—	VF/W 44/86_700	P63	BN63B4	137
2.3	321	1.2	400	5750	—	—	—	VF/W 44/75_400	P71	BN71A6	133
2.3	313	1.8	400	7000	—	—	—	VF/W 44/86_400	P71	BN71A6	137
2.3	344	3.1	400	8000	—	—	—	VF/W 49/110_400	P71	BN71A6	141
2.4	288	3.5	540	8000	—	—	—	VF/W 49/110_540	P63	BN63B4	141









0.18 kW







n ₂ min-1	M ₂ Nm	S	i	R _{n2} N						IEC 		
2.5	301	1.2	525	5750	—	—	—	VF/W 44/75_525	P63	BN63B4	133	
2.5	287	1.7	525	7000	—	—	—	VF/W 44/86_525	P63	BN63B4	137	
3.0	258	1.2	300	7000	—	—	—	WR 86_300	P71	BN71A6	136	
3.0	264	1.5	300	5750	—	—	—	VF/W 44/75_300	P71	BN71A6	133	
3.0	275	2.1	300	8000	—	—	—	WR 110_300	P71	BN71A6	140	
3.0	241	2.3	300	7000	—	—	—	VF/W 44/86_300	P71	BN71A6	137	
3.0	269	3.9	300	8000	—	—	—	VF/W 49/110_300	P71	BN71A6	141	
3.3	240	1.5	400	5750	—	—	—	VF/W 44/75_400	P63	BN63B4	133	
3.3	214	2.3	400	7000	—	—	—	VF/W 44/86_400	P63	BN63B4	137	
3.8	206	1.1	240	6200	—	—	—	WR 75_240	P71	BN71A6	132	
3.8	229	1.4	240	7000	—	—	—	WR 86_240	P71	BN71A6	136	
3.8	243	2.4	240	8000	—	—	—	WR 110_240	P71	BN71A6	140	
3.9	233	2.4	230	7000	—	—	—	VF/W 44/86_230	P71	BN71A6	137	
4.2	172	1.2	315	5000	—	—	—	VF/W 30/63_315	P63	BN63B4	129	
4.4	172	1.0	300	6200	—	—	—	WR 75_300	P63	BN63B4	132	
4.4	191	1.4	300	7000	—	—	—	WR 86_300	P63	BN63B4	136	
4.4	199	1.9	300	5750	—	—	—	VF/W 44/75_300	P63	BN63B4	133	
4.4	176	2.8	300	7000	—	—	—	VF/W 44/86_300	P63	BN63B4	137	
4.7	202	1.9	192	7000	—	—	—	WR 86_192	P71	BN71A6	136	
5.0	175	1.6	180	6200	—	—	—	WR 75_180	P71	BN71A6	132	
5.3	186	2.0	250	5750	—	—	—	VF/W 44/75_250	P63	BN63B4	133	
5.4	183	2.1	168	7000	—	—	—	WR 86_168	P71	BN71A6	136	
5.5	144	0.9	240	5000	—	—	—	WR 63_240	P63	BN63B4	128	
5.5	153	1.4	240	6200	—	—	—	WR 75_240	P63	BN63B4	132	
5.5	147	1.4	240	5000	—	—	—	VF/W 30/63_240	P63	BN63B4	129	
5.5	166	1.8	240	7000	—	—	—	WR 86_240	P63	BN63B4	136	
5.7	162	3.1	230	7000	—	—	—	VF/W 44/86_230	P63	BN63B4	137	
6.0	158	2.0	150	6200	—	—	—	WR 75_150	P71	BN71A6	132	
6.5	161	2.7	138	7000	—	—	—	WR 86_138	P71	BN71A6	136	
6.9	128	1.2	192	5000	—	—	—	WR 63_192	P63	BN63B4	128	
6.9	145	2.3	192	7000	—	—	—	WR 86_192	P63	BN63B4	136	
7.3	129	1.8	180	6200	—	—	—	WR 75_180	P63	BN63B4	132	
7.5	138	2.4	120	6200	—	—	—	WR 75_120	P71	BN71A6	132	
7.9	131	2.7	168	7000	—	—	—	WR 86_168	P63	BN63B4	136	
7.9	126	1.6	114	5000	—	—	—	WR 63_114	P71	BN71A6	128	
8.8	113	2.3	150	6200	—	—	—	WR 75_150	P63	BN63B4	132	
9.0	88	1.4	100	5000	W 63_100	S1	M1SC6	126	W 63_100	P71	BN71A6	127
9.0	96	1.7	100	6200	W 75_100	S1	M1SC6	130	W 75_100	P71	BN71A6	131
9.0	105	2.4	100	7000	W 86_100	S1	M1SC6	134	W 86_100	P71	BN71A6	135
9.8	102	1.7	135	5000	—	—	—	WR 63_135	P63	BN63B4	128	
10.0	107	1.9	90	5000	—	—	—	WR 63_90	P71	BN71A6	128	
11.0	98	3.1	120	6200	—	—	—	WR 75_120	P63	BN63B4	132	
11.3	79	1.6	80	5000	W 63_80	S1	M1SC6	126	W 63_80	P71	BN71A6	127
11.3	83	2.4	80	6200	W 75_80	S1	M1SC6	130	W 75_80	P71	BN71A6	131
11.3	90	3.1	80	7000	W 86_80	S1	M1SC6	134	W 86_80	P71	BN71A6	135
11.6	91	2.0	114	5000	—	—	—	WR 63_114	P63	BN63B4	128	
12.0	100	3.3	75	6200	—	—	—	WR 75_75	P71	BN71A6	132	
12.2	82	1.0	108	3450	—	—	—	VFR 49_108	P63	BN63B4	122	
14.7	75	2.5	90	5000	—	—	—	WR 63_90	P63	BN63B4	128	
15.0	61	1.1	60	3000	—	—	—	VF 49_60	P71	BN71A6	120	
15.0	60	1.1	180	3300	—	—	—	VFR 49_180	P63	BN63A2	122	
15.7	68	1.3	84	3420	—	—	—	VFR 49_84	P63	BN63B4	122	
16.5	54	1.0	80	3150	—	—	—	VF 49_80	P63	BN63B4	120	
18.3	63	1.2	72	3270	—	—	—	VFR 49_72	P63	BN63B4	122	
18.3	66	2.8	72	5000	—	—	—	WR 63_72	P63	BN63B4	128	
18.9	49	1.1	70	3150	—	—	—	VF 49_70	P63	BN63B4	120	
20.0	50	1.4	135	3280	—	—	—	VFR 49_135	P63	BN63A2	122	
20.0	54	2.9	45	5000	W63_45	S1	M1SC6	126	W 63_45	P71	BN71A6	127
22.0	45	0.9	60	2300	—	—	—	VF 44_60	P63	BN63B4	114	
22.0	45	1.3	60	3150	—	—	—	VF 49_60	P63	BN63B4	120	
23.2	54	3.3	57	4910	—	—	—	WR 63_57	P63	BN63B4	128	
24.4	50	1.5	54	3010	—	—	—	VFR 49_54	P63	BN63B4	122	
28.7	38	1.0	46	2500	—	—	—	VF 44_46	P63	BN63B4	114	
29.3	37	1.8	45	2300	—	—	—	VF 49_45	P63	BN63B4	120	
31	40	1.9	42	2810	—	—	—	VFR 49_42	P63	BN63B4	122	
32	36	1.4	28	2290	—	—	—	VF 44_28	P71	BN71A6	114	
37	31	2.2	36	2760	—	—	—	VF 49_36	P63	BN63B4	120	
38	31	1.3	35	2430	—	—	—	VF 44_35	P63	BN63B4	114	
47	26	1.5	28	2270	—	—	—	VF 44_28	P63	BN63B4	114	



0.18 kW







n ₂ min ⁻¹	M ₂ Nm	S	i	Rn ₂ N						IEC 	
47	26	2.9	28	2560	—	—	—	VF 49_28	P63	BN63B4	120
55	23	2.7	24	2430	—	—	—	VF 49_24	P63	BN63B4	120
66	19	0.9	20	1040	—	—	—	VF 30_20	P63	BN63B4	112
66	20	1.9	20	2040	—	—	—	VF 44_20	P63	BN63B4	114
73	18	3.2	18	2230	—	—	—	VF 49_18	P63	BN63B4	120
77	16	1.8	35	1970	—	—	—	VF 44_35	P63	BN63A2	114
88	15	1.2	15	960	—	—	—	VF 30_15	P63	BN63B4	112
94	15	2.0	14	1830	—	—	—	VF 44_14	P63	BN63B4	114
132	11	1.5	10	860	—	—	—	VF 30_10	P63	BN63B4	112
132	11	2.7	10	1640	—	—	—	VF 44_10	P63	BN63B4	114
189	8	2.1	7	770	—	—	—	VF 30_7	P63	BN63B4	112
193	7	2.9	14	1470	—	—	—	VF 44_14	P63	BN63A2	114
270	5	2.2	10	710	—	—	—	VF 30_10	P63	BN63A2	112
386	4	3.1	7	640	—	—	—	VF 30_7	P63	BN63A2	112

0.25 kW

n ₂ min ⁻¹	M ₂ Nm	S	i	Rn ₂ N						IEC 	
0.28	1358	1.4	3200	13800	—	—	—	W/VF 63/130_3200	P71	BN71B6	146
0.28	1868	2.4	3200	19500	—	—	—	W/VF 86/185_3200	P71	BN71B6	162
0.31	1952	1.4	2944	16000	—	—	—	W/VF 86/150_2944	P71	BN71B6	154
0.43	945	1.9	3200	13800	—	—	—	W/VF 63/130_3200	P71	BN71A4	146
0.43	1334	3.1	3200	19500	—	—	—	W/VF 86/185_3200	P71	BN71A4	162
0.47	1380	1.9	2944	16000	—	—	—	W/VF 86/150_2944	P71	BN71A4	154
0.49	1562	2.8	1840	19500	—	—	—	W/VF 86/185_1840	P71	BN71B6	162
0.54	1022	1.8	2560	13800	—	—	—	W/VF 63/130_2560	P71	BN71A4	146
0.54	1289	3.3	2560	19500	—	—	—	W/VF 86/185_2560	P71	BN71A4	162
0.65	1464	1.8	1380	16000	—	—	—	W/VF 86/150_1380	P71	BN71B6	154
0.66	1006	1.0	2070	8000	—	—	—	VF/W 49/110_2070	P71	BN71A4	141
0.75	1214	2.1	1840	16000	—	—	—	W/VF 86/150_1840	P71	BN71A4	154
0.75	1019	1.8	1200	13800	—	—	—	W/VF 63/130_1200	P71	BN71B6	146
0.76	875	2.1	1800	13800	—	—	—	W/VF 63/130_1800	P71	BN71A4	146
0.83	863	1.2	1656	8000	—	—	—	VF/W 49/110_1656	P71	BN71A4	141
0.90	845	2.1	1520	13800	—	—	—	W/VF 63/130_1520	P71	BN71A4	146
0.98	1049	2.6	920	16000	—	—	—	W/VF 86/150_920	P71	BN71B6	154
1.0	1006	2.6	1380	16000	—	—	—	W/VF 86/150_1380	P71	BN71A4	154
1.0	703	1.4	1350	8000	—	—	—	VF/W 49/110_1350	P71	BN71A4	141
1.1	708	2.5	1200	13800	—	—	—	W/VF 63/130_1200	P71	BN71A4	146
1.2	746	2.5	760	13800	—	—	—	W/VF 63/130_760	P71	BN71B6	146
1.3	581	1.7	1080	8000	—	—	—	VF/W 49/110_1080	P71	BN71A4	141
1.3	860	3.1	690	16000	—	—	—	W/VF 86/150_690	P71	BN71B6	154
1.4	617	2.9	960	13800	—	—	—	W/VF 63/130_960	P71	BN71A4	146
1.7	544	1.9	540	8000	—	—	—	VF/W 49/110_540	P71	BN71B6	141
1.7	543	1.0	525	7000	—	—	—	VF/W 44/86_525	P71	BN71B6	137
1.8	515	3.5	760	13800	—	—	—	W/VF 63/130_760	P71	BN71A4	146
1.9	500	2.0	720	8000	—	—	—	VF/W 49/110_720	P71	BN71A4	141
2.0	474	1.1	700	7000	—	—	—	VF/W 44/86_700	P71	BN71A4	137
2.5	384	2.6	540	8000	—	—	—	VF/W 49/110_540	P71	BN71A4	141
2.6	383	1.3	525	7000	—	—	—	VF/W 44/86_525	P71	BN71A4	137
3.0	366	1.1	300	5750	—	—	—	VF/W 44/75_300	P71	BN71B6	133
3.0	382	1.5	300	8000	—	—	—	WR 110_300	P71	BN71B6	140
3.0	374	2.8	300	8000	—	—	—	VF/W 49/110_300	P71	BN71B6	141
3.4	319	1.2	400	5750	—	—	—	VF/W 44/75_400	P71	BN71A4	133
3.4	285	1.8	400	7000	—	—	—	VF/W 44/86_400	P71	BN71A4	137
3.4	313	3.2	400	8000	—	—	—	VF/W 49/110_400	P71	BN71A4	141
3.8	318	1.0	240	7000	—	—	—	WR 86_240	P71	BN71B6	136
3.8	337	1.7	240	8000	—	—	—	WR 110_240	P71	BN71B6	140
3.9	323	1.7	230	7000	—	—	—	VF/W 44/86_230	P71	BN71B6	137
3.9	311	3.4	230	8000	—	—	—	VF/W 49/110_230	P71	BN71B6	141
4.6	255	1.1	300	7000	—	—	—	WR 86_300	P71	BN71A4	136
4.6	266	1.4	300	5750	—	—	—	VF/W 44/75_300	P71	BN71A4	133
4.6	266	2.1	300	8000	—	—	—	WR 110_300	P71	BN71A4	140
4.6	234	2.1	300	7000	—	—	—	VF/W 44/86_300	P71	BN71A4	137
4.7	280	1.4	192	7000	—	—	—	WR 86_192	P71	BN71B6	136



0.25 kW

n ₂ min-1	M ₂ Nm	S	i	R _{n2} N						IEC 		
5.5	247	1.5	250	5750	—	—	—	—	VF/W 44/75_250	P71	BN71A4	133
5.7	204	1.1	240	6200	—	—	—	—	WR 75_240	P71	BN71A4	132
5.7	221	1.4	240	7000	—	—	—	—	WR 86_240	P71	BN71A4	136
5.7	233	2.4	240	8000	—	—	—	—	WR 110_240	P71	BN71A4	140
6.0	216	2.3	230	7000	—	—	—	—	VF/W 44/86_230	P71	BN71A4	137
6.0	219	1.4	150	6200	—	—	—	—	WR 75_150	P71	BN71B6	132
6.7	193	0.9	135	5000	—	—	—	—	WR 63_135	P71	BN71B6	128
7.2	193	1.7	192	7000	—	—	—	—	WR 86_192	P71	BN71A4	136
7.2	200	3.1	192	8000	—	—	—	—	WR 110_192	P71	BN71A4	140
7.6	172	1.4	180	6200	—	—	—	—	WR 75_180	P71	BN71A4	132
7.9	175	1.1	114	5000	—	—	—	—	WR 63_114	P71	BN71B6	128
8.2	175	2.0	168	7000	—	—	—	—	WR 86_168	P71	BN71A4	136
9.0	122	1.0	100	5000	W 63_100	S1	M1SD6	126	—	—	—	—
9.0	133	1.2	100	6200	W 75_100	S1	M1SD6	130	W 75_100	P71	BN71B6	131
9.0	146	1.7	100	7000	W 86_100	S1	M1SD6	134	W 86_100	P71	BN71B6	135
9.2	151	1.7	150	6200	—	—	—	—	WR 75_150	P71	BN71A4	132
10.0	151	2.7	138	7000	—	—	—	—	WR 86_138	P71	BN71A4	136
10.0	160	2.3	90	6200	—	—	—	—	WR 75_90	P71	BN71B6	132
10.2	136	1.3	135	5000	—	—	—	—	WR 63_135	P71	BN71A4	128
11.3	110	1.1	80	5000	W 63_80	S1	M1SD6	126	—	—	—	—
11.3	115	1.7	80	6200	W 75_80	S1	M1SD6	130	W 75_80	P71	BN71B6	131
11.3	125	2.2	80	7000	W 86_80	S1	M1SD6	134	W 86_80	P71	BN71B6	135
11.5	131	2.3	120	6200	—	—	—	—	WR 75_120	P71	BN71A4	132
11.5	138	2.8	120	7000	—	—	—	—	WR 86_120	P71	BN71A4	136
12.1	121	1.5	114	5000	—	—	—	—	WR 63_114	P71	BN71A4	128
13.8	89	1.3	100	5000	—	—	—	—	W 63_100	P71	BN71A4	126
13.8	96	1.6	100	6200	—	—	—	—	W 75_100	P71	BN71A4	130
13.8	102	2.2	100	7000	—	—	—	—	W 86_100	P71	BN71A4	134
15.3	100	1.9	90	5000	—	—	—	—	WR 63_90	P71	BN71A4	128
15.3	108	3.0	90	6200	—	—	—	—	WR 75_90	P71	BN71A4	132
17.2	78	1.5	80	5000	—	—	—	—	W 63_80	P71	BN71A4	126
17.2	82	2.2	80	6200	—	—	—	—	W 75_80	P71	BN71A4	130
17.2	89	2.9	80	7000	—	—	—	—	W 86_80	P71	BN71A4	134
18.3	95	3.1	75	6200	—	—	—	—	WR 75_75	P71	BN71A4	132
19.1	88	2.1	72	5000	—	—	—	—	WR 63_72	P71	BN71A4	128
20.0	70	1.0	45	3150	—	—	—	—	—	—	—	—
21.5	68	1.8	64	5000	—	—	—	—	W 63_64	P71	BN71A4	126
22.0	63	0.9	60	3150	—	—	—	—	—	—	—	—
22.9	68	3.0	60	6200	—	—	—	—	W 75_60	P71	BN71A4	130
24.1	72	2.5	57	4780	—	—	—	—	WR 63_57	P71	BN71A4	128
29.3	51	1.3	45	2850	—	—	—	—	—	—	—	—
31	52	2.8	45	4550	—	—	—	—	W 63_45	P71	BN71A4	126
31	59	3.0	45	4460	—	—	—	—	WR 63_45	P71	BN71A4	128
32	50	1.0	28	2300	—	—	—	—	VF 44_28	P71	BN71B6	114
36	46	3.4	38	4320	—	—	—	—	W 63_38	P71	BN71A4	126
37	44	1.6	36	2670	—	—	—	—	VF 49_36	P71	BN71A4	120
38	43	0.9	35	2300	—	—	—	—	VF 44_35	P71	BN71A4	114
38	49	3.3	36	4160	—	—	—	—	WR 63_36	P71	BN71A4	128
45	39	1.1	20	2190	—	—	—	—	VF 44_20	P71	BN71B6	114
47	36	1.1	28	2190	—	—	—	—	VF 44_28	P71	BN71A4	114
47	36	2.1	28	2480	—	—	—	—	VF 49_28	P71	BN71A4	120
55	33	1.9	24	2360	—	—	—	—	VF 49_24	P71	BN71A4	120
64	29	1.3	14	1980	—	—	—	—	VF 44_14	P71	BN71B6	114
64	29	2.5	14	2260	—	—	—	—	VF 49_14	P71	BN71B6	120
66	28	1.4	20	1970	—	—	—	—	VF 44_20	P71	BN71A4	114
73	25	2.3	18	2170	—	—	—	—	VF 49_18	P71	BN71A4	120
77	23	1.3	35	1930	—	—	—	—	VF 44_35	P63	BN63B2	114
90	22	1.8	10	1780	—	—	—	—	VF 44_10	P71	BN71B6	114
90	22	2.9	10	2040	—	—	—	—	VF 49_10	P71	BN71B6	120
94	21	1.4	14	1770	—	—	—	—	VF 44_14	P71	BN71A4	114
94	21	3.2	14	2010	—	—	—	—	VF 49_14	P71	BN71A4	120
113	17	2.8	24	1930	—	—	—	—	VF 49_24	P63	BN63B2	120
129	16	2.5	7	1590	—	—	—	—	VF 44_7	P71	BN71B6	114
132	15	1.9	10	1590	—	—	—	—	VF 44_10	P71	BN71A4	114
135	14	1.0	20	840	—	—	—	—	VF 30_20	P63	BN63B2	112
180	11	1.3	15	780	—	—	—	—	VF 30_15	P63	BN63B2	112
189	11	2.7	7	1420	—	—	—	—	VF 44_7	P71	BN71A4	114
270	8	1.6	10	690	—	—	—	—	VF 30_10	P63	BN63B2	112

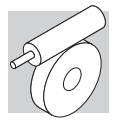

0.25 kW







n ₂ min ⁻¹	M ₂ Nm	S	i	R _{n2} N						IEC	
270	8	2.9	10	1300	—	—	—	VF 44_10	P63	BN63B2	114
386	5	2.2	7	620	—	—	—	VF 30_7	P63	BN63B2	112

0.37 kW

n ₂ min ⁻¹	M ₂ Nm	S	i	R _{n2} N						IEC	
0.28	2734	1.6	3200	19500	—	—	—	W/VF 86/185_3200	P80	BN80A6	162
0.31	2858	0.9	2944	16000	—	—	—	W/VF 86/150_2944	P80	BN80A6	154
0.36	2684	1.6	2560	19500	—	—	—	W/VF 86/185_2560	P80	BN80A6	162
0.43	1403	1.3	3200	13800	—	—	—	W/VF 63/130_3200	P71	BN71B4	146
0.43	1981	2.1	3200	19500	—	—	—	W/VF 86/185_3200	P71	BN71B4	162
0.47	2050	1.3	2944	16000	—	—	—	W/VF 86/150_2944	P71	BN71B4	154
0.54	1519	1.2	2560	13800	—	—	—	W/VF 63/130_2560	P71	BN71B4	146
0.54	1915	2.2	2560	19500	—	—	—	W/VF 86/185_2560	P71	BN71B4	162
0.60	1771	1.0	1520	13800	—	—	—	W/VF 63/130_1520	P80	BN80A6	146
0.66	2143	1.3	1380	16000	—	—	—	W/VF 86/150_1380	P80	BN80A6	154
0.74	1803	1.4	1840	16000	—	—	—	W/VF 86/150_1840	P71	BN71B4	154
0.74	1614	2.6	1840	19500	—	—	—	W/VF 86/185_1840	P71	BN71B4	162
0.76	1300	1.4	1800	13800	—	—	—	W/VF 63/130_1800	P71	BN71B4	146
0.86	1444	2.9	1600	19500	—	—	—	W/VF 86/185_1600	P71	BN71B4	162
0.90	1255	1.4	1520	13800	—	—	—	W/VF 63/130_1520	P71	BN71B4	146
0.99	1357	3.2	920	19500	—	—	—	W/VF 86/185_920	P80	BN80A6	162
0.99	1495	1.7	1380	16000	—	—	—	W/VF 86/150_1380	P71	BN71B4	154
1.0	1045	1.0	1350	8000	—	—	—	VF/W 49/110_1350	P71	BN71B4	141
1.1	1052	1.7	1200	13800	—	—	—	W/VF 63/130_1200	P71	BN71B4	146
1.3	864	1.2	1080	8000	—	—	—	VF/W 49/110_1080	P71	BN71B4	141
1.3	1259	2.1	690	16000	—	—	—	W/VF 86/150_690	P80	BN80A6	154
1.4	916	2.0	960	13800	—	—	—	W/VF 63/130_960	P71	BN71B4	146
1.5	1068	2.4	920	16000	—	—	—	W/VF 86/150_920	P71	BN71B4	154
1.7	797	1.3	540	8000	—	—	—	VF/W 49/110_540	P80	BN80A6	141
1.7	1068	2.5	529	16000	—	—	—	W/VF 86/150_529	P80	BN80A6	154
1.8	764	2.4	760	13800	—	—	—	W/VF 63/130_760	P71	BN71B4	146
1.9	743	1.3	720	8000	—	—	—	VF/W 49/110_720	P71	BN71B4	141
2.0	890	2.9	690	16000	—	—	—	W/VF 86/150_690	P71	BN71B4	154
2.3	619	2.9	600	13800	—	—	—	W/VF 63/130_600	P71	BN71B4	146
2.5	571	1.8	540	8000	—	—	—	VF/W 49/110_540	P71	BN71B4	141
2.6	750	3.5	529	16000	—	—	—	W/VF 86/150_529	P71	BN71B4	154
3.0	559	1.0	300	8000	—	—	—	WR 110_300	P80	BN80A6	140
3.0	571	1.8	300	13800	—	—	—	VFR 130_300	P80	BN80A6	144
3.0	547	1.9	300	8000	—	—	—	VF/W 49/110_300	P80	BN80A6	141
3.4	423	1.2	400	7000	—	—	—	VF/W 44/86_400	P71	BN71B4	137
3.4	464	2.2	400	8000	—	—	—	VF/W 49/110_400	P71	BN71B4	141
3.8	494	1.2	240	8000	—	—	—	WR 110_240	P80	BN80A6	140
3.8	503	2.4	240	13800	—	—	—	VFR 130_240	P80	BN80A6	144
4.0	455	2.3	230	8000	—	—	—	VF/W 49/110_230	P80	BN80A6	141
4.6	395	1.4	300	8000	—	—	—	WR 110_300	P71	BN71B4	140
4.6	348	1.4	300	7000	—	—	—	VF/W 44/86_300	P71	BN71B4	137
4.6	371	2.7	300	8000	—	—	—	VF/W 49/110_300	P71	BN71B4	141
4.7	410	1.0	192	7000	—	—	—	WR 86_192	P80	BN80A6	136
4.7	425	1.6	192	8000	—	—	—	WR 110_192	P80	BN80A6	140
4.7	432	3.0	192	13800	—	—	—	VFR 130_192	P80	BN80A6	144
5.4	372	1.0	168	7000	—	—	—	WR 86_168	P80	BN80A6	136
5.4	391	2.0	168	8000	—	—	—	WR 110_168	P80	BN80A6	140
5.4	391	3.4	168	13800	—	—	—	VFR 130_168	P80	BN80A6	144
5.7	328	0.9	240	7000	—	—	—	WR 86_240	P71	BN71B4	136
5.7	347	1.6	240	8000	—	—	—	WR 110_240	P71	BN71B4	140
6.0	320	1.6	230	7000	—	—	—	VF/W 44/86_230	P71	BN71B4	137
6.0	308	3.2	230	8000	—	—	—	VF/W 49/110_230	P71	BN71B4	141
6.1	320	1.0	150	6200	—	—	—	WR 75_150	P80	BN80A6	132
6.6	327	1.3	138	7000	—	—	—	WR 86_138	P80	BN80A6	136
6.6	338	2.4	138	8000	—	—	—	WR 110_138	P80	BN80A6	140









0.37 kW







n ₂ min-1	M ₂ Nm	S	i	R _{n2} N						IEC 		
7.1	287	1.1	192	7000	—	—	—	—	WR 86_192	P71	BN71B4	136
7.1	297	2.1	192	8000	—	—	—	—	WR 110_192	P71	BN71B4	140
7.6	294	1.5	120	7000	—	—	—	—	WR 86_120	P80	BN80A6	136
7.6	303	2.9	120	8000	—	—	—	—	WR 110_120	P80	BN80A6	140
7.6	255	0.9	180	6200	—	—	—	—	WR 75_180	P71	BN71B4	132
8.2	260	1.4	168	7000	—	—	—	—	WR 86_168	P71	BN71B4	136
8.2	273	2.6	168	8000	—	—	—	—	WR 110_168	P71	BN71B4	140
9.1	214	1.2	100	7000	W 86_100	S1	M1LA6	134	W 86_100	P80	BN80A6	135
9.1	224	1.2	150	6200	—	—	—	—	WR 75_150	P71	BN71B4	132
9.9	224	1.8	138	7000	—	—	—	—	WR 86_138	P71	BN71B4	136
9.9	235	3.0	138	8000	—	—	—	—	WR 110_138	P71	BN71B4	140
10.1	234	1.6	90	6200	—	—	—	—	WR 75_90	P80	BN80A6	132
11.4	168	1.2	80	6200	W 75_80	S1	M1LA6	130	W 75_80	P80	BN80A6	131
11.4	183	1.5	80	7000	W 86_80	S1	M1LA6	134	W 86_80	P80	BN80A6	135
11.4	195	1.6	120	6200	—	—	—	—	WR 75_120	P71	BN71B4	132
11.4	204	1.9	120	7000	—	—	—	—	WR 86_120	P71	BN71B4	136
12.0	179	1.0	114	5000	—	—	—	—	WR 63_114	P71	BN71B4	128
12.1	204	1.6	75	6200	—	—	—	—	WR 75_75	P80	BN80A6	132
13.2	196	2.0	69	7000	—	—	—	—	WR 86_69	P80	BN80A6	136
13.7	142	1.1	100	6200	W 75_100	S1	M1SD4	130	W 75_100	P71	BN71B4	131
13.7	152	1.5	100	7000	W 86_100	S1	M1SD4	134	W 86_100	P71	BN71B4	135
14.2	139	1.0	64	5000	W 63_64	S1	M1LA6	126	W 63_64	P80	BN80A6	127
15.2	140	1.5	60	6200	W 75_60	S1	M1LA6	130	W 75_60	P80	BN80A6	131
15.2	149	1.3	90	5000	—	—	—	—	WR 63_90	P71	BN71B4	128
15.2	160	2.0	90	6200	—	—	—	—	WR 75_90	P71	BN71B4	132
15.2	156	2.8	90	7000	—	—	—	—	WR 86_90	P71	BN71B4	136
16.3	144	2.3	56	7000	W 86_56	S1	M1LA6	134	W 86_56	P80	BN80A6	135
17.1	116	1.0	80	5000	W 63_80	S1	M1SD4	126	W 63_80	P71	BN71B4	127
17.1	122	1.5	80	6200	W 75_80	S1	M1SD4	130	W 75_80	P71	BN71B4	131
17.1	132	1.9	80	7000	W 86_80	S1	M1SD4	134	W 86_80	P71	BN71B4	135
18.3	141	2.1	75	6200	—	—	—	—	WR 75_75	P71	BN71B4	132
19.0	130	1.4	72	4830	—	—	—	—	WR 63_72	P71	BN71B4	128
19.9	133	2.8	69	7000	—	—	—	—	WR 86_69	P71	BN71B4	136
20.2	136	2.6	45	6200	—	—	—	—	WR 75_45	P80	BN80A6	132
21.4	101	1.2	64	4870	W 63_64	S1	M1SD4	126	W 63_64	P71	BN71B4	127
21.4	112	2.5	64	7000	W 86_64	S1	M1SD4	134	W 86_64	P71	BN71B4	135
22.8	101	2.0	60	6200	W 75_60	S1	M1SD4	130	W 75_60	P71	BN71B4	131
22.8	119	2.5	60	6200	—	—	—	—	WR 75_60	P71	BN71B4	132
22.8	119	3.2	60	7000	—	—	—	—	WR 86_60	P71	BN71B4	136
24.0	107	1.7	57	4540	—	—	—	—	WR 63_57	P71	BN71B4	128
24.5	101	3.0	56	7000	W 86_56	S1	M1SD4	134	W 86_56	P71	BN71B4	135
27.4	88	2.5	50	6200	W 75_50	S1	M1SD4	130	W 75_50	P71	BN71B4	131
30	73	0.9	45	2680	—	—	—	—	VF 49_45	P71	BN71B4	120
30	78	1.9	45	4400	W 63_45	S1	M1SD4	126	W 63_45	P71	BN71B4	127
30	88	2.0	45	4250	—	—	—	—	WR 63_45	P71	BN71B4	128
30	93	3.2	45	5885	—	—	—	—	WR 75_45	P71	BN71B4	132
34	74	3.4	40	5820	W 75_40	S1	M1SD4	130	W 75_40	P71	BN71B4	131
36	69	2.3	38	4180	W 63_38	S1	M1SD4	126	W 63_38	P71	BN71B4	127
38	62	1.1	36	2530	—	—	—	—	VF 49_36	P71	BN71B4	120
38	73	2.2	36	3980	—	—	—	—	WR 63_36	P71	BN71B4	128
46	57	2.8	30	3900	W 63_30	S1	M1SD4	126	W 63_30	P71	BN71B4	127
49	51	1.4	28	2360	—	—	—	—	VF 49_28	P71	BN71B4	120
57	46	1.4	24	2250	—	—	—	—	VF 49_24	P71	BN71B4	120
57	48	3.2	24	3650	W 63_24	S1	M1SD4	126	W 63_24	P71	BN71B4	127
65	42	1.7	14	1940	—	—	—	—	VF 49_14	P80	BN80A6	120
69	40	1.0	20	1870	—	—	—	—	VF 44_20	P71	BN71B4	114
72	40	3.8	19	3400	W 63_19	S1	M1SD4	126	W 63_19	P71	BN71B4	127
76	36	1.6	18	2080	—	—	—	—	VF 49_18	P71	BN71B4	120
79	33	0.9	35	1860	—	—	—	—	VF 44_35	P71	BN71A2	114
91	32	2.0	10	1930	—	—	—	—	VF 49_10	P80	BN80A6	120
98	29	1.0	14	1690	—	—	—	—	VF 44_14	P71	BN71B4	114
98	29	2.2	14	1940	—	—	—	—	VF 49_14	P71	BN71B4	120
117	24	2.0	24	1880	—	—	—	—	VF 49_24	P71	BN71A2	120
137	22	1.3	10	1520	—	—	—	—	VF 44_10	P71	BN71B4	114
137	22	2.7	10	1750	—	—	—	—	VF 49_10	P71	BN71B4	120



0.37 kW







n ₂ min ⁻¹	M ₂ Nm	S	i	Rn ₂ N						IEC 	
138	21	1.4	20	1570	—	—	—	VF 44_20	P71	BN71A2	114
153	19	2.3	18	1720	—	—	—	VF 49_18	P71	BN71A2	120
196	16	1.9	7	1360	—	—	—	VF 44_7	P71	BN71B4	114
196	16	3.5	7	1570	—	—	—	VF 49_7	P71	BN71B4	120
275	11	2.0	10	1260	—	—	—	VF 44_10	P71	BN71A2	114
393	8	2.8	7	1120	—	—	—	VF 44_7	P71	BN71A2	114

0.55 kW

n ₂ min ⁻¹	M ₂ Nm	S	i	Rn ₂ N						IEC 	
0.29	4019	1.1	3200	19500	—	—	—	W/VF 86/185_3200	P80	BN80B6	162
0.36	3946	1.1	2560	19500	—	—	—	W/VF 86/185_2560	P80	BN80B6	162
0.43	2902	1.4	3200	19500	—	—	—	W/VF 86/185_3200	P80	BN80A4	162
0.47	3004	0.9	2944	16000	—	—	—	W/VF 86/150_2944	P80	BN80A4	154
0.50	3362	1.3	1840	19500	—	—	—	W/VF 86/185_1840	P80	BN80B6	162
0.54	2805	1.5	2560	19500	—	—	—	W/VF 86/185_2560	P80	BN80A4	162
0.76	2642	1.0	1840	16000	—	—	—	W/VF 86/150_1840	P80	BN80A4	154
0.76	2364	1.8	1840	19500	—	—	—	W/VF 86/185_1840	P80	BN80A4	162
0.77	1905	0.9	1800	13800	—	—	—	W/VF 63/130_1800	P80	BN80A4	146
0.87	2116	2.0	1600	19500	—	—	—	W/VF 86/185_1600	P80	BN80A4	162
0.91	1838	1.0	1520	13800	—	—	—	W/VF 63/130_1520	P80	BN80A4	146
1.0	1996	2.2	920	19500	—	—	—	W/VF 86/185_920	P80	BN80B6	162
1.0	2190	1.2	1380	16000	—	—	—	W/VF 86/150_1380	P80	BN80A4	154
1.2	1542	1.2	1200	13800	—	—	—	W/VF 63/130_1200	P80	BN80A4	146
1.2	1542	2.7	1200	19500	—	—	—	W/VF 86/185_1200	P80	BN80A4	162
1.3	1852	1.5	690	16000	—	—	—	W/VF 86/150_690	P80	BN80B6	154
1.4	1342	1.3	960	13800	—	—	—	W/VF 63/130_960	P80	BN80A4	146
1.5	1564	1.7	920	16000	—	—	—	W/VF 86/150_920	P80	BN80A4	154
1.5	1460	2.9	920	19500	—	—	—	W/VF 86/185_920	P80	BN80A4	162
1.5	1473	3.0	600	19500	—	—	—	W/VF 86/185_600	P80	BN80B6	162
1.7	1300	3.2	800	19500	—	—	—	W/VF 86/185_800	P80	BN80A4	162
1.7	1570	1.7	529	16000	—	—	—	W/VF 86/150_529	P80	BN80B6	154
1.8	1120	1.6	760	13800	—	—	—	W/VF 63/130_760	P80	BN80A4	146
2.0	1304	2.0	690	16000	—	—	—	W/VF 86/150_690	P80	BN80A4	154
2.3	1028	1.0	400	8000	—	—	—	VF/W 49/110_400	P80	BN80B6	141
2.3	907	2.0	600	13800	—	—	—	W/VF 63/130_600	P80	BN80A4	146
2.6	837	1.2	540	8000	—	—	—	VF/W 49/110_540	P80	BN80A4	141
2.6	1099	2.4	529	16000	—	—	—	W/VF 86/150_529	P80	BN80A4	154
3.0	956	2.7	460	16000	—	—	—	W/VF 86/150_460	P80	BN80A4	154
3.1	839	1.2	300	13800	—	—	—	VFR 130_300	P80	BN80B6	144
3.1	805	1.3	300	8000	—	—	—	VF/W 49/110_300	P80	BN80B6	141
3.5	680	1.5	400	8000	—	—	—	VF/W 49/110_400	P80	BN80A4	141
3.5	665	2.7	400	13800	—	—	—	W/VF 63/130_400	P80	BN80A4	146
3.8	740	1.6	240	13800	—	—	—	VFR 130_240	P80	BN80B6	144
4.0	670	1.6	230	8000	—	—	—	VF/W 49/110_230	P80	BN80B6	141
4.0	756	3.4	345	16000	—	—	—	W/VF 86/150_345	P80	BN80A4	154
4.6	578	0.9	300	8000	—	—	—	WR 110_300	P80	BN80A4	140
4.6	601	1.5	300	13800	—	—	—	VFR 130_300	P80	BN80A4	144
4.6	544	1.8	300	8000	—	—	—	VF/W 49/110_300	P80	BN80A4	141
4.8	625	1.1	192	8000	—	—	—	WR 110_192	P80	BN80B6	140
5.0	529	3.4	280	13800	—	—	—	W/VF 63/130_280	P80	BN80A4	146
5.8	508	1.1	240	8000	—	—	—	WR 110_240	P80	BN80A4	140
5.8	517	2.2	240	13800	—	—	—	VFR 130_240	P80	BN80A4	144
6.0	452	2.2	230	8000	—	—	—	VF/W 49/110_230	P80	BN80A4	141
6.7	504	3.0	138	13800	—	—	—	VFR 130_138	P80	BN80B6	144
7.2	435	1.4	192	8000	—	—	—	WR 110_192	P80	BN80A4	140
7.2	443	2.7	192	13800	—	—	—	VFR 130_192	P80	BN80A4	144
7.7	432	1.0	120	7000	—	—	—	WR 86_120	P80	BN80B6	136
8.3	381	0.9	168	7000	—	—	—	WR 86_168	P80	BN80A4	136
8.3	400	1.8	168	8000	—	—	—	WR 110_168	P80	BN80A4	140
8.3	406	3.0	168	13800	—	—	—	VFR 130_168	P80	BN80A4	144









0.55 kW

n ₂ min ⁻¹	M ₂ Nm	S	i	R _{n2} N						IEC 		
9.2	325	1.5	100	8000	W 110_100	S2	M2SA6	138	W 110_100	P80	BN80B6	139
10.1	329	1.2	138	7000	—	—	—	—	WR 86_138	P80	BN80A4	136
10.1	344	2.1	138	8000	—	—	—	—	WR 110_138	P80	BN80A4	140
10.2	344	1.1	90	6200	—	—	—	—	WR 75_90	P80	BN80B6	132
11.5	269	1.0	80	7000	W 86_80	S2	M2SA6	134	W 86_80	P80	BN80B6	135
11.6	286	1.1	120	6200	—	—	—	—	WR 75_120	P80	BN80A4	132
11.6	299	1.3	120	7000	—	—	—	—	WR 86_120	P80	BN80A4	136
11.6	308	2.6	120	8000	—	—	—	—	WR 110_120	P80	BN80A4	140
12.3	300	1.1	75	6200	—	—	—	—	WR 75_75	P80	BN80B6	132
13.3	288	1.4	69	7000	—	—	—	—	WR 86_69	P80	BN80B6	136
13.3	295	2.5	69	8000	—	—	—	—	WR 110_69	P80	BN80B6	140
13.8	225	1.0	100	7000	W 86_100	S1	M1LA4	134	W 86_100	P80	BN80A4	135
15.4	235	1.4	90	6200	—	—	—	—	WR 75_90	P80	BN80A4	132
15.4	228	1.9	90	7000	—	—	—	—	WR 86_90	P80	BN80A4	136
15.4	238	3.5	90	8000	—	—	—	—	WR 110_90	P80	BN80A4	140
16.4	211	1.5	56	7000	W 86_56	S2	M2SA6	134	W 86_56	P80	BN80B6	135
17.3	180	1.0	80	6200	W 75_80	S1	M1LA4	130	W 75_80	P80	BN80A4	131
17.3	195	1.3	80	7000	W 86_80	S1	M1LA4	134	W 86_80	P80	BN80A4	135
18.5	207	1.4	75	6200	—	—	—	—	WR 75_75	P80	BN80A4	132
20.1	196	1.9	69	7000	—	—	—	—	WR 86_69	P80	BN80A4	136
20.1	201	3.2	69	8000	—	—	—	—	WR 110_69	P80	BN80A4	140
20.4	162	1.0	45	4540	W 63_45	S2	M2SA6	126	W 63_45	P80	BN80B6	127
21.6	166	1.7	64	7000	W 86_64	S1	M1LA4	134	W 86_64	P80	BN80A4	135
23.0	148	1.3	60	6200	W 75_60	S1	M1LA4	130	W 75_60	P80	BN80A4	131
23.0	162	2.2	40	7000	W 86_40	S2	M2SA6	134	W 86_40	P80	BN80B6	135
23.2	175	1.7	60	6040	—	—	—	—	WR 75_60	P80	BN80A4	132
23.2	175	2.2	60	7000	—	—	—	—	WR 86_60	P80	BN80A4	136
24.2	143	1.2	38	4340	W 63_38	S2	M2SA6	126	W 63_38	P80	BN80B6	127
24.6	149	2.0	56	7000	W 86_56	S1	M1LA4	134	W 86_56	P80	BN80A4	135
27.6	129	1.7	50	5960	W 75_50	S1	M1LA4	130	W 75_50	P80	BN80A4	131
30	128	2.7	46	7000	W 86_46	S1	M1LA4	134	W 86_46	P80	BN80A4	135
31	115	1.3	45	4140	W 63_45	S1	M1LA4	126	W 63_45	P80	BN80A4	127
31	136	2.2	45	5580	—	—	—	—	WR 75_45	P80	BN80A4	132
31	133	2.9	45	7000	—	—	—	—	WR 86_45	P80	BN80A4	136
35	110	2.3	40	5610	W 75_40	S1	M1LA4	130	W 75_40	P80	BN80A4	131
35	114	2.9	40	7000	W 86_40	S1	M1LA4	134	W 86_40	P80	BN80A4	135
36	101	1.5	38	3950	W 63_38	S1	M1LA4	126	W 63_38	P80	BN80A4	127
40	105	3.3	23	7000	W 86_23	S2	M2SA6	134	W 86_23	P80	BN80B6	135
46	84	1.9	30	3700	W 63_30	S1	M1LA4	126	W 63_30	P80	BN80A4	127
46	88	3.1	30	5150	W 75_30	S1	M1LA4	130	W 75_30	P80	BN80A4	131
46	95	2.9	30	4950	—	—	—	—	WR 75_30	P80	BN80A4	132
49	76	1.0	28	2170	—	—	—	—	VF 49_28	P80	BN80A4	120
55	76	3.3	25	4880	W 75_25	S1	M1LA4	130	W 75_25	P80	BN80A4	131
58	69	0.9	24	2080	—	—	—	—	VF 49_24	P80	BN80A4	120
58	71	2.2	24	3480	W 63_24	S1	M1LA4	126	W 63_24	P80	BN80A4	127
66	62	1.1	14	1960	—	—	—	—	VF 49_14	P80	BN80B6	120
73	59	2.6	19	3260	W 63_19	S1	M1LA4	126	W 63_19	P80	BN80A4	127
77	53	1.1	18	1930	—	—	—	—	VF 49_18	P80	BN80A4	120
92	47	1.4	10	1800	—	—	—	—	VF 49_10	P80	BN80B6	120
92	47	3.2	15	3050	W 63_15	S1	M1LA4	126	W 63_15	P80	BN80A4	127
99	43	1.5	14	1810	—	—	—	—	VF 49_14	P80	BN80A4	120
115	39	3.6	12	2850	W 63_12	S1	M1LA4	126	W 63_12	P80	BN80A4	127
117	35	1.3	24	1800	—	—	—	—	VF 49_24	P71	BN71B2	120
131	35	3.7	7	2700	W 63_7	S2	M2SA6	126	W 63_7	P80	BN80B6	127
138	32	1.8	10	1650	—	—	—	—	VF 49_10	P80	BN80A4	120
141	30	1.0	20	1490	—	—	—	—	VF 44_20	P71	BN71B2	114
156	28	1.6	18	1650	—	—	—	—	VF 49_18	P71	BN71B2	120
197	23	2.4	7	1480	—	—	—	—	VF 49_7	P80	BN80A4	120
281	16	1.4	10	1210	—	—	—	—	VF 44_10	P71	BN71B2	114
281	16	2.7	10	1390	—	—	—	—	VF 49_10	P71	BN71B2	120
401	12	1.9	7	1080	—	—	—	—	VF 44_7	P71	BN71B2	114









0.75 kW







n ₂ min-1	M ₂ Nm	S	i	R _{n2} N						IEC 		
0.29	4983	1.3	3200	34500	—	—	—	VF/VF 130/210_3200	P90	BN90S6	170	
0.29	4733	1.9	3200	52000	—	—	—	VF/VF 130/250_3200	P90	BN90S6	176	
0.36	4783	1.4	2560	34500	—	—	—	VF/VF 130/210_2560	P90	BN90S6	170	
0.36	4584	2.0	2560	52000	—	—	—	VF/VF 130/250_2560	P90	BN90S6	176	
0.44	3929	1.1	3200	19500	—	—	—	W/VF 86/185_3200	P80	BN80B4	162	
0.50	4584	1.0	1840	19500	—	—	—	W/VF 86/185_1840	P90	BN90S6	162	
0.50	4011	1.6	1840	34500	—	—	—	VF/VF 130/210_1840	P90	BN90S6	170	
0.50	4154	2.2	1840	52000	—	—	—	VF/VF 130/250_1840	P90	BN90S6	176	
0.55	3798	1.1	2560	19500	—	—	—	W/VF 86/185_2560	P80	BN80B4	162	
0.76	3201	1.3	1840	19500	—	—	—	W/VF 86/185_1840	P80	BN80B4	162	
0.88	2865	1.5	1600	19500	—	—	—	W/VF 86/185_1600	P80	BN80B4	162	
1.0	2722	1.6	920	19500	—	—	—	W/VF 86/185_920	P90	BN90S6	162	
1.2	2087	0.9	1200	13800	—	—	—	W/VF 63/130_1200	P80	BN80B4	146	
1.2	2087	2.0	1200	19500	—	—	—	W/VF 86/185_1200	P80	BN80B4	162	
1.3	2525	1.1	690	16000	—	—	—	W/VF 86/150_690	P90	BN90S6	154	
1.5	1817	1.0	960	13800	—	—	—	W/VF 63/130_960	P80	BN80B4	146	
1.5	2118	1.2	920	16000	—	—	—	W/VF 86/150_920	P80	BN80B4	154	
1.5	1977	2.1	920	19500	—	—	—	W/VF 86/185_920	P80	BN80B4	162	
1.7	2142	1.3	529	16000	—	—	—	W/VF 86/150_529	P90	BN90S6	154	
1.8	1760	2.4	800	19500	—	—	—	W/VF 86/185_800	P80	BN80B4	162	
1.8	1516	1.2	760	13800	—	—	—	W/VF 63/130_760	P80	BN80B4	146	
2.0	1765	1.5	690	16000	—	—	—	W/VF 86/150_690	P80	BN80B4	154	
2.3	1228	1.5	600	13800	—	—	—	W/VF 63/130_600	P80	BN80B4	146	
2.3	1381	3.0	600	19500	—	—	—	W/VF 86/185_600	P80	BN80B4	162	
2.6	1489	1.7	529	16000	—	—	—	W/VF 86/150_529	P80	BN80B4	154	
3.0	1294	2.0	460	16000	—	—	—	W/VF 86/150_460	P80	BN80B4	154	
3.1	1144	0.9	300	13800	—	—	—	VFR 130_300	P90	BN90S6	144	
3.1	1167	1.2	300	16000	—	—	—	VFR 150_300	P90	BN90S6	152	
3.1	1168	2.1	300	19500	—	—	—	VFR 185_300	P90	BN90S6	160	
3.5	921	1.1	400	8000	—	—	—	VF/W 49/110_400	P80	BN80B4	141	
3.5	900	2.0	400	13800	—	—	—	W/VF 63/130_400	P80	BN80B4	146	
3.8	1009	1.2	240	13800	—	—	—	VFR 130_240	P90	BN90S6	144	
3.8	1009	1.7	240	16000	—	—	—	VFR 150_240	P90	BN90S6	152	
3.8	1009	2.8	240	19500	—	—	—	VFR 185_240	P90	BN90S6	160	
4.1	1024	2.5	345	16000	—	—	—	W/VF 86/150_345	P80	BN80B4	154	
4.7	813	1.1	300	13800	—	—	—	VFR 130_300	P80	BN80B4	144	
4.7	737	1.4	300	8000	—	—	—	VF/W 49/110_300	P80	BN80B4	141	
4.7	890	2.9	300	16000	—	—	—	W/VF 86/150_300	P80	BN80B4	154	
4.8	882	2.2	192	16000	—	—	—	VFR 150_192	P90	BN90S6	152	
5.0	716	2.5	280	13800	—	—	—	W/VF 63/130_280	P80	BN80B4	146	
5.5	785	1.0	168	8000	—	—	—	WR 110_168	P90	BN90S6	140	
5.5	798	2.4	168	16000	—	—	—	VFR 150_168	P90	BN90S6	152	
5.8	700	1.6	240	13800	—	—	—	VFR 130_240	P80	BN80B4	144	
6.1	612	1.6	230	8000	—	—	—	VF/W 49/110_230	P80	BN80B4	141	
6.7	677	1.2	138	8000	—	—	—	WR 110_138	P90	BN90S6	140	
6.7	688	2.2	138	13800	—	—	—	VFR 130_138	P90	BN90S6	144	
6.7	688	3.2	138	16000	—	—	—	VFR 150_138	P90	BN90S6	152	
7.3	589	1.1	192	8000	—	—	—	WR 110_192	P80	BN80B4	140	
7.3	599	2.0	192	13800	—	—	—	VFR 130_192	P80	BN80B4	144	
8.3	541	1.3	168	8000	—	—	—	WR 110_168	P80	BN80B4	140	
8.3	550	2.2	168	13800	—	—	—	VFR 130_168	P80	BN80B4	144	
9.2	444	1.1	100	8000	W 110_100	S2	M2SB6	138	W 110_100	P90	BN90S6	139
9.2	459	1.7	100	13200	—	—	—	VF 130_100	P90	BN90S6	142	
10.1	445	0.9	138	7000	—	—	—	WR 86_138	P80	BN80B4	136	
10.1	466	1.5	138	8000	—	—	—	WR 110_138	P80	BN80B4	140	
10.1	473	2.9	138	13800	—	—	—	VFR 130_138	P80	BN80B4	144	
11.5	411	1.1	80	8000	W 110_80	S2	M2SB6	138	W 110_80	P90	BN90S6	139
11.5	399	2.4	80	13200	—	—	—	VF 130_80	P90	BN90S6	142	
11.7	405	1.0	120	7000	—	—	—	WR 86_120	P80	BN80B4	136	
11.7	417	1.9	120	8000	—	—	—	WR 110_120	P80	BN80B4	140	
11.7	411	3.4	120	13800	—	—	—	VFR 130_120	P80	BN80B4	144	
13.3	403	1.9	69	8000	—	—	—	WR 110_69	P90	BN90S6	140	
14.0	317	1.5	100	8000	W 110_100	S2	M2SA4	138	W 110_100	P80	BN80B4	139
14.4	314	1.0	64	7000	W 86_64	S2	M2SB6	134	W 86_64	P90	BN90S6	135
14.4	339	3.1	64	13200	—	—	—	VF 130_64	P90	BN90S6	142	



0.75 kW







n ₂ min ⁻¹	M ₂ Nm	S	i	R _{n2} N						IEC 		
15.6	318	1.0	90	6200	—	—	—	—	WR 75_90	P80	BN80B4	132
15.6	308	1.4	90	7000	—	—	—	—	WR 86_90	P80	BN80B4	136
15.6	322	2.6	90	8000	—	—	—	—	WR 110_90	P80	BN80B4	140
16.4	288	1.1	56	7000	W 86_56	S2	M2SB6	134	W 86_56	P90	BN90S6	135
16.4	296	2.2	56	8000	W 110_56	S2	M2SB6	138	W 110_56	P90	BN90S6	139
17.5	262	1.0	80	7000	W 86_80	S2	M2SA4	134	W 86_80	P80	BN80B4	135
17.5	270	1.7	80	8000	W 110_80	S2	M2SA4	138	W 110_80	P80	BN80B4	139
18.4	245	1.0	50	6200	W 75_50	S2	M2SB6	130	W 75_50	P90	BN90S6	131
18.7	280	1.1	75	5980	—	—	—	—	WR 75_75	P80	BN80B4	132
20.3	265	1.4	69	7000	—	—	—	—	WR 86_69	P80	BN80B4	136
20.3	272	2.4	69	8000	—	—	—	—	WR 110_69	P80	BN80B4	140
20.4	273	1.3	45	6010	—	—	—	—	WR 75_45	P90	BN90S6	132
21.9	223	1.3	64	7000	W 86_64	S2	M2SA4	134	W 86_64	P80	BN80B4	135
21.9	229	2.3	64	8000	W 110_64	S2	M2SA4	138	W 110_64	P80	BN80B4	139
23.0	212	1.3	40	5930	W 75_40	S2	M2SB6	130	W 75_40	P90	BN90S6	131
23.3	200	1.0	60	5960	W 75_60	S2	M2SA4	130	W 75_60	P80	BN80B4	131
23.3	236	1.2	60	5640	—	—	—	—	WR 75_60	P80	BN80B4	132
23.3	236	1.6	60	7000	—	—	—	—	WR 86_60	P80	BN80B4	136
23.3	243	2.8	60	8000	—	—	—	—	WR 110_60	P80	BN80B4	140
25.0	201	1.5	56	7000	W 86_56	S2	M2SA4	134	W 86_56	P80	BN80B4	135
25.0	206	2.9	56	8000	W 110_56	S2	M2SA4	138	W 110_56	P80	BN80B4	139
28.0	174	1.3	50	5670	W 75_50	S2	M2SA4	130	W 75_50	P80	BN80B4	131
30	172	2.0	46	7000	W 86_46	S2	M2SA4	134	W 86_46	P80	BN80B4	135
30	174	3.4	46	8000	W 110_46	S2	M2SA4	138	W 110_46	P80	BN80B4	139
31	154	0.9	45	3860	W 63_45	S2	M2SA4	126	W 63_45	P80	BN80B4	127
31	184	1.6	45	5250	—	—	—	—	WR 75_45	P80	BN80B4	132
31	180	2.2	45	7000	—	—	—	—	WR 86_45	P80	BN80B4	136
35	147	1.7	40	5370	W 75_40	S2	M2SA4	130	W 75_40	P80	BN80B4	131
35	153	2.2	40	7000	W 86_40	S2	M2SA4	134	W 86_40	P80	BN80B4	135
37	136	1.1	38	3700	W 63_38	S2	M2SA4	126	W 63_38	P80	BN80B4	127
40	143	2.4	23	7000	W 86_23	S2	M2SB6	134	W 86_23	P90	BN90S6	135
47	114	1.4	30	3490	W 63_30	S2	M2SA4	126	W 63_30	P80	BN80B4	127
47	129	2.1	30	4680	—	—	—	—	WR 75_30	P80	BN80B4	132
47	118	2.3	30	4950	W 75_30	S2	M2SA4	130	W 75_30	P80	BN80B4	131
47	117	3.2	30	7000	W 86_30	S2	M2SA4	134	W 86_30	P80	BN80B4	135
56	102	2.4	25	4700	W 75_25	S2	M2SA4	130	W 75_25	P80	BN80B4	131
58	96	1.6	24	3290	W 63_24	S2	M2SA4	126	W 63_24	P80	BN80B4	127
61	96	3.3	23	7000	W 86_23	S2	M2SA4	134	W 86_23	P80	BN80B4	135
70	85	2.9	20	4400	W 75_20	S2	M2SA4	130	W 75_20	P80	BN80B4	131
74	79	1.9	19	3100	W 63_19	S2	M2SA4	126	W 63_19	P80	BN80B4	127
93	64	2.4	15	2910	W 63_15	S2	M2SA4	126	W 63_15	P80	BN80B4	127
100	58	1.1	14	1690	—	—	—	—	VF 49_14	P80	BN80B4	120
117	49	1.0	24	1710	—	—	—	—	VF 49_24	P80	BN80A2	120
117	52	2.7	12	2740	W 63_12	S2	M2SA4	126	W 63_12	P80	BN80B4	127
131	47	2.7	7	2590	W 63_7	S2	M2SB6	126	W 63_7	P90	BN90S6	127
140	43	1.4	10	1540	—	—	—	—	VF 49_10	P80	BN80B4	120
140	44	3.2	10	2600	W 63_10	S2	M2SA4	126	W 63_10	P80	BN80B4	127
187	33	3.8	15	2440	W 63_15	S1	M1LA2	126	W 63_15	P80	BN80A2	127
200	31	1.8	7	1400	—	—	—	—	VF 49_7	P80	BN80B4	120
200	32	3.8	7	2340	W 63_7	S2	M2SA4	126	W 63_7	P80	BN80B4	127
280	22	2.0	10	1340	—	—	—	—	VF 49_10	P80	BN80A2	120
400	16	2.6	7	1200	—	—	—	—	VF 49_7	P80	BN80A2	120

1.1 kW

n ₂ min ⁻¹	M ₂ Nm	S	i	R _{n2} N						IEC 		
0.29	7308	0.9	3200	34500	—	—	—	—	VF/VF 130/210_3200	P90	BN90L6	170
0.29	6942	1.3	3200	52000	—	—	—	—	VF/VF 130/250_3200	P90	BN90L6	176
0.36	7016	0.9	2560	34500	—	—	—	—	VF/VF 130/210_2560	P90	BN90L6	170
0.36	6723	1.4	2560	52000	—	—	—	—	VF/VF 130/250_2560	P90	BN90L6	176
0.44	5283	1.2	3200	34500	—	—	—	—	VF/VF 130/210_3200	P90	BN90S4	170









1.1 kW







n ₂ min-1	M ₂ Nm	S	i	R _{n2} N						IEC 		
0.44	5042	1.8	3200	52000	—	—	—	VF/VF 130/250_3200	P90	BN90S4	176	
0.50	7143	0.9	1840	34500	—	—	—	VF/VF 130/210_1840	P90	BN90L6	170	
0.50	6093	1.5	1840	52000	—	—	—	VF/VF 130/250_1840	P90	BN90L6	176	
0.55	4610	1.4	2560	34500	—	—	—	VF/VF 130/210_2560	P90	BN90S4	170	
0.55	4802	1.9	2560	52000	—	—	—	VF/VF 130/250_2560	P90	BN90S4	176	
0.76	4694	0.9	1840	19500	—	—	—	W/VF 86/185_1840	P90	BN90S4	162	
0.76	4832	1.3	1840	34500	—	—	—	VF/VF 130/210_1840	P90	BN90S4	170	
0.76	4280	2.1	1840	52000	—	—	—	VF/VF 130/250_1840	P90	BN90S4	176	
0.88	4202	1.0	1600	19500	—	—	—	W/VF 86/185_1600	P90	BN90S4	162	
1.0	3992	1.1	920	19500	—	—	—	W/VF 86/185_920	P90	BN90L6	162	
1.2	3061	1.4	1200	19500	—	—	—	W/VF 86/185_1200	P90	BN90S4	162	
1.5	2899	1.4	920	19500	—	—	—	W/VF 86/185_920	P90	BN90S4	162	
1.8	2581	1.6	800	19500	—	—	—	W/VF 86/185_800	P90	BN90S4	162	
2.0	2589	1.0	690	16000	—	—	—	W/VF 86/150_690	P90	BN90S4	154	
2.3	1801	1.0	600	13800	—	—	—	W/VF 63/130_600	P90	BN90S4	146	
2.3	2026	2.1	600	19500	—	—	—	W/VF 86/185_600	P90	BN90S4	162	
2.6	2183	1.2	529	16000	—	—	—	W/VF 86/150_529	P90	BN90S4	154	
3.0	1898	1.4	460	16000	—	—	—	W/VF 86/150_460	P90	BN90S4	154	
3.1	1713	1.4	300	19500	—	—	—	VFR 185_300	P90	BN90L6	160	
3.5	1321	1.4	400	13800	—	—	—	W/VF 63/130_400	P90	BN90S4	146	
3.5	1441	2.9	400	19500	—	—	—	W/VF 86/185_400	P90	BN90S4	162	
3.8	1480	1.1	240	16000	—	—	—	VFR 150_240	P90	BN90L6	152	
3.8	1480	1.9	240	19500	—	—	—	VFR 185_240	P90	BN90L6	160	
4.1	1501	1.7	345	16000	—	—	—	W/VF 86/150_345	P90	BN90S4	154	
4.7	1222	1.1	300	16000	—	—	—	VFR 150_300	P90	BN90S4	152	
4.7	1238	1.9	300	19500	—	—	—	VFR 185_300	P90	BN90S4	160	
4.7	1306	2.0	300	16000	—	—	—	W/VF 86/150_300	P90	BN90S4	154	
4.8	1272	1.0	192	13800	—	—	—	VFR 130_192	P90	BN90L6	144	
5.0	1051	1.7	280	13800	—	—	—	W/VF 63/130_280	P90	BN90S4	146	
5.8	1026	1.1	240	13800	—	—	—	VFR 130_240	P90	BN90S4	144	
5.8	1044	1.5	240	16000	—	—	—	VFR 150_240	P90	BN90S4	152	
5.8	1063	2.6	240	19500	—	—	—	VFR 185_240	P90	BN90S4	160	
6.2	1064	2.4	225	16000	—	—	—	W/VF 86/150_225	P90	BN90S4	154	
6.7	1008	1.5	138	13800	—	—	—	VFR 130_138	P90	BN90L6	144	
6.7	1008	2.2	138	16000	—	—	—	VFR 150_138	P90	BN90L6	152	
7.0	960	2.7	200	16000	—	—	—	W/VF 86/150_200	P90	BN90S4	154	
7.3	879	1.4	192	13800	—	—	—	VFR 130_192	P90	BN90S4	144	
7.3	893	1.9	192	16000	—	—	—	VFR 150_192	P90	BN90S4	152	
7.7	891	1.0	120	8000	—	—	—	WR 110_120	P90	BN90L6	140	
7.8	878	3.4	180	19500	—	—	—	VFR 185_180	P90	BN90S4	160	
8.3	807	1.5	168	13800	—	—	—	VFR 130_168	P90	BN90S4	144	
8.3	819	2.1	168	16000	—	—	—	VFR 150_168	P90	BN90S4	152	
9.2	674	1.2	100	13200	—	—	—	VF 130_100	P90	BN90L6	142	
10.1	683	1.0	138	8000	—	—	—	WR 110_138	P90	BN90S4	140	
10.1	694	1.9	138	13800	—	—	—	VFR 130_138	P90	BN90S4	144	
10.1	704	2.8	138	16000	—	—	—	VFR 150_138	P90	BN90S4	152	
10.2	678	1.3	90	8000	—	—	—	WR 110_90	P90	BN90L6	140	
11.5	585	1.6	80	13200	—	—	—	VF 130_80	P90	BN90L6	142	
11.7	612	1.3	120	8000	—	—	—	WR 110_120	P90	BN90S4	140	
11.7	603	2.3	120	13800	—	—	—	VFR 130_120	P90	BN90S4	144	
11.7	612	3.3	120	16000	—	—	—	VFR 150_120	P90	BN90S4	152	
14.0	465	1.0	100	8000	W 110_100	S2	M2SB4	138	W 110_100	P90	BN90S4	139
14.0	525	1.1	100	12600	—	—	—	VF 130_100	P90	BN90S4	142	
15.6	473	1.8	90	8000	—	—	—	WR 110_90	P90	BN90S4	140	
15.6	479	3.1	90	13800	—	—	—	VFR 130_90	P90	BN90S4	144	
17.5	396	1.2	80	8000	W 110_80	S2	M2SB4	138	W 110_80	P90	BN90S4	139
17.5	408	2.2	80	12600	—	—	—	VF 130_80	P90	BN90S4	142	
20.0	362	1.0	46	7000	W 86_46	S3	M3SA6	134	W 86_46	P90	BN90L6	135
20.0	383	3.0	46	13200	—	—	—	VF 130_46	P90	BN90L6	142	
20.3	388	1.0	69	7000	—	—	—	WR 86_69	P90	BN90S4	136	
20.3	399	1.6	69	8000	—	—	—	WR 110_69	P90	BN90S4	140	
20.3	393	3.3	69	13800	—	—	—	VFR 130_69	P90	BN90S4	144	
21.9	336	1.6	64	8000	W 110_64	S2	M2SB4	138	W 110_64	P90	BN90S4	139
21.9	341	2.7	64	12600	—	—	—	VF 130_64	P90	BN90S4	142	
23.0	324	1.1	40	7000	W 86_40	S3	M3SA6	134	W 86_40	P90	BN90L6	135



1.1 kW







n ₂ min-1	M ₂ Nm	S	i	R _{n2} N						IEC 		
23.3	347	1.1	60	7000	—	—	—	—	WR 86_60	P90	BN90S4	136
23.3	356	1.9	60	8000	—	—	—	—	WR 110_60	P90	BN90S4	140
25.0	294	1.0	56	7000	W 86_56	S2	M2SB4	134	W 86_56	P90	BN90S4	135
25.0	303	2.0	56	8000	W 110_56	S2	M2SB4	138	W 110_56	P90	BN90S4	139
25.0	307	3.1	56	12600	—	—	—	—	VF 130_56	P90	BN90S4	142
30	252	1.3	46	7000	W 86_46	S2	M2SB4	134	W 86_46	P90	BN90S4	135
30	255	2.3	46	8000	W 110_46	S2	M2SB4	138	W 110_46	P90	BN90S4	139
31	270	1.1	45	5010	—	—	—	—	WR 75_45	P90	BN90S4	132
31	263	1.5	45	7000	—	—	—	—	WR 86_45	P90	BN90S4	136
31	270	2.6	45	8000	—	—	—	—	WR 110_45	P90	BN90S4	140
35	216	1.2	40	4980	W 75_40	S2	M2SB4	130	W 75_40	P90	BN90S4	131
35	225	1.5	40	7000	W 86_40	S2	M2SB4	134	W 86_40	P90	BN90S4	135
35	228	2.9	40	8000	W 110_40	S2	M2SB4	138	W 110_40	P90	BN90S4	139
37	217	1.2	37.5	4790	—	—	—	—	WR 75_37.5	P90	BN90S4	132
40	210	1.6	23	7000	W 86_23	S3	M3SA6	134	W 86_23	P90	BN90L6	135
41	207	1.7	34.5	7000	—	—	—	—	WR 86_34.5	P90	BN90S4	136
47	167	1.0	30	3130	W 63_30	S2	M2SB4	126	W 63_30	P90	BN90S4	127
47	189	1.5	30	4530	—	—	—	—	WR 75_30	P90	BN90S4	132
47	173	1.6	30	4640	W 75_30	S2	M2SB4	130	W 75_30	P90	BN90S4	131
47	185	1.9	30	7000	—	—	—	—	WR 86_30	P90	BN90S4	136
47	171	2.2	30	7000	W 86_30	S2	M2SB4	134	W 86_30	P90	BN90S4	135
56	150	1.7	25	4420	W 75_25	S2	M2SB4	130	W 75_25	P90	BN90S4	131
58	140	1.1	24	2990	W 63_24	S2	M2SB4	126	W 63_24	P90	BN90S4	127
61	142	2.3	23	7000	W 86_23	S2	M2SB4	134	W 86_23	P90	BN90S4	135
70	125	2.0	20	4160	W 75_20	S2	M2SB4	130	W 75_20	P90	BN90S4	131
70	126	2.5	20	7000	W 86_20	S2	M2SB4	134	W 86_20	P90	BN90S4	135
74	115	1.3	19	2840	W 63_19	S2	M2SB4	126	W 63_19	P90	BN90S4	127
93	93	1.6	15	2690	W 63_15	S2	M2SB4	126	W 63_15	P90	BN90S4	127
93	96	2.6	15	3850	W 75_15	S2	M2SB4	130	W 75_15	P90	BN90S4	131
93	96	3.4	15	6820	W 86_15	S2	M2SB4	134	W 86_15	P90	BN90S4	135
117	77	1.8	12	2550	W 63_12	S2	M2SB4	126	W 63_12	P90	BN90S4	127
140	65	2.2	10	2440	W 63_10	S2	M2SB4	126	W 63_10	P90	BN90S4	127
140	66	3.5	10	3420	W 75_10	S2	M2SB4	130	W 75_10	P90	BN90S4	131
187	48	2.6	15	2330	W 63_15	S2	M2SA2	126	W 63_15	P80	BN80B2	127
200	44	1.1	14	1370	—	—	—	—	VF 49_14	P80	BN80B2	120
200	46	2.6	7	2210	W 63_7	S2	M2SB4	126	W 63_7	P90	BN90S4	127
233	39	3.2	12	2190	W 63_12	S2	M2SA2	126	W 63_12	P80	BN80B2	127
280	32	1.4	10	1250	—	—	—	—	VF 49_10	P80	BN80B2	120
280	33	3.8	10	2080	W 63_10	S2	M2SA2	126	W 63_10	P80	BN80B2	127
400	23	1.8	7	1130	—	—	—	—	VF 49_7	P80	BN80B2	120

1.5 kW

n ₂ min-1	M ₂ Nm	S	i	R _{n2} N						IEC 		
0.29	9266	1.0	3200	52000	—	—	—	—	VF/VF 130/250_3200	P100	BN100LA6	176
0.37	8973	1.0	2560	52000	—	—	—	—	VF/VF 130/250_2560	P100	BN100LA6	176
0.44	7152	0.9	3200	34500	—	—	—	—	VF/VF 130/210_3200	P90	BN90LA4	170
0.44	6827	1.3	3200	52000	—	—	—	—	VF/VF 130/250_3200	P90	BN90LA4	176
0.51	8132	1.1	1840	52000	—	—	—	—	VF/VF 130/250_1840	P100	BN100LA6	176
0.55	6242	1.0	2560	34500	—	—	—	—	VF/VF 130/210_2560	P90	BN90LA4	170
0.55	6502	1.4	2560	52000	—	—	—	—	VF/VF 130/250_2560	P90	BN90LA4	176
0.77	6543	1.0	1840	34500	—	—	—	—	VF/VF 130/210_1840	P90	BN90LA4	170
0.77	5795	1.6	1840	52000	—	—	—	—	VF/VF 130/250_1840	P90	BN90LA4	176
1.0	4907	1.3	920	34500	—	—	—	—	VF/VF 130/210_920	P100	BN100LA6	170
1.0	4907	1.9	920	52000	—	—	—	—	VF/VF 130/250_920	P100	BN100LA6	176
1.2	4145	1.0	1200	19500	—	—	—	—	W/VF 86/185_1200	P90	BN90LA4	162
1.2	4633	1.4	800	34500	—	—	—	—	VF/VF 130/210_800	P100	BN100LA6	170
1.2	4877	1.9	800	52000	—	—	—	—	VF/VF 130/250_800	P100	BN100LA6	176
1.5	3926	1.1	920	19500	—	—	—	—	W/VF 86/185_920	P90	BN90LA4	162
1.6	3932	1.7	600	34500	—	—	—	—	VF/VF 130/210_600	P100	BN100LA6	170
1.6	3932	2.3	600	52000	—	—	—	—	VF/VF 130/250_600	P100	BN100LA6	176









1.5 kW







n ₂ min-1	M ₂ Nm	S	i	R _{n2} N						IEC 		
1.8	3495	1.2	800	19500	—	—	—	W/VF 86/185_800	P90	BN90LA4	162	
2.4	2743	1.5	600	19500	—	—	—	W/VF 86/185_600	P90	BN90LA4	162	
2.4	2926	2.2	400	34500	—	—	—	VF/VF 130/210_400	P100	BN100LA6	170	
2.4	2865	3.2	400	52000	—	—	—	VF/VF 130/250_400	P100	BN100LA6	176	
2.7	2956	0.9	529	16000	—	—	—	W/VF 86/150_529	P90	BN90LA4	154	
3.1	2570	1.0	460	16000	—	—	—	W/VF 86/150_460	P90	BN90LA4	154	
3.1	2286	1.0	300	19500	—	—	—	VFR 185_300	P100	BN100LA6	160	
3.1	2240	1.6	300	34500	—	—	—	VFR 210_300	P100	BN100LA6	168	
3.1	2377	2.2	300	52000	—	—	—	VFR 250_300	P100	BN100LA6	174	
3.4	2134	3.0	280	34500	—	—	—	VF/VF 130/210_280	P100	BN100LA6	170	
3.5	1788	1.0	400	13800	—	—	—	W/VF 63/130_400	P90	BN90LA4	146	
3.5	1951	2.2	400	19500	—	—	—	W/VF 86/185_400	P90	BN90LA4	162	
3.9	1975	0.9	240	16000	—	—	—	VFR 150_240	P100	BN100LA6	152	
3.9	1975	1.4	240	19500	—	—	—	VFR 185_240	P100	BN100LA6	160	
3.9	1975	2.2	240	34500	—	—	—	VFR 210_240	P100	BN100LA6	168	
3.9	2048	2.8	240	52000	—	—	—	VFR 250_240	P100	BN100LA6	174	
4.1	2033	1.3	345	16000	—	—	—	W/VF 86/150_345	P90	BN90LA4	154	
4.7	1676	1.4	300	19500	—	—	—	VFR 185_300	P90	BN90LA4	160	
4.7	1768	1.5	300	16000	—	—	—	W/VF 86/150_300	P90	BN90LA4	154	
4.9	1726	1.1	192	16000	—	—	—	VFR 150_192	P100	BN100LA6	152	
5.0	1422	1.3	280	13800	—	—	—	W/VF 63/130_280	P90	BN90LA4	146	
5.0	1479	2.8	280	19500	—	—	—	W/VF 86/185_280	P90	BN90LA4	162	
5.2	1646	2.0	180	19500	—	—	—	VFR 185_180	P100	BN100LA6	160	
5.2	1481	3.3	180	34500	—	—	—	VFR 210_180	P100	BN100LA6	168	
5.6	1536	0.9	168	13800	—	—	—	VFR 130_168	P100	BN100LA6	144	
5.9	1414	1.1	240	16000	—	—	—	VFR 150_240	P90	BN90LA4	152	
5.9	1439	1.9	240	19500	—	—	—	VFR 185_240	P90	BN90LA4	160	
6.3	1440	1.8	225	16000	—	—	—	W/VF 86/150_225	P90	BN90LA4	154	
7.1	1300	2.0	200	16000	—	—	—	W/VF 86/150_200	P90	BN90LA4	154	
7.3	1190	1.0	192	13800	—	—	—	VFR 130_192	P90	BN90LA4	144	
7.3	1209	1.4	192	16000	—	—	—	VFR 150_192	P90	BN90LA4	152	
7.8	1189	2.5	180	19500	—	—	—	VFR 185_180	P90	BN90LA4	160	
8.4	1092	1.1	168	13800	—	—	—	VFR 130_168	P90	BN90LA4	144	
8.4	1109	1.6	168	16000	—	—	—	VFR 150_168	P90	BN90LA4	152	
9.4	930	1.2	100	15500	—	—	—	VF 150_100	P100	BN100LA6	150	
9.4	945	2.1	100	19500	—	—	—	VF 185_100	P100	BN100LA6	158	
9.4	1021	3.2	150	16000	—	—	—	VFR 185_150	P90	BN90LA4	160	
10.2	939	1.4	138	13800	—	—	—	VFR 130_138	P90	BN90LA4	144	
10.2	953	2.1	138	16000	—	—	—	VFR 150_138	P90	BN90LA4	152	
10.4	905	1.0	90	8000	—	—	—	WR 110_90	P100	BN100LA6	140	
10.4	1001	3.2	90	19500	—	—	—	VFR 185_90	P100	BN100LA6	160	
11.8	829	1.0	120	8000	—	—	—	WR 110_120	P90	BN90LA4	140	
11.8	780	1.2	80	13200	—	—	—	VF 130_80	P100	BN100LA6	142	
11.8	792	1.7	80	15500	—	—	—	VF 150_80	P100	BN100LA6	150	
11.8	817	1.7	120	13800	—	—	—	VFR 130_120	P90	BN90LA4	144	
11.8	829	2.4	120	16000	—	—	—	VFR 150_120	P90	BN90LA4	152	
11.8	805	3.0	80	19000	—	—	—	VF 185_80	P100	BN100LA6	158	
13.6	789	1.0	69	8000	—	—	—	WR 110_69	P100	BN100LA6	140	
13.6	778	1.9	69	13800	—	—	—	VFR 130_69	P100	BN100LA6	144	
13.6	778	2.6	69	16000	—	—	—	VFR 150_69	P100	BN100LA6	152	
14.7	673	2.2	64	15500	—	—	—	VF 150_64	P100	BN100LA6	150	
15.7	640	1.3	90	8000	—	—	—	WR 110_90	P90	BN90LA4	140	
15.7	649	2.3	90	13800	—	—	—	VFR 130_90	P90	BN90LA4	144	
15.7	658	3.0	90	16000	—	—	—	VFR 150_90	P90	BN90LA4	152	
16.8	580	1.1	56	8000	W 110_56	S3	M3LA6	138	W 110_56	P100	BN100LA6	139
16.8	597	1.8	56	13200	—	—	—	VF 130_56	P100	BN100LA6	142	
16.8	606	2.5	56	15500	—	—	—	VF 150_56	P100	BN100LA6	150	
17.6	553	1.6	80	12600	—	—	—	VF 130_80	P90	BN90LA4	142	
20.4	540	1.2	69	8000	—	—	—	WR 110_69	P90	BN90LA4	140	
20.4	498	1.3	46	8000	W 110_46	S3	M3LA6	138	W 110_46	P100	BN100LA6	139
20.4	533	2.4	69	13800	—	—	—	VFR 130_69	P90	BN90LA4	144	
20.4	519	3.4	46	15500	—	—	—	VF 150_46	P100	BN100LA6	150	
20.4	540	3.4	69	16000	—	—	—	VFR 150_69	P90	BN90LA4	152	
22.0	455	1.2	64	8000	W 110_64	S3	M3SA4	138	W 110_64	P90	BN90LA4	139
22.0	462	2.0	64	12600	—	—	—	VF 130_64	P90	BN90LA4	142	



1.5 kW







n ₂ min ⁻¹	M ₂ Nm	S	i	Rn ₂ N						IEC 		
23.5	482	1.4	60	8000	—	—	—	WR 110_60	P90	BN90LA4	140	
23.5	445	2.7	40	13200	—	—	—	VF 130_40	P100	BN100LA6	142	
23.5	475	2.8	60	13800	—	—	—	VFR 130_60	P90	BN90LA4	144	
25.2	410	1.5	56	8000	W 110_56	S3	M3SA4	138	W 110_56	P90	BN90LA4	139
25.2	415	2.3	56	12600	—	—	—	VF 130_56	P90	BN90LA4	142	
31	341	1.0	46	7000	W 86_46	S3	M3SA4	134	W 86_46	P90	BN90LA4	135
31	346	1.7	46	8000	W 110_46	S3	M3SA4	138	W 110_46	P90	BN90LA4	139
31	355	3.0	46	12600	—	—	—	VF 130_46	P90	BN90LA4	142	
31	357	1.1	45	7000	—	—	—	WR 86_45	P90	BN90LA4	136	
31	366	1.9	45	8000	—	—	—	WR 110_45	P90	BN90LA4	140	
35	305	1.1	40	7000	W 86_40	S3	M3SA4	134	W 86_40	P90	BN90LA4	135
35	309	2.2	40	8000	W 110_40	S3	M3SA4	138	W 110_40	P90	BN90LA4	139
38	293	0.9	37.5	4330	—	—	—	WR 75_37.5	P90	BN90LA4	132	
38	293	0.9	25	4330	W 75_25	S3	M3LA6	130	W 75_25	P100	BN100LA6	131
41	280	1.2	34.5	7000	—	—	—	WR 86_34.5	P90	BN90LA4	136	
41	280	1.2	23	7000	W 86_23	S3	M3LA6	134	W 86_23	P100	BN100LA6	135
47	256	1.1	30	4130	—	—	—	WR 75_30	P90	BN90LA4	132	
47	235	1.2	30	4270	W 75_30	S3	M3SA4	130	W 75_30	P90	BN90LA4	131
47	250	1.4	30	7000	—	—	—	WR 86_30	P90	BN90LA4	136	
47	232	1.6	30	7000	W 86_30	S3	M3SA4	134	W 86_30	P90	BN90LA4	135
47	235	3.0	30	8000	W 110_30	S3	M3SA4	138	W 110_30	P90	BN90LA4	139
56	203	1.2	25	4100	W 75_25	S3	M3SA4	130	W 75_25	P90	BN90LA4	131
61	192	1.7	23	7000	W 86_23	S3	M3SA4	134	W 86_23	P90	BN90LA4	135
61	194	2.8	23	8000	W 110_23	S3	M3SA4	138	W 110_23	P90	BN90LA4	139
71	169	1.5	20	3880	W 75_20	S3	M3SA4	130	W 75_20	P90	BN90LA4	131
71	171	1.9	20	7000	W 86_20	S3	M3SA4	134	W 86_20	P90	BN90LA4	135
71	171	3.3	20	8000	W 110_20	S3	M3SA4	138	W 110_20	P90	BN90LA4	139
74	156	1.0	19	2550	—	—	—	W 63_19	P90	BN90LA4	126	
94	126	1.2	15	2450	—	—	—	W 63_15	P90	BN90LA4	126	
94	130	1.9	15	3630	W 75_15	S3	M3SA4	130	W 75_15	P90	BN90LA4	131
94	131	2.4	15	6520	—	—	—	WR 86_15	P90	BN90LA4	136	
94	130	2.5	15	6610	W 86_15	S3	M3SA4	134	W 86_15	P90	BN90LA4	135
118	104	1.4	12	2340	—	—	—	W 63_12	P90	BN90LA4	126	
134	94	2.2	7	3150	W 75_7	S3	M3LA6	130	W 75_7	P100	BN100LA6	131
141	87	1.6	10	2250	—	—	—	W 63_10	P90	BN90LA4	126	
141	89	2.6	10	3250	W 75_10	S3	M3SA4	130	W 75_10	P90	BN90LA4	131
141	89	3.2	10	5850	W 86_10	S3	M3SA4	134	W 86_10	P90	BN90LA4	135
187	66	1.9	15	2200	W 63_15	S2	M2SB2	126	W 63_15	P90	BN90SA2	127
187	68	3.3	15	3120	W 75_15	S2	M2SB2	130	W 75_15	P90	BN90SA2	131
201	63	1.9	7	2060	—	—	—	W 63_7	P90	BN90LA4	126	
201	64	3.0	7	2920	W 75_7	S3	M3SA4	130	W 75_7	P90	BN90LA4	131
201	63	3.9	7	5240	W 86_7	S3	M3SA4	134	W 86_7	P90	BN90LA4	135
233	53	2.3	12	2080	W 63_12	S2	M2SB2	126	W 63_12	P90	BN90SA2	127
280	45	2.8	10	1980	W 63_10	S2	M2SB2	126	W 63_10	P90	BN90SA2	127

1.85 kW

n ₂ min ⁻¹	M ₂ Nm	S	i	Rn ₂ N						IEC 	
0.44	8480	1.1	3200	52000	—	—	—	VF/VF 130/250_3200	P90	BN90LB4	176
0.55	8077	1.1	2560	52000	—	—	—	VF/VF 130/250_2560	P90	BN90LB4	176
0.76	7198	1.3	1840	52000	—	—	—	VF/VF 130/250_1840	P90	BN90LB4	176
1.0	6117	1.1	920	34500	—	—	—	VF/VF 130/210_920	P100	BN100LB6	170
1.0	6117	1.5	920	52000	—	—	—	VF/VF 130/250_920	P100	BN100LB6	176
1.2	5775	1.1	800	34500	—	—	—	VF/VF 130/210_800	P100	BN100LB6	170
1.2	6079	1.5	800	52000	—	—	—	VF/VF 130/250_800	P100	BN100LB6	176
1.6	4901	1.3	600	34500	—	—	—	VF/VF 130/210_600	P100	BN100LB6	170
1.6	4901	1.9	600	52000	—	—	—	VF/VF 130/250_600	P100	BN100LB6	176
1.8	4341	1.0	800	19500	—	—	—	W/VF 86/185_800	P90	BN90LB4	162
2.3	3647	1.8	400	34500	—	—	—	VF/VF 130/210_400	P100	BN100LB6	170
2.3	3571	2.6	400	52000	—	—	—	VF/VF 130/250_400	P100	BN100LB6	176
2.3	3407	1.2	600	19500	—	—	—	W/VF 86/185_600	P90	BN90LB4	162









1.85 kW







n ₂ min ⁻¹	M ₂ Nm	S	i	R _{n2} N						IEC 		
3.1	2793	1.3	300	34500	—	—	—	VFR 210_300	P100	BN100LB6	168	
3.1	2964	1.8	300	52000	—	—	—	VFR 250_300	P100	BN100LB6	174	
3.3	2660	2.4	280	34500	—	—	—	VF/VF 130/210_280	P100	BN100LB6	170	
3.3	2713	3.4	280	52000	—	—	—	VF/VF 130/250_280	P100	BN100LB6	176	
3.5	2423	1.7	400	19500	—	—	—	W/VF 86/185_400	P90	BN90LB4	162	
3.9	2462	1.1	240	19500	—	—	—	VFR 185_240	P100	BN100LB6	160	
3.9	2462	1.8	240	34500	—	—	—	VFR 210_240	P100	BN100LB6	168	
3.9	2553	2.3	240	52000	—	—	—	VFR 250_240	P100	BN100LB6	174	
4.1	2525	1.0	345	16000	—	—	—	W/VF 86/150_345	P90	BN90LB4	154	
4.7	2082	1.1	300	19500	—	—	—	VFR 185_300	P90	BN90LB4	160	
4.7	2196	1.2	300	16000	—	—	—	W/VF 86/150_300	P90	BN90LB4	154	
4.8	2152	0.9	192	16000	—	—	—	VFR 150_192	P100	BN100LB6	152	
5.0	1767	1.0	280	13800	—	—	—	W/VF 63/130_280	P90	BN90LB4	146	
5.0	1837	2.3	280	19500	—	—	—	W/VF 86/185_280	P90	BN90LB4	162	
5.2	2052	1.6	180	19500	—	—	—	VFR 185_180	P100	BN100LB6	160	
5.2	1847	2.7	180	34500	—	—	—	VFR 210_180	P100	BN100LB6	168	
5.2	2120	3.2	180	52000	—	—	—	VFR 250_180	P100	BN100LB6	174	
5.8	1757	0.9	240	16000	—	—	—	VFR 150_240	P90	BN90LB4	152	
5.8	1787	1.6	240	19500	—	—	—	VFR 185_240	P90	BN90LB4	160	
6.2	1767	3.0	150	34500	—	—	—	VFR 210_150	P100	BN100LB6	168	
6.2	1789	1.5	225	16000	—	—	—	W/VF 86/150_225	P90	BN90LB4	154	
6.7	1678	0.9	138	13800	—	—	—	VFR 130_138	P100	BN100LB6	144	
6.7	1678	1.3	138	16000	—	—	—	VFR 150_138	P100	BN100LB6	152	
7.0	1615	1.6	200	16000	—	—	—	W/VF 86/150_200	P90	BN90LB4	154	
7.3	1502	1.1	192	16000	—	—	—	VFR 150_192	P90	BN90LB4	152	
7.8	1476	2.0	180	19500	—	—	—	VFR 185_180	P90	BN90LB4	160	
8.3	1357	0.9	168	13800	—	—	—	VFR 130_168	P90	BN90LB4	144	
8.3	1378	1.3	168	16000	—	—	—	VFR 150_168	P90	BN90LB4	152	
9.3	1159	1.0	100	15500	—	—	—	VF 150_100	P100	BN100LB6	150	
9.3	1178	1.7	100	19000	—	—	—	VF 185_100	P100	BN100LB6	158	
9.3	1268	2.6	150	19500	—	—	—	VFR 185_150	P90	BN90LB4	160	
10.1	1167	1.2	138	13800	—	—	—	VFR 130_138	P90	BN90LB4	144	
10.1	1184	1.7	138	16000	—	—	—	VFR 150_138	P90	BN90LB4	152	
11.6	973	1.0	80	13200	—	—	—	VF 130_80	P100	BN100LB6	142	
11.6	988	1.4	80	15500	—	—	—	VF 150_80	P100	BN100LB6	150	
11.6	1003	2.4	80	19000	—	—	—	VF 185_80	P100	BN100LB6	158	
11.7	1015	1.4	120	13800	—	—	—	VFR 130_120	P90	BN90LB4	144	
11.7	1030	1.9	120	16000	—	—	—	VFR 150_120	P90	BN90LB4	152	
11.7	1060	3.4	120	19500	—	—	—	VFR 185_120	P90	BN90LB4	160	
13.5	970	1.5	69	13800	—	—	—	VFR 130_69	P100	BN100LB6	144	
13.5	970	2.1	69	16000	—	—	—	VFR 150_69	P100	BN100LB6	152	
14.5	839	1.7	64	15500	—	—	—	VF 150_64	P100	BN100LB6	150	
15.6	795	1.0	90	8000	—	—	—	WR 110_90	P90	BN90LB4	140	
15.6	806	1.9	90	13800	—	—	—	VFR 130_90	P90	BN90LB4	144	
15.6	818	2.4	90	16000	—	—	—	VFR 150_90	P90	BN90LB4	152	
15.6	863	3.2	90	19500	—	—	—	VFR 185_90	P90	BN90LB4	160	
16.6	755	2.0	56	15500	—	—	—	VF 150_56	P100	BN100LB6	150	
17.5	687	1.3	80	12600	—	—	—	VF 130_80	P90	BN90LB4	142	
20.2	647	2.7	46	15500	—	—	—	VF 150_46	P100	BN100LB6	150	
20.3	670	1.0	69	8000	—	—	—	WR 110_69	P90	BN90LB4	140	
20.3	662	2.0	69	13800	—	—	—	VFR 130_69	P90	BN90LB4	144	
20.3	670	2.8	69	16000	—	—	—	VFR 150_69	P90	BN90LB4	152	
21.9	565	0.9	64	8000	—	—	—	W 110_64	P90	BN90LB4	138	
21.9	573	1.6	64	12600	—	—	—	VF 130_64	P90	BN90LB4	142	
23.3	555	1.3	40	8000	W 110_40	S3	M3LB6	138	W 110_40	P100	BN100LB6	139
23.3	562	3.1	40	15500	—	—	—	VF 150_40	P100	BN100LB6	150	
23.3	598	1.1	60	8000	—	—	—	WR 110_60	P90	BN90LB4	140	
23.3	591	2.3	60	13800	—	—	—	VFR 130_60	P90	BN90LB4	144	
23.3	598	3.2	60	16000	—	—	—	VFR 150_60	P90	BN90LB4	152	
25.0	509	1.2	56	8000	—	—	—	W 110_56	P90	BN90LB4	138	
25.0	516	1.9	56	12600	—	—	—	VF 130_56	P90	BN90LB4	142	
30	430	1.4	46	8000	—	—	—	W 110_46	P90	BN90LB4	138	
30	441	2.4	46	12600	—	—	—	VF 130_46	P90	BN90LB4	142	
31	416	1.0	30	7000	W 86_30	S3	M3LB6	134	W 86_30	P100	BN100LB6	135
31	443	0.9	45	7000	—	—	—	WR 86_45	P90	BN90LB4	136	



1.85 kW





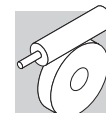

n ₂ min ⁻¹	M ₂ Nm	S	i	R _{n2} N						IEC 		
31	454	1.6	45	8000	—	—	—	WR 110_45	P90	BN90LB4	140	
35	384	1.7	40	8000	—	—	—	W 110_40	P90	BN90LB4	138	
40	350	1.0	23	7000	W 86_23	S3	M3LB6	134	W 86_23	P100	BN100LB6	135
40	354	3.0	23	13200	—	—	—	VF 130_23	P100	BN100LB6	142	
41	348	1.0	34.5	7000	—	—	—	WR 86_34.5	P90	BN90LB4	136	
42	339	3.1	69	13800	—	—	—	VFR 130_69	P90	BN90SB2	144	
47	308	1.1	20	7000	W 86_20	S3	M3LB6	134	W 86_20	P100	BN100LB6	135
47	312	3.4	20	13200	—	—	—	VF 130_20	P100	BN100LB6	142	
47	292	0.9	30	3960	—	—	—	W 75_30	P90	BN90LB4	130	
47	310	1.1	30	7000	—	—	—	WR 86_30	P90	BN90LB4	136	
47	288	1.3	30	7000	—	—	—	W 86_30	P90	BN90LB4	134	
47	318	2.1	30	8000	—	—	—	WR 110_30	P90	BN90LB4	140	
47	292	2.4	30	8000	—	—	—	W 110_30	P90	BN90LB4	138	
56	252	1.0	25	3820	—	—	—	W 75_25	P90	BN90LB4	130	
61	238	1.3	23	7000	—	—	—	W 86_23	P90	BN90LB4	134	
61	241	2.2	23	8000	—	—	—	W 110_23	P90	BN90LB4	138	
62	237	1.1	15	3600	W 75_15	S3	M3LB6	130	W 75_15	P100	BN100LB6	131
62	234	1.5	15	7000	W 86_15	S3	M3LB6	134	W 86_15	P100	BN100LB6	135
67	228	2.6	21	8000	—	—	—	WR 110_21	P90	BN90LB4	140	
70	209	1.2	20	3650	—	—	—	W 75_20	P90	BN90LB4	130	
70	212	1.5	20	6960	—	—	—	W 86_20	P90	BN90LB4	134	
70	212	2.7	20	8000	—	—	—	W 110_20	P90	BN90LB4	138	
93	163	1.5	10	3280	W 75_10	S3	M3LB6	130	W 75_10	P100	BN100LB6	131
93	157	1.0	15	2230	—	—	—	W 63_15	P90	BN90LB4	126	
93	161	1.6	15	3440	—	—	—	W 75_15	P90	BN90LB4	130	
93	161	2.1	15	6450	—	—	—	W 86_15	P90	BN90LB4	134	
117	129	1.1	12	2150	—	—	—	W 63_12	P90	BN90LB4	126	
133	117	1.8	7	2970	W 75_7	S3	M3LB6	130	W 75_7	P100	BN100LB6	131
133	117	2.3	7	5700	W 86_7	S3	M3LB6	134	W 86_7	P100	BN100LB6	135
140	109	1.3	10	2090	—	—	—	W 63_10	P90	BN90LB4	126	
140	111	2.1	10	3100	—	—	—	W 75_10	P90	BN90LB4	130	
140	111	2.6	10	5730	—	—	—	W 86_10	P90	BN90LB4	134	
192	79	1.6	15	2080	—	—	—	W 63_15	P90	BN90SB2	126	
192	81	2.8	15	3000	—	—	—	W 75_15	P90	BN90SB2	130	
200	78	1.5	7	1930	—	—	—	W 63_7	P90	BN90LB4	126	
200	80	2.4	7	2790	—	—	—	W 75_7	P90	BN90LB4	130	
200	79	3.2	7	5140	—	—	—	W 86_7	P90	BN90LB4	134	
240	64	2.0	12	1980	—	—	—	W 63_12	P90	BN90SB2	126	
288	54	2.3	10	1890	—	—	—	W 63_10	P90	BN90SB2	126	
288	55	3.7	10	2670	—	—	—	W 75_10	P90	BN90SB2	130	
411	39	2.7	7	1720	—	—	—	W 63_7	P90	BN90SB2	126	

2.2 kW

n ₂ min ⁻¹	M ₂ Nm	S	i	R _{n2} N						IEC 	
0.44	10013	0.9	3200	52000	—	—	—	VF/VF 130/250_3200	P100	BN100LA4	176
0.55	9536	0.9	2560	52000	—	—	—	VF/VF 130/250_2560	P100	BN100LA4	176
0.77	8499	1.1	1840	52000	—	—	—	VF/VF 130/250_1840	P100	BN100LA4	176
0.88	7629	1.2	1600	52000	—	—	—	VF/VF 130/250_1600	P100	BN100LA4	176
1.0	7197	0.9	920	34500	—	—	—	VF/VF 130/210_920	P112	BN112M6	170
1.0	7197	1.3	920	52000	—	—	—	VF/VF 130/250_920	P112	BN112M6	176
1.2	6258	1.0	1200	34500	—	—	—	VF/VF 130/210_1200	P100	BN100LA4	170
1.2	6258	1.4	1200	52000	—	—	—	VF/VF 130/250_1200	P100	BN100LA4	176
1.5	5072	1.2	920	34500	—	—	—	VF/VF 130/210_920	P100	BN100LA4	170
1.5	5072	1.8	920	52000	—	—	—	VF/VF 130/250_920	P100	BN100LA4	176
1.8	4887	1.3	800	34500	—	—	—	VF/VF 130/210_800	P100	BN100LA4	170
1.8	5007	1.8	800	52000	—	—	—	VF/VF 130/250_800	P100	BN100LA4	176
2.4	4023	1.0	600	19500	—	—	—	W/VF 86/185_600	P100	BN100LA4	162
2.4	3844	1.6	600	34500	—	—	—	VF/VF 130/210_600	P100	BN100LA4	170
2.4	3934	2.3	600	52000	—	—	—	VF/VF 130/250_600	P100	BN100LA4	176
3.1	3286	1.1	300	34500	—	—	—	VFR 210_300	P112	BN112M6	168









2.2 kW







n ₂ min ⁻¹	M ₂ Nm	S	i	R _{n2} N						IEC 		
3.1	3487	1.5	300	52000	—	—	—	VFR 250_300	P112	BN112M6	174	
3.5	2861	1.5	400	19500	—	—	—	W/VF 86/185_400	P100	BN100LA4	162	
3.5	2980	2.1	400	34500	—	—	—	VF/VF 130/210_400	P100	BN100LA4	170	
3.5	2921	3.1	400	52000	—	—	—	VF/VF 130/250_400	P100	BN100LA4	176	
3.9	2897	1.0	240	19500	—	—	—	VFR 185_240	P112	BN112M6	160	
3.9	2897	1.5	240	34500	—	—	—	VFR 210_240	P112	BN112M6	168	
3.9	3004	1.9	240	52000	—	—	—	VFR 250_240	P112	BN112M6	174	
4.7	2459	0.9	300	19500	—	—	—	VFR 185_300	P100	BN100LA4	160	
4.7	2459	1.4	300	34500	—	—	—	VFR 210_300	P100	BN100LA4	168	
4.7	2548	2.0	300	52000	—	—	—	VFR 250_300	P100	BN100LA4	174	
5.0	2170	1.9	280	19500	—	—	—	W/VF 86/185_280	P100	BN100LA4	162	
5.0	2170	2.9	280	34500	—	—	—	VF/VF 130/210_280	P100	BN100LA4	170	
5.6	2291	0.9	168	16000	—	—	—	VFR 150_168	P112	BN112M6	152	
5.9	2110	1.3	240	19500	—	—	—	VFR 185_240	P100	BN100LA4	160	
5.9	2110	1.8	240	34500	—	—	—	VFR 210_240	P100	BN100LA4	168	
5.9	2181	2.5	240	52000	—	—	—	VFR 250_240	P100	BN100LA4	174	
7.3	1774	1.0	192	16000	—	—	—	VFR 150_192	P100	BN100LA4	152	
7.8	1690	0.9	120	13800	—	—	—	VFR 130_120	P112	BN112M6	144	
7.8	1743	1.7	180	19500	—	—	—	VFR 185_180	P100	BN100LA4	160	
7.8	1717	2.5	180	34500	—	—	—	VFR 210_180	P100	BN100LA4	168	
7.8	1797	3.5	180	52000	—	—	—	VFR 250_180	P100	BN100LA4	174	
8.4	1627	1.1	168	16000	—	—	—	VFR 150_168	P100	BN100LA4	152	
9.4	1386	1.4	100	19000	—	—	—	VF 185_100	P112	BN112M6	158	
9.4	1498	2.2	150	19500	—	—	—	VFR 185_150	P100	BN100LA4	160	
9.4	1498	3.0	150	34500	—	—	—	VFR 210_150	P100	BN100LA4	168	
10.2	1378	1.0	138	13800	—	—	—	VFR 130_138	P100	BN100LA4	144	
10.2	1398	1.4	138	16000	—	—	—	VFR 150_138	P100	BN100LA4	152	
10.4	1468	2.2	90	19500	—	—	—	VFR 185_90	P112	BN112M6	160	
10.4	1448	3.2	90	34500	—	—	—	VFR 210_90	P112	BN112M6	168	
11.8	1162	1.2	80	15500	—	—	—	VF 150_80	P112	BN112M6	150	
11.8	1198	1.2	120	13800	—	—	—	VFR 130_120	P100	BN100LA4	144	
11.8	1216	1.6	120	16000	—	—	—	VFR 150_120	P100	BN100LA4	152	
11.8	1180	2.0	80	19000	—	—	—	VF 185_80	P112	BN112M6	158	
11.8	1252	2.9	120	19500	—	—	—	VFR 185_120	P100	BN100LA4	160	
11.8	1252	4.0	120	34500	—	—	—	VFR 210_120	P100	BN100LA4	168	
13.6	1141	1.3	69	13800	—	—	—	VFR 130_69	P112	BN112M6	144	
13.6	1141	1.8	69	16000	—	—	—	VFR 150_69	P112	BN112M6	152	
14.1	969	1.2	100	14700	—	—	—	VF 150_100	P100	BN100LA4	150	
14.1	969	2.0	100	18000	—	—	—	VF 185_100	P100	BN100LA4	158	
14.7	973	1.1	64	13200	—	—	—	VF 130_64	P112	BN112M6	142	
15.7	952	1.6	90	13800	—	—	—	VFR 130_90	P100	BN100LA4	144	
15.7	966	2.0	90	16000	—	—	—	VFR 150_90	P100	BN100LA4	152	
15.7	952	2.7	60	19000	—	—	—	VF 185_60	P112	BN112M6	158	
15.7	1019	2.7	90	19500	—	—	—	VFR 185_90	P100	BN100LA4	160	
16.8	876	1.2	56	13200	—	—	—	VF 130_56	P112	BN112M6	142	
17.6	811	1.1	80	12600	—	—	—	VF 130_80	P100	BN100LA4	142	
17.6	823	1.5	80	14700	—	—	—	VF 150_80	P100	BN100LA4	150	
17.6	823	2.6	80	18000	—	—	—	VF 185_80	P100	BN100LA4	158	
20.4	751	1.5	46	13200	—	—	—	VF 130_46	P112	BN112M6	142	
20.4	781	1.7	69	13800	—	—	—	VFR 130_69	P100	BN100LA4	144	
20.4	761	2.3	46	15500	—	—	—	VF 150_46	P112	BN112M6	150	
20.4	792	2.3	69	16000	—	—	—	VFR 150_69	P100	BN100LA4	152	
20.9	774	1.1	45	8000	—	—	—	WR 110_45	P112	BN112M6	140	
22.0	677	1.4	64	12600	—	—	—	VF 130_64	P100	BN100LA4	142	
22.0	687	1.9	64	14700	—	—	—	VF 150_64	P100	BN100LA4	150	
23.3	660	1.1	40	8000	W 110_40	S3	M3LC6	138	W 110_40	P112	BN112M6	139
23.5	706	1.0	60	8000	—	—	—	—	WR 110_60	P100	BN100LA4	140
23.5	697	1.9	60	13800	—	—	—	—	VFR 130_60	P100	BN100LA4	144
23.5	706	2.7	60	16000	—	—	—	—	VFR 150_60	P100	BN100LA4	152
23.5	662	3.4	60	18000	—	—	—	—	VF 185_60	P100	BN100LA4	158
25.2	601	1.0	56	8000	W 110_56	S3	M3LA4	138	W 110_56	P100	BN100LA4	139
25.2	609	1.6	56	12600	—	—	—	—	VF 130_56	P100	BN100LA4	142
25.2	617	2.2	56	14200	—	—	—	—	VF 150_56	P100	BN100LA4	150
31	507	1.2	46	8000	W 110_46	S3	M3LA4	138	W 110_46	P100	BN100LA4	139
31	521	2.0	46	12600	—	—	—	—	VF 130_46	P100	BN100LA4	142



2.2 kW

n ₂ min ⁻¹	M ₂ Nm	S	i	R _{n2} N						IEC 	
31	528	2.9	46	14700	—	—	—	—	VF 150_46	P100 BN100LA4	150
31	536	1.3	45	8000	—	—	—	—	WR 110_45	P100 BN100LA4	140
31	550	3.1	45	16000	—	—	—	—	VFR 150_45	P100 BN100LA4	152
35	453	1.5	40	8000	W 110_40	S3 M3LA4	138	—	W 110_40	P100 BN100LA4	139
35	453	2.4	40	12600	—	—	—	—	VF 130_40	P100 BN100LA4	142
35	459	3.4	40	14700	—	—	—	—	VF 150_40	P100 BN100LA4	150
41	416	2.5	23	13200	—	—	—	—	VF 130_23	P112 BN112M6	142
47	340	1.1	30	7000	W 86_30	S3 M3LA4	134	—	W 86_30	P100 BN100LA4	135
47	344	2.0	30	8000	W 110_30	S3 M3LA4	138	—	W 110_30	P100 BN100LA4	139
47	353	3.0	30	12600	—	—	—	—	VF 130_30	P100 BN100LA4	142
61	281	1.1	23	6990	W 86_23	S3 M3LA4	134	—	W 86_23	P100 BN100LA4	135
61	284	1.9	23	8000	W 110_23	S3 M3LA4	138	—	W 110_23	P100 BN100LA4	139
61	284	3.1	23	12600	—	—	—	—	VF 130_23	P100 BN100LA4	142
71	247	1.0	20	3410	W 75_20	S3 M3LA4	130	—	W 75_20	P100 BN100LA4	131
71	250	1.3	20	6730	W 86_20	S3 M3LA4	134	—	W 86_20	P100 BN100LA4	135
71	250	2.3	20	8000	W 110_20	S3 M3LA4	138	—	W 110_20	P100 BN100LA4	139
94	190	1.3	15	3240	W 75_15	S3 M3LA4	130	—	W 75_15	P100 BN100LA4	131
94	190	1.7	15	6270	W 86_15	S3 M3LA4	134	—	W 86_15	P100 BN100LA4	135
94	188	3.2	15	8000	W 110_15	S3 M3LA4	138	—	W 110_15	P100 BN100LA4	139
133	139	1.5	7	2780	W 75_7	S3 M3LC6	130	—	W 75_7	P112 BN112M6	131
133	139	1.9	7	5540	W 86_7	S3 M3LC6	134	—	W 86_7	P112 BN112M6	135
141	131	1.8	10	2940	W 75_10	S3 M3LA4	130	—	W 75_10	P100 BN100LA4	131
141	131	2.2	10	5590	W 86_10	S3 M3LA4	134	—	W 86_10	P100 BN100LA4	135
187	99	2.3	15	2920	W 75_15	S3 M3SA2	130	—	W 75_15	P90 BN90L2	131
187	98	3.0	15	5290	W 86_15	S3 M3SA2	134	—	W 86_15	P90 BN90L2	135
192	94	1.3	15	1980	—	—	—	—	W 63_15	P90 BN90L2	126
201	94	2.0	7	2660	W 75_7	S3 M3LA4	130	—	W 75_7	P100 BN100LA4	131
201	93	2.7	7	5030	W 86_7	S3 M3LA4	134	—	W 86_7	P100 BN100LA4	135
240	76	1.6	12	1890	—	—	—	—	W 63_12	P90 BN90L2	126
281	67	3.0	10	2610	W 75_10	S3 M3SA2	130	—	W 75_10	P90 BN90L2	131
288	64	1.9	10	1820	—	—	—	—	W 63_10	P90 BN90L2	126
401	48	3.6	7	2350	W 75_7	S3 M3SA2	130	—	W 75_7	P90 BN90L2	131
411	46	2.3	7	1660	—	—	—	—	W 63_7	P90 BN90L2	126

3 kW

n ₂ min ⁻¹	M ₂ Nm	S	i	R _{n2} N						IEC 	
0.88	10403	0.9	1600	52000	—	—	—	—	VF/VF 130/250_1600	P100 BN100LB4	176
1.0	9814	0.9	920	52000	—	—	—	—	VF/VF 130/250_920	P132 BN132S6	176
1.2	8534	1.1	1200	52000	—	—	—	—	VF/VF 130/250_1200	P100 BN100LB4	176
1.5	6917	0.9	920	34500	—	—	—	—	VF/VF 130/210_920	P100 BN100LB4	170
1.5	6917	1.3	920	52000	—	—	—	—	VF/VF 130/250_920	P100 BN100LB4	176
1.8	6665	0.9	800	34500	—	—	—	—	VF/VF 130/210_800	P100 BN100LB4	170
1.8	6827	1.3	800	52000	—	—	—	—	VF/VF 130/250_800	P100 BN100LB4	176
2.4	5242	1.2	600	34500	—	—	—	—	VF/VF 130/210_600	P100 BN100LB4	170
2.4	5364	1.7	600	52000	—	—	—	—	VF/VF 130/250_600	P100 BN100LB4	176
3.1	4755	1.1	300	52000	—	—	—	—	VFR 250_300	P132 BN132S6	174
3.5	3901	1.1	400	19500	—	—	—	—	W /VF 86/185_400	P100 BN100LB4	162
3.5	4064	1.6	400	34500	—	—	—	—	VF/VF 130/210_400	P100 BN100LB4	170
3.5	3983	2.3	400	52000	—	—	—	—	VF/VF 130/250_400	P100 BN100LB4	176
3.9	3950	1.1	240	34500	—	—	—	—	VFR 210_240	P132 BN132S6	168
3.9	4096	1.4	240	52000	—	—	—	—	VFR 250_240	P132 BN132S6	174
4.7	3353	1.0	300	34500	—	—	—	—	VFR 210_300	P100 BN100LB4	168
4.7	3475	1.4	300	52000	—	—	—	—	VFR 250_300	P100 BN100LB4	174
5.0	2958	1.4	280	19500	—	—	—	—	W /VF 86/185_280	P100 BN100LB4	162
5.0	2958	2.1	280	34500	—	—	—	—	VF/VF 130/210_280	P100 BN100LB4	170
5.0	3015	3.0	280	52000	—	—	—	—	VF/VF 130/250_280	P100 BN100LB4	176
5.9	2877	1.0	240	19500	—	—	—	—	VFR 185_240	P100 BN100LB4	160
5.9	2877	1.4	240	34500	—	—	—	—	VFR 210_240	P100 BN100LB4	168
5.9	2975	1.8	240	52000	—	—	—	—	VFR 250_240	P100 BN100LB4	174
7.8	2377	1.3	180	19500	—	—	—	—	VFR 185_180	P100 BN100LB4	160

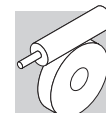

3 kW

n ₂ min-1	M ₂ Nm	S	i	Rn ₂ N						IEC		
7.8	2341	1.8	180	34500	—	—	—	VFR 210_180	P100	BN100LB4	168	
7.8	2450	2.6	180	52000	—	—	—	VFR 250_180	P100	BN100LB4	174	
9.4	1859	1.6	100	33000	—	—	—	VF 210_100	P132	BN132S6	166	
9.4	2042	1.6	150	19500	—	—	—	VFR 185_150	P100	BN100LB4	160	
9.4	2042	2.2	150	34500	—	—	—	VFR 210_150	P100	BN100LB4	168	
9.4	1920	2.5	100	50000	—	—	—	VF 250_100	P132	BN132S6	172	
9.4	2042	3.2	150	52000	—	—	—	VFR 250_150	P100	BN100LB4	174	
10.2	1907	1.0	138	16000	—	—	—	VFR 150_138	P100	BN100LB4	152	
11.8	1634	0.9	120	13800	—	—	—	VFR 130_120	P100	BN100LB4	144	
11.8	1658	1.2	120	16000	—	—	—	VFR 150_120	P100	BN100LB4	152	
11.8	1609	1.5	80	19000	—	—	—	VF 185_80	P132	BN132S6	158	
11.8	1585	2.1	80	33000	—	—	—	VF 210_80	P132	BN132S6	166	
11.8	1707	2.1	120	19500	—	—	—	VFR 185_120	P100	BN100LB4	160	
11.8	1707	2.9	120	34500	—	—	—	VFR 210_120	P100	BN100LB4	168	
11.8	1634	3.2	80	50000	—	—	—	VF 250_80	P132	BN132S6	172	
11.8	1731	4.0	120	52000	—	—	—	VFR 250_120	P100	BN100LB4	174	
14.1	1321	0.9	100	14700	—	—	—	VF 150_100	P100	BN100LB4	150	
14.1	1321	1.4	100	18000	—	—	—	VF 185_100	P100	BN100LB4	158	
15.7	1298	1.2	90	13800	—	—	—	VFR 130_90	P100	BN100LB4	144	
15.7	1317	1.5	90	16000	—	—	—	VFR 150_90	P100	BN100LB4	152	
15.7	1298	2.0	60	19000	—	—	—	VF 185_60	P132	BN132S6	158	
15.7	1390	2.0	90	19500	—	—	—	VFR 185_90	P100	BN100LB4	160	
15.7	1390	2.9	90	34500	—	—	—	VFR 210_90	P100	BN100LB4	168	
15.7	1280	2.9	60	33000	—	—	—	VF 210_60	P132	BN132S6	166	
17.6	1122	1.1	80	14700	—	—	—	VF 150_80	P100	BN100LB4	150	
17.6	1122	1.9	80	18000	—	—	—	VF 185_80	P100	BN100LB4	158	
20.4	1066	1.2	69	13800	—	—	—	VFR 130_69	P100	BN100LB4	144	
20.4	1080	1.7	69	16000	—	—	—	VFR 150_69	P100	BN100LB4	152	
22.0	923	1.0	64	12600	—	—	—	VF 130_64	P100	BN100LB4	142	
22.0	936	1.4	64	14700	—	—	—	VF 150_64	P100	BN100LB4	150	
23.5	951	1.4	60	13800	—	—	—	VFR 130_60	P100	BN100LB4	144	
23.5	963	2.0	60	16000	—	—	—	VFR 150_60	P100	BN100LB4	152	
23.5	902	2.5	60	18000	—	—	—	VF 185_60	P100	BN100LB4	158	
25.2	831	1.2	56	12600	—	—	—	VF 130_56	P100	BN100LB4	142	
25.2	842	1.6	56	14700	—	—	—	VF 150_56	P100	BN100LB4	150	
28.2	772	3.2	50	18000	—	—	—	VF 185_50	P100	BN100LB4	158	
31	710	1.5	46	12600	—	—	—	VF 130_46	P100	BN100LB4	142	
31	720	2.2	46	14700	—	—	—	VF 150_46	P100	BN100LB4	150	
31	731	1.0	45	8000	—	—	—	WR 110_45	P100	BN100LB4	140	
31	677	1.1	30	8000	—	—	—	W 110_30	P132	BN132S6	138	
31	750	2.3	45	16000	—	—	—	VFR 150_45	P100	BN100LB4	152	
31	741	3.2	30	19000	—	—	—	VF 185_30	P132	BN132S6	158	
35	618	1.1	40	8000	W 110_40	S3	M3LB4	138	W 110_40	P100	BN100LB4	139
35	618	1.8	40	12600	—	—	—	VF 130_40	P100	BN100LB4	142	
35	626	2.5	40	14700	—	—	—	VF 150_40	P100	BN100LB4	150	
41	568	1.0	23	8000	—	—	—	W 110_23	P132	BN132S6	138	
41	568	1.8	23	13200	—	—	—	VF 130_23	P132	BN132S6	142	
41	575	2.6	23	15500	—	—	—	VF 150_23	P132	BN132S6	150	
47	469	1.5	30	8000	W 110_30	S3	M3LB4	138	W 110_30	P100	BN100LB4	139
47	482	2.2	30	12600	—	—	—	VF 130_30	P100	BN100LB4	142	
47	488	2.8	30	14700	—	—	—	VF 150_30	P100	BN100LB4	150	
47	518	2.9	30	16000	—	—	—	VFR 150_30	P100	BN100LB4	152	
61	388	1.4	23	8000	W 110_23	S3	M3LB4	138	W 110_23	P100	BN100LB4	139
61	388	2.3	23	12600	—	—	—	VF 130_23	P100	BN100LB4	142	
61	388	3.3	23	14700	—	—	—	VF 150_23	P100	BN100LB4	150	
71	341	0.9	20	6240	W 86_20	S3	M3LB4	134	W 86_20	P100	BN100LB4	135
71	341	1.7	20	8000	W 110_20	S3	M3LB4	138	W 110_20	P100	BN100LB4	139
71	341	2.6	20	12600	—	—	—	VF 130_20	P100	BN100LB4	142	
94	259	1.0	15	2800	W 75_15	S3	M3LB4	130	W 75_15	P100	BN100LB4	131
94	259	1.3	15	5890	W 86_15	S3	M3LB4	134	W 86_15	P100	BN100LB4	135
94	256	2.3	15	8000	W 110_15	S3	M3LB4	138	W 110_15	P100	BN100LB4	139
94	262	3.5	15	11800	—	—	—	VF 130_15	P100	BN100LB4	142	
124	198	3.4	23	11000	—	—	—	VF 130_23	P100	BN100L2	142	
141	179	1.3	10	2600	W 75_10	S3	M3LB4	130	W 75_10	P100	BN100LB4	131
141	179	1.6	10	5300	W 86_10	S3	M3LB4	134	W 86_10	P100	BN100LB4	135



3 kW







n ₂ min ⁻¹	M ₂ Nm	S	i	Rn ₂ N						IEC		
141	177	3.1	10	8000	W 110_10	S3	M3LB4	138	W 110_10	P100	BN100LB4	139
191	132	1.7	15	2680	W 75_15	S3	M3LA2	130	W 75_15	P100	BN100L2	131
191	131	2.3	15	5070	W 86_15	S3	M3LA2	134	W 86_15	P100	BN100L2	135
201	128	1.5	7	2380	W 75_7	S3	M3LB4	130	W 75_7	P100	BN100LB4	131
201	127	2.0	7	4780	W 86_7	S3	M3LB4	134	W 86_7	P100	BN100LB4	135
286	90	2.3	10	2430	W 75_10	S3	M3LA2	130	W 75_10	P100	BN100L2	131
286	90	2.9	10	4510	W 86_10	S3	M3LA2	134	W 86_10	P100	BN100L2	135
409	64	2.7	7	2190	W 75_7	S3	M3LA2	130	W 75_7	P100	BN100L2	131
409	64	3.5	7	4040	W 86_7	S3	M3LA2	134	W 86_7	P100	BN100L2	135

4 kW







n ₂ min ⁻¹	M ₂ Nm	S	i	Rn ₂ N						IEC		
1.5	9157	1.0	920	52000	—	—	—	—	VF/VF 130/250_920	P112	BN112M4	176
1.8	9039	1.0	800	52000	—	—	—	—	VF/VF 130/250_800	P112	BN112M4	176
2.4	6941	0.9	600	34500	—	—	—	—	VF/VF 130/210_600	P112	BN112M4	170
2.4	7102	1.3	600	52000	—	—	—	—	VF/VF 130/250_600	P112	BN112M4	176
3.6	5380	1.2	400	34500	—	—	—	—	VF/VF 130/210_400	P112	BN112M4	170
3.6	5273	1.7	400	52000	—	—	—	—	VF/VF 130/250_400	P112	BN112M4	176
4.0	5404	1.1	240	52000	—	—	—	—	VFR 250_240	P132	BN132MA6	174
4.7	4600	1.1	300	52000	—	—	—	—	VFR 250_300	P112	BN112M4	174
5.1	3917	1.1	280	19500	—	—	—	—	W /VF 86/185_280	P112	BN112M4	162
5.1	3917	1.6	280	34500	—	—	—	—	VF/VF 130/210_280	P112	BN112M4	170
5.1	3992	2.3	280	52000	—	—	—	—	VF/VF 130/250_280	P112	BN112M4	176
5.3	3908	1.3	180	34500	—	—	—	—	VFR 210_180	P132	BN132MA6	168
5.3	4487	1.5	180	52000	—	—	—	—	VFR 250_180	P132	BN132MA6	174
5.9	3809	1.0	240	34500	—	—	—	—	VFR 210_240	P112	BN112M4	168
5.9	3938	1.4	240	52000	—	—	—	—	VFR 250_240	P112	BN112M4	174
7.9	3147	1.0	180	19500	—	—	—	—	VFR 185_180	P112	BN112M4	160
7.9	3099	1.4	180	34500	—	—	—	—	VFR 210_180	P112	BN112M4	168
7.9	3244	1.9	180	52000	—	—	—	—	VFR 250_180	P112	BN112M4	174
9.5	2704	1.2	150	19500	—	—	—	—	VFR 185_150	P112	BN112M4	160
9.5	2704	1.7	150	34500	—	—	—	—	VFR 210_150	P112	BN112M4	168
9.5	2704	2.4	150	52000	—	—	—	—	VFR 250_150	P112	BN112M4	174
9.5	2453	1.2	100	33000	—	—	—	—	VF 210_100	P132	BN132MA6	166
9.5	2533	1.9	100	50000	—	—	—	—	VF 250_100	P132	BN132MA6	172
11.8	2195	0.9	120	16000	—	—	—	—	VFR 150_120	P112	BN112M4	152
11.8	2260	1.6	120	19500	—	—	—	—	VFR 185_120	P112	BN112M4	160
11.8	2260	2.2	120	34500	—	—	—	—	VFR 210_120	P112	BN112M4	168
11.8	2292	3.1	120	52000	—	—	—	—	VFR 250_120	P112	BN112M4	174
11.9	2123	1.1	80	19000	—	—	—	—	VF 185_80	P132	BN132MA6	158
11.9	2091	1.6	80	33000	—	—	—	—	VF 210_80	P132	BN132MA6	166
11.9	2155	2.4	80	50000	—	—	—	—	VF 250_80	P132	BN132MA6	172
14.2	1749	1.1	100	18000	—	—	—	—	VF 185_100	P112	BN112M4	158
15.8	1719	0.9	90	13800	—	—	—	—	VFR 130_90	P112	BN112M4	144
15.8	1743	1.1	90	16000	—	—	—	—	VFR 150_90	P112	BN112M4	152
15.8	1840	1.5	90	19500	—	—	—	—	VFR 185_90	P112	BN112M4	160
15.8	1840	2.2	90	34500	—	—	—	—	VFR 210_90	P112	BN112M4	168
15.8	1888	3.2	90	52000	—	—	—	—	VFR 250_90	P112	BN112M4	174
15.8	1713	1.5	60	19000	—	—	—	—	VF 185_60	P132	BN132MA6	158
15.8	1689	2.2	60	33000	—	—	—	—	VF 210_60	P132	BN132MA6	166
15.8	1737	3.2	60	50000	—	—	—	—	VF 250_60	P132	BN132MA6	172
17.8	1485	1.4	80	18000	—	—	—	—	VF 185_80	P112	BN112M4	158
20.6	1411	0.9	69	13800	—	—	—	—	VFR 130_69	P112	BN112M4	144
20.6	1429	1.3	69	16000	—	—	—	—	VFR 150_69	P112	BN112M4	152
20.7	1369	1.3	46	15500	—	—	—	—	VF 150_46	P132	BN132MA6	150
21.1	1448	3.4	45	34500	—	—	—	—	VFR 210_45	P132	BN132MA6	168
22.2	1240	1.1	64	14700	—	—	—	—	VF 150_64	P112	BN112M4	150
23.7	1259	1.1	60	13800	—	—	—	—	VFR 130_60	P112	BN112M4	144
23.7	1275	1.5	60	16000	—	—	—	—	VFR 150_60	P112	BN112M4	152
23.7	1194	1.9	60	18000	—	—	—	—	VF 185_60	P112	BN112M4	158



4 kW







n ₂ min-1	M ₂ Nm	S	i	Rn ₂ N						IEC 		
23.7	1307	2.5	60	19500	—	—	—	VFR 185_60	P112	BN112M4	160	
23.7	1291	3.6	60	34500	—	—	—	VFR 210_60	P112	BN112M4	168	
23.8	1174	1.0	40	13200	—	—	—	VF 130_40	P132	BN132MA6	142	
23.8	1206	3.6	40	33000	—	—	—	VF 210_40	P132	BN132MA6	166	
25.4	1100	0.9	56	12500	—	—	—	VF 130_56	P112	BN112M4	142	
25.4	1115	1.2	56	14700	—	—	—	VF 150_56	P112	BN112M4	150	
28.4	1022	2.4	50	18000	—	—	—	VF 185_50	P112	BN112M4	158	
31	940	1.1	46	12600	—	—	—	VF 130_46	P112	BN112M4	142	
31	953	1.6	46	14700	—	—	—	VF 150_46	P112	BN112M4	150	
32	993	1.7	45	16000	—	—	—	VFR 150_45	P112	BN112M4	152	
32	1017	2.8	45	19500	—	—	—	VFR 185_45	P112	BN112M4	160	
32	929	1.3	30	13200	—	—	—	VF 130_30	P132	BN132MA6	142	
32	977	2.5	30	19000	—	—	—	VF 185_30	P132	BN132MA6	158	
32	965	3.5	30	33000	—	—	—	VF 210_30	P132	BN132MA6	166	
36	818	1.3	40	12600	—	—	—	VF 130_40	P112	BN112M4	142	
36	829	1.9	40	14700	—	—	—	VF 150_40	P112	BN112M4	150	
36	769	0.9	80	12600	—	—	—	VF 130_80	P112	BN112M2	142	
41	749	1.4	23	13200	—	—	—	VF 130_23	P132	BN132MA6	142	
41	758	2.0	23	13200	—	—	—	VF 150_23	P132	BN132MA6	150	
45	641	1.1	64	12600	—	—	—	VF 130_64	P112	BN112M2	142	
46	635	1.1	30	8000	W 110_30	S3	M3LC4	138	W 110_30	P112	BN112M4	139
47	638	1.6	30	12600	—	—	—	VF 130_30	P112	BN112M4	142	
47	646	2.1	30	14700	—	—	—	VF 150_30	P112	BN112M4	150	
47	686	2.2	30	16000	—	—	—	VFR 150_30	P112	BN112M4	152	
60	525	1.0	23	8000	W 110_23	S3	M3LC4	138	W 110_23	P112	BN112M4	139
62	514	1.7	23	12600	—	—	—	VF 130_23	P112	BN112M4	142	
62	514	2.5	23	14700	—	—	—	VF 150_23	P112	BN112M4	150	
63	485	1.6	46	12600	—	—	—	VF 130_46	P112	BN112M2	142	
70	462	1.2	20	8000	W 110_20	S3	M3LC4	138	W 110_20	P112	BN112M4	139
71	452	2.0	20	12400	—	—	—	VF 130_20	P112	BN112M4	142	
93	350	0.9	15	5410	W 86_15	S3	M3LC4	134	W 86_15	P112	BN112M4	135
93	346	1.7	15	8000	W 110_15	S3	M3LC4	138	W 110_15	P112	BN112M4	139
95	347	2.7	15	11400	—	—	—	VF 130_15	P112	BN112M4	142	
95	350	3.4	10	12700	—	—	—	VF 150_10	P132	BN132MA6	150	
139	242	1.0	10	2160	W 75_10	S3	M3LC4	130	W 75_10	P112	BN112M4	131
139	242	1.2	10	4940	W 86_10	S3	M3LC4	134	W 86_10	P112	BN112M4	135
139	239	2.3	10	7840	W 110_10	S3	M3LC4	138	W 110_10	P112	BN112M4	139
142	237	3.3	10	10100	—	—	—	VF 130_10	P112	BN112M4	142	
191	176	1.3	15	2400	W 75_15	S3	M3LB2	130	W 75_15	P112	BN112M2	131
191	174	1.7	15	4820	W 86_15	S3	M3LB2	134	W 86_15	P112	BN112M2	135
191	174	3.1	15	7380	W 110_15	S3	M3LB2	138	W 110_15	P112	BN112M2	139
199	173	1.1	7	1900	W 75_7	S3	M3LC4	130	W 75_7	P112	BN112M4	131
199	171	1.5	7	4490	W 86_7	S3	M3LC4	134	W 86_7	P112	BN112M4	135
199	171	2.9	7	7040	W 110_7	S3	M3LC4	138	W 110_7	P112	BN112M4	139
287	120	1.7	10	2210	W 75_10	S3	M3LB2	130	W 75_10	P112	BN112M2	131
287	120	2.2	10	4320	W 86_10	S3	M3LB2	134	W 86_10	P112	BN112M2	135
410	85	2.0	7	2010	W 75_7	S3	M3LB2	130	W 75_7	P112	BN112M2	131
410	85	2.7	7	3890	W 86_7	S3	M3LB2	134	W 86_7	P112	BN112M2	135

5.5 kW

n ₂ min-1	M ₂ Nm	S	i	Rn ₂ N						IEC 	
2.4	9630	0.9	600	52000	—	—	—	VF/VF 130/250_600	P132	BN132S4	176
3.4	7937	1.2	280	52000	—	—	—	VF/VF 130/250_280	P132	BN132MB6	176
3.6	7295	0.9	400	34500	—	—	—	VF/VF 130/210_400	P132	BN132S4	170
3.6	7149	1.3	400	52000	—	—	—	VF/VF 130/250_400	P132	BN132S4	176
5.1	5311	1.2	280	34500	—	—	—	VF/VF 130/210_280	P132	BN132S4	170
5.1	5413	1.7	280	52000	—	—	—	VF/VF 130/250_280	P132	BN132S4	176
5.3	6203	1.1	180	52000	—	—	—	VFR 250_180	P132	BN132MB6	174
6.3	5169	1.0	150	34500	—	—	—	VFR 210_150	P132	BN132MB6	168
6.3	5253	1.3	150	52000	—	—	—	VFR 250_150	P132	BN132MB6	174









5.5 kW







n ₂ min-1	M ₂ Nm	S	i	Rn ₂ N						IEC 	
8.0	4202	1.0	180	34500	—	—	—	VFR 210_180	P132	BN132S4	168
8.0	4399	1.4	180	52000	—	—	—	VFR 250_180	P132	BN132S4	174
9.5	3391	0.9	100	33000	—	—	—	VF 210_100	P132	BN132MB6	166
9.5	3502	1.4	100	50000	—	—	—	VF 250_100	P132	BN132MB6	172
9.6	3666	1.2	150	34500	—	—	—	VFR 210_150	P132	BN132S4	168
9.6	3666	1.8	150	52000	—	—	—	VFR 250_150	P132	BN132S4	174
11.8	2890	1.1	80	33000	—	—	—	VF 210_80	P132	BN132MB6	166
11.8	2979	1.7	80	50000	—	—	—	VF 250_80	P132	BN132MB6	172
12.0	3064	1.6	120	34500	—	—	—	VFR 210_120	P132	BN132S4	168
12.0	3108	2.3	120	52000	—	—	—	VFR 250_120	P132	BN132S4	174
14.4	2371	1.1	100	31500	—	—	—	VF 210_100	P132	BN132S4	166
14.4	2590	1.4	100	19500	—	—	—	VFR 185_100	P132	BN132S4	160
14.4	2480	1.5	100	47000	—	—	—	VF 250_100	P132	BN132S4	172
15.8	2368	1.1	60	19000	—	—	—	VF 185_60	P132	BN132MB6	158
15.8	2334	1.6	60	33000	—	—	—	VF 210_60	P132	BN132MB6	166
15.8	2401	2.3	60	50000	—	—	—	VF 250_60	P132	BN132MB6	172
16.0	2495	1.6	90	34500	—	—	—	VFR 210_90	P132	BN132S4	168
16.0	2561	2.3	90	52000	—	—	—	VFR 250_90	P132	BN132S4	174
18.0	2013	1.1	80	18000	—	—	—	VF 185_80	P132	BN132S4	158
18.0	2013	1.4	80	31500	—	—	—	VF 210_80	P132	BN132S4	166
18.0	2072	1.9	80	47000	—	—	—	VF 250_80	P132	BN132S4	172
19.2	2106	1.3	75	19500	—	—	—	VFR 185_75	P132	BN132S4	160
20.5	1892	0.9	46	15500	—	—	—	VF 150_46	P132	BN132MB6	150
21.0	2001	2.4	45	34500	—	—	—	VFR 210_45	P132	BN132MB6	168
21.0	2051	3.3	45	52000	—	—	—	VFR 250_45	P132	BN132MB6	174
23.6	1645	1.1	40	15500	—	—	—	VF 150_40	P132	BN132MB6	150
24.0	1620	1.4	60	18000	—	—	—	VF 185_60	P132	BN132S4	158
24.0	1598	1.9	60	31500	—	—	—	VF 210_60	P132	BN132S4	166
24.0	1751	2.7	60	34500	—	—	—	VFR 210_60	P132	BN132S4	168
24.0	1663	2.7	60	47000	—	—	—	VF 250_60	P132	BN132S4	172
24.0	1773	4.0	60	52000	—	—	—	VFR 250_60	P132	BN132S4	174
28.8	1430	1.3	50	15940	—	—	—	VFR 150_50	P132	BN132S4	152
28.8	1386	1.8	50	18000	—	—	—	VF 185_50	P132	BN132S4	158
28.8	1477	2.2	50	19500	—	—	—	VFR 185_50	P132	BN132S4	160
28.8	1386	2.4	50	31500	—	—	—	VF 210_50	P132	BN132S4	166
28.8	1386	3.2	50	47000	—	—	—	VF 250_50	P132	BN132S4	172
31	1292	1.2	46	14700	—	—	—	VF 150_46	P132	BN132S4	150
32	1284	1.0	30	13200	—	—	—	VF 130_30	P132	BN132MB6	142
32	1362	3.0	45	34500	—	—	—	VFR 210_45	P132	BN132S4	168
36	1109	1.0	40	12600	—	—	—	VF 130_40	P132	BN132S4	142
36	1123	1.4	40	14700	—	—	—	VF 150_40	P132	BN132S4	150
36	1138	2.3	40	18000	—	—	—	VF 185_40	P132	BN132S4	158
36	1138	3.1	40	31500	—	—	—	VF 210_40	P132	BN132S4	166
38	1101	1.5	37.5	15400	—	—	—	VFR 150_37.5	P132	BN132S4	152
38	1149	2.4	37.5	19500	—	—	—	VFR 185_37.5	P132	BN132S4	160
41	1035	1.0	23	13000	—	—	—	VF 130_23	P132	BN132MB6	142
41	1048	1.4	23	15300	—	—	—	VF 150_23	P132	BN132MB6	150
48	864	1.2	30	12600	—	—	—	VF 130_30	P132	BN132S4	142
48	875	1.6	30	14700	—	—	—	VF 150_30	P132	BN132S4	150
48	908	2.2	30	18000	—	—	—	VF 185_30	P132	BN132S4	158
48	908	3.4	30	31500	—	—	—	VF 210_30	P132	BN132S4	166
58	775	1.9	25	13400	—	—	—	VFR 150_25	P132	BN132S4	152
58	784	3.3	25	19500	—	—	—	VFR 185_25	P132	BN132S4	160
63	696	1.3	23	12100	—	—	—	VF 130_23	P132	BN132S4	142
63	696	1.8	23	14000	—	—	—	VF 150_23	P132	BN132S4	150
63	692	0.9	15	8000	—	—	—	W 110_15	P132	BN132MB6	138
72	613	0.9	20	8000	—	—	—	W 110_20	P132	BN132S4	138
72	613	1.5	20	11700	—	—	—	VF 130_20	P132	BN132S4	142
72	613	2.1	20	13500	—	—	—	VF 150_20	P132	BN132S4	150
96	460	1.3	15	8000	—	—	—	W 110_15	P132	BN132S4	138
96	471	2.0	15	12800	—	—	—	VF 130_15	P132	BN132S4	142
96	476	2.4	15	12400	—	—	—	VF 150_15	P132	BN132S4	150
126	359	1.9	23	10400	—	—	—	VF 130_23	P132	BN132SA2	142
126	359	2.7	23	11800	—	—	—	VF 150_23	P132	BN132SA2	150
144	317	1.7	10	7330	—	—	—	W 110_10	P132	BN132S4	138



5.5 kW







n ₂ min ⁻¹	M ₂ Nm	S	i	Rn ₂ N						IEC 	
144	321	2.5	10	9680	—	—	—	VF 130_10	P132	BN132SA4	142
144	321	3.3	10	11000	—	—	—	VF 150_10	P132	BN132SA4	150
193	237	2.3	15	7060	—	—	—	W 110_15	P132	BN132SA2	138
206	227	2.2	7	6600	—	—	—	W 110_7	P132	BN132SA4	138
206	227	3.3	7	8650	—	—	—	VF 130_7	P132	BN132SA4	142
289	162	3.0	10	6290	—	—	—	W 110_10	P132	BN132SA2	138
289	164	3.6	10	8110	—	—	—	VF 130_10	P132	BN132SA2	142
413	115	3.9	7	5640	—	—	—	W 110_7	P132	BN132SA2	138
413	116	4.8	7	7230	—	—	—	VF 130_7	P132	BN132SA2	142

7.5 kW







n ₂ min ⁻¹	M ₂ Nm	S	i	Rn ₂ N						IEC 	
3.6	9749	0.9	400	52000	—	—	—	VF/VF 130/250_400	P132	BN132MA4	176
5.1	7242	0.9	280	34500	—	—	—	VF/VF 130/210_280	P132	BN132MA4	170
5.1	7381	1.2	280	52000	—	—	—	VF/VF 130/250_280	P132	BN132MA4	176
6.4	7088	1.0	150	52000	—	—	—	VFR 250_150	P160	BN160M6	174
8.0	5940	1.0	120	34500	—	—	—	VFR 210_120	P160	BN160M6	168
8.0	5999	1.1	180	52000	—	—	—	VFR 250_180	P132	BN132MA4	174
9.6	4725	1.0	100	50000	—	—	—	VF 250_100	P160	BN160M6	172
9.6	4999	1.3	150	52000	—	—	—	VFR 250_150	P132	BN132MA4	174
10.6	4860	0.9	90	34500	—	—	—	VFR 210_90	P160	BN160M6	168
11.9	4020	1.3	80	50000	—	—	—	VF 250_80	P160	BN160M6	172
12.0	4178	1.2	120	34500	—	—	—	VFR 210_120	P132	BN132MA4	168
12.0	4238	1.7	120	52000	—	—	—	VFR 250_120	P132	BN132MA4	174
14.4	3532	1.0	100	19500	—	—	—	VFR 185_100	P132	BN132MA4	160
14.4	3382	1.1	100	47000	—	—	—	VF 250_100	P132	BN132MA4	172
15.9	3150	1.2	60	33000	—	—	—	VF 210_60	P160	BN160M6	166
16.0	3402	1.2	90	34500	—	—	—	VFR 210_90	P132	BN132MA4	168
16.0	3492	1.7	90	52000	—	—	—	VFR 250_90	P132	BN132MA4	174
18.0	2746	1.1	80	31500	—	—	—	VF 210_80	P132	BN132MA4	166
18.0	2825	1.4	80	47000	—	—	—	VF 250_80	P132	BN132MA4	172
19.2	2872	1.0	75	19500	—	—	—	VFR 185_75	P132	BN132MA4	160
21.2	2700	1.8	45	34500	—	—	—	VFR 210_45	P160	BN160M6	168
21.2	2768	2.5	45	52000	—	—	—	VFR 250_45	P160	BN160M6	174
24.0	2208	1.0	60	18000	—	—	—	VF 185_60	P132	BN132MA4	158
24.0	2179	1.4	60	31500	—	—	—	VF 210_60	P132	BN132MA4	166
24.0	2388	2.0	60	31500	—	—	—	VFR 210_60	P132	BN132MA4	168
24.0	2268	2.0	60	47000	—	—	—	VF 250_60	P132	BN132MA4	172
24.0	2417	2.9	60	52000	—	—	—	VFR 250_60	P132	BN132MA4	174
28.8	1950	1.0	50	14100	—	—	—	VFR 150_50	P132	BN132MA4	152
28.8	1890	1.3	50	18000	—	—	—	VF 185_50	P132	BN132MA4	158
28.8	2014	1.6	50	19500	—	—	—	VFR 185_50	P132	BN132MA4	160
28.8	1890	1.7	50	31500	—	—	—	VF 210_50	P132	BN132MA4	166
28.8	1890	2.4	50	47000	—	—	—	VF 250_50	P132	BN132MA4	172
31	1762	0.9	46	14700	—	—	—	VF 150_46	P132	BN132MA4	150
32	1858	2.2	45	34500	—	—	—	VFR 210_45	P132	BN132MA4	168
32	1880	3.4	45	48800	—	—	—	VFR 250_45	P132	BN132MA4	174
36	1532	1.0	40	14700	—	—	—	VF 150_40	P132	BN132MA4	150
36	1552	1.7	40	18000	—	—	—	VF 185_40	P132	BN132MA4	158
36	1552	2.3	40	31500	—	—	—	VF 210_40	P132	BN132MA4	166
36	1572	3.1	40	47000	—	—	—	VF 250_40	P132	BN132MA4	172
38	1501	1.1	37.5	13200	—	—	—	VFR 150_37.5	P132	BN132MA4	152
38	1567	1.8	37.5	18300	—	—	—	VFR 185_37.5	P132	BN132MA4	160
48	1179	0.9	30	11900	—	—	—	VF 130_30	P132	BN132MA4	142
48	1194	1.1	30	14200	—	—	—	VF 150_30	P132	BN132MA4	150
48	1239	1.6	30	18000	—	—	—	VF 185_30	P132	BN132MA4	158
48	1239	2.5	30	31500	—	—	—	VF 210_30	P132	BN132MA4	166
48	1283	3.0	30	33400	—	—	—	VFR 210_30	P132	BN132MA4	168
48	1253	3.2	30	4440	—	—	—	VF 250_30	P132	BN132MA4	172
58	1057	1.4	25	11000	—	—	—	VFR 150_25	P132	BN132MA4	152



7.5 kW







n ₂ min-1	M ₂ Nm	S	i	Rn ₂ N						IEC 	
58	1069	2.4	25	16700	—	—	—	VFR 185_25	P132	BN132MA4	160
63	950	0.9	23	11200	—	—	—	VF 130_23	P132	BN132MA4	142
63	950	1.3	23	13200	—	—	—	VF 150_23	P132	BN132MA4	150
64	968	2.3	15	16700	—	—	—	VF 185_15	P160	BN160M6	158
64	968	3.4	15	31500	—	—	—	VF 210_15	P160	BN160M6	166
72	836	1.1	20	10800	—	—	—	VF 130_20	P132	BN132MA4	142
72	836	1.6	20	12700	—	—	—	VF 150_20	P132	BN132MA4	150
96	627	1.0	15	7370	—	—	—	W 110_15	P132	BN132MA4	138
96	642	1.4	15	10200	—	—	—	VF 130_15	P132	BN132MA4	142
96	649	1.8	15	11700	—	—	—	VF 150_15	P132	BN132MA4	150
126	489	1.4	23	9900	—	—	—	VF 130_23	P132	BN132SB2	142
126	489	2.0	23	11400	—	—	—	VF 150_23	P132	BN132SB2	150
136	467	2.5	7	10200	—	—	—	VF 150_7	P160	BN160M6	150
144	433	1.3	10	6720	—	—	—	W 110_10	P132	BN132MA4	138
144	438	1.8	10	9150	—	—	—	VF 130_10	P132	BN132MA4	142
144	438	2.4	10	10500	—	—	—	VF 150_10	P132	BN132MA4	150
193	322	1.7	15	6660	—	—	—	W 110_15	P132	BN132SB2	138
206	310	1.6	7	6100	—	—	—	W 110_7	P132	BN132MA4	138
206	310	2.4	7	8210	—	—	—	VF 130_7	P132	BN132MA4	142
206	313	3.2	7	9400	—	—	—	VF 150_7	P132	BN132MA4	150
290	220	2.2	10	5980	—	—	—	W 110_10	P132	BN132SB2	138
290	222	2.7	10	7840	—	—	—	VF 130_10	P132	BN132SB2	142
414	156	2.9	7	5380	—	—	—	W 110_7	P132	BN132SB2	138
414	157	3.5	7	7010	—	—	—	VF 130_7	P132	BN132SB2	142

9.2 kW







n ₂ min-1	M ₂ Nm	S	i	Rn ₂ N						IEC 	
5.1	9054	1.0	280	52000	—	—	—	VF/VF 130/250_280	P132	BN132MB4	176
9.6	6132	1.1	150	52000	—	—	—	VFR 250_150	P132	BN132MB4	174
12.0	5198	1.3	120	52000	—	—	—	VFR 250_120	P132	BN132MB4	174
14.4	4149	0.9	100	47000	—	—	—	VF 250_100	P132	BN132MB4	172
16.0	4173	1.0	90	34500	—	—	—	VFR 210_90	P132	BN132MB4	168
16.0	4283	1.4	90	52000	—	—	—	VFR 250_90	P132	BN132MB4	174
18.0	3368	0.9	80	31500	—	—	—	VF 210_80	P132	BN132MB4	166
18.0	3466	1.1	80	47000	—	—	—	VF 250_80	P132	BN132MB4	172
24.0	2672	1.1	60	31500	—	—	—	VF 210_60	P132	BN132MB4	166
24.0	2929	1.6	60	34500	—	—	—	VFR 210_60	P132	BN132MB4	168
24.0	2782	1.6	60	47000	—	—	—	VF 250_60	P132	BN132MB4	172
24.0	2965	2.4	60	51900	—	—	—	VFR 250_60	P132	BN132MB4	174
28.8	2319	1.1	50	18000	—	—	—	VF 185_50	P132	BN132MB4	158
28.8	2471	1.3	50	18600	—	—	—	VFR 185_50	P132	BN132MB4	160
28.8	2319	1.4	50	31500	—	—	—	VF 210_50	P132	BN132MB4	166
28.8	2319	1.9	50	47000	—	—	—	VF 250_50	P132	BN132MB4	172
32	2279	1.8	45	34500	—	—	—	VFR 210_45	P132	BN132MB4	168
32	2306	2.8	45	48000	—	—	—	VFR 250_45	P132	BN132MB4	174
36	1904	1.4	40	18000	—	—	—	VF 185_40	P132	BN132MB4	158
36	1904	1.8	40	31500	—	—	—	VF 210_40	P132	BN132MB4	166
36	1928	2.5	40	47000	—	—	—	VF 250_40	P132	BN132MB4	172
38	1884	0.9	37.5	11900	—	—	—	VFR 150_37.5	P132	BN132MB4	152
38	1922	1.5	37.5	17200	—	—	—	VFR 185_37.5	P132	BN132MB4	160
48	1464	0.9	30	11300	—	—	—	VF 150_30	P132	BN132MB4	150
48	1519	1.3	30	17900	—	—	—	VF 185_30	P132	BN132MB4	158
48	1519	2.0	30	31500	—	—	—	VF 210_30	P132	BN132MB4	166
48	1574	2.4	30	32600	—	—	—	VFR 210_30	P132	BN132MB4	168
48	1538	2.6	30	43900	—	—	—	VF 250_30	P132	BN132MB4	172
48	1574	3.8	30	42800	—	—	—	VFR 250_30	P132	BN132MB4	174
58	1297	1.2	25	11200	—	—	—	VFR 150_25	P132	BN132MB4	152
58	1312	2.0	25	15800	—	—	—	VFR 185_25	P132	BN132MB4	160
63	1165	1.1	23	12500	—	—	—	VF 150_23	P132	BN132MB4	150
72	1025	0.9	20	10100	—	—	—	VF 130_20	P132	BN132MB4	142



9.2 kW







n ₂ min ⁻¹	M ₂ Nm	S	i	R _{n2} N						IEC 	
72	1025	1.3	20	12100	—	—	—	VF 150_20	P132	BN132MB4	150
72	1037	3.0	20	30400	—	—	—	VF 210_20	P132	BN132MB4	166
96	787	1.2	15	9560	—	—	—	VF 130_15	P132	BN132MB4	142
96	796	1.4	15	11200	—	—	—	VF 150_15	P132	BN132MB4	150
126	599	1.1	23	9510	—	—	—	VF 130_23	P132	BN132M2	142
126	599	1.6	23	11000	—	—	—	VF 150_23	P132	BN132M2	150
144	531	1.0	10	6210	—	—	—	W 110_10	P132	BN132MB4	138
144	537	1.5	10	8690	—	—	—	VF 130_10	P132	BN132MB4	142
144	537	2.0	10	16100	—	—	—	VF 150_10	P132	BN132MB4	150
193	395	1.4	15	6320	—	—	—	W 110_15	P132	BN132M2	138
206	380	1.3	7	5670	—	—	—	W 110_7	P132	BN132MB4	138
206	380	1.9	7	7820	—	—	—	VF 130_7	P132	BN132MB4	142
206	384	2.6	7	9030	—	—	—	VF 150_7	P132	BN132MB4	150
290	270	1.8	10	5720	—	—	—	W 110_10	P132	BN132M2	138
290	273	2.2	10	7620	—	—	—	VF 130_10	P132	BN132M2	142
290	273	2.9	10	8690	—	—	—	VF 150_10	P132	BN132M2	150
414	191	2.3	7	5170	—	—	—	W 110_7	P132	BN132M2	138
414	193	2.9	7	6820	—	—	—	VF 130_7	P132	BN132M2	142

11 kW







n ₂ min ⁻¹	M ₂ Nm	S	i	R _{n2} N						IEC 	
8.0	8798	0.9	120	52000	—	—	—	VFR 250_120	P160	BN160L6	174
10.7	7288	0.9	90	52000	—	—	—	VFR 250_90	P160	BN160L6	174
12.0	5865	0.9	80	50000	—	—	—	VF 250_80	P160	BN160L6	172
12.0	6215	1.1	120	52000	—	—	—	VFR 250_120	P160	BN160MR4	174
16.0	5056	1.1	60	34500	—	—	—	VFR 210_60	P160	BN160L6	168
16.0	5121	1.2	90	52000	—	—	—	VFR 250_90	P160	BN160MR4	174
16.0	4727	1.2	60	50000	—	—	—	VF 250_60	P160	BN160L6	172
18.0	4144	0.9	80	47000	—	—	—	VF 250_80	P160	BN160MR4	172
19.2	3939	1.0	50	33000	—	—	—	VF 210_50	P160	BN160L6	166
21.3	3939	1.2	45	34500	—	—	—	VFR 210_45	P160	BN160L6	168
21.3	4038	1.7	45	51300	—	—	—	VFR 250_45	P160	BN160L6	174
24.0	3327	0.9	40	18000	—	—	—	VF 185_40	P160	BN160L6	158
24.0	3195	0.9	60	31500	—	—	—	VF 210_60	P160	BN160MR4	166
24.0	3283	1.3	40	33000	—	—	—	VF 210_40	P160	BN160L6	166
24.0	3502	1.3	60	34500	—	—	—	VFR 210_60	P160	BN160MR4	168
24.0	3327	1.4	60	47000	—	—	—	VF 250_60	P160	BN160MR4	172
24.0	3327	2.0	40	50000	—	—	—	VF 250_40	P160	BN160L6	172
24.0	3545	2.0	60	50900	—	—	—	VFR 250_60	P160	BN160MR4	174
28.8	2772	1.2	50	31500	—	—	—	VF 210_50	P160	BN160MR4	166
28.8	2772	1.6	50	47000	—	—	—	VF 250_50	P160	BN160MR4	172
32	2659	0.9	30	18100	—	—	—	VF 185_30	P160	BN160L6	158
32	2725	1.5	45	34500	—	—	—	VFR 210_45	P160	BN160MR4	168
32	2758	2.3	45	47100	—	—	—	VFR 250_45	P160	BN160MR4	174
36	2276	1.2	40	18500	—	—	—	VF 185_40	P160	BN160MR4	158
36	2276	1.5	40	31500	—	—	—	VF 210_40	P160	BN160MR4	166
36	2305	2.1	40	47000	—	—	—	VF 250_40	P160	BN160MR4	172
48	1816	1.1	30	17200	—	—	—	VF 185_30	P160	BN160MR4	158
48	1816	1.7	30	31500	—	—	—	VF 210_30	P160	BN160MR4	166
48	1882	2.0	30	31800	—	—	—	VFR 210_30	P160	BN160MR4	168
48	1838	2.2	30	43400	—	—	—	VF 250_30	P160	BN160MR4	172
48	1882	3.2	30	42100	—	—	—	VFR 250_30	P160	BN160MR4	174
48	1860	3.2	20	43100	—	—	—	VF 250_20	P160	BN160L6	172
64	1395	1.0	15	10900	—	—	—	VF 150_15	P160	BN160L6	150
64	1412	1.6	15	15300	—	—	—	VF 185_15	P160	BN160L6	158
64	1412	2.3	15	30500	—	—	—	VF 210_15	P160	BN160L6	166
72	1226	1.1	20	11400	—	—	—	VF 150_20	P160	BN160MR4	150
72	1240	1.8	20	15600	—	—	—	VF 185_20	P160	BN160MR4	158
72	1240	2.5	20	30000	—	—	—	VF 210_20	P160	BN160MR4	166
96	952	1.2	15	10600	—	—	—	VF 150_15	P160	BN160MR4	150









11 kW

n ₂ min ⁻¹	M ₂ Nm	S	i	R _{n2} N						IEC 	
96	963	1.9	15	14200	—	—	—	VF 185_15	P160	BN160MR4	158
96	963	3.0	15	27700	—	—	—	VF 210_15	P160	BN160MR4	166
144	642	1.6	10	9670	—	—	—	VF 150_10	P160	BN160MR4	150
146	635	2.7	20	13300	—	—	—	VF 185_20	P160	BN160MR2	158
194	482	2.9	15	12200	—	—	—	VF 185_15	P160	BN160MR2	158
206	460	2.2	7	8660	—	—	—	VF 150_7	P160	BN160MR4	150
291	325	2.4	10	8440	—	—	—	VF 150_10	P160	BN160MR2	150
416	230	3.3	7	7530	—	—	—	VF 150_7	P160	BN160MR2	150

15 kW







n ₂ min ⁻¹	M ₂ Nm	S	i	R _{n2} N						IEC 	
16.2	6380	0.9	60	50000	—	—	—	VF 250_60	P180	BN180L6	172
19.4	5390	1.2	50	50000	—	—	—	VF 250_50	P180	BN180L6	172
24.3	4430	1.0	40	33000	—	—	—	VF 210_40	P180	BN180L6	166
24.3	4489	1.4	40	50000	—	—	—	VF 250_40	P180	BN180L6	172
24.3	4474	1.0	60	47000	—	—	—	VF 250_60	P160	BN160L4	172
24.3	4768	1.5	60	48700	—	—	—	VFR 250_60	P160	BN160L4	174
29.2	3728	0.9	50	31500	—	—	—	VF 210_50	P160	BN160L4	166
29.2	3728	1.2	50	47000	—	—	—	VF 250_50	P160	BN160L4	172
32	3665	1.1	45	33200	—	—	—	VFR 210_45	P160	BN160L4	168
32	3709	1.7	45	45200	—	—	—	VFR 250_45	P160	BN160L4	174
37	3061	0.9	40	16600	—	—	—	VF 185_40	P160	BN160L4	158
37	3061	1.1	40	31500	—	—	—	VF 210_40	P160	BN160L4	166
37	3100	1.5	40	45900	—	—	—	VF 250_40	P160	BN160L4	172
49	2481	1.1	20	14800	—	—	—	VF 185_20	P180	BN180L6	158
49	2443	1.2	30	31500	—	—	—	VF 210_30	P160	BN160L4	166
49	2531	1.5	30	30000	—	—	—	VFR 210_30	P160	BN160L4	168
49	2473	1.6	30	42400	—	—	—	VF 250_30	P160	BN160L4	172
49	2531	2.4	30	40600	—	—	—	VFR 250_30	P160	BN160L4	174
65	1905	1.2	15	13600	—	—	—	VF 185_15	P180	BN180L6	158
65	1905	1.7	15	29300	—	—	—	VF 210_15	P180	BN180L6	166
65	1927	2.8	15	38700	—	—	—	VF 250_15	P180	BN180L6	172
73	1668	1.4	20	14300	—	—	—	VF 185_20	P160	BN160L4	158
73	1668	1.9	20	29100	—	—	—	VF 210_20	P160	BN160L4	166
73	1688	2.6	20	38100	—	—	—	VF 250_20	P160	BN160L4	172
97	1280	0.9	15	9360	—	—	—	VF 150_15	P160	BN160L4	150
97	1295	1.4	15	13200	—	—	—	VF 185_15	P160	BN160L4	158
97	1295	2.2	15	27000	—	—	—	VF 210_15	P160	BN160L4	166
97	1295	3.1	15	35100	—	—	—	VF 250_15	P160	BN160L4	172
139	920	2.2	7	11400	—	—	—	VF 185_7	P180	BN180L6	158
146	863	1.2	10	8720	—	—	—	VF 150_10	P160	BN160L4	150
146	873	3.0	10	24000	—	—	—	VF 210_10	P160	BN160L4	166
147	860	2.0	20	12700	—	—	—	VF 185_20	P160	BN160MB2	158
195	653	2.1	15	11600	—	—	—	VF 185_15	P160	BN160MB2	158
195	653	3.3	15	22700	—	—	—	VF 210_15	P160	BN160MB2	166
209	618	1.6	7	7840	—	—	—	VF 150_7	P160	BN160L4	150
293	440	1.8	10	7960	—	—	—	VF 150_10	P160	BN160MB2	150
419	311	2.4	7	7120	—	—	—	VF 150_7	P160	BN160MB2	150

18.5 kW







n ₂ min ⁻¹	M ₂ Nm	S	i	R _{n2} N						IEC 	
19.2	6717	0.9	50	50000	—	—	—	VF 250_50	P200	BN200LA6	172
24.0	5595	1.2	40	48700	—	—	—	VF 250_40	P200	BN200LA6	172
29.2	4598	1.0	50	47000	—	—	—	VF 250_50	P180	BN180M4	172
32	4472	1.2	30	45200	—	—	—	VF 250_30	P200	BN200LA6	172









18.5 kW

n ₂ min ⁻¹	M ₂ Nm	S	i	R _{n2} N						IEC 	
37	3776	0.9	40	31500	—	—	—	VF 210_40	P180	BN180M4	166
37	3824	1.3	40	44900	—	—	—	VF 250_40	P180	BN180M4	172
49	3013	1.0	30	31200	—	—	—	VF 210_30	P180	BN180M4	166
49	3049	1.3	30	41500	—	—	—	VF 250_30	P180	BN180M4	172
64	2374	1.4	15	28300	—	—	—	VF 210_15	P200	BN200LA6	166
64	2402	2.2	15	37800	—	—	—	VF 250_15	P200	BN200LA6	172
73	2057	1.1	20	13200	—	—	—	VF 185_20	P180	BN180M4	158
73	2057	1.5	20	28300	—	—	—	VF 210_20	P180	BN180M4	166
73	2081	2.1	20	37400	—	—	—	VF 250_20	P180	BN180M4	172
97	1597	1.2	15	12200	—	—	—	VF 185_15	P180	BN180M4	158
97	1597	1.8	15	26200	—	—	—	VF 210_15	P180	BN180M4	166
97	1597	2.5	15	34500	—	—	—	VF 250_15	P180	BN180M4	172
146	1077	1.7	10	11400	—	—	—	VF 185_10	P180	BN180M4	158
146	1077	2.5	10	23400	—	—	—	VF 210_10	P180	BN180M4	166
146	1089	3.4	10	37800	—	—	—	VF 250_10	P180	BN180M4	172
195	805	1.1	15	8260	—	—	—	VF 150_15	P160	BN160L2	150
209	762	2.3	7	10100	—	—	—	VF 185_7	P180	BN180M4	158
209	762	3.0	7	21200	—	—	—	VF 210_7	P180	BN180M4	166
293	543	1.5	10	7550	—	—	—	VF 150_10	P160	BN160L2	150
419	384	2.0	7	6760	—	—	—	VF 150_7	P160	BN160L2	150

22 kW







n ₂ min ⁻¹	M ₂ Nm	S	i	R _{n2} N						IEC 	
22.5	7097	0.9	40	47100	—	—	—	VF 250_40	P200	BN200L6	172
30	5673	1.0	30	43900	—	—	—	VF 250_30	P200	BN200L6	172
37	4532	1.1	40	43900	—	—	—	VF 250_40	P180	BN180L4	172
49	3571	0.9	30	30200	—	—	—	VF 210_30	P180	BN180L4	166
49	3614	1.1	30	44700	—	—	—	VF 250_30	P180	BN180L4	172
60	3011	1.1	15	27200	—	—	—	VF 210_15	P200	BN200L6	166
60	3046	1.7	15	36900	—	—	—	VF 250_15	P200	BN200L6	172
73	2438	0.9	20	12200	—	—	—	VF 185_20	P180	BN180L4	158
73	2438	1.3	20	27500	—	—	—	VF 210_20	P180	BN180L4	166
73	2467	1.8	20	36700	—	—	—	VF 250_20	P180	BN180L4	172
98	1893	1.0	15	11300	—	—	—	VF 185_15	P180	BN180L4	158
98	1893	1.5	15	25500	—	—	—	VF 210_15	P180	BN180L4	166
98	1893	2.1	15	33900	—	—	—	VF 250_15	P180	BN180L4	172
147	1276	1.4	10	10700	—	—	—	VF 185_10	P180	BN180L4	158
147	1276	2.1	10	22900	—	—	—	VF 210_10	P180	BN180L4	166
147	1291	2.9	10	30300	—	—	—	VF 250_10	P180	BN180L4	172
209	904	1.9	7	9510	—	—	—	VF 185_7	P180	BN180L4	158
209	904	2.5	7	20800	—	—	—	VF 210_7	P180	BN180L4	166
209	914	3.5	7	27500	—	—	—	VF 250_7	P180	BN180L4	172
293	645	2.1	10	9730	—	—	—	VF 185_10	P180	BN180M2	158
293	645	3.1	10	23900	—	—	—	VF 210_10	P180	BN180M2	166
419	457	2.9	7	8660	—	—	—	VF 185_7	P180	BN180M2	158

30 kW







n ₂ min ⁻¹	M ₂ Nm	S	i	R _{n2} N						IEC 	
45	5412	1.1	20	37600	—	—	—	VF 250_20	P225	BN225M6	172
60	4154	1.3	15	35000	—	—	—	VF 250_15	P225	BN225M6	172
74	3313	0.9	20	25800	—	—	—	VF 210_20	P200	BN200L4	166
74	3352	1.3	20	35200	—	—	—	VF 250_20	P200	BN200L4	172
98	2573	1.1	15	24000	—	—	—	VF 210_15	P200	BN200L4	166
98	2573	1.6	15	32600	—	—	—	VF 250_15	P200	BN200L4	172
147	1735	1.5	10	21600	—	—	—	VF 210_10	P200	BN200L4	166









30 kW

n_2 min ⁻¹	M_2 Nm	S	i	R_{n2} N						IEC 	
147	1754	2.1	10	29200	—	—	—	VF 250_10	P200	BN200L4	172
210	1228	1.9	7	19700	—	—	—	VF 210_7	P200	BN200L4	166
210	1242	2.6	7	26600	—	—	—	VF 250_7	P200	BN200L4	172
295	874	2.3	10	19000	—	—	—	VF 210_10	P200	BN200LA2	166
421	619	2.8	7	17200	—	—	—	VF 210_7	P200	BN200LA2	166

37 kW

n_2 min ⁻¹	M_2 Nm	S	i	R_{n2} N						IEC 	
74	4107	1.1	20	22800	—	—	—	VF 250_20	P225	BN225S4	172
99	3152	0.9	15	22600	—	—	—	VF 210_15	P225	BN225S4	166
99	3152	1.3	15	31400	—	—	—	VF 250_15	P225	BN225S4	172
148	2125	1.2	10	20500	—	—	—	VF 210_10	P225	BN225S4	166
148	2149	1.7	10	28300	—	—	—	VF 250_10	P225	BN225S4	172
211	1504	1.5	7	18800	—	—	—	VF 210_7	P225	BN225S4	166
211	1521	2.1	7	25800	—	—	—	VF 250_7	P225	BN225S4	172
296	1074	1.9	10	18400	—	—	—	VF 210_10	P200	BN200L2	166
296	1086	2.6	10	24500	—	—	—	VF 250_10	P200	BN200L2	172
423	760	2.3	7	16800	—	—	—	VF 210_7	P200	BN200L2	166

45 kW



n_2 min ⁻¹	M_2 Nm	S	i	R_{n2} N						IEC 	
74	4994	0.9	20	32300	—	—	—	VF 250_20	P225	BN225M4	172
99	3833	1.0	15	30100	—	—	—	VF 250_15	P225	BN225M4	172
148	2584	1.0	10	19200	—	—	—	VF 210_10	P225	BN225M4	166
148	2613	1.4	10	27300	—	—	—	VF 250_10	P225	BN225M4	172
211	1829	1.3	7	17800	—	—	—	VF 210_7	P225	BN225M4	166
211	1850	1.7	7	25000	—	—	—	VF 250_7	P225	BN225M4	172
296	1307	1.5	10	17800	—	—	—	VF 210_10	P200	BN225M2	166
296	1321	2.1	10	24000	—	—	—	VF 250_10	P200	BN225M2	172
423	925	1.9	7	16200	—	—	—	VF 210_7	P200	BN225M2	166
423	935	2.6	7	21800	—	—	—	VF 250_7	P200	BN225M2	172



22 TABLAS DE DATOS TÉCNICOS DE REDUCTORES



VF 27

13 Nm

		i	η_s %	n_2	M_{n2}	P_{n1}	R_{n1}	R_{n2}	η_d	n_2	M_{n2}	P_{n1}	R_{n1}	R_{n2}	η_d	
				min ⁻¹	Nm	kW	N	N	%	min ⁻¹	Nm	kW	N	N	%	
				$n_1 = 2800 \text{ min}^{-1}$					$n_1 = 1400 \text{ min}^{-1}$							
VF 27	VF 27_7	7	67	400	7	0.34	—	330	86	200	9	0.23	35	410	83	177
	VF 27_10	10	62	280	7	0.24	—	400	84	140	9	0.16	30	500	80	
	VF 27_15	15	54	187	7	0.17	—	480	79	93	9	0.12	—	600	75	
	VF 27_20	20	49	140	7	0.14	—	540	76	70	9	0.09	—	600	71	
	VF 27_30	30	38	93	7	0.10	—	600	69	47	9	0.07	—	600	62	
	VF 27_40	40	33	70	7	0.08	—	600	64	35	9	0.06	—	600	57	
	VF 27_60	60	26	47	7	0.06	—	600	56	23.3	9	0.04	—	600	49	
	VF 27_70	70	24	40	7	0.06	—	600	53	20.0	9	0.04	—	600	45	
					$n_1 = 900 \text{ min}^{-1}$					$n_1 = 500 \text{ min}^{-1}$						
	VF 27_7	7	67	129	10	0.17	90	480	81	71	11	0.11	90	600	79	177
	VF 27_10	10	62	90	11	0.13	20	570	78	50	12	0.08	90	600	76	
	VF 27_15	15	54	60	11	0.09	—	600	72	33	12	0.06	90	600	69	
	VF 27_20	20	49	45	11	0.08	—	600	68	25.0	12	0.05	90	600	65	
	VF 27_30	30	38	30.0	11	0.06	—	600	59	16.7	13	0.04	—	600	55	
VF 27_40	40	33	22.5	11	0.05	—	600	54	12.5	13	0.04	—	600	50		
VF 27_60	60	26	15.0	11	0.04	—	600	45	8.3	12	0.02	—	600	41		
VF 27_70	70	24	12.9	10	0.03	—	600	42	7.1	11	0.02	—	600	38		

VF 30

24 Nm

		i	η_s %	n_2	M_{n2}	P_{n1}	R_{n1}	R_{n2}	η_d	n_2	M_{n2}	P_{n1}	R_{n1}	R_{n2}	η_d	
				min ⁻¹	Nm	kW	N	N	%	min ⁻¹	Nm	kW	N	N	%	
				$n_1 = 2800 \text{ min}^{-1}$					$n_1 = 1400 \text{ min}^{-1}$							
VF 30	VF 30_7	7	69	400	12	0.58	120	510	87	200	16	0.41	140	630	84	178
	VF 30_10	10	64	280	12	0.41	70	620	85	140	16	0.30	80	770	81	
	VF 30_15	15	56	187	14	0.34	—	720	81	93	18	0.24	—	910	76	
	VF 30_20	20	51	140	14	0.26	—	820	78	70	18	0.19	—	1030	73	
	VF 30_30	30	41	93	15	0.21	—	960	71	47	20	0.15	—	1200	65	
	VF 30_40	40	36	70	14	0.16	—	1090	66	35	19	0.12	—	1360	60	
	VF 30_60	60	29	47	14	0.12	—	1270	59	23.3	19	0.09	—	1590	51	
	VF 30_70	70	26	40	11	0.08	—	1380	55	20.0	15	0.07	—	1600	48	
					$n_1 = 900 \text{ min}^{-1}$					$n_1 = 500 \text{ min}^{-1}$						
	VF 30_7	7	69	129	18	0.30	150	730	82	71	20	0.19	150	920	81	178
	VF 30_10	10	64	90	18	0.22	150	900	79	50	20	0.14	150	1120	77	
	VF 30_15	15	56	60	20	0.17	—	1060	74	33	22	0.11	150	1320	71	
	VF 30_20	20	51	45	20	0.14	—	1200	70	25.0	22	0.09	150	1490	67	
	VF 30_30	30	41	30	22	0.12	—	1400	61	16.7	24	0.07	—	1700	58	
VF 30_40	40	36	23	20	0.09	—	1590	56	12.5	22	0.06	—	1700	53		
VF 30_60	60	29	15	20	0.07	—	1650	48	8.3	22	0.05	—	1700	44		
VF 30_70	70	26	13	17	0.05	—	1700	45	7.0	19	0.04	—	1700	41		

(-) Contactar a nuestro servicio técnico, comunicando los datos relativos a la carga radial (sentido de giro, orientación y posición)



VF 44 - VF/VF 30/44

55 Nm

		i	η _s %	n ₁ = 2800 min ⁻¹						n ₁ = 1400 min ⁻¹								
				n ₂ min ⁻¹	M _{n2} Nm	P _{n1} kW	R _{n1} N	R _{n2} N	η _d %	n ₂ min ⁻¹	M _{n2} Nm	P _{n1} kW	R _{n1} N	R _{n2} N	η _d %			
				VF 44	VF 44_7	7	71	400	22	1.1	220	950	88	200	29		0.71	220
VF 44_10	10	66	280		22	0.74	220	1150	87	140	29	0.51	220	1430	84			
VF 44_14	14	60	200		22	0.55	220	1340	84	100	29	0.37	220	1680	81			
VF 44_20	20	55	140		29	0.52	220	1490	81	70	39	0.37	220	1860	77			
VF 44_28	28	45	100		29	0.40	220	1710	76	50	39	0.29	220	2140	71			
VF 44_35	35	42	80		29	0.33	220	1870	73	40	39	0.25	220	2300	68			
VF 44_46	46	37	61		29	0.27	220	2080	69	30.0	39	0.19	220	2300	63			
VF 44_60	60	32	47		29	0.22	220	2290	65	23.3	39	0.16	220	2300	58			
VF 44_70	70	30	40		22	0.15	220	2300	62	20.0	29	0.11	220	2300	55			
VF 44_100	100	24	28		21	0.11	220	2300	55	14.0	28	0.09	220	2300	47			
					n ₁ = 900 min ⁻¹						n ₁ = 500 min ⁻¹							
VF 44_7	7	71	129		39	0.63	220	1300	85	71	45	0.41	220	1610	83	178		
VF 44_10	10	66	90		39	0.45	220	1610	82	50	45	0.29	220	1980	80			
VF 44_14	14	60	64		39	0.34	220	1890	78	36	50	0.25	220	2280	76			
VF 44_20	20	55	45		45	0.29	220	2160	74	25.0	50	0.18	220	2500	72			
VF 44_28	28	45	32		49	0.24	220	2300	67	17.9	55	0.16	220	2500	64			
VF 44_35	35	42	25.7		49	0.20	220	2300	64	14.3	55	0.14	220	2500	60			
VF 44_46	46	37	19.6		49	0.17	220	2300	59	10.9	50	0.10	220	2500	55			
VF 44_60	60	32	15.0	45	0.13	200	2300	54	8.3	50	0.09	220	2500	50				
VF 44_70	70	30	12.9	39	0.10	220	2300	51	7.1	45	0.07	220	2500	47				
VF 44_100	100	24	9.0	30	0.06	220	2300	43	5.0	32	0.04	220	2500	39				

70 Nm

		i	η _s %	n ₁ = 1400 min ⁻¹						n ₁ = 900 min ⁻¹						
				n ₂ min ⁻¹	M _{n2} Nm	P _{n1} kW	R _{n1} N	R _{n2} N	η _d %	n ₂ min ⁻¹	M _{n2} Nm	P _{n1} kW	R _{n1} N	R _{n2} N	η _d %	
				VF/VF 30/44	VF/VF 30/44_245	245	29	5.7	60	0.09	140	2500	40	3.7	70	
VF/VF 30/44_350	350	27	4.0		60	0.07	80	2500	36	2.6	70	0.05	150	2500	38	
VF/VF 30/44_420	420	25	3.3		60	0.06	—	2500	35	2.1	70	0.04	—	2500	39	
VF/VF 30/44_560	560	23	2.5		60	0.05	—	2500	31	1.6	70	0.04	—	2500	29	
VF/VF 30/44_700	700	21	2.0		60	0.04	—	2500	31	1.3	70	0.03	—	2500	31	
VF/VF 30/44_840	840	18	1.7		60	0.04	—	2500	26	1.1	70	0.03	—	2500	26	
VF/VF 30/44_1120	1120	16	1.3		60	0.03	—	2500	26	0.80	70	0.02	—	2500	29	
VF/VF 30/44_1680	1680	13	0.83		60	0.02	—	2500	26	0.54	70	0.02	—	2500	20	
VF/VF 30/44_2100	2100	12	0.67		60	0.02	—	2500	21	0.43	70	0.02	—	2500	16	

(-) Contactar a nuestro servicio técnico, comunicando los datos relativos a la carga radial (sentido de giro, orientación y posición)



VF 49 - VFR 49

88 Nm

		i	η _s %	n ₁ = 2800 min ⁻¹						n ₁ = 1400 min ⁻¹						
				n ₂ min ⁻¹	M _{n2} Nm	P _{n1} kW	R _{n1} N	R _{n2} N	η _d %	n ₂ min ⁻¹	M _{n2} Nm	P _{n1} kW	R _{n1} N	R _{n2} N	η _d %	
				VF 49												
	VF 49_7	7	70	400	41	2.0	400	950	88	200	54	1.3	400	1170	86	178
	VF 49_10	10	65	280	44	1.5	400	1140	86	140	59	1.0	400	1410	84	
	VF 49_14	14	59	200	49	1.2	400	1310	84	100	65	0.90	400	1630	81	
	VF 49_18	18	55	156	44	0.87	400	1520	82	78	59	0.60	400	1890	78	
	VF 49_24	24	50	117	47	0.73	400	1670	79	58	63	0.50	400	2110	75	
	VF 49_28	28	43	100	56	0.78	400	1740	75	50	74	0.55	400	2170	71	
	VF 49_36	36	39	78	52	0.59	400	1970	72	39	69	0.42	400	2460	67	
	VF 49_45	45	35	62	49	0.46	400	2180	69	31	65	0.33	400	2725	63	
	VF 49_60	60	30	47	44	0.34	400	2480	64	23.3	59	0.25	400	3100	58	
	VF 49_70	70	28	40	41	0.28	400	2650	61	20.0	55	0.21	400	3150	54	
	VF 49_80	80	25	35	41	0.25	400	2780	59	17.5	54	0.19	400	3150	52	
	VF 49_100	100	22	28.0	37	0.20	400	3050	54	14.0	49	0.13	400	3150	47	
				n ₁ = 900 min ⁻¹						n ₁ = 500 min ⁻¹						
	VF 49_7	7	70	129	61	0.97	400	1370	85	71	74	0.67	400	1670	83	178
	VF 49_10	10	65	90	64	0.75	400	1670	82	50	74	0.49	400	2060	80	
	VF 49_14	14	59	64	71	0.61	400	1920	78	36	78	0.39	400	2400	75	
	VF 49_18	18	55	50	68	0.47	400	2190	75	27.8	74	0.30	400	2730	72	
	VF 49_24	24	50	38	68	0.36	400	2480	71	20.8	74	0.24	400	3090	68	
	VF 49_28	28	43	32	82	0.41	400	2540	67	17.9	88	0.26	400	3180	63	
	VF 49_36	36	39	25.0	75	0.31	400	2880	63	13.9	80	0.20	400	3450	59	
	VF 49_45	45	35	20.0	71	0.25	400	3190	59	11.1	78	0.17	400	3450	55	
	VF 49_60	60	30	15.0	64	0.19	400	3300	53	8.3	69	0.12	400	3450	49	
	VF 49_70	70	28	12.9	60	0.16	400	3300	50	7.1	69	0.11	400	3450	46	
	VF 49_80	80	25	11.3	58	0.14	400	3300	47	6.3	59	0.09	400	3450	43	
	VF 49_100	100	22	9.0	52	0.11	400	3300	42	5.0	59	0.08	400	3450	38	

95 Nm

		i	η _s %	n ₁ = 2800 min ⁻¹						n ₁ = 1400 min ⁻¹						
				n ₂ min ⁻¹	M _{n2} Nm	P _{n1} kW	R _{n1} N	R _{n2} N	η _d %	n ₂ min ⁻¹	M _{n2} Nm	P _{n1} kW	R _{n1} N	R _{n2} N	η _d %	
				VFR 49												
	VFR 49_42	42	58	67	71	0.65	230	1920	76	33	78	0.37	230	2500	74	179
	VFR 49_54	54	54	52	68	0.50	230	2180	74	25.9	74	0.28	230	2830	71	
	VFR 49_72	72	49	39	68	0.40	230	2470	70	19.4	74	0.22	230	3190	67	
	VFR 49_84	84	42	33	82	0.44	230	2520	66	16.6	88	0.25	230	3290	62	
	VFR 49_108	108	38	25.9	75	0.33	230	2860	62	12.9	80	0.19	230	3450	58	
	VFR 49_135	135	34	20.7	71	0.27	230	3160	58	10.3	88	0.18	230	3450	54	
	VFR 49_180	180	29	15.6	64	0.20	230	3300	52	7.7	69	0.12	230	3450	48	
	VFR 49_210	210	27	13.3	60	0.17	230	3300	49	6.6	69	0.11	230	3450	45	
	VFR 49_240	240	25	11.7	58	0.15	230	3300	46	5.8	59	0.09	230	3450	42	
	VFR 49_300	300	22	9.3	52	0.12	230	3300	41	4.7	59	0.08	230	3450	37	
				n ₁ = 900 min ⁻¹						n ₁ = 500 min ⁻¹						
	VFR 49_42	42	58	21.4	82	0.26	230	2960	72	11.9	90	0.16	230	3450	70	179
	VFR 49_54	54	54	16.7	79	0.20	230	3330	69	9.3	83	0.12	230	3450	67	
	VFR 49_72	72	49	12.5	79	0.16	230	3450	64	6.9	83	0.10	230	3450	62	
	VFR 49_84	84	42	10.7	91	0.17	230	3450	59	6.0	95	0.10	230	3450	57	
	VFR 49_108	108	38	8.3	84	0.13	230	3450	55	4.6	90	0.08	230	3450	52	
	VFR 49_135	135	34	6.7	82	0.11	230	3450	50	3.7	90	0.07	230	3450	48	
	VFR 49_180	180	29	5.0	75	0.09	230	3450	45	2.8	78	0.05	230	3450	42	
	VFR 49_210	210	27	4.3	75	0.08	230	3450	41	2.4	78	0.05	230	3450	39	
	VFR 49_240	240	25	3.8	64	0.06	230	3450	39	2.1	68	0.04	230	3450	36	
	VFR 49_300	300	22	3.0	63	0.06	230	3450	34	1.7	65	0.04	230	3450	32	



VF/VF 30/49

100 Nm

		i	η _s %	n ₁ = 1400 min ⁻¹						n ₁ = 900 min ⁻¹						
				n ₂ min ⁻¹	M _{n2} Nm	P _{n1} kW	R _{n1} N	R _{n2} N	η _d %	n ₂ min ⁻¹	M _{n2} Nm	P _{n1} kW	R _{n1} N	R _{n2} N	η _d %	
				VF/VF 30/49												
	VF/VF 30/49_240	240	32	5.8	95	0.13	80	3450	45	3.8	100	0.09	150	3450	44	180
	VF/VF 30/49_315	315	24	4.4	95	0.11	140	3450	40	2.9	100	0.07	150	3450	43	
	VF/VF 30/49_420	420	24	3.3	95	0.08	—	3450	41	2.1	100	0.06	—	3450	37	
	VF/VF 30/49_540	540	22	2.6	95	0.07	—	3450	37	1.7	100	0.05	—	3450	35	
	VF/VF 30/49_720	720	20	1.9	95	0.05	—	3450	39	1.3	100	0.04	—	3450	33	
	VF/VF 30/49_900	900	18	1.6	95	0.05	—	3450	31	1.0	100	0.04	—	3450	26	
	VF/VF 30/49_1120	1120	15	1.3	95	0.04	—	3450	31	0.80	100	0.03	—	3450	28	
	VF/VF 30/49_1440	1440	14	0.97	95	0.04	—	3450	24	0.63	100	0.03	—	3450	22	
	VF/VF 30/49_2160	2160	11	0.65	95	0.03	—	3450	21	0.42	100	0.02	—	3450	22	
	VF/VF 30/49_2700	2700	10	0.52	95	0.03	—	3450	17	0.33	100	0.02	—	3450	17	

(-) Contatar a nuestro servicio técnico, comunicando los datos relativos a la carga radial (sentido de giro, orientación y posición)



W 63 - WR 63

190 Nm

		i	η _s %	n ₁ = 2800 min ⁻¹					n ₁ = 1400 min ⁻¹							
				n ₂ min ⁻¹	M _{n2} Nm	P _{n1} kW	R _{n1} N	R _{n2} N	η _d %	n ₂ min ⁻¹	M _{n2} Nm	P _{n1} kW	R _{n1} N		R _{n2} N	η _d %
				W 63												
178	W 63_7	7	70	400	105	4.9	480	1010	90	200	120	2.9	480	1550	88	
	W 63_10	10	66	280	125	4.2	370	1360	88	140	140	2.4	480	1840	86	
	W 63_12	12	63	233	125	3.5	435	1540	87	117	140	2.0	480	2070	85	
	W 63_15	15	59	187	125	2.8	410	1770	86	93	150	1.8	480	2280	83	
	W 63_19	19	55	147	130	2.4	310	1990	84	74	150	1.4	480	2600	81	
	W 63_24	24	52	117	130	1.9	370	2250	82	58	155	1.2	480	2890	78	
	W 63_30	30	44	93	125	1.6	440	2540	78	47	160	1.1	460	3170	74	
	W 63_38	38	40	74	130	1.3	330	2800	75	37	155	0.85	480	3580	70	
	W 63_45	45	37	62	130	1.2	380	3020	73	31	145	0.71	480	3920	67	
	W 63_64	64	31	44	110	0.75	480	3650	67	21.9	125	0.47	480	4680	61	
W 63_80	80	27	35	100	0.59	480	4050	62	17.5	115	0.38	480	5000	56		
W 63_100	100	23	28	100	0.51	480	4420	58	14.0	115	0.33	480	5000	51		
				n ₁ = 900 min ⁻¹					n ₁ = 500 min ⁻¹							
178	W 63_7	7	70	129	130	2.0	480	1870	87	71	140	1.2	480	2420	84	
	W 63_10	10	66	90	150	1.7	480	2220	84	50	165	1.1	480	2830	81	
	W 63_12	12	63	75	150	1.4	480	2480	82	42	165	0.92	480	3140	79	
	W 63_15	15	59	60	160	1.3	480	2740	80	33	180	0.83	480	3430	76	
	W 63_19	19	55	47	160	1.0	480	3100	78	26.3	180	0.68	480	3860	73	
	W 63_24	24	52	38	165	0.86	480	3440	75	20.8	185	0.58	480	4280	70	
	W 63_30	30	44	30	170	0.76	480	3770	70	16.7	190	0.52	480	4690	64	
	W 63_38	38	40	23.7	165	0.62	480	4240	66	13.2	185	0.42	480	5000	61	
	W 63_45	45	37	20.0	155	0.52	480	4630	63	11.1	170	0.34	480	5000	58	
	W 63_64	64	31	14.1	135	0.35	480	5000	56	7.8	150	0.24	480	5000	51	
W 63_80	80	27	11.3	125	0.28	480	5000	52	6.3	135	0.19	480	5000	46		
W 63_100	100	23	9.0	120	0.25	480	5000	46	5.0	130	0.17	480	5000	41		



220 Nm

		i	η _s %	n ₁ = 2800 min ⁻¹					n ₁ = 1400 min ⁻¹							
				n ₂ min ⁻¹	M _{n2} Nm	P _{n1} kW	R _{n1} N	R _{n2} N	η _d %	n ₂ min ⁻¹	M _{n2} Nm	P _{n1} kW	R _{n1} N		R _{n2} N	η _d %
				WR 63												
179	WR 63_21	21	69	133	130	2.1	180	1840	87	67	140	1.2	320	2510	84	
	WR 63_30	30	65	93	150	1.7	300	2180	84	47	165	1.0	320	2920	81	
	WR 63_36	36	62	78	150	1.5	320	2430	82	39	165	0.85	320	3240	79	
	WR 63_45	45	58	62	160	1.3	320	2690	80	31	180	0.77	320	3540	76	
	WR 63_57	57	54	49	160	1.1	320	3050	78	24.6	180	0.63	320	3980	73	
	WR 63_72	72	51	39	165	0.90	320	3390	75	19.4	185	0.54	320	4410	70	
	WR 63_90	90	44	31	170	0.79	320	3710	70	15.6	190	0.48	320	4830	64	
	WR 63_114	114	39	24.6	165	0.62	320	4170	68	12.3	185	0.39	320	5000	61	
	WR 63_135	135	36	20.7	155	0.53	320	4560	63	10.4	170	0.32	320	5000	58	
	WR 63_192	192	30	14.6	135	0.37	320	5000	56	7.3	150	0.22	320	5000	51	
WR 63_240	240	26	11.7	125	0.29	320	5000	52	5.8	135	0.18	320	5000	46		
WR 63_300	300	22	9.3	120	0.25	320	5000	46	4.7	130	0.15	320	5000	41		
				n ₁ = 900 min ⁻¹					n ₁ = 500 min ⁻¹							
179	WR 63_21	21	69	43	155	0.85	320	2960	82	23.8	170	0.53	320	3750	80	
	WR 63_30	30	65	30	180	0.72	320	3470	79	16.7	200	0.45	320	4360	77	
	WR 63_36	36	62	25.0	180	0.61	320	3830	77	14.0	200	0.40	320	4790	74	
	WR 63_45	45	58	20.0	190	0.54	320	4230	74	11.1	200	0.33	320	5000	71	
	WR 63_57	57	54	15.8	190	0.44	320	4740	71	8.8	200	0.27	320	5000	68	
	WR 63_72	72	51	12.5	190	0.37	320	5000	68	6.9	190	0.22	320	5000	64	
	WR 63_90	90	44	10.0	205	0.35	320	5000	62	5.6	220	0.22	320	5000	58	
	WR 63_114	114	39	7.9	200	0.29	320	5000	58	4.4	210	0.18	320	5000	54	
	WR 63_135	135	36	6.7	180	0.23	320	5000	54	3.7	190	0.15	320	5000	50	
	WR 63_192	192	30	4.7	150	0.16	320	5000	47	2.6	150	0.10	320	5000	43	
WR 63_240	240	26	3.8	140	0.13	320	5000	43	2.1	140	0.08	320	5000	39		
WR 63_300	300	22	3.0	130	0.11	320	5000	38	1.7	130	0.07	320	5000	34		



VF/W 30/63

230 Nm

		i	η _s %	n ₁ = 1400 min ⁻¹						n ₁ = 900 min ⁻¹						
				n ₂ min ⁻¹	M _{n2} Nm	P _{n1} kW	R _{n1} N	R _{n2} N	η _d %	n ₂ min ⁻¹	M _{n2} Nm	P _{n1} kW	R _{n1} N	R _{n2} N	η _d %	
				VF/W 30/63												
	VF/W 30/63_240	240	33	5.8	210	0.27	80	5000	47	3.8	230	0.20	150	5000	45	180
	VF/W 30/63_315	315	26	4.4	210	0.23	140	5000	42	2.9	230	0.17	150	5000	41	
	VF/W 30/63_450	450	25	3.1	210	0.17	—	5000	41	2.0	230	0.11	—	5000	42	
	VF/W 30/63_570	570	22	2.5	210	0.14	—	5000	40	1.6	230	0.11	—	5000	36	
	VF/W 30/63_720	720	21	1.9	210	0.12	—	5000	37	1.3	230	0.09	—	5000	32	
	VF/W 30/63_900	900	18	1.6	210	0.11	—	5000	30	1.0	230	0.08	—	5000	29	
	VF/W 30/63_1200	1200	16	1.2	210	0.11	—	5000	24	0.75	230	0.07	—	5000	25	
	VF/W 30/63_1520	1520	14	0.92	210	0.08	—	5000	24	0.59	230	0.06	—	5000	23	
	VF/W 30/63_2280	2280	12	0.61	210	0.06	—	5000	21	0.39	230	0.04	—	5000	23	
	VF/W 30/63_2700	2700	11	0.52	210	0.05	—	5000	22	0.33	230	0.04	—	5000	19	

(-) Contactar a nuestro servicio técnico, comunicando los datos relativos a la carga radial (sentido de giro, orientación y posición)



W 75 - WR 75

320 Nm

		i	η _s %	n ₁ = 2800 min ⁻¹						n ₁ = 1400 min ⁻¹							
				n ₂ min ⁻¹	M _{n2} Nm	P _{n1} kW	R _{n1} N	R _{n2} N	η _d %	n ₂ min ⁻¹	M _{n2} Nm	P _{n1} kW	R _{n1} N	R _{n2} N	η _d %		
W 75	W 75_7	7	71	400	170	7.8	750	700	91	200	190	4.4	750	1530	90	178	
	W 75_10	10	67	280	205	6.7	750	1610	90	140	230	3.8	750	2240	88		
	W 75_15	15	60	187	225	5.0	750	2120	88	93	250	2.9	750	2870	85		
	W 75_20	20	56	140	225	3.8	750	2550	86	70	250	2.2	750	3410	83		
	W 75_25	25	52	112	225	3.2	750	2900	83	56	250	1.8	750	3840	80		
	W 75_30	30	45	93	240	2.9	750	3100	81	47	270	1.7	750	4090	77		
	W 75_40	40	40	70	225	2.1	750	3660	77	35	255	1.3	750	4770	72		
	W 75_50	50	36	56	195	1.6	750	4180	73	28.0	220	0.95	750	5410	68		
	W 75_60	60	33	47	180	1.3	750	4610	70	23.3	200	0.75	750	5960	65		
	W 75_80	80	28	35	160	0.90	750	5310	65	17.5	180	0.56	750	6200	59		
W 75_100	100	25	28.0	135	0.65	750	5960	61	14.0	150	0.40	750	6200	55			
				n ₁ = 900 min ⁻¹						n ₁ = 500 min ⁻¹							
W 75	W 75_7	7	71	129	205	3.1	750	2120	88	71	225	2.0	750	2940	86	178	
	W 75_10	10	67	90	250	2.7	750	2700	86	50	275	1.7	750	3480	84		
	W 75_15	15	60	60	270	2.0	750	3440	83	33	295	1.3	750	4380	80		
	W 75_20	20	56	45	270	1.6	750	4050	80	25.0	295	1.0	750	5120	77		
	W 75_25	25	52	36	270	1.3	750	4550	77	20.0	295	0.85	750	5720	73		
	W 75_30	30	45	30	290	1.2	750	4860	74	16.7	320	0.81	750	6080	69		
	W 75_40	40	40	22.5	275	1.0	750	5630	68	12.5	305	0.63	750	6200	63		
	W 75_50	50	36	18.0	235	0.70	750	6200	63	10.0	260	0.47	750	6200	58		
	W 75_60	60	33	15.0	215	0.56	750	6200	60	8.3	235	0.37	750	6200	55		
	W 75_80	80	28	11.3	195	0.43	750	6200	54	6.3	215	0.29	750	6200	49		
W 75_100	100	25	9.0	160	0.30	750	6200	50	5.0	180	0.21	750	6200	44			

420 Nm

		i	η _s %	n ₁ = 2800 min ⁻¹						n ₁ = 1400 min ⁻¹							
				n ₂ min ⁻¹	M _{n2} Nm	P _{n1} kW	R _{n1} N	R _{n2} N	η _d %	n ₂ min ⁻¹	M _{n2} Nm	P _{n1} kW	R _{n1} N	R _{n2} N	η _d %		
WR 75	WR 75_21	21	70	133	205	3.3	500	2030	88	67	225	1.8	500	3060	86	179	
	WR 75_30	30	66	93	250	2.8	500	2640	86	47	275	1.6	500	3610	84		
	WR 75_45	45	59	62	270	2.1	500	3380	83	31	295	1.2	500	4530	80		
	WR 75_60	60	55	47	270	1.6	500	3980	80	23.3	295	0.94	500	5280	77		
	WR 75_75	75	51	37	270	1.4	500	4480	77	18.7	295	0.79	500	5890	73		
	WR 75_90	90	44	31	290	1.3	500	4780	74	15.6	320	0.76	500	6200	69		
	WR 75_120	120	39	23.3	275	1.0	500	5540	68	11.7	305	0.59	500	6200	63		
	WR 75_150	150	35	18.7	235	0.73	500	6200	63	9.3	260	0.44	500	6200	58		
	WR 75_180	180	32	15.6	215	0.58	500	6200	60	7.8	235	0.35	500	6200	55		
	WR 75_240	240	27	11.7	195	0.44	500	6200	54	5.8	215	0.27	500	6200	49		
WR 75_300	300	24	9.3	160	0.31	500	6200	50	4.7	180	0.20	500	6200	44			
				n ₁ = 900 min ⁻¹						n ₁ = 500 min ⁻¹							
WR 75	WR 75_21	21	70	43	245	1.3	500	3660	85	23.8	270	0.82	500	4660	82	179	
	WR 75_30	30	66	30	330	1.3	500	4070	82	16.7	370	0.81	500	5160	80		
	WR 75_45	45	59	20.0	350	0.94	500	5180	78	11.1	400	0.62	500	6200	75		
	WR 75_60	60	55	15.0	330	0.69	500	6180	75	8.3	370	0.45	500	6200	71		
	WR 75_75	75	51	12.0	330	0.59	500	6200	70	6.7	350	0.37	500	6200	66		
	WR 75_90	90	44	10.0	370	0.58	500	6200	67	5.6	420	0.39	500	6200	63		
	WR 75_120	120	39	7.5	330	0.43	500	6200	60	4.2	380	0.30	500	6200	56		
	WR 75_150	150	35	6.0	310	0.35	500	6200	55	3.3	350	0.24	500	6200	51		
	WR 75_180	180	32	5.0	280	0.29	500	6200	51	2.8	320	0.20	500	6200	47		
	WR 75_240	240	27	3.8	220	0.19	500	6200	45	2.1	280	0.15	500	6200	41		
WR 75_300	300	24	3.0	200	0.15	500	6200	41	1.7	260	0.12	500	6200	37			



WR 75 - VF/W 44/75

370 Nm

WR 75_P90 B5			i	η_s %	$n_1 = 2800 \text{ min}^{-1}$					$n_1 = 1400 \text{ min}^{-1}$								
					n_2 min ⁻¹	M_{n2} Nm	P_{n1} kW	R_{n1} N	R_{n2} N	η_d %	n_2 min ⁻¹	M_{n2} Nm	P_{n1} kW	R_{n1} N		R_{n2} N	η_d %	
WR 75_P90 B5					$n_1 = 2800 \text{ min}^{-1}$					$n_1 = 1400 \text{ min}^{-1}$					179			
			WR 75_15	15	66	187	220	4.9	—	1960	89	93	250	2.9		—	2640	86
			WR 75_22.5	22.5	59	124	240	3.7	—	2530	86	62	270	2.1		—	3380	83
			WR 75_30	30	55	93	240	2.8	—	3020	84	47	270	1.7		—	3980	80
			WR 75_37.5	37.5	51	75	240	2.3	—	3410	81	37	270	1.4		—	4480	77
			WR 75_45	45	44	62	255	2.1	—	3660	79	31	290	1.3		—	4780	74
			WR 75_60	60	39	47	240	1.6	—	4290	74	23.3	275	1.0		—	5540	68
			WR 75_75	75	35	37	210	1.2	—	4860	70	18.7	235	0.74		—	6200	63
			WR 75_90	90	32	31	190	0.93	—	4460	67	15.6	215	0.59		—	6200	60
WR 75_120	120	27	23.3	170	0.69	—	4960	61	11.7	195	0.44	—	6200	54				
WR 75_150	150	24	18.7	145	0.49	—	5150	58	9.3	160	0.32	—	6200	50				
					$n_1 = 900 \text{ min}^{-1}$					$n_1 = 500 \text{ min}^{-1}$								
WR 75_P90 B5					$n_1 = 900 \text{ min}^{-1}$					$n_1 = 500 \text{ min}^{-1}$					179			
			WR 75_15	15	66	60	275	2.1	—	3150	84	33	330	1.4		—	3850	82
			WR 75_22.5	22.5	59	40	295	1.6	—	4010	80	22.2	350	1.0		—	4920	78
			WR 75_30	30	55	30	295	1.2	—	4710	77	16.7	330	0.77		—	5890	75
			WR 75_37.5	37.5	51	24	295	1.0	—	5280	73	13.3	330	0.66		—	6200	70
			WR 75_45	45	44	20	320	0.98	—	5610	69	11.1	370	0.64		—	6200	67
			WR 75_60	60	39	15	305	0.77	—	6200	63	8.3	330	0.48		—	6200	60
			WR 75_75	75	35	12	260	0.57	—	6200	58	6.7	310	0.39		—	6200	55
			WR 75_90	90	32	10	235	0.45	—	6200	55	5.6	280	0.32		—	6200	52
WR 75_120	120	27	7.5	215	0.35	—	6200	49	4.2	220	0.21	—	6200	46				
WR 75_150	150	24	6.0	180	0.26	—	6200	44	3.3	200	0.17	—	6200	41				

400 Nm

VF/W 44/75			i	η_s %	$n_1 = 1400 \text{ min}^{-1}$					$n_1 = 900 \text{ min}^{-1}$								
					n_2 min ⁻¹	M_{n2} Nm	P_{n1} kW	R_{n1} N	R_{n2} N	η_d %	n_2 min ⁻¹	M_{n2} Nm	P_{n1} kW	R_{n1} N		R_{n2} N	η_d %	
VF/W 44/75					$n_1 = 1400 \text{ min}^{-1}$					$n_1 = 900 \text{ min}^{-1}$					180			
			VF/W 44/75_250	250	34	5.6	370	0.38	220	4560	57	3.6	400	0.29		220	4660	52
			VF/W 44/75_300	300	30	4.7	370	0.35	220	5160	51	3.0	400	0.27		220	5150	46
			VF/W 44/75_400	400	26	3.5	370	0.29	220	6200	46	2.3	400	0.22		220	6200	42
			VF/W 44/75_525	525	25	2.7	370	0.23	220	6200	44	1.7	400	0.18		220	6200	41
			VF/W 44/75_700	700	24	2.0	370	0.18	220	6200	42	1.3	400	0.14		220	6200	39
			VF/W 44/75_920	920	21	1.5	370	0.15	—	6200	40	1.0	400	0.11		60	6200	36
			VF/W 44/75_1200	1200	18	1.2	370	0.12	—	6200	37	0.75	400	0.10		220	6200	31
			VF/W 44/75_1500	1500	17	0.93	370	0.10	220	6200	37	0.60	400	0.09		220	6200	29
VF/W 44/75_2100	2100	14	0.67	370	0.09	220	6200	30	0.43	400	0.07	220	6200	24				
VF/W 44/75_2800	2800	12	0.50	370	0.07	220	6200	26	0.32	400	0.06	220	6200	22				

(-) Contactar a nuestro servicio técnico, comunicando los datos relativos a la carga radial (sentido de giro, orientación y posición)



W 86 - WR 86

440 Nm

	i	η_s %	$n_1 = 2800 \text{ min}^{-1}$							$n_1 = 1400 \text{ min}^{-1}$							
			n_2 min ⁻¹	M_{n2} Nm	P_{n1} kW	R_{n1} N	R_{n2} N	η_d %	n_2 min ⁻¹	M_{n2} Nm	P_{n1} kW	R_{n1} N	R_{n2} N	η_d %			
			W 86														
W 86_7	7	71	400	225	10.4	850	2930	91	200	250	5.9	850	3920	89	178		
W 86_10	10	67	280	260	8.5	850	3490	90	140	290	4.8	850	4620	88			
W 86_15	15	60	187	295	6.6	850	4200	87	93	330	3.8	850	5510	85			
W 86_20	20	60	140	285	4.9	850	4900	86	70	320	2.8	850	6380	84			
W 86_23	23	58	122	285	4.3	850	5250	85	61	320	2.5	850	6800	82			
W 86_30	30	45	93	320	3.9	850	5740	81	47	370	2.4	850	7000	76			
W 86_40	40	45	70	295	2.7	850	6670	79	35	330	1.6	850	7000	75			
W 86_46	46	43	61	305	2.5	850	7000	77	30	340	1.5	850	7000	73			
W 86_56	56	39	50	265	1.8	850	7000	75	25.0	300	1.1	850	7000	70			
W 86_64	64	37	44	250	1.6	850	7000	73	21.9	280	0.94	850	7000	68			
W 86_80	80	33	35	225	1.2	850	7000	69	17.5	255	0.73	850	7000	64			
W 86_100	100	29	28.0	205	0.92	850	7000	65	14.0	230	0.57	850	7000	59			
			$n_1 = 900 \text{ min}^{-1}$							$n_1 = 500 \text{ min}^{-1}$							
W 86_7	7	71	129	270	4.1	850	4670	88	71	295	2.6	850	5890	85	178		
W 86_10	10	67	90	310	3.4	850	5500	86	50	345	2.2	850	6860	82			
W 86_15	15	60	60	355	2.7	850	6520	82	33	390	1.7	850	7000	78			
W 86_20	20	60	45	345	2.0	850	7000	81	25.0	380	1.3	850	7000	77			
W 86_23	23	58	39	345	1.8	850	7000	80	21.7	380	1.2	850	7000	75			
W 86_30	30	45	30	400	1.7	850	7000	73	16.7	440	1.1	850	7000	67			
W 86_40	40	45	22.5	355	1.2	850	7000	71	12.5	390	0.77	850	7000	66			
W 86_46	46	43	19.6	365	1.1	850	7000	69	10.9	405	0.73	850	7000	63			
W 86_56	56	39	16.1	325	0.83	850	7000	66	8.9	355	0.55	850	7000	60			
W 86_64	64	37	14.1	300	0.70	850	7000	63	7.8	330	0.47	850	7000	58			
W 86_80	80	33	11.3	275	0.55	850	7000	59	6.3	305	0.38	850	7000	53			
W 86_100	100	29	9.0	250	0.43	850	7000	55	5.0	275	0.29	850	7000	49			

550 Nm

	i	η_s %	$n_1 = 2800 \text{ min}^{-1}$							$n_1 = 1400 \text{ min}^{-1}$							
			n_2 min ⁻¹	M_{n2} Nm	P_{n1} kW	R_{n1} N	R_{n2} N	η_d %	n_2 min ⁻¹	M_{n2} Nm	P_{n1} kW	R_{n1} N	R_{n2} N	η_d %			
			WR 86														
WR 86_21	21	70	133	270	4.3	500	4590	88	67	295	2.4	500	6070	85	179		
WR 86_30	30	66	93	310	3.5	500	5410	86	47	345	2.1	500	7000	82			
WR 86_45	45	59	62	355	2.8	500	6420	82	31	390	1.6	500	7000	78			
WR 86_60	60	59	47	345	2.1	500	7000	81	23.3	380	1.2	500	7000	77			
WR 86_69	69	57	41	345	1.8	500	7000	80	20.3	380	1.1	500	7000	75			
WR 86_90	90	44	31	400	1.8	500	7000	73	15.6	440	1.1	500	7000	67			
WR 86_120	120	44	23.3	355	1.2	500	7000	71	11.7	390	0.72	500	7000	66			
WR 86_138	138	42	20.3	365	1.1	500	7000	69	10.1	405	0.68	500	7000	63			
WR 86_168	168	38	16.7	325	0.86	500	7000	66	8.3	355	0.52	500	7000	60			
WR 86_192	192	36	14.6	300	0.73	500	7000	63	7.3	330	0.43	500	7000	58			
WR 86_240	240	32	11.7	275	0.57	500	7000	59	5.8	305	0.35	500	7000	53			
WR 86_300	300	28	9.3	250	0.44	500	7000	55	4.7	275	0.27	500	7000	49			
			$n_1 = 900 \text{ min}^{-1}$							$n_1 = 500 \text{ min}^{-1}$							
WR 86_21	21	70	43	325	1.8	500	7000	83	23.8	355	1.1	500	7000	81	179		
WR 86_30	30	66	30	375	1.5	500	7000	81	16.7	415	0.93	500	7000	78			
WR 86_45	45	59	20.0	450	1.2	500	7000	76	11.1	500	0.80	500	7000	73			
WR 86_60	60	59	15.0	430	0.90	500	7000	75	8.3	440	0.53	500	7000	72			
WR 86_69	69	57	13.0	390	0.73	500	7000	73	7.2	400	0.43	500	7000	70			
WR 86_90	90	44	10.0	500	0.82	500	7000	64	5.6	550	0.53	500	7000	60			
WR 86_120	120	44	7.5	440	0.55	500	7000	63	4.2	470	0.35	500	7000	59			
WR 86_138	138	42	6.5	430	0.48	500	7000	61	3.6	440	0.30	500	7000	56			
WR 86_168	168	38	5.4	390	0.38	500	7000	57	3.0	410	0.24	500	7000	53			
WR 86_192	192	36	4.7	390	0.35	500	7000	55	2.6	410	0.22	500	7000	50			
WR 86_240	240	32	3.8	310	0.24	500	7000	50	2.1	320	0.15	500	7000	46			
WR 86_300	300	28	3.0	310	0.22	500	7000	45	1.7	320	0.14	500	7000	41			



WR 86 - VF/W 44/86

500 Nm



	i	η_s %	$n_1 = 2800 \text{ min}^{-1}$						$n_1 = 1400 \text{ min}^{-1}$						
			n_2 min ⁻¹	M_{n2} Nm	P_{n1} kW	R_{n1} N	R_{n2} N	η_d %	n_2 min ⁻¹	M_{n2} Nm	P_{n1} kW	R_{n1} N	R_{n2} N	η_d %	
			WR 86_P90_B5												
WR 86_15	15	66	187	275	6.1	—	4130	88	93	310	3.5	—	5410	86	179
WR 86_22.5	22.5	59	124	315	4.8	—	4920	86	62	355	2.8	—	6420	82	
WR 86_30	30	59	93	305	3.5	—	5720	85	47	345	2.1	—	7000	81	
WR 86_34.5	34.5	57	81	305	3.1	—	6110	84	41	345	1.8	—	7000	80	
WR 86_45	45	44	62	350	3.0	—	6640	77	31	400	1.8	—	7000	73	
WR 86_60	60	44	47	315	2.0	—	7000	77	23.3	355	1.2	—	7000	71	
WR 86_69	69	42	41	325	1.8	—	7000	75	20.3	365	1.1	—	7000	69	
WR 86_84	84	38	33	285	1.4	—	7000	72	16.7	325	0.86	—	7000	66	
WR 86_96	96	36	29.2	265	1.2	—	7000	70	14.6	300	0.73	—	7000	63	
WR 86_120	120	32	23.3	240	0.88	—	7000	67	11.7	275	0.57	—	7000	59	
WR 86_150	150	28	18.7	220	0.69	—	7000	62	9.3	250	0.44	—	7000	55	
			$n_1 = 900 \text{ min}^{-1}$						$n_1 = 500 \text{ min}^{-1}$						
WR 86_15	15	66	60	345	2.6	—	6330	82	33	375	1.6	—	7000	81	179
WR 86_22.5	22.5	59	40	390	2.1	—	7000	78	22.2	450	1.4	—	7000	76	
WR 86_30	30	59	30	380	1.6	—	7000	77	16.7	430	1.0	—	7000	75	
WR 86_34.5	34.5	57	26.1	380	1.4	—	7000	75	14.5	390	0.81	—	7000	73	
WR 86_45	45	44	20.0	440	1.4	—	7000	67	11.1	500	0.91	—	7000	64	
WR 86_60	60	44	15.0	390	0.93	—	7000	66	8.3	440	0.61	—	7000	63	
WR 86_69	69	42	13.0	405	0.88	—	7000	63	7.2	430	0.53	—	7000	61	
WR 86_84	84	38	10.7	355	0.66	—	7000	60	6.0	390	0.43	—	7000	57	
WR 86_96	96	36	9.4	330	0.56	—	7000	58	5.2	390	0.39	—	7000	55	
WR 86_120	120	32	7.5	305	0.45	—	7000	53	4.2	310	0.27	—	7000	50	
WR 86_150	150	28	6.0	275	0.35	—	7000	49	3.3	310	0.24	—	7000	46	

550 Nm



	i	η_s %	$n_1 = 1400 \text{ min}^{-1}$						$n_1 = 900 \text{ min}^{-1}$						
			n_2 min ⁻¹	M_{n2} Nm	P_{n1} kW	R_{n1} N	R_{n2} N	η_d %	n_2 min ⁻¹	M_{n2} Nm	P_{n1} kW	R_{n1} N	R_{n2} N	η_d %	
			VF/W 44/86												
VF/W 44/86_230	230	38	6.1	500	0.59	220	7000	54	3.9	550	0.43	220	7000	53	180
VF/W 44/86_300	300	30	4.7	500	0.54	220	7000	45	3.0	550	0.41	220	7000	42	
VF/W 44/86_400	400	30	3.5	500	0.45	220	7000	41	2.3	550	0.32	220	7000	41	
VF/W 44/86_525	525	25	2.7	500	0.33	220	7000	42	1.7	550	0.25	220	7000	39	
VF/W 44/86_700	700	25	2.0	500	0.27	220	7000	39	1.3	550	0.20	220	7000	37	
VF/W 44/86_920	920	22	1.5	500	0.20	220	7000	40	1.0	550	0.15	—	7000	37	
VF/W 44/86_1380	1380	17	1.0	500	0.17	220	7000	32	0.65	550	0.13	—	7000	28	
VF/W 44/86_1840	1840	17	0.76	500	0.13	220	7000	30	0.49	550	0.10	—	7000	28	
VF/W 44/86_2116	2116	16	0.66	500	0.12	220	7000	28	0.43	550	0.09	220	7000	28	
VF/W 44/86_2760	2760	14	0.51	500	0.11	—	7000	24	0.33	550	0.08	220	7000	24	

(-) Contactar a nuestro servicio técnico, comunicando los datos relativos a la carga radial (sentido de giro, orientación y posición)



W 110 - WR 110

830 Nm

W 110	i	η_s %	$n_1 = 2800 \text{ min}^{-1}$						$n_1 = 1400 \text{ min}^{-1}$						
			n_2 min ⁻¹	M_{n2} Nm	P_{n1} kW	R_{n1} N	R_{n2} N	η_d %	n_2 min ⁻¹	M_{n2} Nm	P_{n1} kW	R_{n1} N	R_{n2} N	η_d %	
W 110_7	7	71	400	445	20.7	1200	3710	90	200	500	11.8	1200	5020	89	178
W 110_10	10	67	280	490	16.1	1200	4650	89	140	550	9.3	1200	6190	87	
W 110_15	15	60	187	535	12.0	1200	5770	87	93	600	7.0	1200	7590	84	
W 110_20	20	61	140	510	8.7	1200	6790	86	70	570	5.0	1200	8000	84	
W 110_23	23	59	122	480	7.1	1200	7430	86	61	540	4.1	1200	8000	83	
W 110_30	30	45	93	625	7.5	1200	7780	81	47	700	4.4	1200	8000	77	
W 110_40	40	46	70	595	5.5	1200	8000	80	35	670	3.2	1200	8000	76	
W 110_46	46	44	61	535	4.3	1200	8000	79	30	600	2.6	1200	8000	74	
W 110_56	56	41	50	535	3.7	1200	8000	76	25.0	600	2.2	1200	8000	72	
W 110_64	64	38	44	470	2.9	1200	8000	74	21.9	530	1.7	1200	8000	70	
W 110_80	80	34	35	420	2.2	1200	8000	71	17.5	470	1.3	1200	8000	66	
W 110_100	100	30	28.0	410	1.8	1200	8000	67	14.0	460	1.1	1200	8000	62	
			$n_1 = 900 \text{ min}^{-1}$						$n_1 = 500 \text{ min}^{-1}$						
W 110_7	7	71	129	540	8.3	1200	6040	88	71	595	5.2	1200	7680	86	178
W 110_10	10	67	90	590	6.5	1200	7410	86	50	655	4.1	1200	8000	84	
W 110_15	15	60	60	645	4.9	1200	8000	83	33	710	3.1	1200	8000	80	
W 110_20	20	61	45	615	3.5	1200	8000	82	25.0	675	2.2	1200	8000	79	
W 110_23	23	59	39	580	2.9	1200	8000	81	21.7	640	1.9	1200	8000	77	
W 110_30	30	45	30	755	3.2	1200	8000	74	16.7	830	2.1	1200	8000	70	
W 110_40	40	46	22.5	720	2.3	1200	8000	73	12.5	795	1.5	1200	8000	68	
W 110_46	46	44	19.6	645	1.9	1200	8000	71	10.9	710	1.2	1200	8000	66	
W 110_56	56	41	16.1	645	1.6	1200	8000	68	8.9	710	1.1	1200	8000	63	
W 110_64	64	38	14.1	570	1.3	1200	8000	65	7.8	630	0.86	1200	8000	60	
W 110_80	80	34	11.3	505	0.98	1200	8000	61	6.3	560	0.65	1200	8000	56	
W 110_100	100	30	9.0	495	0.82	1200	8000	57	5.0	545	0.56	1200	8000	51	

1000 Nm

WR 110	i	η_s %	$n_1 = 2800 \text{ min}^{-1}$						$n_1 = 1400 \text{ min}^{-1}$						
			n_2 min ⁻¹	M_{n2} Nm	P_{n1} kW	R_{n1} N	R_{n2} N	η_d %	n_2 min ⁻¹	M_{n2} Nm	P_{n1} kW	R_{n1} N	R_{n2} N	η_d %	
WR 110_21	21	70	133	540	8.6	700	5930	88	67	595	4.8	700	7950	86	179
WR 110_30	30	66	93	590	6.7	700	7280	86	47	655	3.8	700	8000	84	
WR 110_45	45	59	62	645	5.1	700	8000	83	31	710	2.9	700	8000	80	
WR 110_60	60	60	47	615	3.7	700	8000	82	23.3	675	2.1	700	8000	79	
WR 110_69	69	58	41	580	3.0	700	8000	81	20.3	640	1.8	700	8000	77	
WR 110_90	90	44	31	755	3.3	700	8000	74	15.6	830	1.9	700	8000	70	
WR 110_120	120	45	23.3	720	2.4	700	8000	73	11.7	795	1.4	700	8000	68	
WR 110_138	138	43	20.3	645	1.9	700	8000	71	10.1	710	1.1	700	8000	66	
WR 110_168	168	40	16.7	645	1.7	700	8000	68	8.3	710	0.98	700	8000	63	
WR 110_192	192	37	14.6	570	1.3	700	8000	65	7.3	630	0.80	700	8000	60	
WR 110_240	240	33	11.7	505	1.0	700	8000	61	5.8	560	0.61	700	8000	56	
WR 110_300	300	29	9.3	495	0.85	700	8000	57	4.7	545	0.52	700	8000	51	
			$n_1 = 900 \text{ min}^{-1}$						$n_1 = 500 \text{ min}^{-1}$						
WR 110_21	21	70	43	645	3.4	700	8000	84	23.8	715	2.2	700	8000	82	179
WR 110_30	30	66	30	710	2.8	700	8000	81	16.7	785	1.7	700	8000	79	
WR 110_45	45	59	20.0	870	2.4	700	8000	77	11.1	950	1.5	700	8000	75	
WR 110_60	60	60	15.0	800	1.6	700	8000	77	8.3	850	1.0	700	8000	74	
WR 110_69	69	58	13.0	750	1.4	700	8000	75	7.2	820	0.86	700	8000	72	
WR 110_90	90	44	10.0	900	1.4	700	8000	66	5.6	1000	0.94	700	8000	62	
WR 110_120	120	45	7.5	870	1.1	700	8000	65	4.2	950	0.68	700	8000	61	
WR 110_138	138	43	6.5	800	0.87	700	8000	63	3.6	900	0.58	700	8000	59	
WR 110_168	168	40	5.4	775	0.72	700	8000	60	3.0	800	0.45	700	8000	55	
WR 110_192	192	37	4.7	685	0.59	700	8000	57	2.6	720	0.37	700	8000	53	
WR 110_240	240	33	3.8	590	0.44	700	8000	53	2.1	620	0.28	700	8000	48	
WR 110_300	300	29	3.0	570	0.37	700	8000	48	1.7	600	0.24	700	8000	44	



VF/W 49/110

1050 Nm



	i	η_s %	$n_1 = 1400 \text{ min}^{-1}$							$n_1 = 900 \text{ min}^{-1}$						
			n_2 min ⁻¹	M_{n2} Nm	P_{n1} kW	R_{n1} N	R_{n2} N	η_d %	n_2 min ⁻¹	M_{n2} Nm	P_{n1} kW	R_{n1} N	R_{n2} N	η_d %		
			VF/W 49/110	VF/W 49/110_230	230	38	6.1	1000	1.2	400	8000	52	3.9	1050		0.84
VF/W 49/110_300	300	29	4.7	1000	1.0	400	8000	48	3.0	1050	0.70	400	8000	47		
VF/W 49/110_400	400	30	3.5	1000	0.81	400	8000	45	2.3	1050	0.55	400	8000	45		
VF/W 49/110_540	540	25	2.6	1000	0.66	400	8000	41	1.7	1050	0.48	400	8000	38		
VF/W 49/110_720	720	24	1.9	1000	0.51	400	8000	40	1.3	1050	0.36	400	8000	38		
VF/W 49/110_1080	1080	18	1.3	1000	0.44	400	8000	31	0.83	1050	0.28	400	8000	30		
VF/W 49/110_1350	1350	16	1.0	1000	0.36	400	8000	30	0.67	1050	0.26	400	8000	28		
VF/W 49/110_1656	1656	17	0.85	1000	0.30	400	8000	30	0.54	1050	0.20	400	8000	30		
VF/W 49/110_2070	2070	15	0.68	1000	0.25	400	8000	28	0.43	1050	0.19	400	8000	25		
VF/W 49/110_2800	2800	13	0.50	1000	0.22	400	8000	24	0.32	1050	0.17	400	8000	21		



VF 130 - VFR 130

1500 Nm



	i	η_s %	$n_1 = 2800 \text{ min}^{-1}$							$n_1 = 1400 \text{ min}^{-1}$							
			n_2 min^{-1}	M_{n2} Nm	P_{n1} kW	R_{n1} N	R_{n2} N	η_d %	n_2 min^{-1}	M_{n2} Nm	P_{n1} kW	R_{n1} N	R_{n2} N	η_d %			
VF 130	VF 130_7	7	71	400	555	25	1500	4930	91	200	740	17.4	1500	5990	89	178	
	VF 130_10	10	67	280	593	19.3	1500	6210	90	140	790	13.3	1500	7620	88		
	VF 130_15	15	63	187	690	15.3	1500	7390	88	93	920	10.6	1500	9100	86		
	VF 130_20	20	59	140	675	11.4	1500	8670	87	70	900	8.0	1500	10700	84		
	VF 130_23	23	57	122	668	9.9	1500	9300	86	61	890	6.9	1500	11500	83		
	VF 130_30	30	49	93	788	9.3	1040	10100	83	47	1050	6.6	—	12500	79		
	VF 130_40	40	44	70	825	7.6	—	11400	80	35	1100	5.4	—	12600	76		
	VF 130_46	46	45	61	788	6.3	1290	12200	80	30.0	1050	4.5	—	12600	76		
	VF 130_56	56	42	50	720	4.8	1500	12600	78	25.0	960	3.4	940	12600	73		
	VF 130_64	64	39	44	698	4.2	1500	12600	76	21.9	930	3.0	1220	12600	71		
	VF 130_80	80	35	35	660	3.3	1500	12600	73	17.5	880	2.4	1500	12600	68		
VF 130_100	100	31	28	585	2.5	1500	12600	70	14.0	780	1.8	1500	12600	64			
			$n_1 = 900 \text{ min}^{-1}$							$n_1 = 500 \text{ min}^{-1}$							
VF 130	VF 130_7	7	71	129	850	13.0	1500	6980	88	71	1000	8.8	1500	8670	86	178	
	VF 130_10	10	67	90	900	9.9	1500	8900	87	50	1100	6.9	1500	10800	84		
	VF 130_15	15	63	60	1080	8.1	1500	10490	84	33	1350	5.9	1500	12600	81		
	VF 130_20	20	59	45	1050	6.1	1500	12400	82	25.0	1350	4.6	1500	13800	79		
	VF 130_23	23	57	39	1050	5.4	1500	13200	81	21.7	1300	3.9	1500	13800	77		
	VF 130_30	30	49	30.0	1250	5.2	—	13200	77	16.7	1500	3.7	—	13800	72		
	VF 130_40	40	44	22.5	1200	3.9	—	13200	73	12.5	1400	2.8	—	13800	68		
	VF 130_46	46	45	19.6	1150	3.3	490	13200	73	10.9	1350	2.3	1270	13800	68		
	VF 130_56	56	42	16.1	1080	2.7	1500	13200	70	8.9	1200	1.8	1500	13800	65		
	VF 130_64	64	39	14.1	1050	2.4	1500	13200	68	7.8	1200	1.6	1500	13800	62		
	VF 130_80	80	35	11.3	950	1.8	1500	13200	64	6.3	1150	1.3	1500	13800	58		
VF 130_100	100	31	9.0	800	1.3	1500	13200	59	5.0	900	0.91	1500	13800	54			

1800 Nm



	i	η_s %	$n_1 = 2800 \text{ min}^{-1}$							$n_1 = 1400 \text{ min}^{-1}$							
			n_2 min^{-1}	M_{n2} Nm	P_{n1} kW	R_{n1} N	R_{n2} N	η_d %	n_2 min^{-1}	M_{n2} Nm	P_{n1} kW	R_{n1} N	R_{n2} N	η_d %			
VFR 130	VFR 130_60	60	58	47	1050	6.4	1000	12400	81	23.3	1350	4.3	1000	13800	78	179	
	VFR 130_69	69	56	41	1050	5.6	1000	13200	80	20.3	1300	3.7	1000	13800	76		
	VFR 130_90	90	48	31	1250	5.4	1000	13200	76	15.6	1500	3.5	1000	13800	71		
	VFR 130_120	120	43	23.3	1200	4.1	1000	13200	72	11.7	1400	2.6	1000	13800	67		
	VFR 130_138	138	44	20.3	1150	3.4	1000	13200	72	10.1	1350	2.2	1000	13800	67		
	VFR 130_168	168	41	16.7	1080	2.7	1000	13200	69	8.3	1200	1.6	1000	13800	64		
	VFR 130_192	192	38	14.6	1050	2.4	1000	13200	67	7.3	1200	1.5	1000	13800	61		
	VFR 130_240	240	34	11.7	950	1.9	1000	13200	63	5.8	1150	1.2	1000	13800	57		
	VFR 130_300	300	30	9.3	800	1.4	1000	13200	58	4.7	900	0.83	1000	13800	53		
			$n_1 = 900 \text{ min}^{-1}$							$n_1 = 500 \text{ min}^{-1}$							
VFR 130	VFR 130_60	60	58	15.0	1450	3.1	1000	13800	75	8.3	1600	1.9	1000	13800	74	179	
	VFR 130_69	69	56	13.0	1450	2.7	1000	13800	74	7.2	1550	1.6	1000	13800	72		
	VFR 130_90	90	48	10.0	1600	2.5	1000	13800	68	5.6	1800	1.6	1000	13800	66		
	VFR 130_120	120	43	7.5	1600	2.0	1000	13800	63	4.2	1800	1.3	1000	13800	61		
	VFR 130_138	138	44	6.5	1500	1.6	1000	13800	64	3.6	1600	1.0	1000	13800	61		
	VFR 130_168	168	41	5.4	1350	1.3	1000	13800	60	3.0	1450	0.78	1000	13800	58		
	VFR 130_192	192	38	4.7	1300	1.1	1000	13800	58	2.6	1400	0.70	1000	13800	55		
	VFR 130_240	240	34	3.8	1200	0.87	1000	13800	54	2.1	1250	0.54	1000	13800	51		
	VFR 130_300	300	30	3.0	1000	0.64	1000	13800	49	1.7	1100	0.41	1000	13800	47		

(-) Contactar a nuestro servicio técnico, comunicando los datos relativos a la carga radial (sentido de giro, orientación y posición)



W/VF 63/130

1850 Nm



W/VF 63/130	i	η_s %	$n_1 = 1400 \text{ min}^{-1}$							$n_1 = 900 \text{ min}^{-1}$					
			n_2 min ⁻¹	M_{n2} Nm	P_{n1} kW	R_{n1} N	R_{n2} N	η_d %	n_2 min ⁻¹	M_{n2} Nm	P_{n1} kW	R_{n1} N	R_{n2} N	η_d %	
			W/VF 63/130_280	280	31	5.0	1800	1.9	480	13800	50	3.2	1850	1.3	
W/VF 63/130_400	400	29	3.5	1800	1.5	480	13800	44	2.3	1850	0.99	480	13800	44	
W/VF 63/130_600	600	26	2.3	1800	1.1	480	13800	40	1.5	1850	0.73	480	13800	40	
W/VF 63/130_760	760	24	1.8	1800	0.89	480	13800	39	1.2	1850	0.62	480	13800	37	
W/VF 63/130_960	960	23	1.5	1800	0.74	480	13800	37	0.94	1850	0.52	480	13800	35	
W/VF 63/130_1200	1200	19	1.2	1800	0.65	—	13800	34	0.75	1850	0.45	—	13800	32	
W/VF 63/130_1520	1520	18	0.92	1800	0.55	—	13800	32	0.59	1850	0.38	—	13800	30	
W/VF 63/130_1800	1800	16	0.78	1800	0.52	—	13800	28	0.50	1850	0.37	—	13800	26	
W/VF 63/130_2560	2560	14	0.55	1800	0.45	—	13800	23	0.35	1850	0.32	—	13800	21	
W/VF 63/130_3200	3200	12	0.44	1800	0.49	—	13800	17	0.28	1850	0.34	480	13800	16	

(-) Contatar a nuestro servicio técnico, comunicando los datos relativos a la carga radial (sentido de giro, orientación y posición)



VF 150 - VFR 150

2000 Nm

	i	η_s %	n_2	M_{n2}	P_{n1}	R_{n1}	R_{n2}	η_d	n_2	M_{n2}	P_{n1}	R_{n1}	R_{n2}	η_d		
			min ⁻¹	Nm	kW	N	N	%	min ⁻¹	Nm	kW	N	N	%		
			$n_1 = 2800 \text{ min}^{-1}$							$n_1 = 1400 \text{ min}^{-1}$						
VF 150	VF 150_7	7	72	400	750	35	2200	5010	91	200	1000	24	2200	6040	90	178
	VF 150_10	10	68	280	788	25	2200	6630	90	140	1050	17.5	2200	8120	88	
	VF 150_15	15	64	187	863	19.0	2200	8110	89	93	1150	13.1	2200	9990	87	
	VF 150_20	20	59	140	975	16.4	2200	9170	87	70	1300	11.3	2200	11300	84	
	VF 150_23	23	57	122	953	14.1	2200	9940	86	61	1270	9.8	2200	12300	83	
	VF 150_30	30	48	93	1028	12.1	2200	11100	83	47	1370	8.5	2200	13700	80	
	VF 150_40	40	44	70	1155	10.5	2200	12300	81	35	1540	7.4	830	14700	77	
	VF 150_46	46	45	61	1163	9.2	2200	13100	81	30.0	1550	6.5	1400	14700	77	
	VF 150_56	56	42	50	1028	6.8	2200	14600	79	25.0	1370	4.9	2200	14700	74	
	VF 150_64	64	39	44	998	5.9	2200	14700	77	21.9	1330	4.2	2200	14700	72	
	VF 150_80	80	35	35	938	4.6	2200	14700	74	17.5	1250	3.4	2200	14700	69	
VF 150_100	100	31	28	863	3.6	2200	14700	71	14.0	1150	2.6	2200	14700	65		
			$n_1 = 900 \text{ min}^{-1}$							$n_1 = 500 \text{ min}^{-1}$						
VF 150	VF 150_7	7	72	129	1150	17.6	2200	7040	89	71	1400	12.2	2200	8560	87	178
	VF 150_10	10	68	90	1200	13.0	2200	9480	87	50	1500	9.4	2200	11400	85	
	VF 150_15	15	64	60	1350	10.0	2200	11500	85	33	1700	7.3	2200	13800	83	
	VF 150_20	20	59	45	1500	8.6	2200	13100	83	25.0	1900	6.4	2200	15700	80	
	VF 150_23	23	57	39	1500	7.6	2200	14200	82	21.7	1850	5.5	2200	16000	78	
	VF 150_30	30	48	30.0	1600	6.5	2200	15500	77	16.7	1950	4.8	2200	16000	73	
	VF 150_40	40	44	22.5	1750	5.6	1150	15500	74	12.5	2000	3.9	2200	16000	69	
	VF 150_46	46	45	19.6	1750	4.9	2100	15500	74	10.9	2000	3.4	2200	16000	69	
	VF 150_56	56	42	16.1	1500	3.7	2200	15500	71	8.9	1750	2.6	2200	16000	66	
	VF 150_64	64	39	14.1	1450	3.2	2200	15500	69	7.8	1700	2.3	2200	16000	63	
	VF 150_80	80	35	11.3	1350	2.5	2200	15500	65	6.3	1550	1.8	2200	16000	59	
VF 150_100	100	31	9.0	1150	1.8	2200	15500	61	5.0	1300	1.3	2200	16000	55		

2600 Nm

	i	η_s %	n_2	M_{n2}	P_{n1}	R_{n1}	R_{n2}	η_d	n_2	M_{n2}	P_{n1}	R_{n1}	R_{n2}	η_d		
			min ⁻¹	Nm	kW	N	N	%	min ⁻¹	Nm	kW	N	N	%		
			$n_1 = 2800 \text{ min}^{-1}$							$n_1 = 1400 \text{ min}^{-1}$						
VFR 150	VFR 150_45	45	63	62	1350	10.6	1500	11600	84	31	1700	6.8	1500	14600	82	179
	VFR 150_60	60	58	47	1500	9.0	1500	13100	82	23.3	1900	5.9	1500	16000	79	
	VFR 150_69	69	56	41	1500	7.9	1500	14100	81	20.3	1850	5.1	1500	16000	77	
	VFR 150_90	90	47	31	1600	6.9	1500	15500	76	15.6	1950	4.4	1500	16000	72	
	VFR 150_120	120	43	23.3	1750	5.9	1500	15500	73	11.7	2000	3.6	1500	16000	68	
	VFR 150_138	138	44	20.3	1750	5.1	1500	15500	73	10.1	2000	3.1	1500	16000	68	
	VFR 150_168	168	41	16.7	1500	3.8	1500	15500	70	8.3	1750	2.4	1500	16000	65	
	VFR 150_192	192	38	14.6	1450	3.3	1500	15500	68	7.3	1700	2.1	1500	16000	62	
	VFR 150_240	240	34	11.7	1350	2.6	1500	15500	64	5.8	1550	1.6	1500	16000	58	
	VFR 150_300	300	30	9.3	1150	1.9	1500	15500	60	4.7	1300	1.2	1500	16000	54	
			$n_1 = 900 \text{ min}^{-1}$							$n_1 = 500 \text{ min}^{-1}$						
VFR 150	VFR 150_45	45	63	20.0	1950	5.2	1500	16000	79	11.1	2100	3.2	1500	16000	78	179
	VFR 150_60	60	58	15.0	2100	4.4	1500	16000	76	8.3	2300	2.7	1500	16000	74	
	VFR 150_69	69	56	13.0	2050	3.8	1500	16000	74	7.2	2200	2.3	1500	16000	72	
	VFR 150_90	90	47	10.0	2200	3.4	1500	16000	69	5.6	2400	2.1	1500	16000	66	
	VFR 150_120	120	43	7.5	2300	2.8	1500	16000	64	4.2	2600	1.8	1500	16000	62	
	VFR 150_138	138	44	6.5	2200	2.4	1500	16000	64	3.6	2400	1.5	1500	16000	62	
	VFR 150_168	168	41	5.4	1950	1.8	1500	16000	61	3.0	2100	1.1	1500	16000	59	
	VFR 150_192	192	38	4.7	1900	1.6	1500	16000	59	2.6	2000	1.0	1500	16000	56	
	VFR 150_240	240	34	3.8	1700	1.2	1500	16000	54	2.1	1800	0.76	1500	16000	52	
	VFR 150_300	300	30	3.0	1350	0.85	1500	16000	50	1.7	1450	0.54	1500	16000	47	



W/VF 86/150

2700 Nm



W/VF 86/150	i	η_s %	$n_1 = 1400 \text{ min}^{-1}$							$n_1 = 900 \text{ min}^{-1}$						180
			n_2 min ⁻¹	M_{n2} Nm	P_{n1} kW	R_{n1} N	R_{n2} N	η_d %	n_2 min ⁻¹	M_{n2} Nm	P_{n1} kW	R_{n1} N	R_{n2} N	η_d %		
			W/VF 86/150_200	200	29	7.0	2600	3.0	850	16000	64	4.5	2700	2.1	850	
W/VF 86/150_225	225	26	6.2	2600	2.7	850	16000	63	4.0	2700	1.9	850	16000	60		
W/VF 86/150_300	300	26	4.7	2600	2.2	850	16000	58	3.0	2700	1.5	850	16000	57		
W/VF 86/150_345	345	26	4.1	2600	1.9	850	16000	58	2.6	2700	1.3	850	16000	57		
W/VF 86/150_460	460	26	3.0	2600	1.5	850	16000	55	2.0	2700	1.0	850	16000	55		
W/VF 86/150_529	529	26	2.6	2600	1.3	850	16000	55	1.7	2700	0.93	850	16000	52		
W/VF 86/150_690	690	26	2.0	2600	1.1	850	16000	50	1.3	2700	0.78	850	16000	47		
W/VF 86/150_920	920	26	1.5	2600	0.92	850	16000	45	0.98	2700	0.64	850	16000	43		
W/VF 86/150_1380	1380	19	1.0	2600	0.66	850	16000	42	0.65	2700	0.46	850	16000	40		
W/VF 86/150_1840	1840	19	0.76	2600	0.55	850	16000	38	0.49	2700	0.38	850	16000	36		
W/VF 86/150_2944	2944	16	0.48	2600	0.48	850	16000	27	0.31	2700	0.35	850	16000	25		



VF 185 - VFR 185

3600 Nm

				n ₁ = 2800 min ⁻¹					n ₁ = 1400 min ⁻¹							
				n ₂	M _{n2}	P _{n1}	R _{n1}	R _{n2}	η _d	n ₂	M _{n2}	P _{n1}	R _{n1}		R _{n2}	η _d
				min ⁻¹	Nm	kW	N	N	%	min ⁻¹	Nm	kW	N		N	%
VF 185	VF 185_7	7	72	400	1313	60	2800	4670	91	200	1750	41	2800	5570	90	178
	VF 185_10	10	68	280	1365	44	2800	7390	90	140	1820	30	2800	8960	89	
	VF 185_15	15	66	187	1388	30	2800	9460	89	93	1850	21	2800	11600	88	
	VF 185_20	20	59	140	1703	28	2800	10500	88	70	2270	19.6	2800	12900	85	
	VF 185_30	30	54	93	1485	16.9	2800	13700	86	47	1980	11.8	2800	16900	83	
	VF 185_40	40	44	70	1973	17.6	—	14500	82	35	2630	12.4	—	17900	78	
	VF 185_50	50	41	56	1875	13.7	—	16300	80	28.0	2500	9.8	—	18000	76	
	VF 185_60	60	39	47	1703	10.7	2800	18000	78	23.3	2270	7.6	770	18000	74	
	VF 185_80	80	33	35	1590	7.8	2800	18000	75	17.5	2120	5.6	1140	18000	69	
	VF 185_100	100	30	28.0	1425	5.8	2800	18000	72	14.0	1900	4.3	2800	18000	65	
					n ₁ = 900 min ⁻¹					n ₁ = 500 min ⁻¹						
	VF 185_7	7	72	129	2000	30	2800	7120	89	71	2450	21	2800	8730	88	178
	VF 185_10	10	68	90	2150	23	2800	10200	88	50	2600	16.0	2800	12500	86	
	VF 185_15	15	66	60	2250	16.4	2800	13100	86	33	2800	11.8	2800	15700	84	
	VF 185_20	20	59	45	2750	15.6	2800	14600	84	25.0	3300	10.9	2800	17900	81	
	VF 185_30	30	54	30.0	2400	9.4	2800	19000	81	16.7	2800	6.5	2800	19500	77	
	VF 185_40	40	44	22.5	3100	9.7	—	19000	76	12.5	3600	6.8	—	19500	71	
	VF 185_50	50	41	18.0	2900	7.6	—	19000	73	10.0	3300	5.2	—	19500	68	
VF 185_60	60	39	15.0	2600	5.8	700	19000	71	8.3	3000	4.2	2800	19500	66		
VF 185_80	80	33	11.3	2400	4.3	1770	19000	66	6.3	2800	3.2	2800	19500	60		
VF 185_100	100	30	9.0	2000	3.0	2800	19000	62	5.0	2300	2.1	2800	19500	56		

4200 Nm

				n ₁ = 2800 min ⁻¹					n ₁ = 1400 min ⁻¹							
				n ₂	M _{n2}	P _{n1}	R _{n1}	R _{n2}	η _d	n ₂	M _{n2}	P _{n1}	R _{n1}		R _{n2}	η _d
				min ⁻¹	Nm	kW	N	N	%	min ⁻¹	Nm	kW	N		N	%
VFR 185	VFR 185_90	90	53	31	2400	9.9	1700	19000	80	15.6	2800	6.0	1700	19500	76	179
	VFR 185_120	120	43	23.3	3100	10.2	1700	19000	75	11.7	3600	6.3	1700	19500	70	
	VFR 185_150	150	40	18.7	2900	7.9	1700	19000	72	9.3	3300	4.8	1700	19500	67	
	VFR 185_180	180	38	15.6	2600	6.1	1700	19000	70	7.8	3000	3.8	1700	19500	65	
	VFR 185_240	240	32	11.7	2400	4.5	1700	19000	65	5.8	2800	2.9	1700	19500	59	
	VFR 185_300	300	29	9.3	2000	3.2	1700	19000	61	4.7	2300	2.0	1700	19500	55	
					n ₁ = 900 min ⁻¹					n ₁ = 500 min ⁻¹						
	VFR 185_90	90	53	10.0	3200	4.6	1700	19500	73	5.6	3500	2.9	1700	19500	71	179
	VFR 185_120	120	43	7.5	3800	4.5	1700	19500	66	4.2	4200	2.9	1700	19500	63	
	VFR 185_150	150	40	6.0	3400	3.4	1700	19500	63	3.3	3700	2.2	1700	19500	60	
	VFR 185_180	180	38	5.0	3300	2.9	1700	19500	60	2.8	3600	1.8	1700	19500	57	
	VFR 185_240	240	32	3.8	2800	2.0	1700	19500	54	2.1	2900	1.2	1700	19500	53	
	VFR 185_300	300	29	3.0	2400	1.5	1700	19500	50	1.7	2500	0.91	1700	19500	48	

(-) Contactar a nuestro servicio técnico, comunicando los datos relativos a la carga radial (sentido de giro, orientación y posición)



W/VF 86/185

4400 Nm



		<i>i</i>	η_s %	$n_1 = 1400 \text{ min}^{-1}$					$n_1 = 900 \text{ min}^{-1}$							
				n_2 min ⁻¹	M_{n2} Nm	P_{n1} kW	R_{n1} N	R_{n2} N	η_d %	n_2 min ⁻¹	M_{n2} Nm	P_{n1} kW	R_{n1} N		R_{n2} N	η_d %
				W/VF 86/185	W/VF 86/185_280	280	31	5.0	4200	4.2	850	19500	52		3.2	4400
W/VF 86/185_400	400	29	3.5	4200	3.2	850	19500	48	2.3	4400	2.3	850	19500	45		
W/VF 86/185_600	600	26	2.3	4200	2.3	850	19500	45	1.5	4400	1.6	850	19500	43		
W/VF 86/185_800	800	26	1.8	4200	1.8	850	19500	43	1.1	4400	1.3	850	19500	40		
W/VF 86/185_920	920	26	1.5	4200	1.6	850	19500	42	1.0	4400	1.2	850	19500	38		
W/VF 86/185_1200	1200	20	1.2	4200	1.5	850	19500	34	0.75	4400	0.99	850	19500	35		
W/VF 86/185_1600	1600	20	0.88	4200	1.1	850	19500	35	0.56	4400	0.79	850	19500	33		
W/VF 86/185_1840	1840	19	0.76	4200	0.98	850	19500	34	0.49	4400	0.70	850	19500	32		
W/VF 86/185_2560	2560	16	0.55	4200	0.83	850	19500	29	0.35	4400	0.60	850	19500	27		
W/VF 86/185_3200	3200	15	0.44	4200	0.80	850	19500	24	0.28	4400	0.59	850	19500	22		



VF 210 - VFR 210

5000 Nm

			n_2 min ⁻¹	M_{n2} Nm	P_{n1} kW	R_{n1} N	R_{n2} N	η_d %										
									$n_1 = 2800 \text{ min}^{-1}$				$n_1 = 1400 \text{ min}^{-1}$					
									i	η_s %								
VF 210	VF 210_7	7	71	400	1725	79	5300	14000	91	200	2300	54	5300	16700	90	178		
	VF 210_10	10	69	280	1988	65	5300	16300	90	140	2650	44	5300	19500	89			
	VF 210_15	15	63	187	2138	47	5300	19700	89	93	2850	32	5300	23700	88			
	VF 210_20	20	57	140	2325	39	4970	22000	87	70	3100	27	1100	26600	85			
	VF 210_30	30	51	93	2288	26	5300	25900	85	47	3050	18.5	1760	31500	83			
	VF 210_40	40	42	70	2625	23	—	28300	81	35	3500	17.0	—	31500	78			
	VF 210_50	50	39	56	2475	18.4	—	31000	79	28.0	3300	13.0	—	31500	76			
	VF 210_60	60	36	47	2363	15.0	—	31500	77	23.3	3015	10.0	—	31500	73			
	VF 210_80	80	31	35	2175	10.9	—	31500	73	17.5	2900	7.7	—	31500	69			
	VF 210_100	100	27	28	2025	8.5	950	31500	70	14.0	2700	6.0	—	31500	65			
				$n_1 = 900 \text{ min}^{-1}$					$n_1 = 500 \text{ min}^{-1}$									
VF 210	VF 210_7	7	71	129	2700	41	5300	18800	89	71	3400	29	5300	21800	88	178		
	VF 210_10	10	69	90	3150	34	5300	21900	88	50	3800	23	5300	26000	87			
	VF 210_15	15	63	60	3300	24	5300	27000	86	33	4100	17.2	5300	31800	84			
	VF 210_20	20	57	45	3800	22	—	29900	83	25.0	4700	15.4	—	34500	81			
	VF 210_30	30	51	30.0	3400	13.4	3750	33000	80	16.7	4000	9.3	5300	34500	77			
	VF 210_40	40	42	22.5	4300	13.5	—	33000	75	12.5	5000	9.4	—	34500	71			
	VF 210_50	50	39	18.0	4000	10.5	—	33000	72	10.0	4500	7.1	—	34500	68			
	VF 210_60	60	36	15.0	3720	8.5	—	33000	70	8.3	4300	6.0	—	34500	65			
	VF 210_80	80	31	11.3	3300	6.0	—	33000	65	6.3	3900	4.4	—	34500	60			
	VF 210_100	100	27	9.0	3000	4.6	—	33000	61	5.0	3400	3.4	1470	34500	56			

6300 Nm



			n_2 min ⁻¹	M_{n2} Nm	P_{n1} kW	R_{n1} N	R_{n2} N	η_d %										
									$n_1 = 2800 \text{ min}^{-1}$				$n_1 = 1400 \text{ min}^{-1}$					
									i	η_s %								
VFR 210	VFR 210_30	30	68	93	3150	36	1800	22100	87	47	3800	21.8	2200	27400	86	179		
	VFR 210_45	45	62	62	3300	25	1800	27000	85	31	4100	16.2	2200	33200	83			
	VFR 210_60	60	56	47	3800	22	1800	29900	82	23.0	4700	14.5	2200	34500	80			
	VFR 210_90	90	50	31	3400	14.1	1800	33000	79	15.6	4000	8.6	2200	34500	76			
	VFR 210_120	120	41	23.3	4300	14.3	1800	33000	74	11.7	5000	8.8	2200	34500	70			
	VFR 210_150	150	38	18.7	4000	11.1	1800	33000	71	9.3	4500	6.6	2200	34500	67			
	VFR 210_180	180	35	15.6	3720	8.8	1800	33000	69	7.8	4300	5.5	2200	34500	64			
	VFR 210_240	240	30	11.7	3300	6.3	1800	33000	64	5.8	3900	4.1	2200	34500	59			
	VFR 210_300	300	26	9.3	3000	4.9	1800	33000	60	4.7	3400	3.0	2200	34500	55			
					$n_1 = 900 \text{ min}^{-1}$					$n_1 = 500 \text{ min}^{-1}$								
VFR 210	VFR 210_30	30	68	30.0	4800	18.1	2300	30100	84	16.7	5500	11.8	2650	34500	82	179		
	VFR 210_45	45	62	20.0	4900	12.9	2300	34500	80	11.1	5600	8.4	2650	34500	78			
	VFR 210_60	60	56	15.0	5400	11.1	2300	34500	77	8.3	6000	7.1	2650	34500	74			
	VFR 210_90	90	50	10.0	4600	6.7	2300	34500	72	5.6	5150	4.3	2650	34500	70			
	VFR 210_120	120	41	7.5	5900	7.1	2300	34500	66	4.2	6300	4.4	2650	34500	63			
	VFR 210_150	150	38	6.0	5300	5.4	2300	34500	62	3.3	5900	3.5	2650	34500	59			
	VFR 210_180	180	35	5.0	4900	4.4	2300	34500	59	2.8	5400	2.8	2650	34500	56			
	VFR 210_240	240	30	3.8	4400	3.2	2300	34500	54	2.1	4800	2.1	2650	34500	50			
VFR 210_300	300	26	3.0	3600	2.3	2300	34500	49	1.7	4000	1.5	2650	34500	46				

(-) Contactar a nuestro servicio técnico, comunicando los datos relativos a la carga radial (sentido de giro, orientación y posición)



VF/VF 130/210

6500 Nm

		i	η_s %	$n_1 = 1400 \text{ min}^{-1}$					$n_1 = 900 \text{ min}^{-1}$							
				n_2 min ⁻¹	M_{n2} Nm	P_{n1} kW	R_{n1} N	R_{n2} N	η_d %	n_2 min ⁻¹	M_{n2} Nm	P_{n1} kW	R_{n1} N		R_{n2} N	η_d %
				VF/VF 130/210												
	VF/VF 130/210_280	280	30	5.0	6300	6.3	1500	34500	52	3.2	6500	4.4	1500	34500	50	180
	VF/VF 130/210_400	400	28	3.5	6300	4.6	1500	34500	50	2.3	6500	3.2	1500	34500	48	
	VF/VF 130/210_600	600	26	2.3	6300	3.6	1500	34500	43	1.5	6500	2.4	1500	34500	43	
	VF/VF 130/210_800	800	25	1.8	6300	2.8	1500	34500	41	1.1	6500	2.0	1500	34500	38	
	VF/VF 130/210_920	920	24	1.5	6300	2.7	1500	34500	37	1.0	6500	1.9	1500	34500	35	
	VF/VF 130/210_1200	1200	21	1.2	6300	2.2	—	34500	35	0.75	6500	1.5	—	34500	34	
	VF/VF 130/210_1600	1600	18	0.88	6300	1.8	—	34500	32	0.56	6500	1.2	—	34500	32	
	VF/VF 130/210_1840	1840	19	0.76	6300	1.7	—	34500	30	0.49	6500	1.2	490	34500	28	
	VF/VF 130/210_2560	2560	16	0.55	6300	1.5	1220	34500	24	0.35	6500	1.0	1500	34500	24	
	VF/VF 130/210_3200	3200	15	0.44	6300	1.3	1500	34500	22	0.28	6500	0.96	1500	34500	20	

(-) Contatar a nuestro servicio técnico, comunicando los datos relativos a la carga radial (sentido de giro, orientación y posición)



VF 250 - VFR 250

7100 Nm

				n ₁ = 2800 min ⁻¹					n ₁ = 1400 min ⁻¹							
				n ₂	M _{n2}	P _{n1}	R _{n1}	R _{n2}	η _d	n ₂	M _{n2}	P _{n1}	R _{n1}		R _{n2}	η _d
				min ⁻¹	Nm	kW	N	N	%	min ⁻¹	Nm	kW	N		N	%
VF 250	VF 250_7	7	71	400	2400	109	7000	18300	92	200	3200	75	7000	21900	91	178
	VF 250_10	10	69	280	2775	89	7000	21100	91	140	3700	61	7000	25300	90	
	VF 250_15	15	64	187	3000	65	7000	25100	90	93	4000	45	7000	30300	88	
	VF 250_20	20	59	140	3338	56	7000	28000	88	70	4450	38	7000	33900	86	
	VF 250_30	30	53	93	3000	34	7000	33400	86	47	4000	23	7000	40600	84	
	VF 250_40	40	41	70	3600	32	4680	36200	82	35	4800	22	—	44000	79	
	VF 250_50	50	36	56	3375	25	6370	39500	79	28.0	4500	17.0	—	47000	76	
	VF 250_60	60	38	47	3375	20.6	7000	42100	80	23.3	4500	15.0	—	47000	76	
	VF 250_80	80	32	35	2925	14.1	7000	47000	76	17.5	3900	10.0	—	47000	71	
	VF 250_100	100	29	28	2738	11.0	7000	47000	73	14.0	3650	7.8	3010	47000	68	
				n ₁ = 900 min ⁻¹					n ₁ = 500 min ⁻¹							
VF 250	VF 250_7	7	71	129	4150	63	7000	23700	90	71	5200	44	7000	27600	88	178
	VF 250_10	10	69	90	4800	51	7000	27600	89	50	6000	36	7000	32300	87	
	VF 250_15	15	64	60	5300	39	7000	33200	87	33	6400	27	7000	39500	85	
	VF 250_20	20	59	45	5950	33	1640	37200	85	25.0	7100	24	1910	44400	82	
	VF 250_30	30	53	30.0	5500	21	7000	44900	81	16.7	6000	14.7	7000	52000	79	
	VF 250_40	40	41	22.5	6500	20.0	—	48800	76	12.5	7000	13.6	—	52000	72	
	VF 250_50	50	36	18.0	6200	16.2	—	50000	73	10.0	6500	11.1	—	52000	68	
	VF 250_60	60	38	15.0	5600	12.2	—	50000	72	8.3	6300	8.6	4350	52000	68	
	VF 250_80	80	32	11.3	5200	9.3	—	50000	67	6.3	5400	6.8	7000	52000	62	
	VF 250_100	100	29	9.0	4800	7.2	3010	50000	63	5.0	5000	5.3	4160	52000	58	

9000 Nm



				n ₁ = 2800 min ⁻¹					n ₁ = 1400 min ⁻¹							
				n ₂	M _{n2}	P _{n1}	R _{n1}	R _{n2}	η _d	n ₂	M _{n2}	P _{n1}	R _{n1}		R _{n2}	η _d
				min ⁻¹	Nm	kW	N	N	%	min ⁻¹	Nm	kW	N		N	%
VFR 250	VFR 250_30	30	68	93	4800	54	2800	27800	89	47	6000	34	3500	34000	86	179
	VFR 250_45	45	63	62	5300	41	2800	33300	87	31	6400	25	3500	41300	84	
	VFR 250_60	60	58	47	5950	35	2800	37200	85	23.0	7100	21	3500	46100	81	
	VFR 250_90	90	52	31	5500	22	2800	44700	81	15.6	6000	12.6	3500	52000	78	
	VFR 250_120	120	40	23.3	6500	21.3	2800	48500	76	11.7	7000	12.1	3500	52000	71	
	VFR 250_150	150	35	18.7	6200	16.9	2800	50000	73	9.3	6500	9.5	3500	52000	67	
	VFR 250_180	180	37	15.6	5600	12.9	2800	50000	72	7.8	6300	7.7	3500	52000	67	
	VFR 250_240	240	31	11.7	5200	9.7	2800	50000	67	5.8	5400	5.4	3500	52000	61	
	VFR 250_300	300	28	9.3	4800	7.6	2800	50000	63	4.7	5000	4.3	3500	52000	57	
					n ₁ = 900 min ⁻¹					n ₁ = 500 min ⁻¹						
VFR 250	VFR 250_30	30	68	30.0	6500	24	3700	39600	84	16.7	7600	16.1	4200	47600	83	179
	VFR 250_45	45	63	20.0	6800	17.5	3700	48000	82	11.1	7900	11.6	3500	52000	80	
	VFR 250_60	60	58	15.0	7600	15.2	3700	52000	79	8.3	8600	9.9	3500	52000	76	
	VFR 250_90	90	52	10.0	6500	9.3	3700	52000	74	5.6	7400	6.1	3500	52000	71	
	VFR 250_120	120	40	7.5	7500	8.8	3700	52000	67	4.2	9000	6.2	3500	52000	64	
	VFR 250_150	150	35	6.0	7000	7.0	3700	52000	63	3.3	8600	5.1	3500	52000	59	
	VFR 250_180	180	37	5.0	6700	5.7	3700	52000	62	2.8	7600	3.8	3500	52000	59	
	VFR 250_240	240	31	3.8	5800	4.1	3700	52000	56	2.1	6500	2.7	3500	52000	52	
VFR 250_300	300	28	3.0	5300	3.2	3700	52000	52	1.7	6000	2.2	3500	52000	48		

(-) Contactar a nuestro servicio técnico, comunicando los datos relativos a la carga radial (sentido de giro, orientación y posición)



VF/VF 130/250

9200 Nm

		i	η _s %	n ₁ = 1400 min ⁻¹					n ₁ = 900 min ⁻¹							
				n ₂ min ⁻¹	M _{n2} Nm	P _{n1} kW	R _{n1} N	R _{n2} N	η _d %	n ₂ min ⁻¹	M _{n2} Nm	P _{n1} kW	R _{n1} N		R _{n2} N	η _d %
VF/VF 130/250	VF/VF 130/250_280	280	29	5.0	9000	8.9	1500	52000	53	3.2	9200	6.1	1500	52000	51	180
	VF/VF 130/250_400	400	27	3.5	9000	6.7	1500	52000	49	2.3	9200	4.6	1500	52000	47	
	VF/VF 130/250_600	600	26	2.3	9000	5.0	1500	52000	44	1.5	9200	3.4	1500	52000	43	
	VF/VF 130/250_800	800	24	1.8	9000	3.9	1500	52000	42	1.1	9200	2.7	1500	52000	40	
	VF/VF 130/250_920	920	23	1.5	9000	3.9	1500	52000	37	0.98	9200	2.7	1500	52000	35	
	VF/VF 130/250_1200	1200	20	1.2	9000	3.1	—	52000	35	0.75	9200	2.2	—	52000	33	
	VF/VF 130/250_1600	1600	18	0.88	9000	2.6	—	52000	32	0.56	9200	1.8	—	52000	30	
	VF/VF 130/250_1840	1840	18	0.76	9000	2.3	—	52000	31	0.49	9200	1.6	490	52000	29	
	VF/VF 130/250_2560	2560	16	0.55	9000	2.1	1500	52000	25	0.35	9200	1.5	1500	52000	23	
	VF/VF 130/250_3200	3200	14	0.44	9000	2.0	1500	52000	21	0.28	9200	1.4	1500	52000	19	

(-) Contatar a nuestro servicio técnico, comunicando los datos relativos a la carga radial (sentido de giro, orientación y posición)



23 COMBINACIONES DE LAS RELACIONES DE REDUCCIÓN DE LOS REDUCTORES COMBINADOS SERIE VF/VF, VF/W, W/VF

	Relación										i max	
VF/VF 30/44	245	350	420	560	700	840	1120	1680	2100			6000
VF 30	7	10	15	20	20	30	40	60	60			60
VF 44	35	35	28	28	35	28	28	28	35			100
VF/VF 30/49	240	315	420	540	720	900	1120	1440	2160	2700		6000
VF 30	10	7	15	15	20	20	40	40	60	60		60
VF 49	24	45	28	36	36	45	28	36	36	45		100
VF/W 30/63	240	315	450	570	720	900	1200	1520	2280	2700		7000
VF 30	10	7	15	15	30	30	40	40	60	60		70
W 63	24	45	30	38	24	30	30	38	38	45		100
VF/W 44/75	250	300	400	525	700	920	1200	1500	2100	2800		10000
VF 44	10	10	10	35	35	46	60	60	70	70		100
W 75	25	30	40	15	20	20	20	25	30	40		100
VF/W 44/86	230	300	400	525	700	920	1380	1840	2116	2760		10000
VF 44	10	10	10	35	35	46	46	46	46	60		100
W 86	23	30	40	15	20	20	30	40	46	46		100
VF/W 49/110	230	300	400	540	720	1080	1350	1656	2070	2800		10000
VF 49	10	10	10	18	36	36	45	36	45	70		100
W 110	23	30	40	30	20	30	30	46	46	40		100
W/VF 63/130	280	400	600	760	960	1200	1520	1800	2560	3200		10000
W 63	7	10	15	19	24	30	38	45	64	80		100
VF 130	40	40	40	40	40	40	40	40	40	40		100
W/VF 86/150	200	225	300	345	460	529	690	920	1380	1840	2944	10000
W 86	10	15	15	15	20	23	23	23	46	46	64	100
VF 150	20	15	20	23	23	23	30	40	30	40	46	100
W/VF 86/185	280	400	600	800	920	1200	1600	1840	2560	3200		10000
W 86	7	10	15	20	23	30	40	46	64	80		100
VF 185	40	40	40	40	40	40	40	40	40	40		100
VF/VF 130/210	280	400	600	800	920	1200	1600	1840	2560	3200		10000
VF 130	7	10	15	20	23	30	40	46	64	80		100
VF 210	40	40	40	40	40	40	40	40	40	40		100
VF/VF 130/250	280	400	600	800	920	1200	1600	1840	2560	3200		10000
VF 130	7	10	15	20	23	30	40	46	64	80		100
VF 250	40	40	40	40	40	40	40	40	40	40		100

Las combinaciones de relaciones de reducción indicadas en la tabla son las que se consideran preferentes y sugeridas por el fabricante.

El Servicio Técnico del Grupo Bonfiglioli podrá eventualmente considerar alguna solicitud de combinación de relaciones de reducción diferente a las propuestas, siempre y cuando sean inferiores al valor máximo indicado en la tabla.





24 PREDISPOSICIONES MOTOR

24.1 Motores estándar IEC

En la tabla se especifican los acoplamientos posibles en términos puramente geométricos.

La selección del motorreductor debe efectuarse siguiendo las instrucciones especificadas en el párrafo "Selección", respetando particularmente **la condición S f_s**.

 IEC	VF 27	VF 30	VF 44	VF 49	W 63	W 75	W 86	W 110	VF 130	VF 150	VF 185	VF 210	VF 250
P27 —	7...70	—	—	—	—	—	—	—	—	—	—	—	—
P56 $\frac{B5}{B14}$	—	7...70	—	—	—	—	—	—	—	—	—	—	—
P63 $\frac{B5}{B14}$	—	7...60	7...100	7...100	—	—	—	—	—	—	—	—	—
P71 $\frac{B5}{B14}$	—	—	7...35	7...60	7...100	$\frac{7...100}{—}$	$\frac{7...100}{—}$	—	—	—	—	—	—
P80 $\frac{B5}{B14}$	—	—	—	7...28	7...100	7...100	7...100	7...100	—	—	—	—	—
P90 $\frac{B5}{B14}$	—	—	—	—	7...30	7...100	7...100	7...100	$\frac{46...100}{—}$	—	—	—	—
P100 $\frac{B5}{B14}$	—	—	—	—	—	7...100	7...100	7...100	$\frac{7...80}{—}$	$\frac{23...100}{—}$	$\frac{50...100}{—}$	—	—
P112 $\frac{B5}{B14}$	—	—	—	—	—	7...100	7...100	7...100	$\frac{7...80}{—}$	$\frac{23...100}{—}$	$\frac{50...100}{—}$	—	—
P132 B5	—	—	—	—	—	—	—	7...100	7...40 #	7...46	30...80	7...100	7...100
P160 B5	—	—	—	—	—	—	—	—	—	7...20 #	15...40	7...100	7...100
P180 B5	—	—	—	—	—	—	—	—	—	—	7...20 #	7...100	7...100
P200 B5	—	—	—	—	—	—	—	—	—	—	—	7...100	7...100
P225 B5	—	—	—	—	—	—	—	—	—	—	—	7...100	7...100

 IEC	VFR 44	VFR 49	WR 63	WR 75	WR 86	WR 110	VFR 130	VFR 150	VFR 185	VFR 210	VFR 250
S44 —	70...500	—	—	—	—	—	—	—	—	—	—
P63 B5	—	30...300	21...300	21...300	21...300	—	—	—	—	—	—
P71 B5	—	—	21...300	21...300	21...300	21...300	—	—	—	—	—
P80 B5	—	—	—	21...300	21...300	21...300	30...300	—	—	—	—
P90 B5	—	—	—	15...150	15...150	21...300	30...300	$\frac{30...300}{\ominus(37.5;50)}$	$\frac{30...300}{\ominus(37.5;50)}$ $\frac{30...300}{\ominus(75;100)}$	—	—
P100 B5	—	—	—	—	—	21...300	30...300 #	$\frac{30...300}{\ominus(37.5;50)}$	$\frac{30...300}{\ominus(37.5;50)}$ $\frac{30...300}{\ominus(75;100)}$	30...300	30...300
P112 B5	—	—	—	—	—	21...300	30...300 #	$\frac{30...300}{\ominus(37.5;50)}$	$\frac{30...300}{\ominus(37.5;50)}$ $\frac{30...300}{\ominus(75;100)}$	30...300	30...300
P132 B5	—	—	—	—	—	—	—	$\frac{25...50 \#}{\ominus(30;45)}$	$\frac{25...100 \#}{\ominus(30;45)}$ $\frac{25...100 \#}{\ominus(60;90)}$	30...300	30...300
P160 B5	—	—	—	—	—	—	—	—	—	30...300 #	30...300 #

■ Relación del prerreductor helicoidal $i = 1.5$

Los acoplamientos motorreductores marcados con [#] se realizan con chaveta rebajada, suministrada con el propio reductor.



IEC		VF/VF 30/44	VF/VF 30/49	VF/W 30/63	VF/W 44/75	VF/W 44/86	VF/W 49/110	W/VF 63/130	W/VF 86/150	W/VF 86/185	VF/VF 130/210	VF/VF 130/250
P56	B5	—	—	240...2700	—	—	—	—	—	—	—	—
	B14	245...2100	240...2700	240...2700	—	—	—	—	—	—	—	—
P63	B5	—	—	240...2700	—	—	—	—	—	—	—	—
	B14	245...2100	240...2700	240...2700	250...2800	230...2760	230...2800	—	—	—	—	—
P71	B5	—	—	—	250...700	230...700	230...2400	280...3200	200...2944	280...3200	—	—
	B14	—	—	—	—	—	—	—	—	—	—	—
P80	B5	—	—	—	—	—	230...540	280...3200	200...2944	280...3200	—	—
	B14	—	—	—	—	—	—	—	—	—	—	—
P90	B5	—	—	—	—	—	—	280...1200	200...2944	280...3200	280...3200	280...3200
	B14	—	—	—	—	—	—	—	—	—	—	—
P100	B5	—	—	—	—	—	—	—	200...2944	280...3200	280...3200	280...3200
	B14	—	—	—	—	—	—	—	—	—	—	—
P112	B5	—	—	—	—	—	—	—	200...2944	280...3200	280...3200	280...3200
	B14	—	—	—	—	—	—	—	—	—	—	—
P132	B5	—	—	—	—	—	—	—	—	—	280...1600 #	280...1600 #

Los acoplamientos motorreductores marcados con [#] se realizan con chaveta rebajada, suministrada con el propio reductor.

24.2 Motores compactos

	M1	M2	M3
W 63	7 ... 100	7 ... 100	⊖
W 75	7 ... 100	7 ... 100	7 ... 100
W 86	7 ... 100	7 ... 100	7 ... 100
W 110	⊖	7 ... 100	7 ... 100

	M1	M2	M3
W/VF 63/130	280 ... 3200	280 ... 3200	⊖
W/VF 86/150	200 ... 2944	200 ... 2944	200 ... 2944
W/VF 86/185	280 ... 3200	280 ... 3200	280 ... 3200

24.3 Máxima potencia instalable en la entrada P_

		IEC_  (IM B5) (IM B14)											
		P63	P71	P80	P90	P100	P112	P132	P160	P180	P200	P225	
		BN											IEC
[kW]	2p	0.37	0.75	1.5	2.2	4	4	9.2	18.5	22	30	45	
	4p	0.25	0.55	1.1	1.85	3	4	9.2	15	22	30	47	
	6p	0.12	0.37	0.75	1.1	1.85	2.2	5.5	11	15	18.5	30	

24.4 Motores no normalizados

Para los motores eléctricos no normalizados, la unión del motor a los reductores de la serie VF y W puede configurarse con combinaciones de eje de entrada/brida híbridas, que no correspondan con la normativa IEC. La combinación eje/brida, está expresada mediante los respectivos diámetros como quedan representados seguidamente.

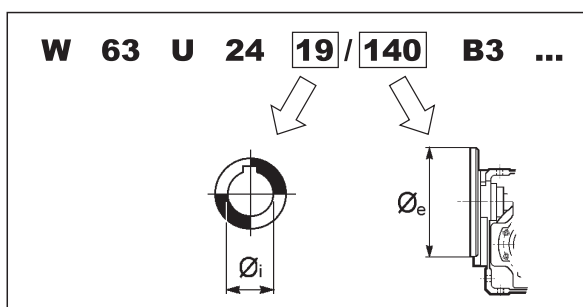



Los acoplamientos eje/brida disponibles y las relaciones de transmisión a los cuales están limitadas, están relacionadas en la tabla siguiente:

		80	90	105	120	140	160	200
VF 30	9		$7 \leq i \leq 70$	⊖		$7 \leq i \leq 70$	⊖	⊖
	11	$7 \leq i \leq 60$		⊖	$7 \leq i \leq 60$		⊖	⊖
VF 44	HS	⊖	$7 \leq i \leq 100$	$7 \leq i \leq 100$	⊖	$7 \leq i \leq 100$	$7 \leq i \leq 100$	⊖
	11	⊖		$7 \leq i \leq 100$	⊖		$7 \leq i \leq 100$	⊖
	14	⊖	$7 \leq i \leq 35$		⊖	$7 \leq i \leq 35$		⊖
VF 49	HS	⊖	$7 \leq i \leq 100$	$7 \leq i \leq 100$	$7 \leq i \leq 100$	$7 \leq i \leq 100$	$7 \leq i \leq 100$	$7 \leq i \leq 100$
	11	⊖		$7 \leq i \leq 100$	$7 \leq i \leq 100$		$7 \leq i \leq 100$	$7 \leq i \leq 100$
	14	⊖	$7 \leq i \leq 60$		$7 \leq i \leq 60$	$7 \leq i \leq 60$		$7 \leq i \leq 60$
	19	⊖	$7 \leq i \leq 28$	$7 \leq i \leq 28$		$7 \leq i \leq 28$	$7 \leq i \leq 28$	
W 63	19	⊖	⊖	⊖	⊖	$7 \leq i \leq 100$	⊖	
W 75	14	⊖	⊖	⊖	⊖	⊖		$7 \leq i \leq 100$
	19	⊖	⊖	⊖		$7 \leq i \leq 100$	$7 \leq i \leq 100$	
	24	⊖	⊖	⊖	$7 \leq i \leq 100$		$7 \leq i \leq 100$	
W 86	14	⊖	⊖	⊖	⊖	⊖		$7 \leq i \leq 100$
	19	⊖	⊖	⊖		$7 \leq i \leq 100$	$7 \leq i \leq 100$	
	24	⊖	⊖	⊖	$7 \leq i \leq 100$		$7 \leq i \leq 100$	
W 110	19	⊖	⊖	⊖		$7 \leq i \leq 100$	⊖	⊖
	24	⊖	⊖	⊖	$7 \leq i \leq 100$		⊖	⊖

Acoplamiento estándar

Algunos acoplamientos híbridos eje/brida pueden realizarse en los reductores VF con entre-ejes de 130 mm y superiores. En estos casos se deberá consultar su disponibilidad con el Servicio Técnico de Bonfiglioli.

Las configuraciones resultantes de la tabla arriba indicada deben entenderse como posibles solamente en los términos que conciernen a su compatibilidad geométrica.

La compatibilidad mecánica del correspondiente motor/reductor deberá verificarse su posibilidad en las tablas de selección potencia/velocidad.

Particularmente deben evitarse el acoplamiento de motores con un coeficiente de seguridad $S < 0,9$.



25 MOMENTO DE INERCIA

En la tabla técnica siguiente, están indicados los valores del momento de inercia J , Kgm^2 , referidos al eje de entrada del reductor; para una mayor facilidad de lectura, incluimos el significado de los símbolos usados.



Los valores referidos a este símbolo corresponden al reductor compacto sin motor. En este caso para obtener el momento de inercia del motorreductor, se deberá sumar al valor correspondiente al reductor compacto, el del motor que se aplique (dato que se encuentra en las tablas de características técnicas de los motores eléctricos).

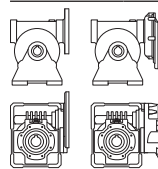

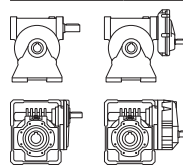

El valor relativo a este símbolo corresponde al reductor predispuesto para el montaje de motor (tamaño IEC).





El valor atribuido al reductor es referido a este símbolo.

VF 27



		i	J ($\cdot 10^{-4}$) [kgm^2]				
			P27				
							HS
VF 27	VF 27_7	7	0.02	—	—	—	0.02
	VF 27_10	10	0.01	—	—	—	0.01
	VF 27_15	15	0.01	—	—	—	0.01
	VF 27_20	20	0.01	—	—	—	0.01
	VF 27_30	30	0.01	—	—	—	0.01
	VF 27_40	40	0.01	—	—	—	0.01
	VF 27_60	60	0.01	—	—	—	0.01
	VF 27_70	70	0.01	—	—	—	0.01

VF 30

		i	J ($\cdot 10^{-4}$) [kgm^2]				
			P56	P63			
							HS
VF 30	VF 30_7	7	0.08	0.07	—	—	0.04
	VF 30_10	10	0.07	0.06	—	—	0.03
	VF 30_15	15	0.07	0.06	—	—	0.03
	VF 30_20	20	0.06	0.06	—	—	0.03
	VF 30_30	30	0.06	0.06	—	—	0.03
	VF 30_40	40	0.06	0.06	—	—	0.03
	VF 30_60	60	0.06	0.05	—	—	0.02
	VF 30_70	70	0.06	—	—	—	0.02





VF 44 - VFR 44

		i	J ($\cdot 10^{-4}$) [kgm ²]					
			 S44	P63	P71	 HS		
VF 44	VF 44_7	7	—	0.29	0.27	—	—	0.18
	VF 44_10	10	—	0.24	0.22	—	—	0.14
	VF 44_14	14	—	0.23	0.21	—	—	0.12
	VF 44_20	20	—	0.19	0.18	—	—	0.09
	VF 44_28	28	—	0.21	0.19	—	—	0.11
	VF 44_35	35	—	0.19	0.18	—	—	0.09
	VF 44_46	46	—	0.18	—	—	—	0.08
	VF 44_60	60	—	0.17	—	—	—	0.07
	VF 44_70	70	—	0.17	—	—	—	0.07
	VF 44_100	100	—	0.17	—	—	—	0.07
VFR 44	VFR 44_70	70	0.21	—	—	—	—	—
	VFR 44_100	100	0.20	—	—	—	—	—
	VFR 44_140	140	0.20	—	—	—	—	—
	VFR 44_175	175	0.20	—	—	—	—	—
	VFR 44_230	230	0.20	—	—	—	—	—
	VFR 44_300	300	0.20	—	—	—	—	—
	VFR 44_350	350	0.20	—	—	—	—	—
	VFR 44_500	500	0.20	—	—	—	—	—



VF 49 - VFR 49

		i	J ($\cdot 10^{-4}$) [kgm ²]					
			P63	P71	 P80	 	 HS	
VF 49	VF 49_7	7	0.69	0.67	0.61	—	—	0.42
	VF 49_10	10	0.61	0.60	0.53	—	—	0.34
	VF 49_14	14	0.58	0.57	0.5	—	—	0.31
	VF 49_18	18	0.54	0.53	0.46	—	—	0.27
	VF 49_24	24	0.52	0.5	0.44	—	—	0.24
	VF 49_28	28	0.56	0.54	0.48	—	—	0.28
	VF 49_36	36	0.53	0.51	—	—	—	0.25
	VF 49_45	45	0.51	0.49	—	—	—	0.24
	VF 49_60	60	0.50	0.48	—	—	—	0.23
	VF 49_70	70	0.50	—	—	—	—	0.22
	VF 49_80	80	0.49	—	—	—	—	0.22
VF 49_100	100	0.49	—	—	—	—	0.22	
VFR 49	VFR 49_30	30	0.74	—	—	—	—	0.94
	VFR 49_42	42	0.73	—	—	—	—	0.93
	VFR 49_54	54	0.73	—	—	—	—	0.93
	VFR 49_72	72	0.73	—	—	—	—	0.93
	VFR 49_84	84	0.73	—	—	—	—	0.93
	VFR 49_108	108	0.73	—	—	—	—	0.93
	VFR 49_135	135	0.73	—	—	—	—	0.93
	VFR 49_180	180	0.73	—	—	—	—	0.93
	VFR 49_210	210	0.72	—	—	—	—	0.92
	VFR 49_240	240	0.72	—	—	—	—	0.92
	VFR 49_300	300	0.72	—	—	—	—	0.92

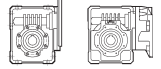
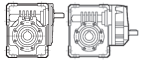

W 63 - WR 63

		i	J ($\cdot 10^{-4}$) [kgm ²]									
												
			S1	S2	S3	P63	P71	P80	P90			HS
W 63	W 63_7	7	3.4	3.6	—	—	3.5	3.5	3.5	—	—	3.6
	W 63_10	10	3.1	3.3	—	—	3.2	3.3	3.2	—	—	3.3
	W 63_12	12	3.1	3.3	—	—	3.1	3.2	3.1	—	—	3.3
	W 63_15	15	3.0	3.2	—	—	3.0	3.1	3.0	—	—	3.2
	W 63_19	19	2.9	3.1	—	—	2.9	3.0	2.9	—	—	3.1
	W 63_24	24	2.8	3.1	—	—	2.9	3.0	2.9	—	—	3.0
	W 63_30	30	2.9	3.1	—	—	2.9	3.0	2.9	—	—	3.1
	W 63_38	38	2.8	3.1	—	—	2.9	3.0	2.9	—	—	3.0
	W 63_45	45	2.8	3.0	—	—	2.9	2.9	2.9	—	—	3.0
	W 63_64	64	2.8	3.0	—	—	2.8	2.9	2.8	—	—	3.0
	W 63_80	80	2.8	3.0	—	—	2.8	2.9	2.8	—	—	3.0
W 63_100	100	2.8	3.0	—	—	2.8	2.9	2.8	—	—	2.9	
WR 63	WR 63_21	21	—	—	—	0.84	0.83	—	—	—	—	0.81
	WR 63_30	30	—	—	—	0.81	0.80	—	—	—	—	0.78
	WR 63_36	36	—	—	—	0.81	0.80	—	—	—	—	0.77
	WR 63_45	45	—	—	—	0.80	0.79	—	—	—	—	0.76
	WR 63_57	57	—	—	—	0.79	0.78	—	—	—	—	0.75
	WR 63_72	72	—	—	—	0.78	0.77	—	—	—	—	0.74
	WR 63_90	90	—	—	—	0.79	0.78	—	—	—	—	0.75
	WR 63_114	114	—	—	—	0.78	0.77	—	—	—	—	0.74
	WR 63_135	135	—	—	—	0.78	0.77	—	—	—	—	0.74
	WR 63_192	192	—	—	—	0.77	0.76	—	—	—	—	0.74
	WR 63_240	240	—	—	—	0.77	0.76	—	—	—	—	0.74
WR 63_300	300	—	—	—	0.77	0.76	—	—	—	—	0.73	



W 75 - WR 75

		i	J ($\cdot 10^{-4}$) [kgm ²]									
			 S1 S2 S3			 P63 P71 P80 P90 P100 P112						 HS
W 75	W 75_7	7	6.9	6.6	6.6	—	6.9	7.0	6.9	6.9	6.9	7.3
	W 75_10	10	6.4	6.1	6.1	—	6.4	6.4	6.3	5.7	5.7	6.8
	W 75_15	15	6.1	5.8	5.8	—	6.1	6.1	6.0	5.3	5.3	6.5
	W 75_20	20	5.9	5.6	5.6	—	5.9	5.9	5.9	5.2	5.2	6.3
	W 75_25	25	5.9	5.6	5.6	—	6.0	6.0	5.9	5.2	5.2	6.3
	W 75_30	30	5.9	5.6	5.6	—	5.9	5.9	5.9	5.2	5.2	6.3
	W 75_40	40	5.9	5.6	5.6	—	5.9	5.9	5.8	5.2	5.2	6.3
	W 75_50	50	5.9	5.6	5.6	—	5.9	5.9	5.8	5.1	5.1	6.2
	W 75_60	60	5.8	5.5	5.5	—	5.8	5.9	5.8	5.1	5.1	6.2
	W 75_80	80	5.8	5.5	5.5	—	5.8	5.8	5.8	5.1	5.1	6.2
W 75_100	100	5.8	5.5	5.5	—	5.8	5.8	5.7	5.0	5.0	6.2	





WR 75	WR 75_21	21	—	—	—	1.2	1.2	2.1	—	—	—	1.9
	WR 75_30	30	—	—	—	1.1	1.1	2.1	—	—	—	1.1
	WR 75_45	45	—	—	—	1.1	1.1	2.0	—	—	—	1.1
	WR 75_60	60	—	—	—	1.1	1.1	2.0	—	—	—	1.0
	WR 75_75	75	—	—	—	1.1	1.1	2.0	—	—	—	1.0
	WR 75_90	90	—	—	—	1.1	1.1	2.0	—	—	—	1.0
	WR 75_120	120	—	—	—	1.1	1.1	2.0	—	—	—	1.0
	WR 75_150	150	—	—	—	1.1	1.1	2.0	—	—	—	1.0
	WR 75_180	180	—	—	—	1.1	1.1	2.0	—	—	—	1.0
	WR 75_240	240	—	—	—	1.1	1.1	2.0	—	—	—	1.0
	WR 75_300	300	—	—	—	1.1	1.1	2.0	—	—	—	1.0

		J ($\cdot 10^{-4}$) [kgm ²]
	i	 P90

WR 75_P90 B5	WR 75_15	15	6.0
	WR 75_22.5	22.5	5.9
	WR 75_30	30	5.8
	WR 75_37.5	37.5	5.8
	WR 75_45	45	5.8
	WR 75_60	60	5.8
	WR 75_75	75	5.8
	WR 75_90	90	5.7
	WR 75_120	120	5.7
	WR 75_150	150	5.7

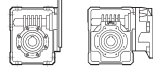

W 86 - WR 86

		i	J ($\cdot 10^{-4}$) [kgm ²]									
			 S1 S2 S3			  P63 P71 P80 P90 P100					  HS	
W 86	W 86_7	7	9.7	9.4	9.4	—	9.7	9.7	9.6	9.6	—	10.1
	W 86_10	10	8.4	8.1	8.1	—	8.4	8.4	8.3	7.7	—	8.9
	W 86_15	15	7.7	7.4	7.4	—	7.7	7.7	7.7	7.0	—	8.2
	W 86_20	20	6.9	6.6	6.6	—	6.9	7.0	6.9	6.2	—	7.4
	W 86_23	23	6.8	6.5	6.5	—	6.8	6.9	6.8	6.1	—	7.3
	W 86_30	30	7.3	7.0	7.0	—	7.3	7.3	7.3	6.6	—	7.8
	W 86_40	40	6.7	6.4	6.4	—	6.7	6.7	6.6	6.0	—	7.2
	W 86_46	46	6.7	6.4	6.4	—	6.7	6.7	6.6	5.9	—	7.1
	W 86_56	56	6.6	6.3	6.3	—	6.6	6.7	6.6	5.9	—	7.1
	W 86_64	64	6.6	6.3	6.3	—	6.6	6.6	6.5	5.9	—	7.1
	W 86_80	80	6.6	6.3	6.3	—	6.6	6.6	6.5	5.9	—	7.1
	W 86_100	100	6.4	6.1	6.1	—	6.4	6.5	6.4	5.7	—	6.9

WR 86	WR 86_21	21	—	—	—	1.5	1.5	2.4	—	—	—	2.2
	WR 86_30	30	—	—	—	1.4	1.3	2.3	—	—	—	1.3
	WR 86_45	45	—	—	—	1.3	1.3	2.2	—	—	—	1.2
	WR 86_60	60	—	—	—	1.2	1.2	2.1	—	—	—	1.2
	WR 86_69	69	—	—	—	1.2	1.2	2.1	—	—	—	1.1
	WR 86_90	90	—	—	—	1.2	1.2	2.2	—	—	—	1.2
	WR 86_120	120	—	—	—	1.2	1.2	2.1	—	—	—	1.1
	WR 86_138	138	—	—	—	1.2	1.2	2.1	—	—	—	1.1
	WR 86_168	168	—	—	—	1.2	1.2	2.1	—	—	—	1.1
	WR 86_192	192	—	—	—	1.2	1.1	2.1	—	—	—	1.1
	WR 86_240	240	—	—	—	1.2	1.1	2.1	—	—	—	1.1
	WR 86_300	300	—	—	—	1.1	1.1	2.1	—	—	—	1.1

		J ($\cdot 10^{-4}$) [kgm ²]	
		i	 P90

WR 86_P90 B5	WR 86_15	15	6.9
	WR 86_22.5	22.5	6.6
	WR 86_30	30	6.3
	WR 86_34.5	34.5	6.2
	WR 86_45	45	6.4
	WR 86_60	60	6.2
	WR 86_69	69	6.1
	WR 86_84	84	6.1
	WR 86_96	96	6.0
	WR 86_120	120	6.0
	WR 86_150	150	5.9



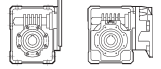
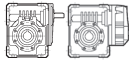

W 110 - WR 110

		i	J ($\cdot 10^{-4}$) [kgm ²]									
												
			S1	S2	S3	P63	P71	P80	P90	P100	P132	HS
W 110	W 110_7	7	—	22	22	—	—	23	23	23	28	23
	W 110_10	10	—	19	19	—	—	19	19	24	24	20
	W 110_15	15	—	17	17	—	—	17	17	22	22	17
	W 110_20	20	—	14	14	—	—	14	14	19	19	15
	W 110_23	23	—	14	14	—	—	14	14	19	19	15
	W 110_30	30	—	15	15	—	—	16	16	20	20	16
	W 110_40	40	—	13	13	—	—	14	14	19	19	14
	W 110_46	46	—	13	13	—	—	13	13	18	18	14
	W 110_56	56	—	13	13	—	—	13	13	18	18	14
	W 110_64	64	—	13	13	—	—	13	13	18	18	14
	W 110_80	80	—	13	13	—	—	13	13	18	18	14
W 110_100	100	—	13	13	—	—	13	13	18	18	14	
WR 110	WR 110_21	21	—	—	—	—	3.0	9.0	8.8	8.9	—	9.2
	WR 110_30	30	—	—	—	—	2.5	8.6	8.4	8.4	—	8.8
	WR 110_45	45	—	—	—	—	2.3	8.3	8.2	8.2	—	8.5
	WR 110_60	60	—	—	—	—	2.0	8.1	7.9	7.9	—	8.3
	WR 110_69	69	—	—	—	—	2.0	8.0	7.9	7.9	—	8.2
	WR 110_90	90	—	—	—	—	2.2	8.2	8.1	8.1	—	8.4
	WR 110_120	120	—	—	—	—	1.9	8.0	7.8	7.9	—	8.2
	WR 110_138	138	—	—	—	—	1.9	8.0	7.8	7.8	—	8.2
	WR 110_168	168	—	—	—	—	1.9	8.0	7.8	7.8	—	8.1
	WR 110_192	192	—	—	—	—	1.9	7.9	7.8	7.8	—	8.1
	WR 110_240	240	—	—	—	—	1.9	7.9	7.8	7.8	—	8.1
WR 110_300	300	—	—	—	—	1.9	7.9	7.8	7.8	—	8.1	





VF 130 - VFR 130

		i	J ($\cdot 10^{-4}$) [kgm ²]					HS
			P80	P90	  P100	P112	P132	
VF 130	VF 130_7	7	—	—	36	36	35	31
	VF 130_10	10	—	—	27	27	25	22
	VF 130_15	15	—	—	20	20	18	15
	VF 130_20	20	—	—	17	17	15	11
	VF 130_23	23	—	—	16	16	14	11
	VF 130_30	30	—	—	17	17	15	12
	VF 130_40	40	—	—	15	15	14	9.9
	VF 130_46	46	—	14	14	14	—	8.2
	VF 130_56	56	—	13	13	13	—	7.8
	VF 130_64	64	—	13	13	13	—	7.4
	VF 130_80	80	—	13	12	12	—	7.0
	VF 130_100	100	—	13	—	—	—	8.9
VFR 130	VFR 130_30	30	5.3	5.3	5.2	5.2	—	5.7
	VFR 130_45	45	4.5	4.5	4.4	4.4	—	4.9
	VFR 130_60	60	4.2	4.1	4.1	4.1	—	4.6
	VFR 130_69	69	4.1	4.0	4.0	4.0	—	4.5
	VFR 130_90	90	4.2	4.1	4.1	4.1	—	4.6
	VFR 130_120	120	4.0	3.9	4.0	4.0	—	4.4
	VFR 130_138	138	3.8	3.8	3.7	3.7	—	4.2
	VFR 130_168	168	3.8	3.7	3.7	3.7	—	4.1
	VFR 130_192	192	3.7	3.7	3.6	3.6	—	4.1
	VFR 130_240	240	3.7	3.6	3.6	3.6	—	4.1
	VFR 130_300	300	3.9	3.8	3.8	3.8	—	4.3



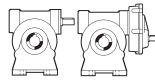

VF 150 - VFR 150

		i	J ($\cdot 10^{-4}$) [kgm ²]				
			P90	 P100	 P112	P132	 HS
VF 150	VF 150_7	7	—	—	—	58	50
	VF 150_10	10	—	—	—	44	35
	VF 150_15	15	—	—	—	29	21
	VF 150_20	20	—	—	—	27	19
	VF 150_23	23	—	28	28	26	17
	VF 150_30	30	—	31	31	29	21
	VF 150_40	40	—	26	26	24	16
	VF 150_46	46	—	24	24	22	13
	VF 150_56	56	25	24	24	—	13
	VF 150_64	64	24	23	23	—	12
	VF 150_80	80	23	22	22	—	11
	VF 150_100	100	23	22	22	—	11
VFR 150	VFR 150_25	25	—	—	—	15	—
	VFR 150_30	30	10	10	10	—	11
	VFR 150_37.5	37.5	—	—	—	13	—
	VFR 150_45	45	8.8	8.8	8.8	—	9.7
	VFR 150_50	50	—	—	—	12	—
	VFR 150_60	60	8.3	8.3	8.3	—	9.2
	VFR 150_69	69	8.4	8.4	8.4	—	9.3
	VFR 150_90	90	8.7	8.7	8.7	—	9.7
	VFR 150_120	120	8.2	8.2	8.2	—	9.2
	VFR 150_138	138	7.9	7.9	7.9	—	8.9
	VFR 150_168	168	7.9	7.9	7.9	—	8.9
	VFR 150_192	192	7.8	7.8	7.8	—	8.8
	VFR 150_240	240	7.7	7.7	7.7	—	8.6
VFR 150_300	300	7.7	7.7	7.7	—	8.6	



VF 185 - VFR 185

		i	J ($\cdot 10^{-4}$) [kgm ²]						HS
			P90	P100	 P112	 P132	P160	P180	
VF 185	VF 185_7	7	—	—	—	—	—	146	128
	VF 185_10	10	—	—	—	—	—	108	91
	VF 185_15	15	—	—	—	—	70	88	50
	VF 185_20	20	—	—	—	—	69	66	48
	VF 185_30	30	—	—	—	58	54	—	34
	VF 185_40	40	—	—	—	63	61	—	41
	VF 185_50	50	—	59	59	58	—	—	35
	VF 185_60	60	—	55	55	53	—	—	31
	VF 185_80	80	—	52	52	51	—	—	28
	VF 185_100	100	—	51	51	—	—	—	27
VFR 185	VFR 185_25	25	—	—	—	24	—	—	—
	VFR 185_30	30	17	17	17	—	—	—	18
	VFR 185_37.5	37.5	—	—	—	17	—	—	—
	VFR 185_45	45	12	12	12	—	—	—	13
	VFR 185_50	50	—	—	—	17	—	—	—
	VFR 185_60	60	12	12	12	—	—	—	13
	VFR 185_75	75	—	—	—	15	—	—	—
	VFR 185_90	90	10	10	10	—	—	—	11
	VFR 185_100	100	—	—	—	16	—	—	—
	VFR 185_120	120	11	11	11	—	—	—	12
	VFR 185_150	150	10	10	10	—	—	—	11
	VFR 185_180	180	9.9	9.9	9.9	—	—	—	11
	VFR 185_240	240	9.6	9.6	9.6	—	—	—	11
VFR 185_300	300	9.5	9.4	9.4	—	—	—	10	



VF 210 - VFR 210

		i	J ($\cdot 10^{-4}$) [kgm ²]							HS
			P100	P112	P132	P160	P180	P200	P225	
VF 210	VF 210_7	7	—	—	286	286	286	286	286	286
	VF 210_10	10	—	—	177	177	177	177	177	177
	VF 210_15	15	—	—	120	120	120	120	120	120
	VF 210_20	20	—	—	116	116	116	116	116	116
	VF 210_30	30	—	—	81	81	81	81	81	81
	VF 210_40	40	—	—	98	98	98	98	98	98
	VF 210_50	50	—	—	84	84	84	84	84	84
	VF 210_60	60	—	—	75	75	75	75	75	75
	VF 210_80	80	—	—	68	68	68	68	68	68
	VF 210_100	100	—	—	63	63	63	63	63	63
VFR 210	VFR 210_30	30	48	48	47	47	—	—	—	51
	VFR 210_45	45	41	41	41	41	—	—	—	45
	VFR 210_60	60	41	41	41	40	—	—	—	45
	VFR 210_90	90	37	37	37	36	—	—	—	41
	VFR 210_120	120	39	39	39	38	—	—	—	43
	VFR 210_150	150	37	37	37	37	—	—	—	41
	VFR 210_180	180	36	36	36	36	—	—	—	40
	VFR 210_240	240	36	36	36	35	—	—	—	39
	VFR 210_300	300	35	35	35	34	—	—	—	39



VF 250 - VFR 250



		i	J ($\cdot 10^{-4}$) [kgm ²]							HS
			P100	P112	P132	P160	P180	P200	P225	
VF 250	VF 250_7	7	—	—	620	620	620	620	620	620
	VF 250_10	10	—	—	387	387	387	387	387	387
	VF 250_15	15	—	—	266	266	266	266	266	266
	VF 250_20	20	—	—	242	242	242	242	242	242
	VF 250_30	30	—	—	184	184	184	184	184	184
	VF 250_40	40	—	—	241	241	241	241	241	241
	VF 250_50	50	—	—	240	240	240	240	240	240
	VF 250_60	60	—	—	158	158	158	158	158	158
	VF 250_80	80	—	—	160	160	160	160	160	160
	VF 250_100	100	—	—	149	149	149	149	149	149
VFR 250	VFR 250_30	30	71	71	71	70	—	—	—	75
	VFR 250_45	45	58	58	57	57	—	—	—	61
	VFR 250_60	60	55	55	55	54	—	—	—	58
	VFR 250_90	90	48	48	48	48	—	—	—	52
	VFR 250_120	120	55	55	54	54	—	—	—	58
	VFR 250_150	150	55	55	54	54	—	—	—	58
	VFR 250_180	180	46	46	45	45	—	—	—	49
	VFR 250_240	240	46	46	45	45	—	—	—	49
	VFR 250_300	300	45	45	44	44	—	—	—	48

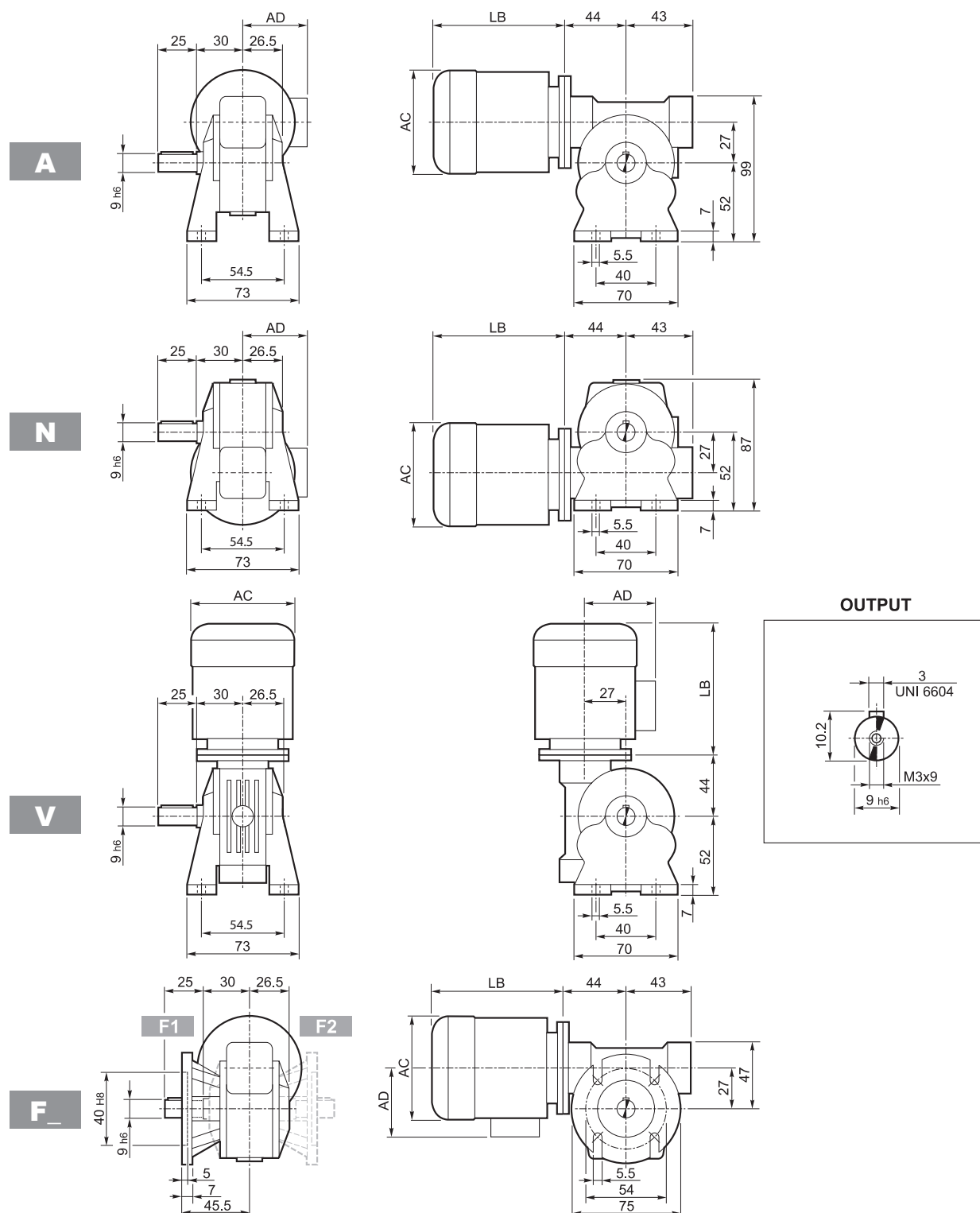

26 DIMENSIONES MOTORREDUCTORES Y REDUCTORES PREDISPUESOTOS PARA MOTOR IEC

VF 27...BN27



	P_n kW	n min ⁻¹	M_n Nm	η %	$\cos\phi$	I_n A (400V)	I_s In	M_s Mn	M_a Mn	J_m ($\cdot 10^{-4}$) kgm ²		LB	AC	AD
BN 27A 4	0.04	1405	0.27	38.4	0.6	0.25	2.9	3.6	3.1	1.49	3.3	168	112	92
BN 27B 4	0.06	1340	0.43	46.8	0.65	0.28	2.6	2.3	2.0	1.49	3.3	168	112	92
BN 27C 4	0.09	1380	0.63	46	0.65	0.43	2.8	2.3	1.9	1.49	3.3	168	112	92



VF 30...P (IEC)

A

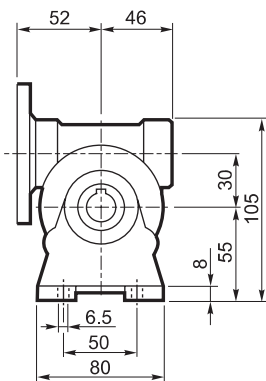
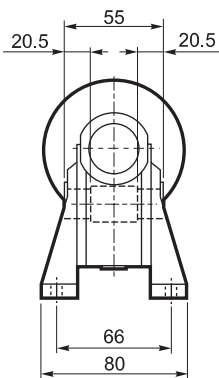

N

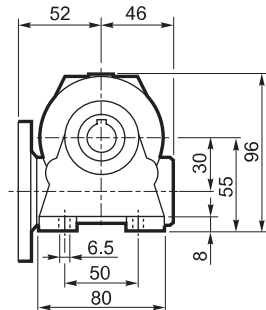
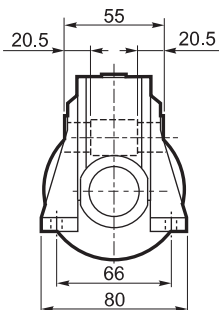

V

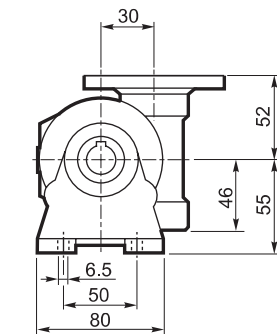
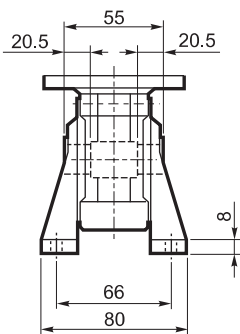

P

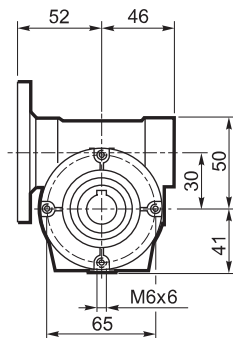
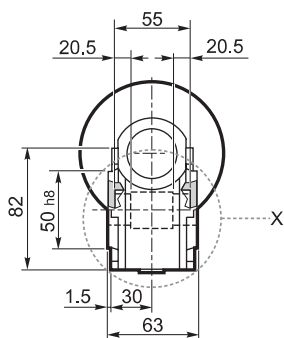

INPUT

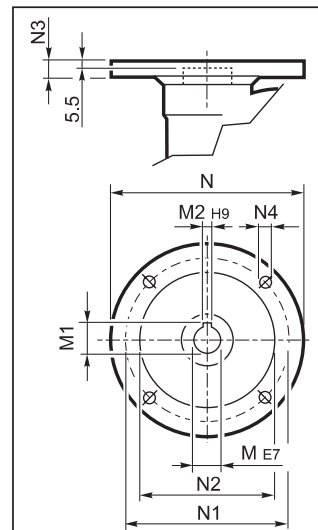

P56 B14

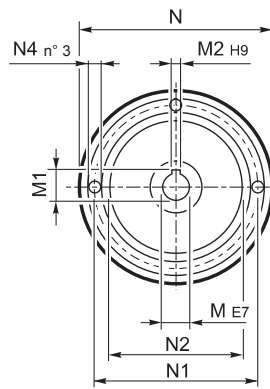

OUTPUT

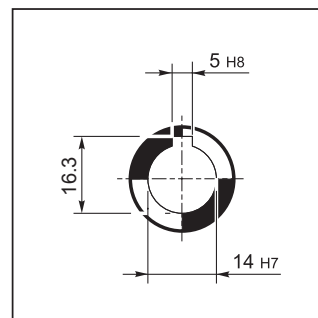

X

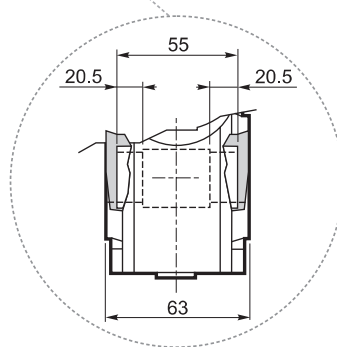



VF 30...P (IEC)

F

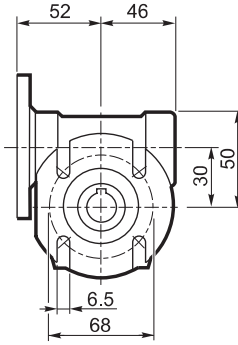
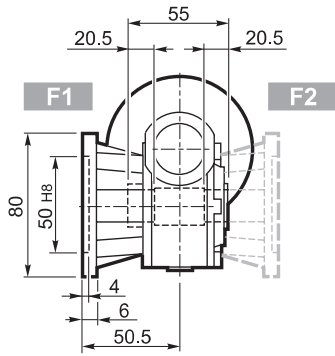

U

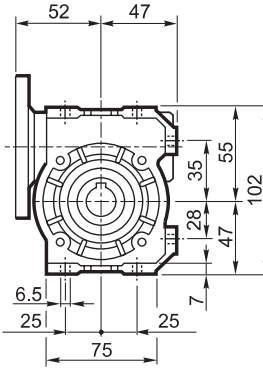
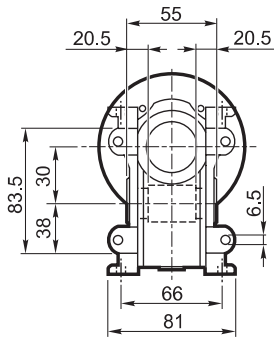

INPUT

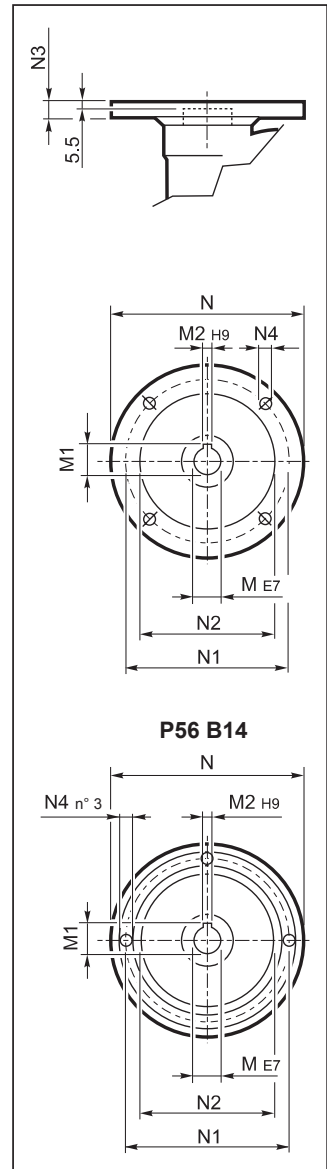

OUTPUT

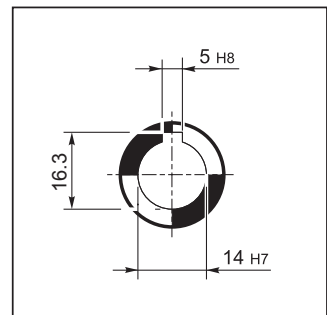

		M	M1	M2	N	N1	N2	N3	N4	
VF 30	P56 B5	9	10.4	3	120	100	80	7	7	1.1
VF 30	P56 B14	9	10.4	3	80	65	50	7	5.5	
VF 30	P63 B5	11	12.8	4	140	115	95	8	9.5	
VF 30	P63 B14	11	12.8	4	90	75	60	6	5.5	



VF 44...P (IEC)

A

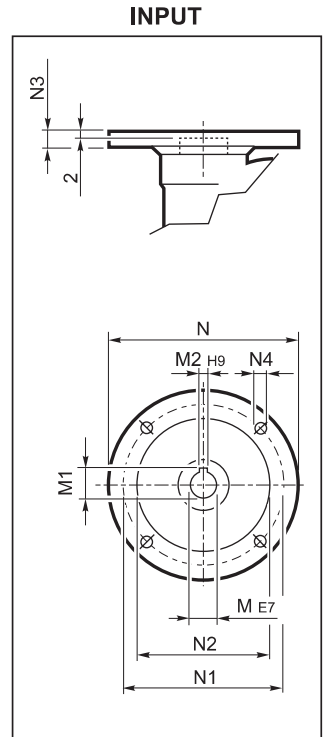
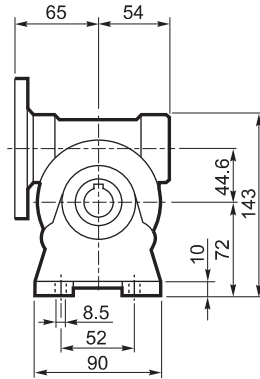
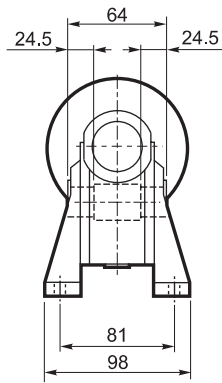

N

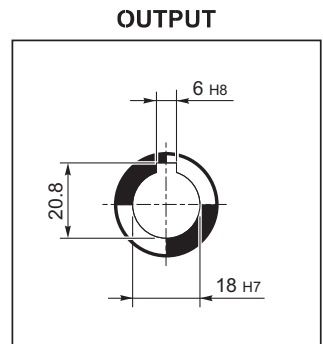
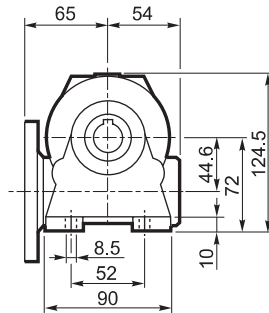
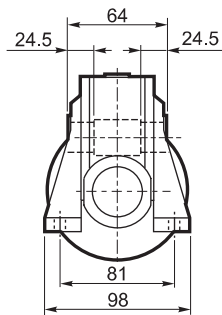

V

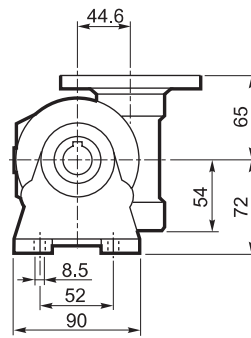
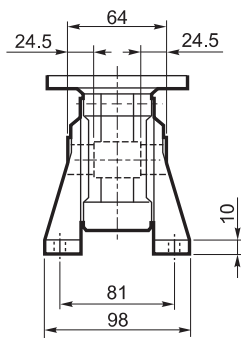

P

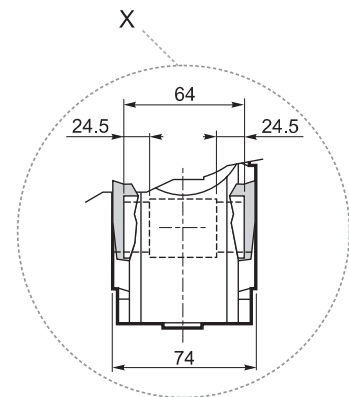
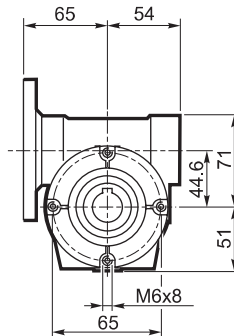
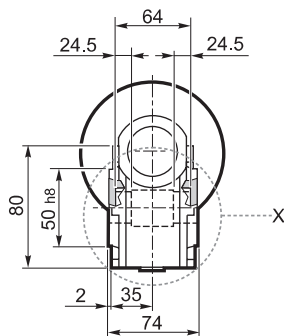



VF 44...P (IEC)

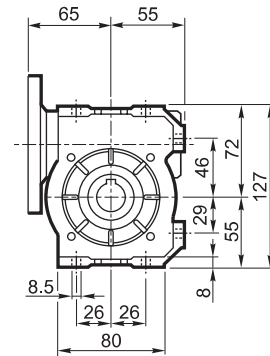
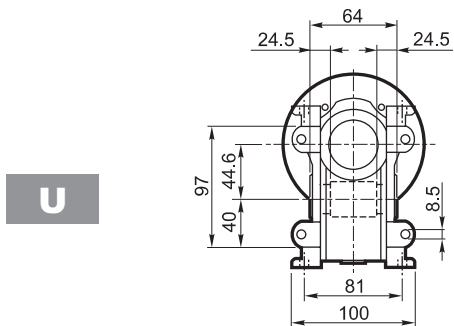
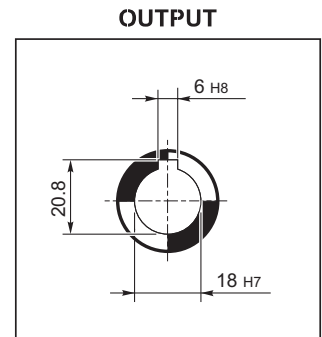
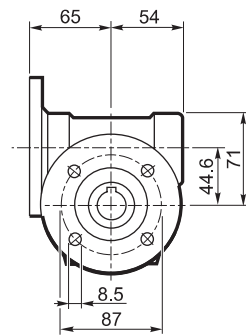
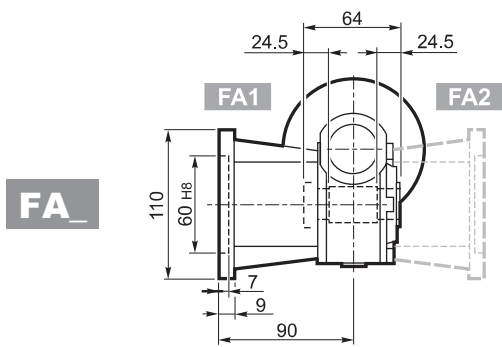
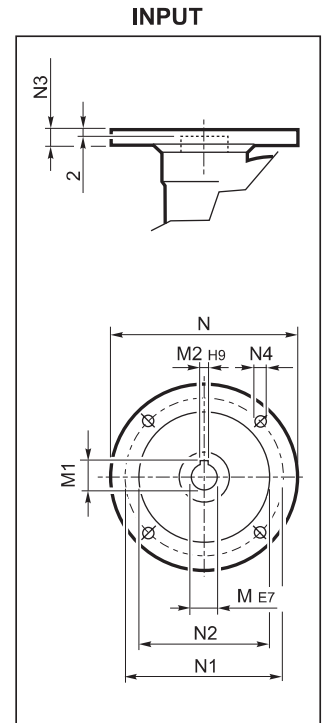
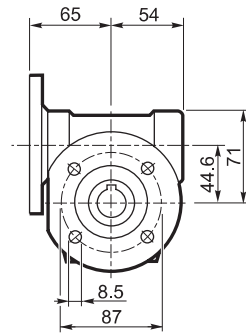
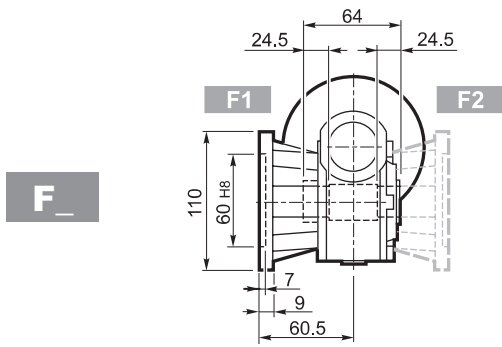

		M	M1	M2	N	N1	N2	N3	N4	
VF 44	P63 B5	11	12.8	4	140	115	95	10	9.5	2.0
VF 44	P71 B5	14	16.3	5	160	130	110	10	9.5	
VF 44	P63 B14	11	12.8	4	90	75	60	8	5.5	
VF 44	P71 B14	14	16.3	5	105	85	70	10	7	



VFR 44...BN 44

A

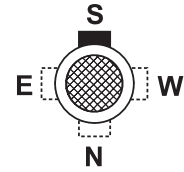
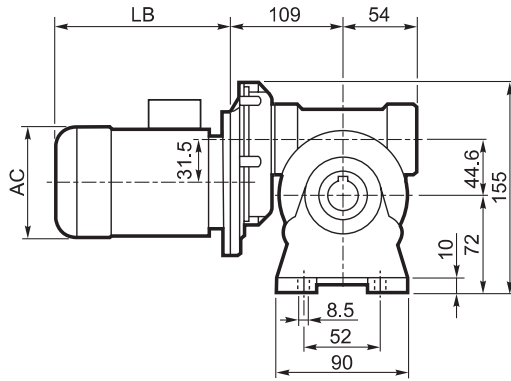
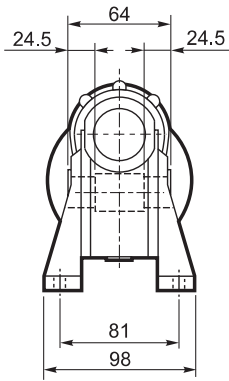

OUTPUT

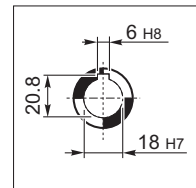

N

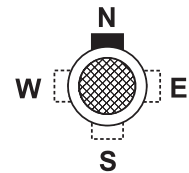
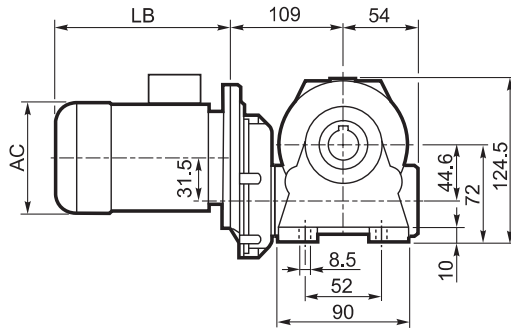
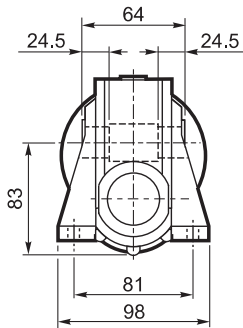

V

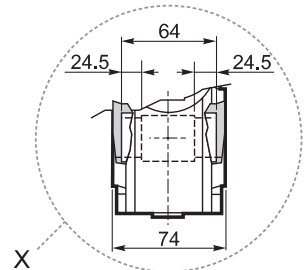
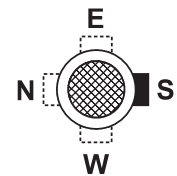
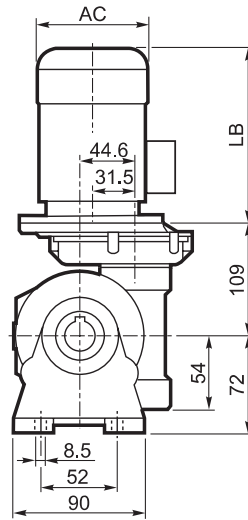
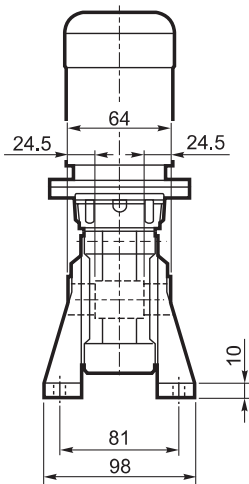

P

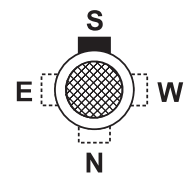
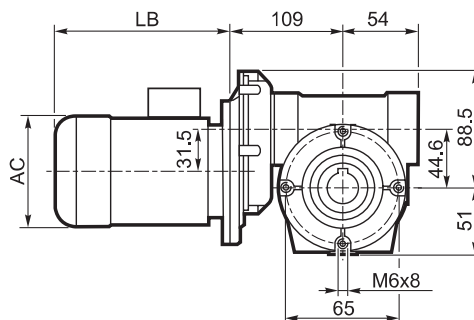
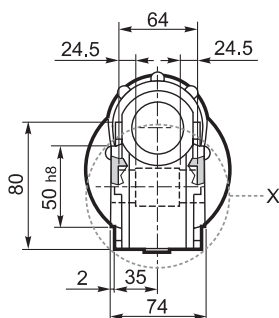



VFR 44...BN 44

F_

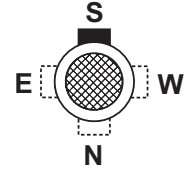
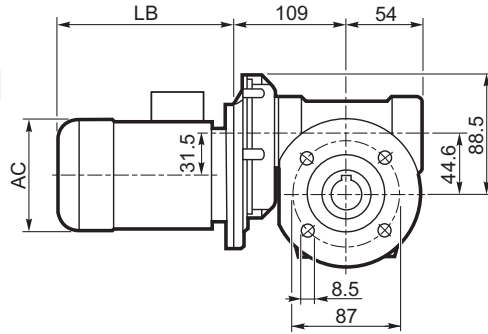
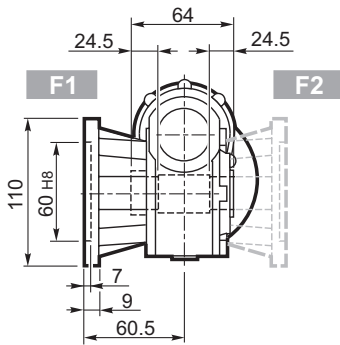

OUTPUT

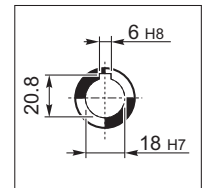

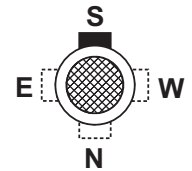
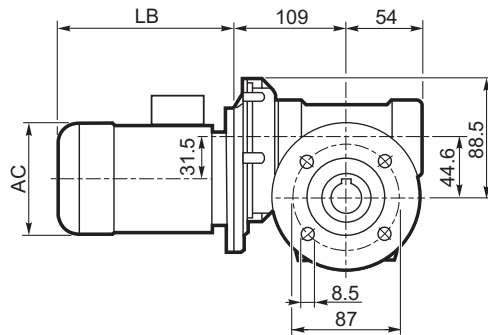
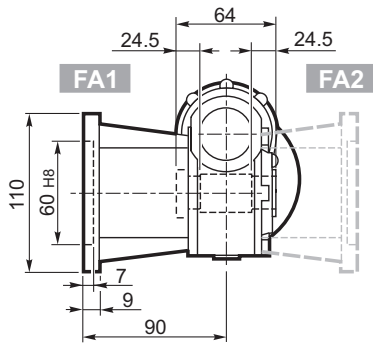

FA_

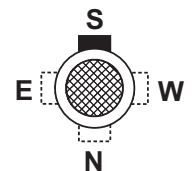
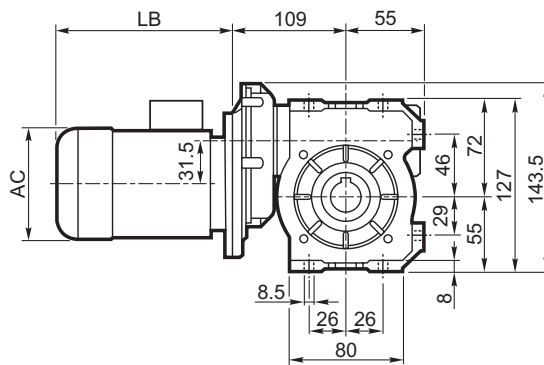
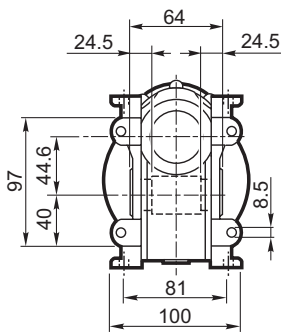

U



	P_n kW	n min ⁻¹	M_n Nm	η %	$\cos\phi$	I_n A (400V)	$\frac{I_s}{I_n}$	$\frac{M_s}{M_n}$	$\frac{M_a}{M_n}$	J_m ($\cdot 10^{-4}$) kgm ²	 Kg	LB	AC	AD
BN 44B4	0.06	1380	0.42	40	0.58	0.38	2.4	2.3	1.9	1.22	4.7	168	112	94
BN 44C4	0.09	1380	0.63	46	0.65	0.43	2.8	2.3	2	1.49	4.6	168	112	94



VF/VF 30/44...P (IEC)

A

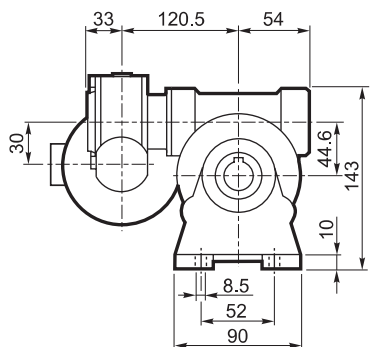

N

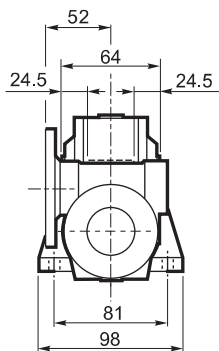

V

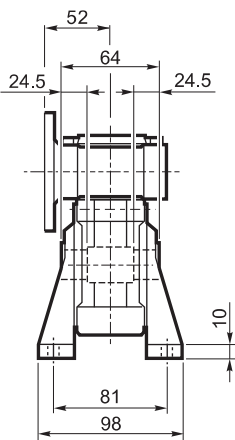

P

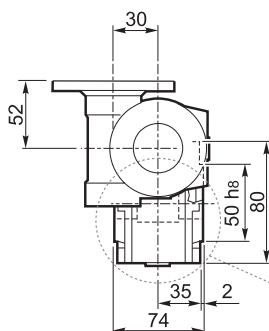
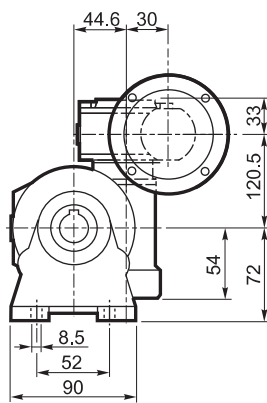
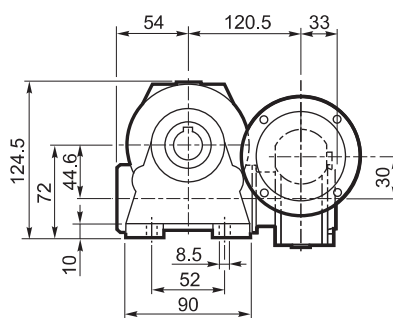
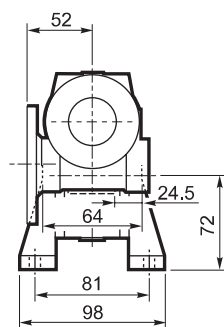
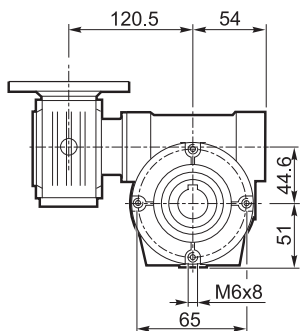

INPUT

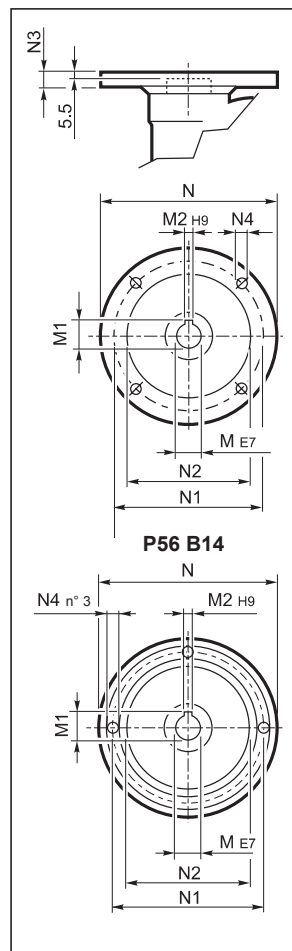

OUTPUT

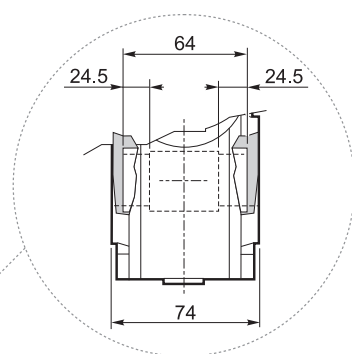
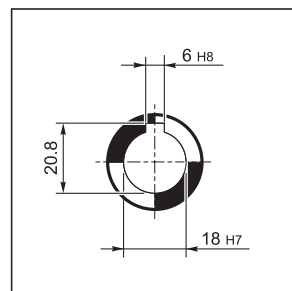



VF/VF 30/44...P (IEC)

F₋

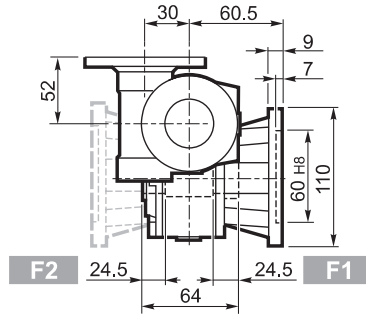
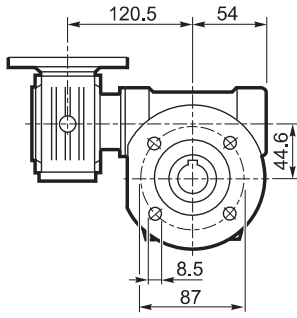

INPUT

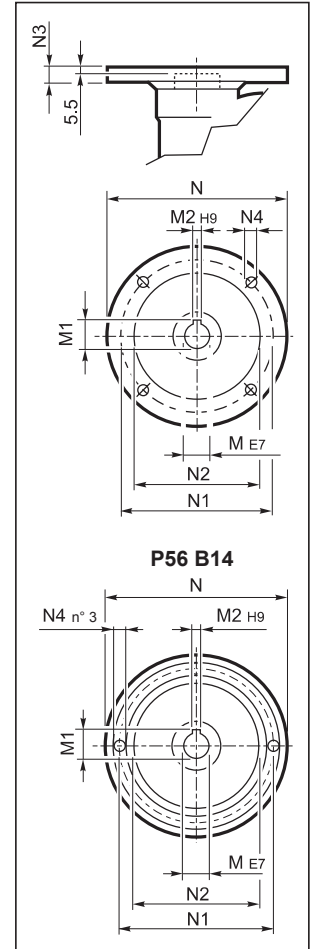

FA₋

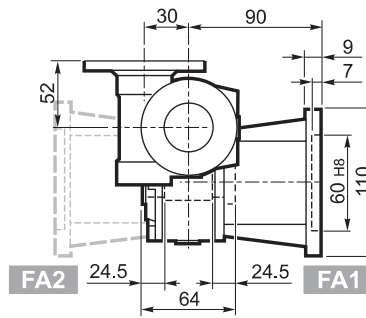
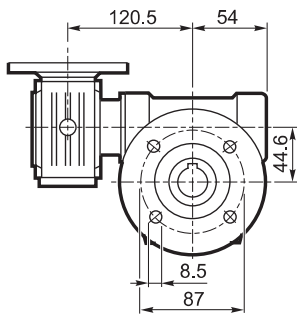

OUTPUT

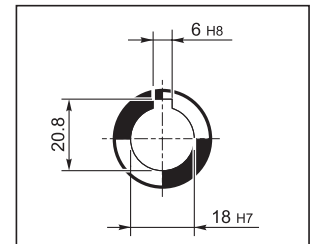

U

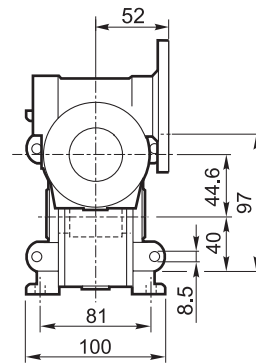
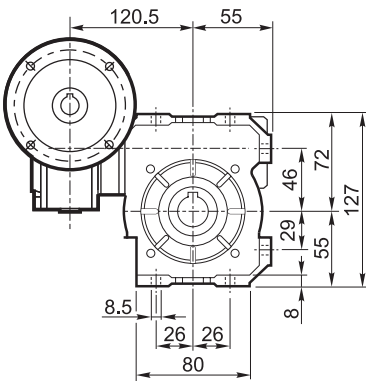

		M	M1	M2	N	N1	N2	N3	N4	
VF/VF 30/44	P56 B14	9	10.4	3	80	65	50	7	5.5	3.5
VF/VF 30/44	P63 B14	11	12.8	4	90	75	60	6	5.5	



VF 49...P (IEC)

A

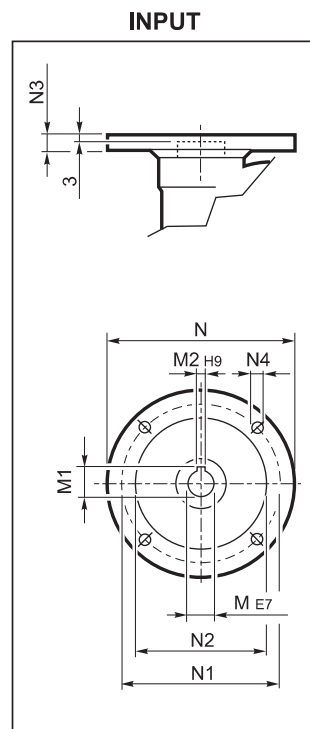
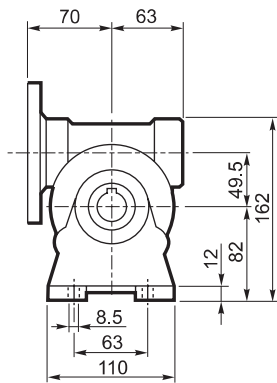
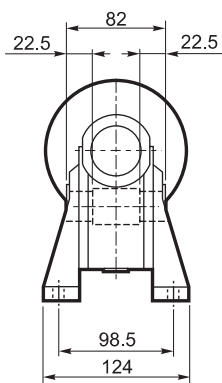

N

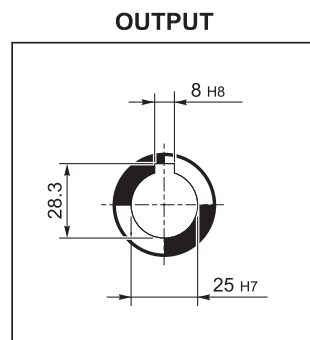
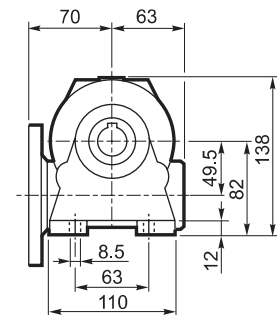
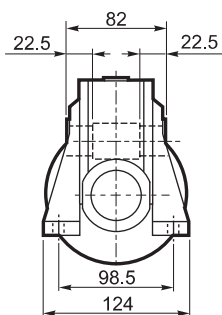

V

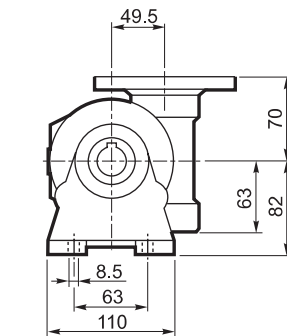
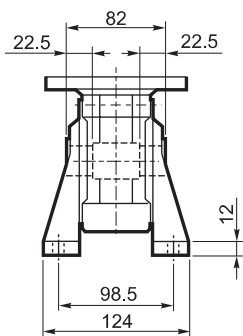

P

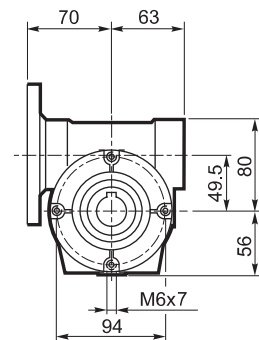
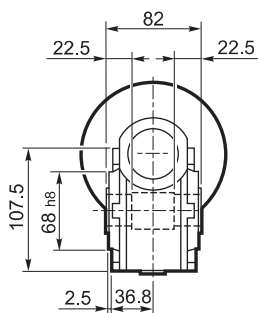



VF 49...P (IEC)

F_

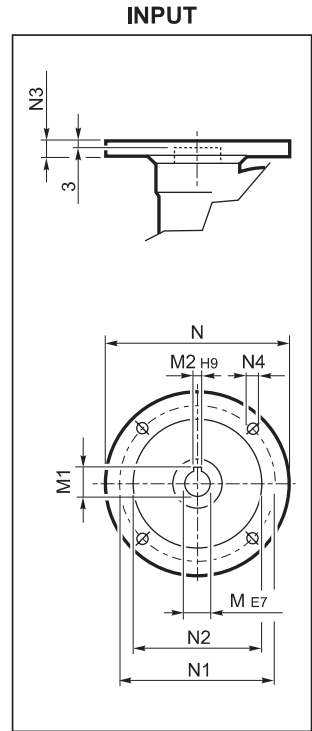
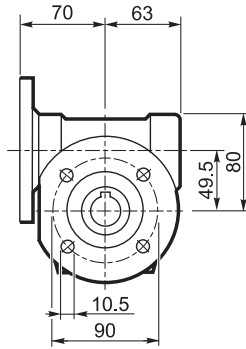
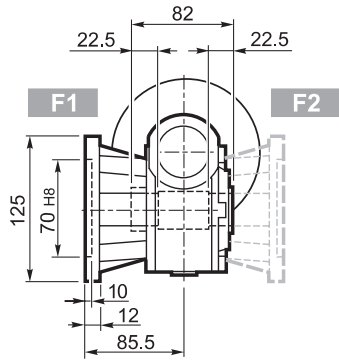

FA_

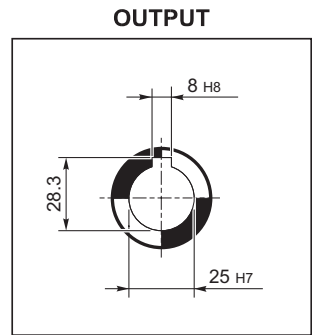
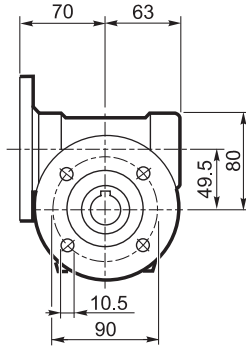
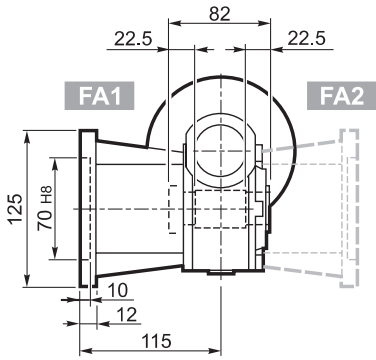

U

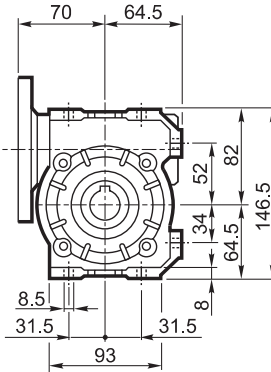
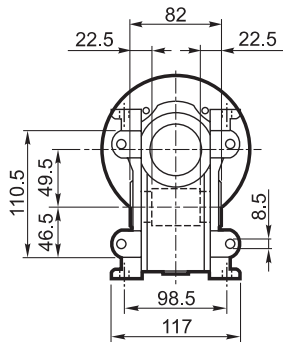

		M	M1	M2	N	N1	N2	N3	N4	
VF 49	P63 B5	11	12.8	4	140	115	95	10.5	9.5	3.0
VF 49	P71 B5	14	16.3	5	160	130	110	10.5	9.5	
VF 49	P80 B5	19	21.8	6	200	165	130	10	11.5	
VF 49	P63 B14	11	12.8	4	90	75	60	7	6	
VF 49	P71 B14	14	16.3	5	105	85	70	10.5	6.5	
VF 49	P80 B14	19	21.8	6	120	100	80	10	7	



VFR 49...P (IEC)

A

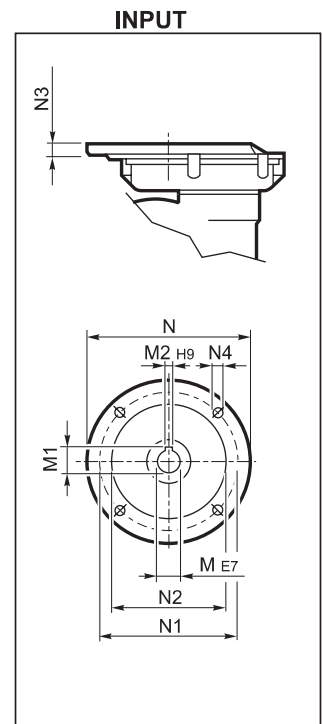
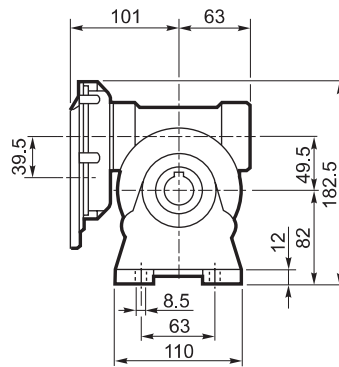
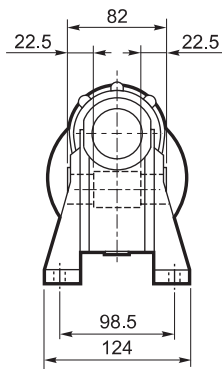

N

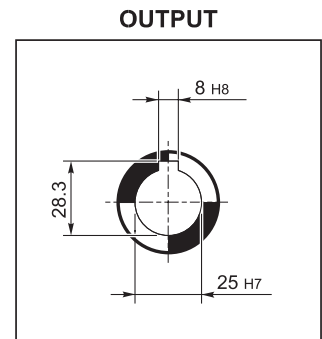
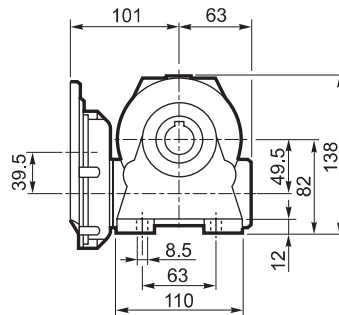
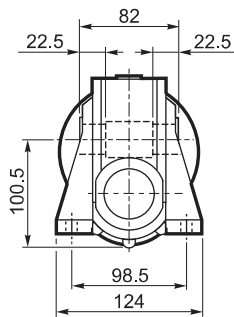

V

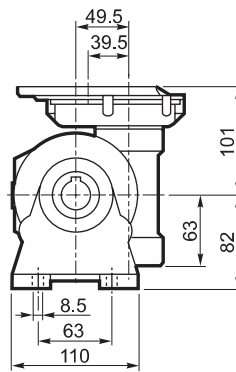
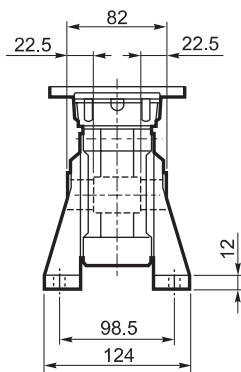

P

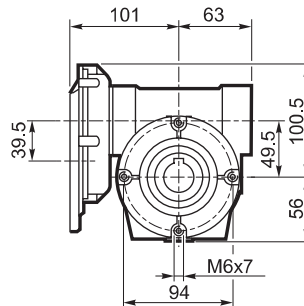
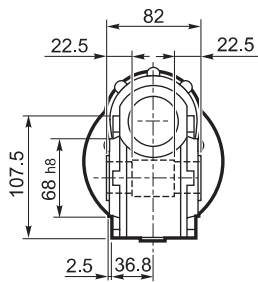



VFR 49...P (IEC)

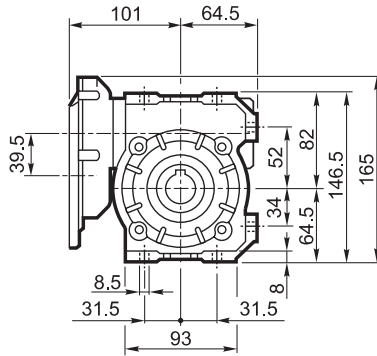
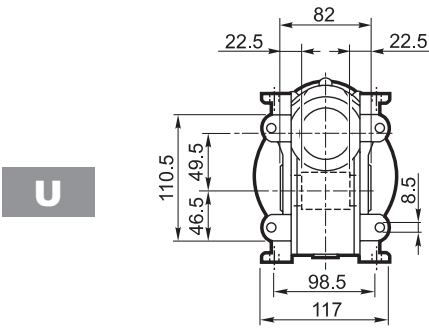
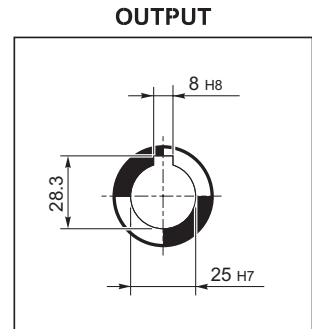
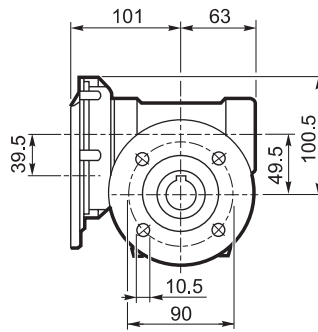
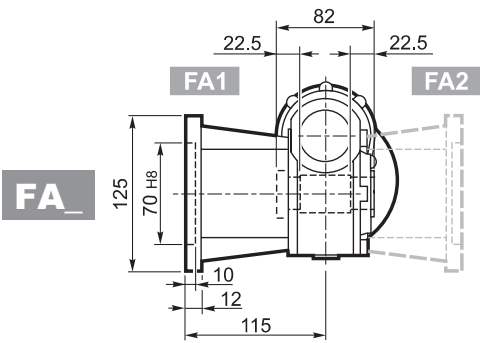
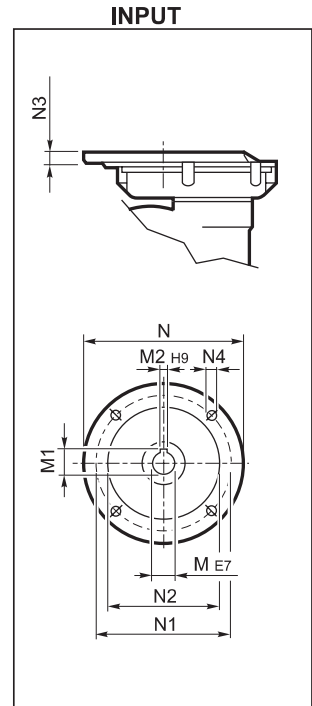
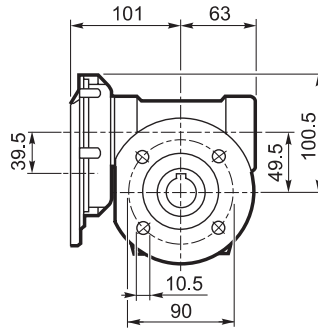
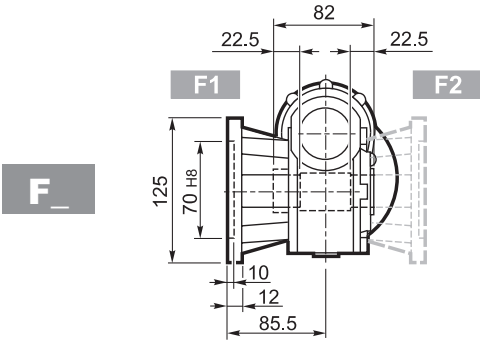

		M	M1	M2	N	N1	N2	N3	N4	
VFR 49	P63 B5	11	12.8	4	140	115	95	11	M8 x 19	5.0



VF/VF 30/49...P (IEC)

A

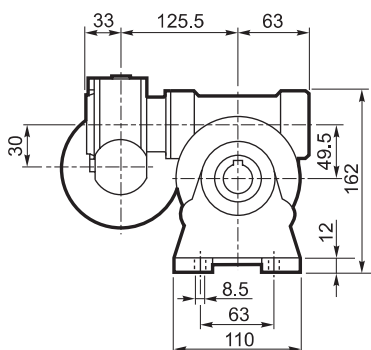

N

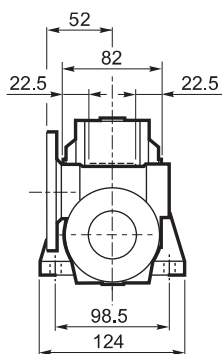

V

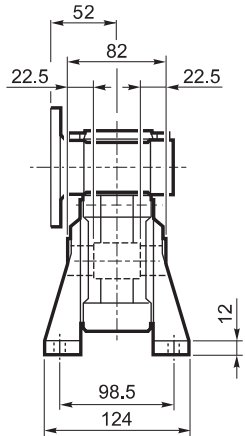

P

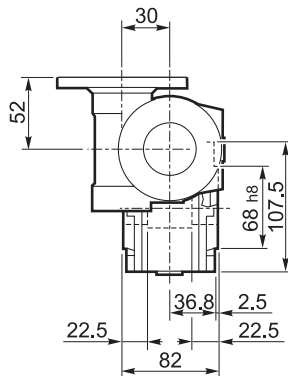
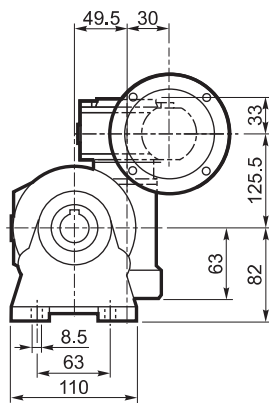
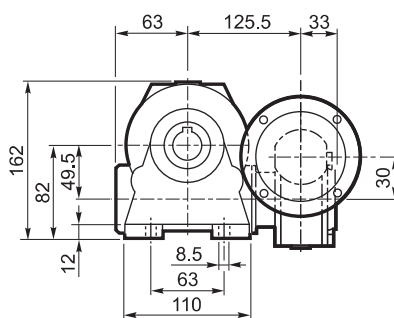
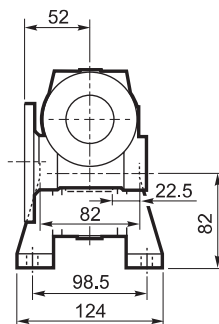
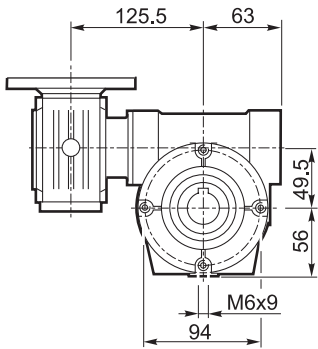

INPUT

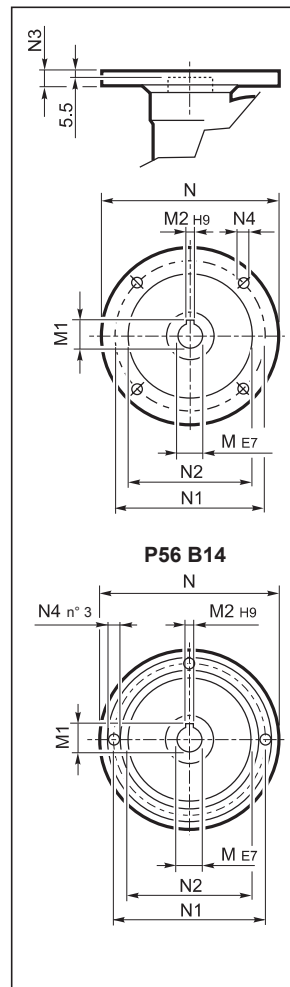

OUTPUT

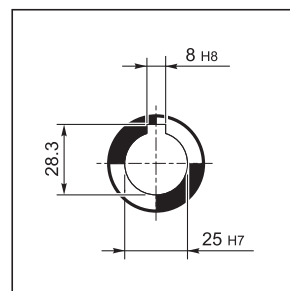



VF/VF 30/49...P (IEC)

F

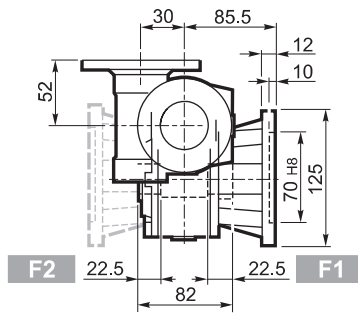
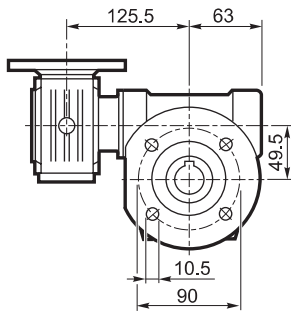

FA

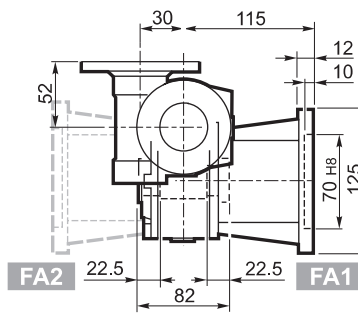
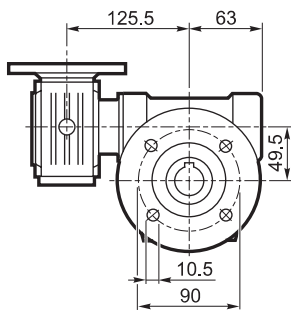

U

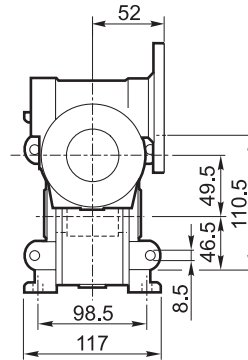
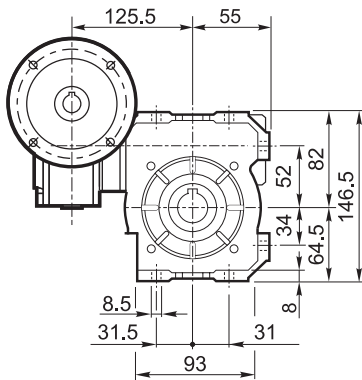

INPUT

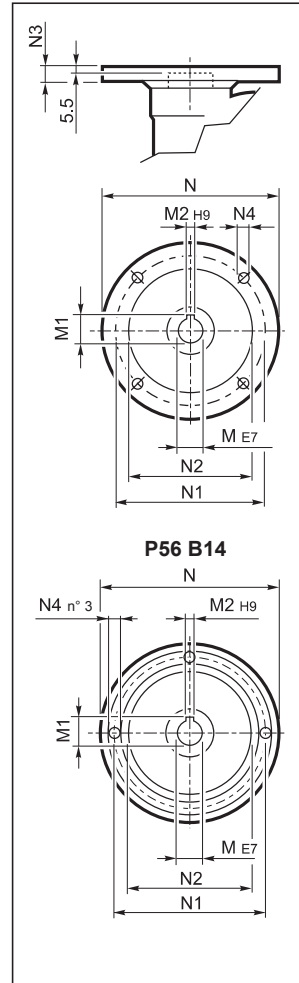

OUTPUT

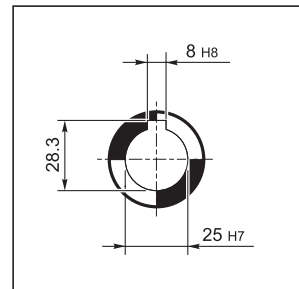

		M	M1	M2	N	N1	N2	N3	N4	
VF/VF 30/49	P56 B14	9	10.4	3	80	65	50	7	5.5	4.5
VF/VF 30/49	P63 B14	11	12.8	4	90	75	60	6	5.5	



W 63...M

U

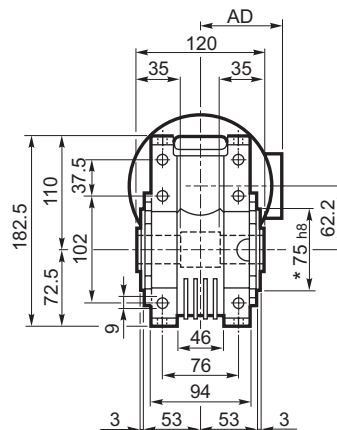
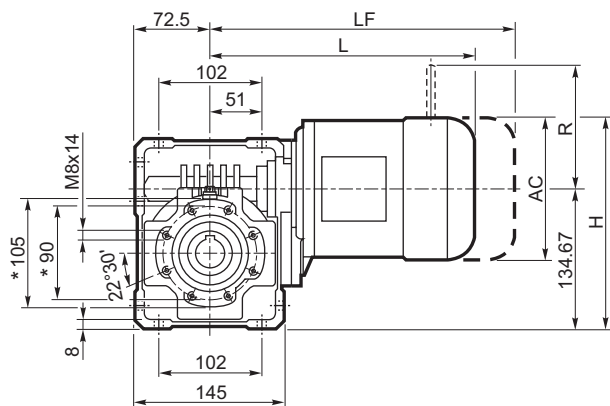

UF_

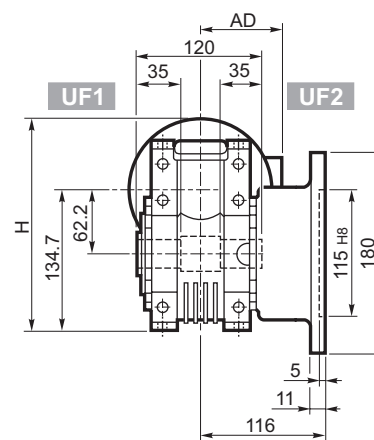
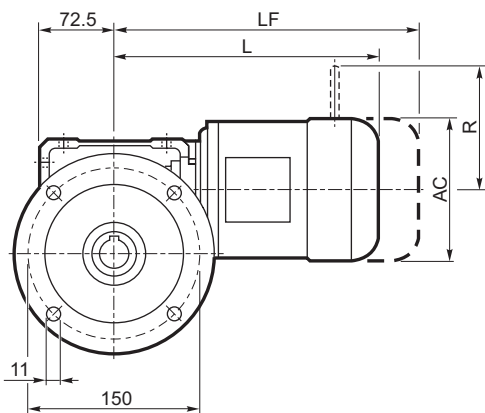

UFC_

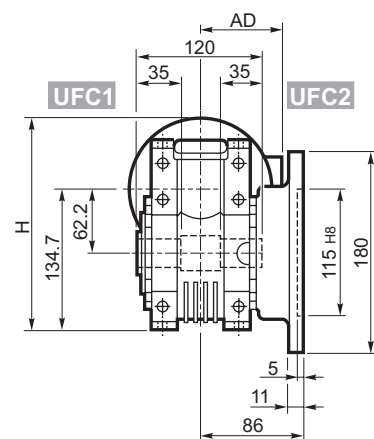
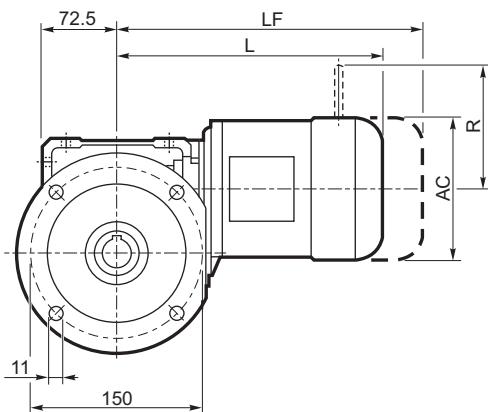

OUTPUT

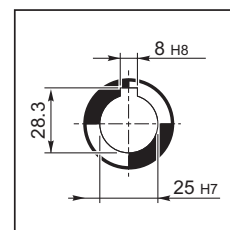

			M_				Kg	M...FD M...FA		M...FD		M...FA	
			AC	H	L	AD		LF	Kg	R	AD	R	AD
W 63	S1	M1	138	204	289	108	13	350	15	103	135	124	108
W 63	S2	M2S	156	213	317	119	17	393	20	129	146	134	119

* De ambos lados



W 63...P (IEC)

U

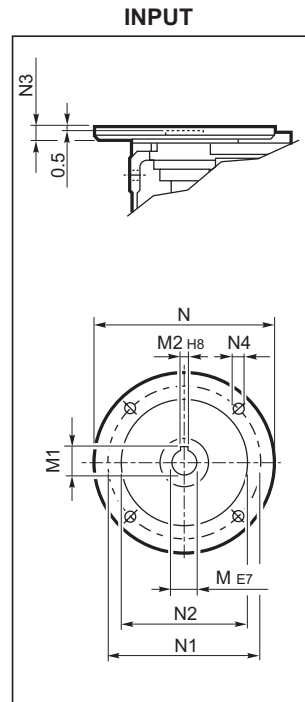
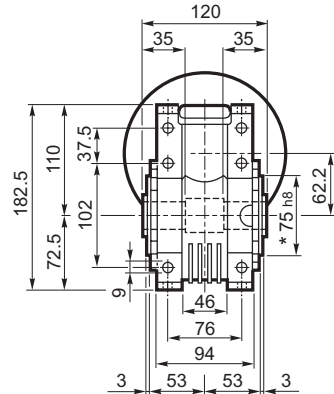
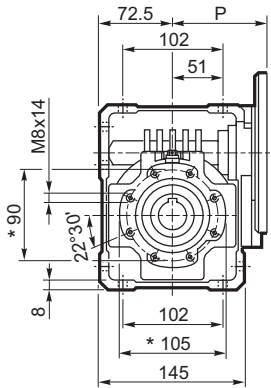

UF_

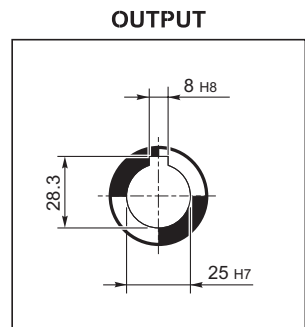
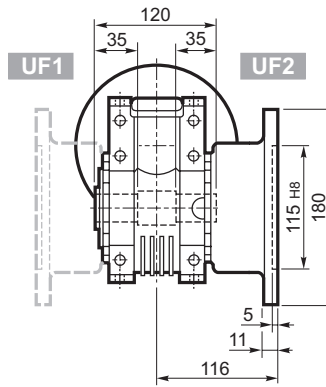
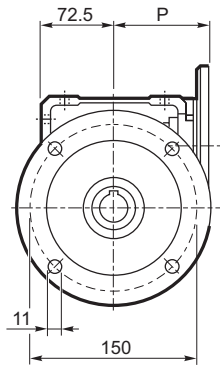

UFC_

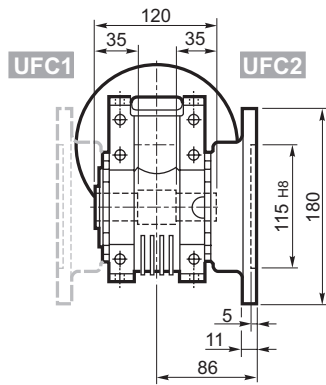
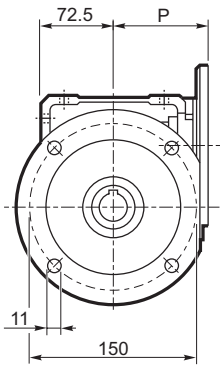

		M	M1	M2	N	N1	N2	N3	N4	P	kg
		14	16.3	5	160	130	110	11	9	95	6.3
W 63	P71 B5	14	16.3	5	160	130	110	11	9	95	6.3
W 63	P80 B5	19	21.8	6	200	165	130	12	11.5	102	6.5
W 63	P90 B5	24	27.3	8	200	165	130	12	11.5	102	6.4
W 63	P71 B14	14	16.3	5	105	85	70	11	6.5	95	6.1
W 63	P80 B14	19	21.8	6	120	100	80	11	6.5	102	6.3
W 63	P90 B14	24	27.3	8	140	115	95	11	8.5	102	6.3



WR 63...P (IEC)

U

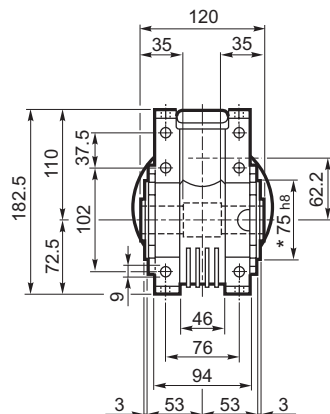
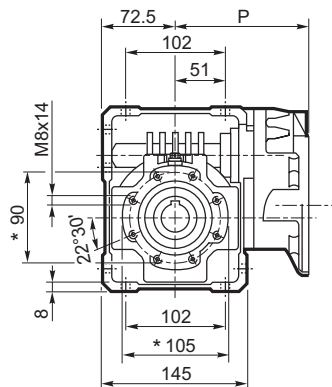

INPUT

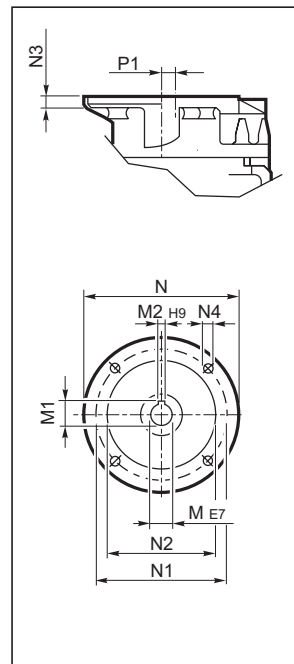

UF

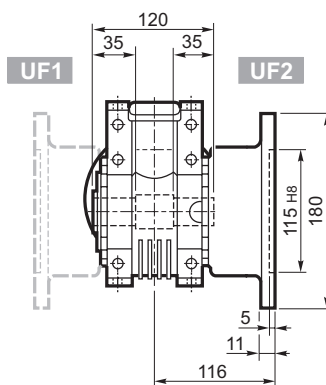
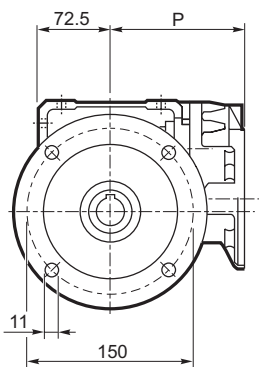

OUTPUT

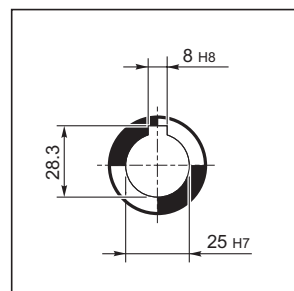

UFC

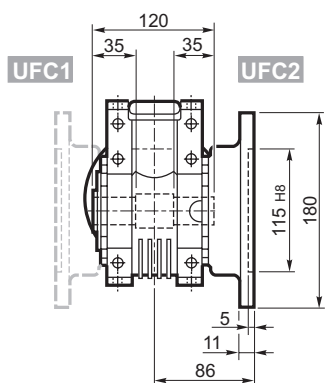
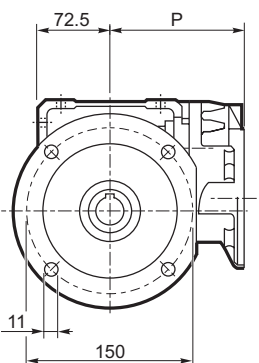

		M	M1	M2	N	N1	N2	N3	N4	P	P1	
WR 63	P63 B5	11	12.8	4	140	115	95	10	M8x10	133.5	11.42	7.1
WR 63	P71 B5	14	16.3	5	160	130	110	10	M8x10	133.5	11.42	

* De ambos lados

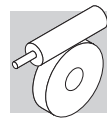

VF/W 30/63...P (IEC)

U

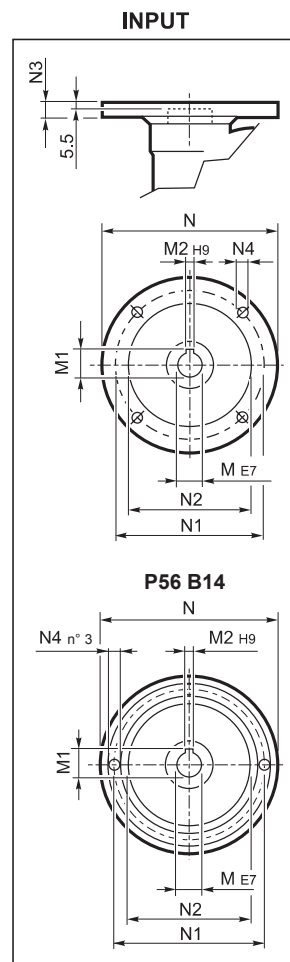
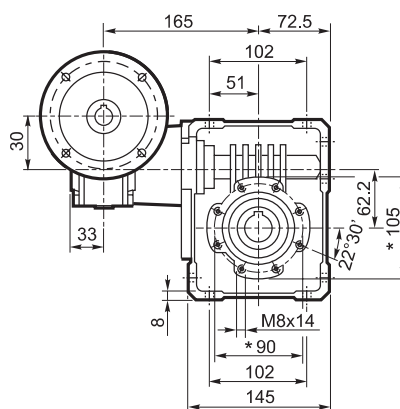
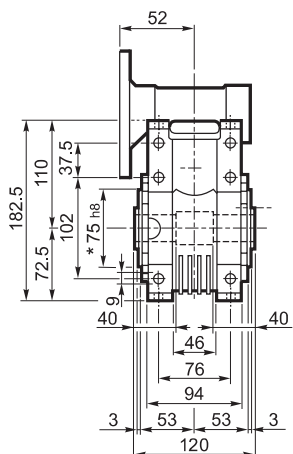

UF

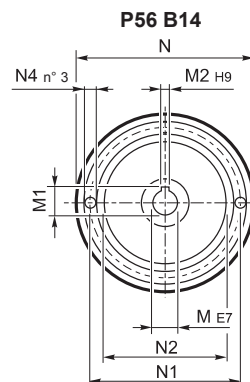
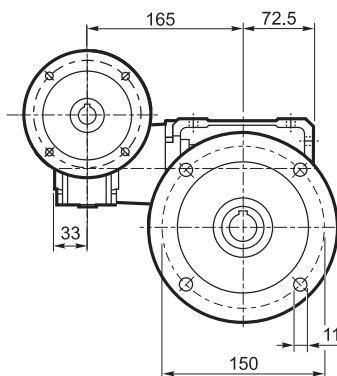
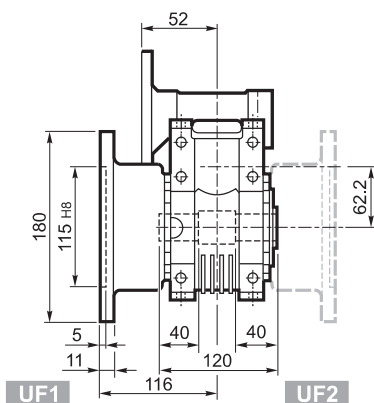

UFC

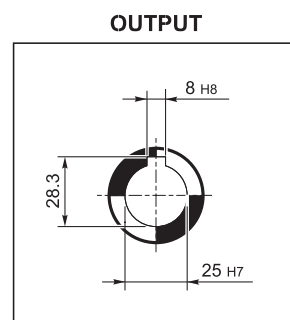
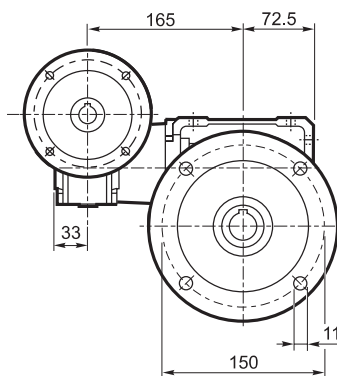
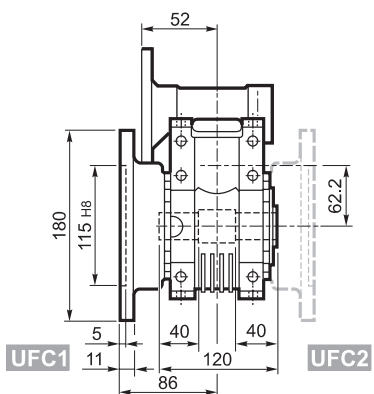

		M	M1	M2	N	N1	N2	N3	N4	Kg
VF/W 30/63	P56 B5	9	10.4	3	120	100	80	7	7	8.0
VF/W 30/63	P63 B5	11	12.8	4	140	115	95	8	9.5	
VF/W 30/63	P56 B14	9	10.4	3	80	65	50	7	5.5	
VF/W 30/63	P63 B14	11	12.8	4	90	75	60	6	5.5	

* De ambos lados



W 75...M

U

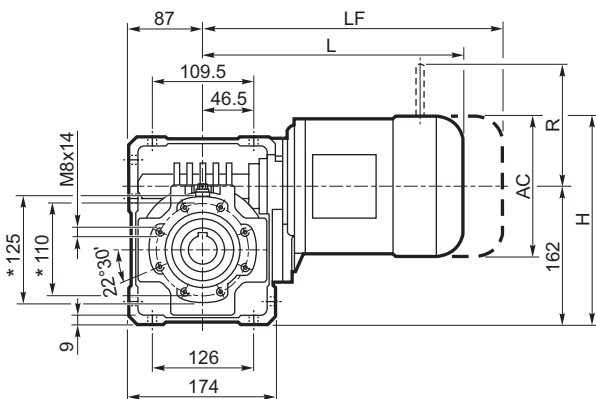

UF_

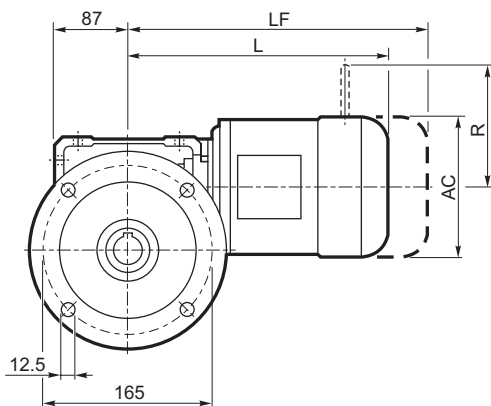

UFC_

UFCR_#

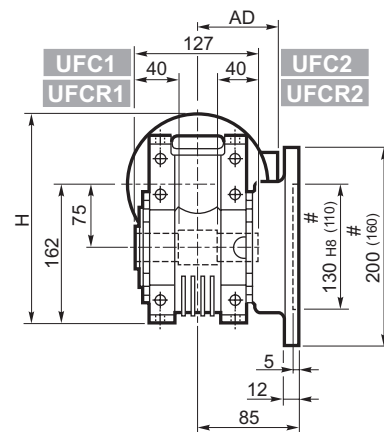
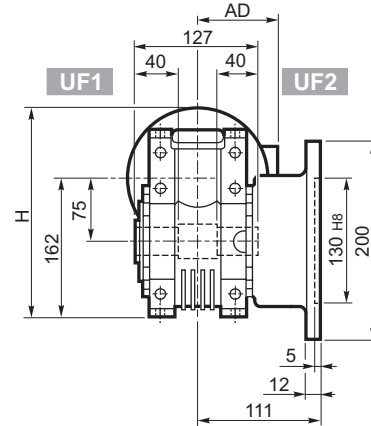
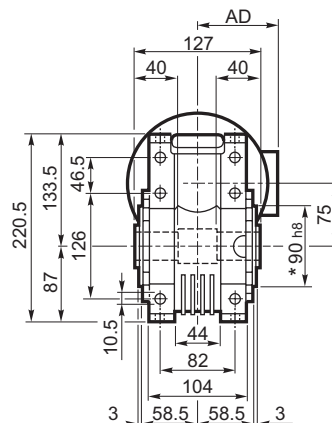
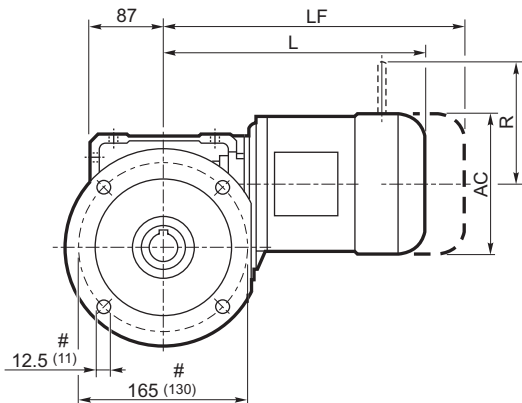

STANDARD OUTPUT

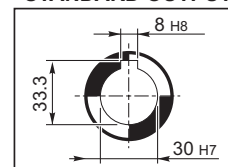

ON REQUEST OUTPUT

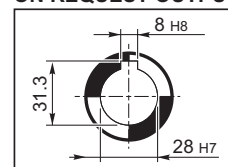

Icon	S	M	M_				M...FD		M...FA		M...FD		M...FA	
			AC	H	L	AD	kg	LF	kg	R	AD	R	AD	
	W 75	S1	M1	138	231	308	108	16.0	369	18.2	103	135	124	108
	W 75	S2	M2S	153	240	333	119	18.5	409	21.6	129	146	134	119
	W 75	S3	M3S	193	258.5	376	142	25.6	472	31	160	158	160	142
	W 75	S3	M3L	193	258.5	408	142	28.6	499	34	160	158	160	142

* De ambos lados

Brida reducida



W 75...P (IEC)

U

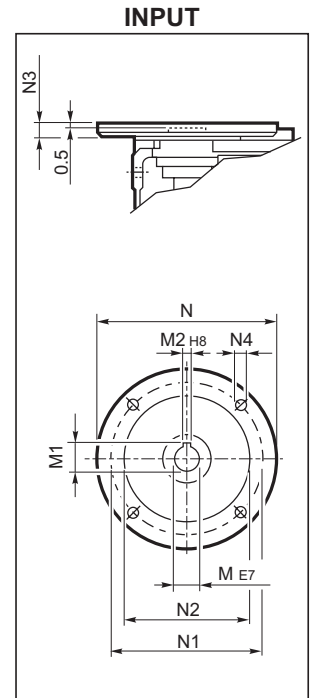
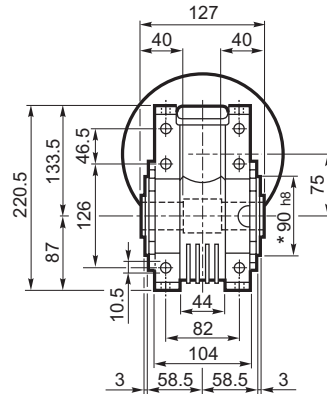
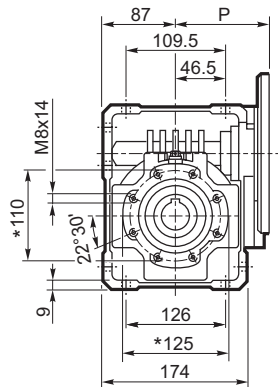

UF_

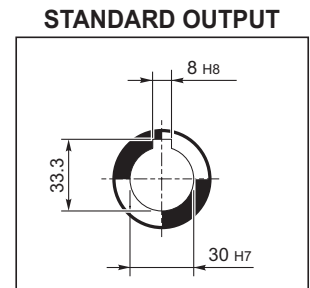
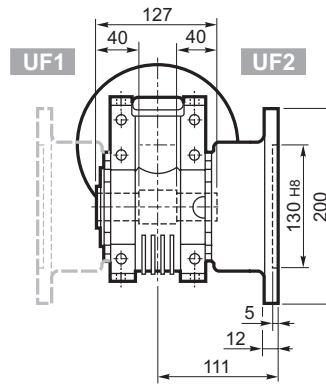
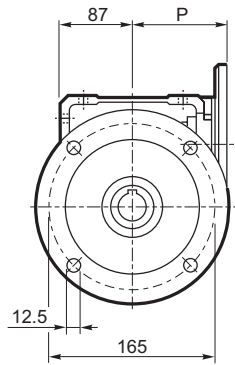

STANDARD OUTPUT

UFC_

UF CR #

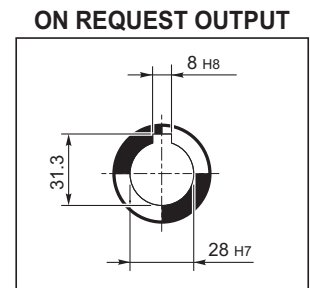
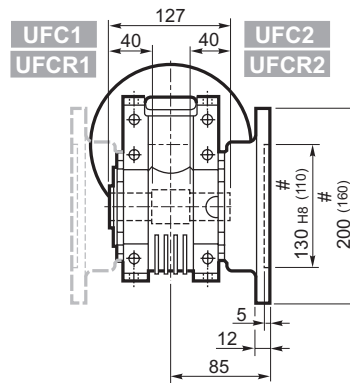
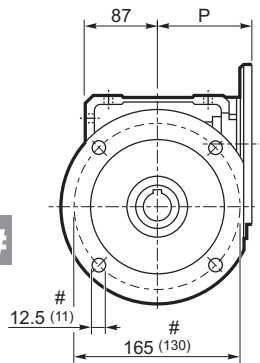

ON REQUEST OUTPUT

		M	M1	M2	N	N1	N2	N3	N4	P	
W 75	P71 B5	14	16.3	5	160	130	110	11	9	112	9.5
W 75	P80 B5	19	21.8	6	200	165	130	12	11.5	112	9.7
W 75	P90 B5	24	27.3	8	200	165	130	12	11.5	112	9.6
W 75	P100 B5	28	31.3	8	250	215	180	13	12.5	120	9.7
W 75	P112 B5	28	31.3	8	250	215	180	13	12.5	120	9.7
W 75	P80 B14	19	21.8	6	120	100	80	7.5	6.5	112	9.4
W 75	P90 B14	24	27.3	8	140	115	95	7.5	8.5	112	9.4
W 75	P100 B14	28	31.3	8	160	130	110	10	8.5	120	9.5
W 75	P112 B14	28	31.3	8	160	130	110	10	8.5	120	9.5

* De ambos lados

Brida reducida



WR 75...P (IEC)

U

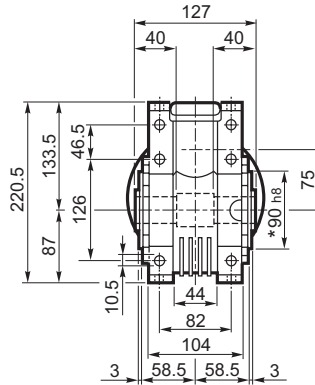
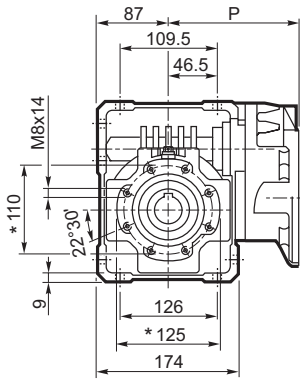

INPUT

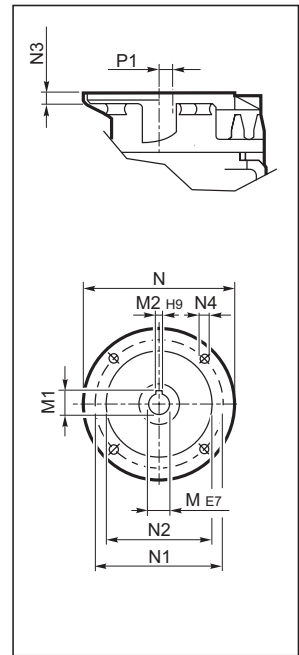

UF_

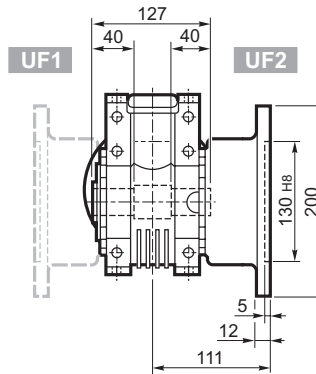
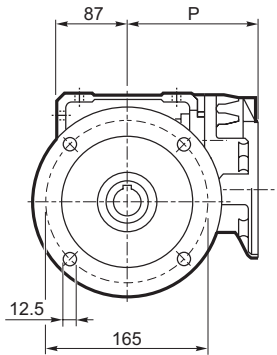

STANDARD OUTPUT

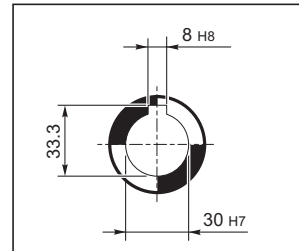

UFC_

UFCR #

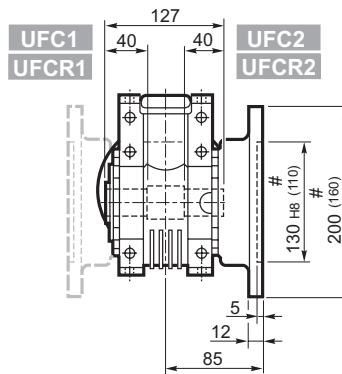
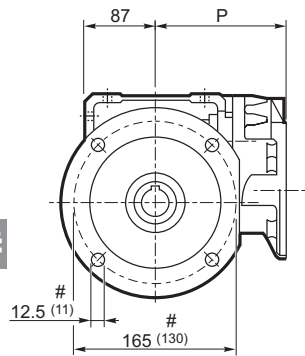

ON REQUEST OUTPUT

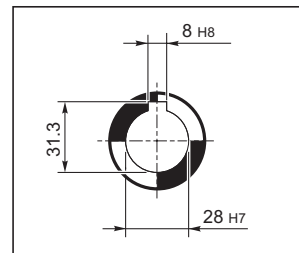

		M	M1	M2	N	N1	N2	N3	N4	P	P1	
WR 75	P63 B5	11	12.8	4	140	115	95	10	M8x10	152	23.53	10.6
WR 75	P71 B5	14	16.3	5	160	130	110	10	M8x10	152	23.53	10.7
WR 75	P80 B5	19	21.8	6	200	165	130	12	M10x13	163.5	11	11.5
WR 75	P90 B5	24	27.3	8	200	165	130	12	M10x13	163.5	11	11.6

* De ambos lados

Brida reducida

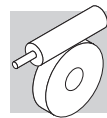

VF/W 44/75...P (IEC)

U

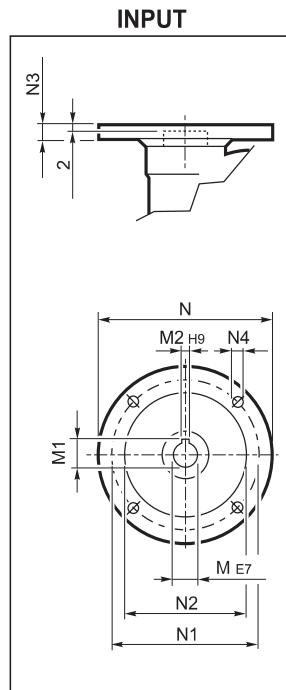
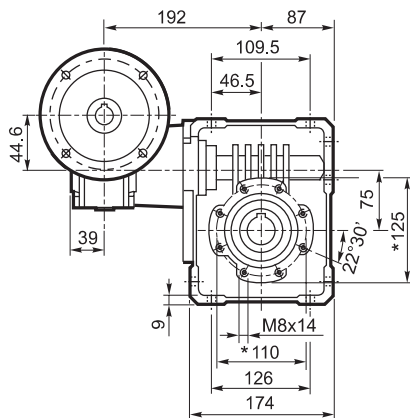
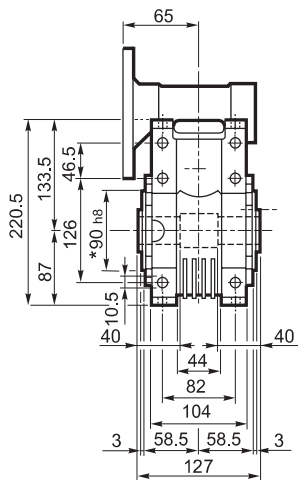

UF

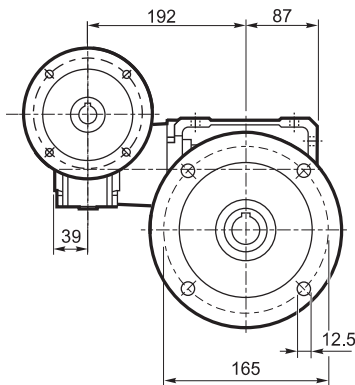
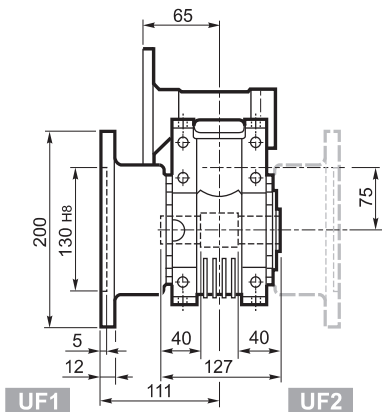

STANDARD OUTPUT

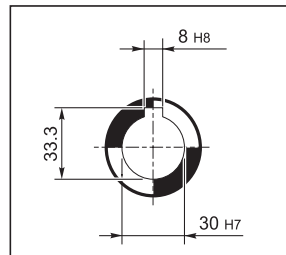

UFC

UFCR #

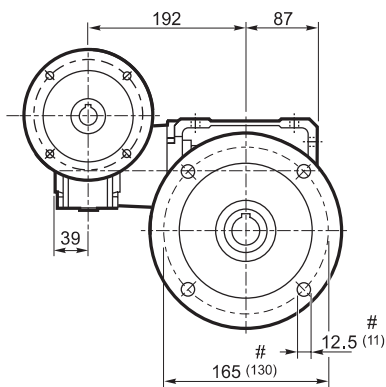
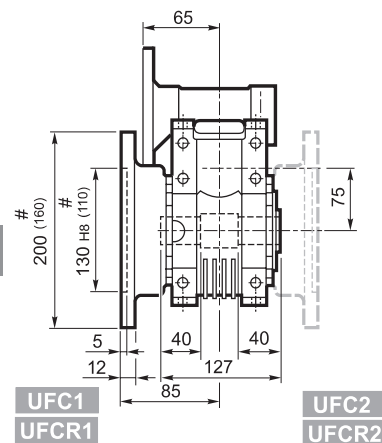

ON REQUEST OUTPUT

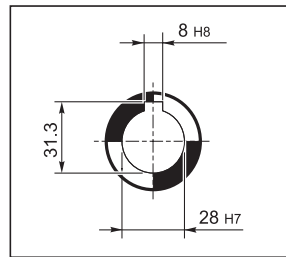

		M	M1	M2	N	N1	N2	N3	N4	Kg
VF/W 44/75	P63 B5	11	12.8	4	140	115	95	10	9.5	12.5
VF/W 44/75	P71 B5	14	16.3	5	160	130	110	10	9.5	
VF/W 44/75	P63 B14	11	12.8	4	90	75	60	8	5.5	
VF/W 44/75	P71 B14	14	16.3	5	105	85	70	10	7	

* De ambos lados

Brida reducida



W 86...M

U

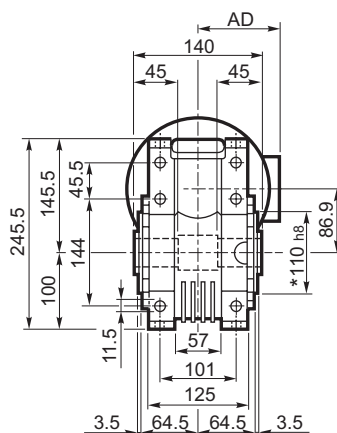
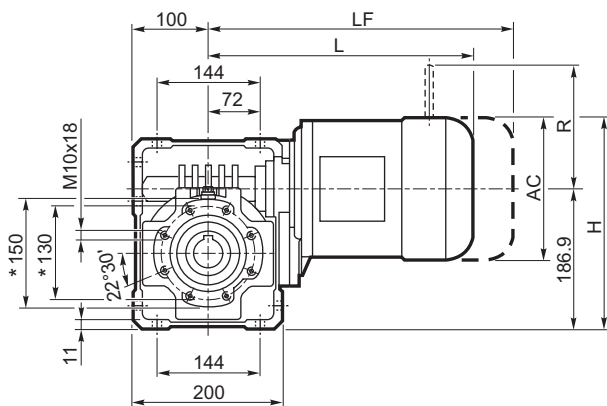

UF

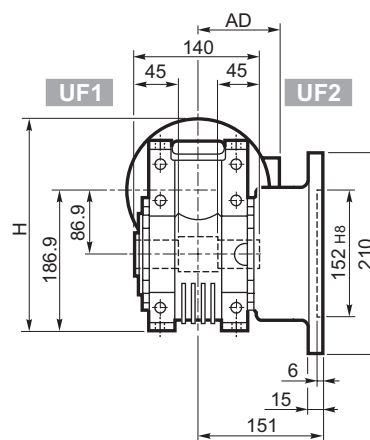
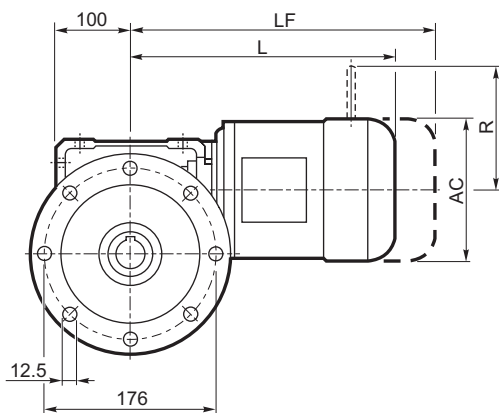

UFC

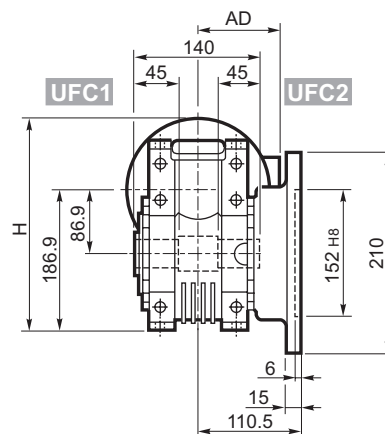
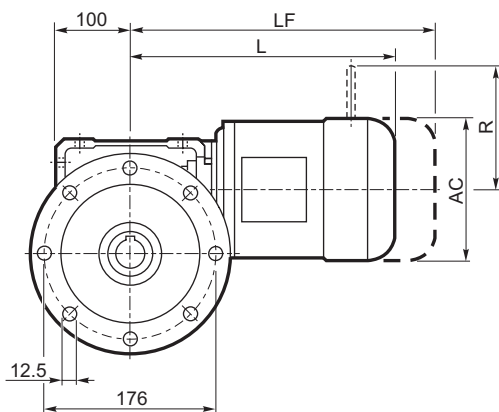

Icon	M ₋							M...FD M...FA		M...FD		M...FA	
	AC	H	L	AD		LF		R	AD	R	AD		
	138	256	324	108	20.1	385	22.3	103	135	124	108		
	156	265	349	119	22.6	425	25.7	129	146	134	119		
	193	283.5	392	142	29.7	488	35	160	158	160	142		
	193	283.5	424	142	33	515	36	160	158	160	142		

OUTPUT

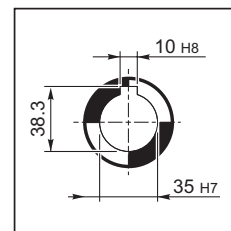

* De ambos lados



W 86...P (IEC)

U

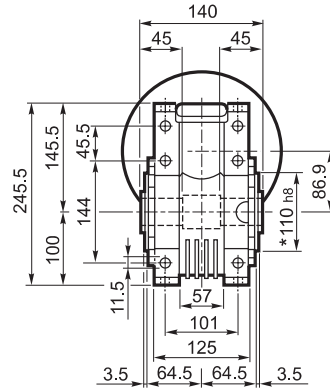
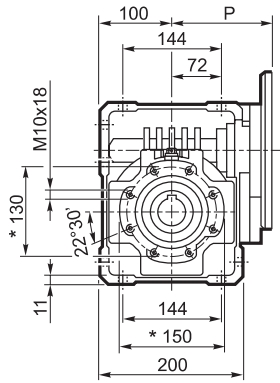

INPUT

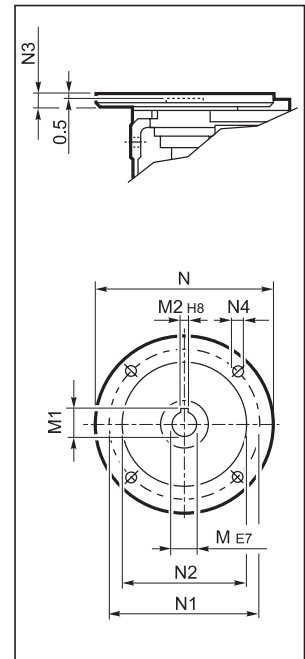

UF

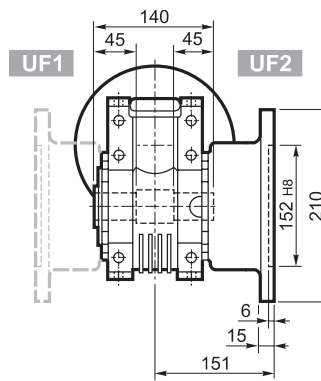
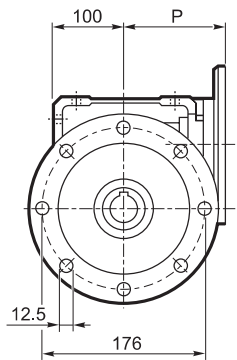

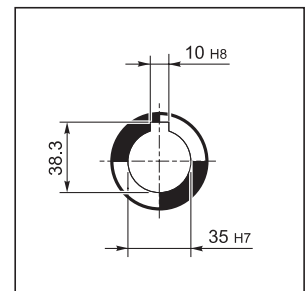

OUTPUT

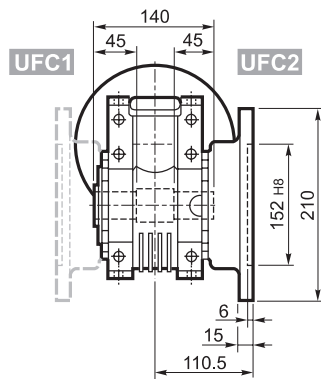
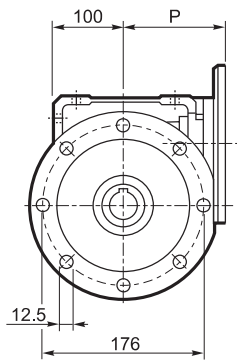

UFC



		M	M1	M2	N	N1	N2	N3	N4	P	
W 86	P71 B5	14	16.3	5	160	130	110	11	9	128	13.6
W 86	P80 B5	19	21.8	6	200	165	130	12	11.5	128	13.8
W 86	P90 B5	24	27.3	8	200	165	130	12	11.5	128	13.7
W 86	P100 B5	28	31.3	8	250	215	180	13	12.5	136	13.8
W 86	P112 B5	28	31.3	8	250	215	180	13	12.5	136	13.8
W 86	P80 B14	19	21.8	6	120	100	80	7.5	6.5	128	13.5
W 86	P90 B14	24	27.3	8	140	115	95	7.5	8.5	128	13.5
W 86	P100 B14	28	31.3	8	160	130	110	10	8.5	136	13.6
W 86	P112 B14	28	31.3	8	160	130	110	10	8.5	136	13.6

* De ambos lados



WR 86...P (IEC)

U

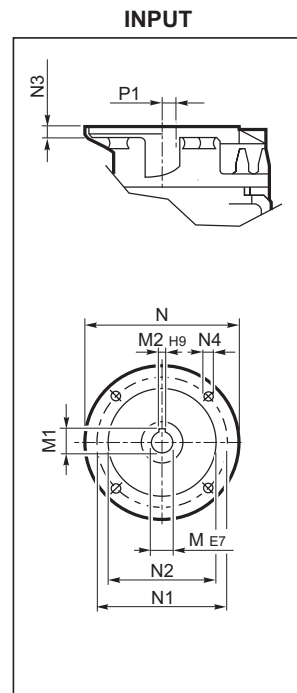
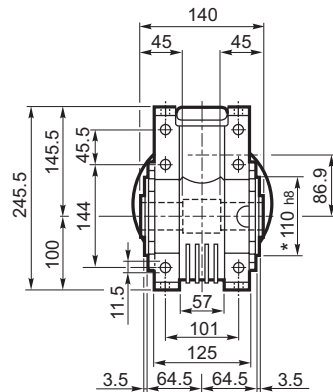
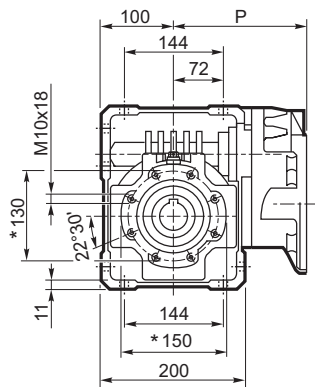

UF

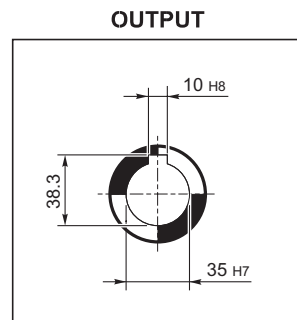
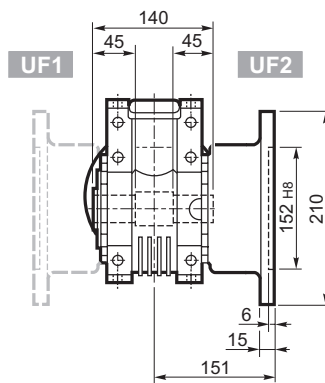
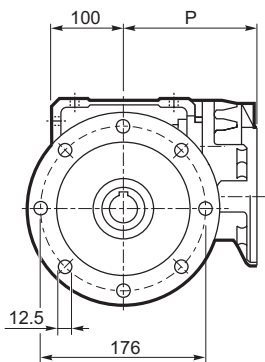

UFC

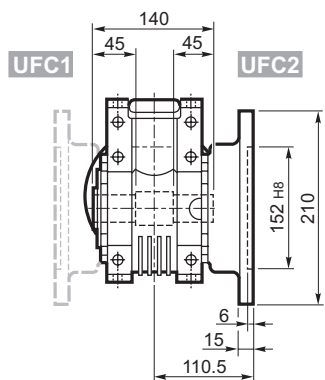
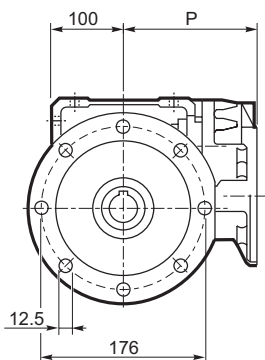

		M	M1	M2	N	N1	N2	N3	N4	P	P1	
WR 86	P63 B5	11	12.8	4	140	115	95	10	M8x10	168	35.4	14.3
WR 86	P71 B5	14	16.3	5	160	130	110	10	M8x10	168	35.4	14.4
WR 86	P80 B5	19	21.8	6	200	165	130	12	M10x13	179.5	22.9	15.2
WR 86	P90 B5	24	27.3	8	200	165	130	12	M10x13	179.5	22.9	15.3

* De ambos lados

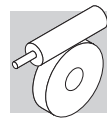

VF/W 44/86... P (IEC)

U

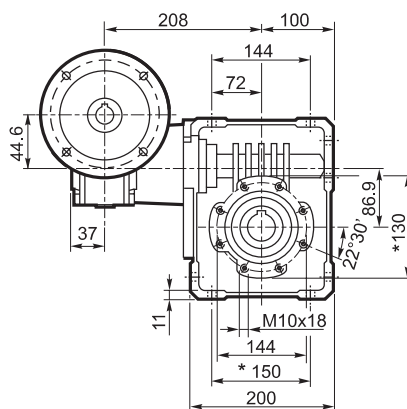
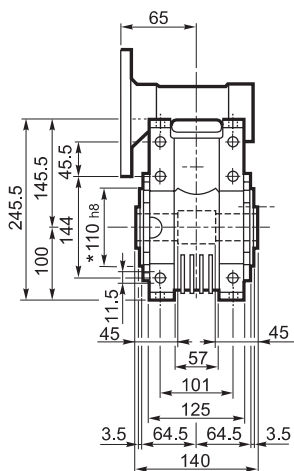

INPUT

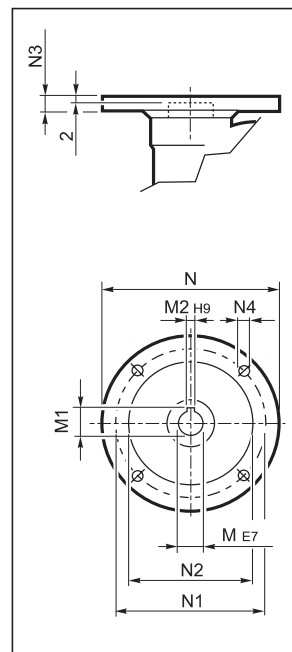

UF_

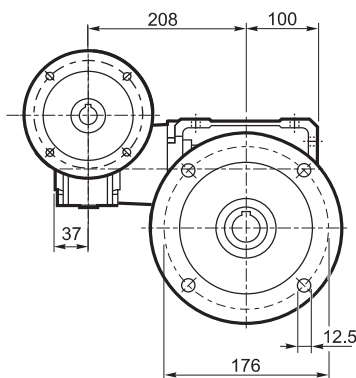
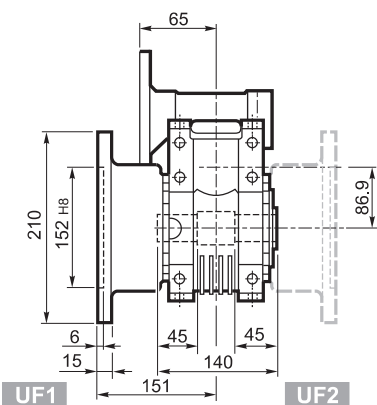

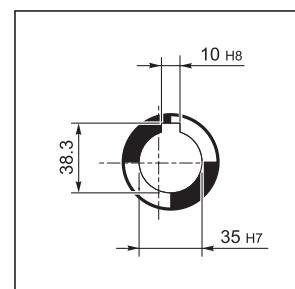

OUTPUT

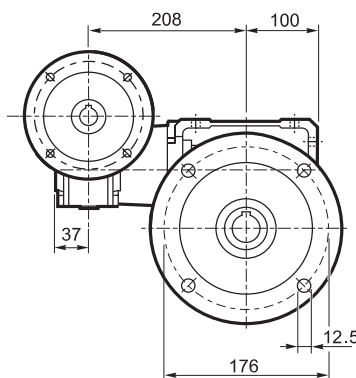
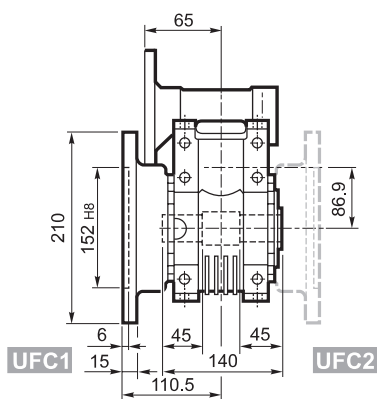

UFC_



		M	M1	M2	N	N1	N2	N3	N4	
VF/W 44/86	P63 B5	11	12.8	4	140	115	95	10	9.5	16.6
VF/W 44/86	P71 B5	14	16.3	5	160	130	110	10	9.5	
VF/W 44/86	P63 B14	11	12.8	4	90	75	60	8	5.5	
VF/W 44/86	P71 B14	14	16.3	5	105	85	70	10	7	

* De ambos lados



W 110...M

U

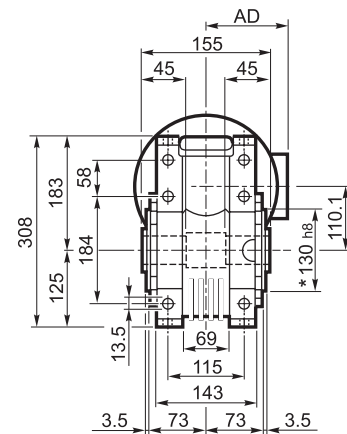
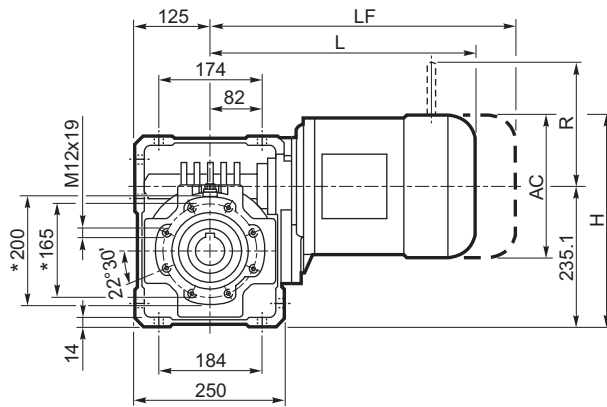

UF_

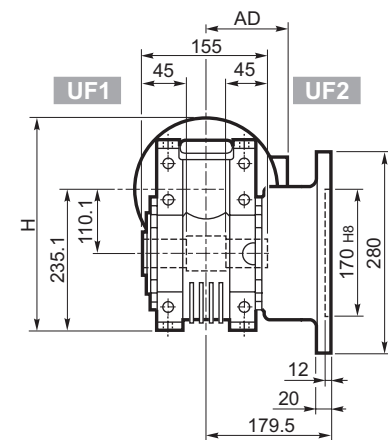
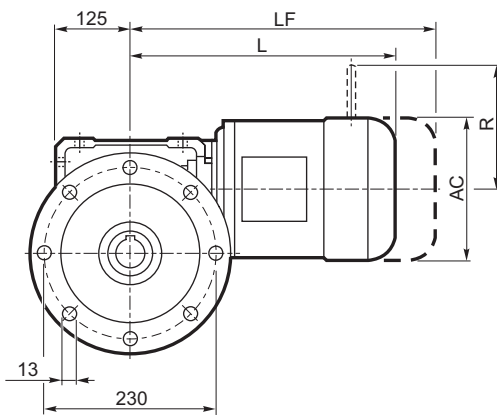

UFC_

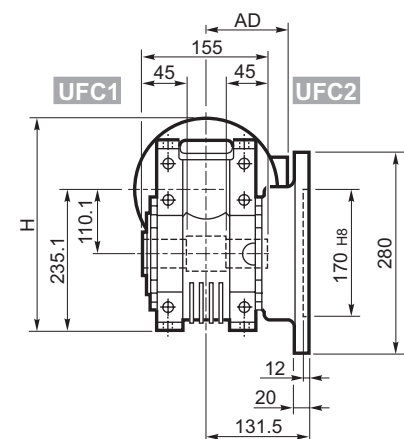
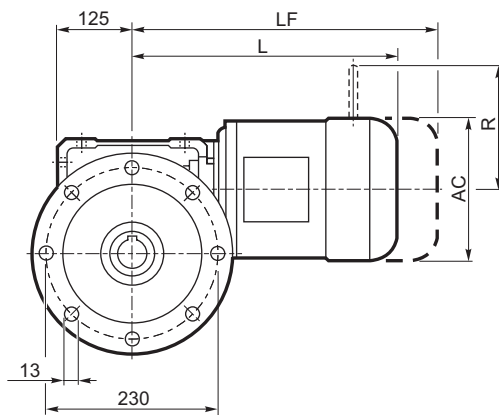

OUTPUT

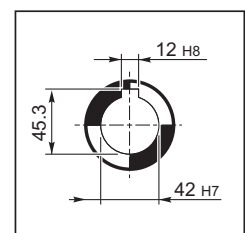

			M_				Kg	M...FD M...FA		Kg	M...FD		M...FA			
			AC	H	L	AD		LF	R		AD	R	AD			
			W 110	S2	M2S	156	313	364	119	38	440	41	129	146	134	119
W 110	S3	M3S	193	332	407	142	46	503	50	160	158	160	142			
W 110	S3	M3L	193	332	439	142	48	530	53	160	158	160	142			

* De ambos lados



W 110...P (IEC)

U

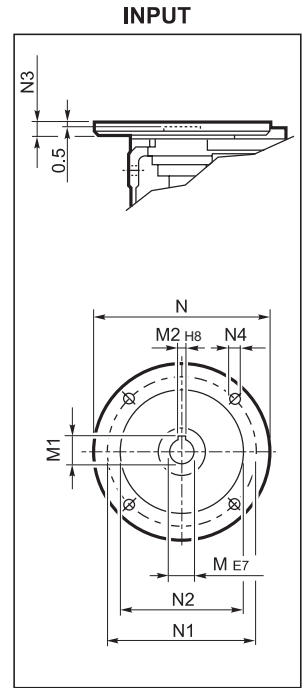
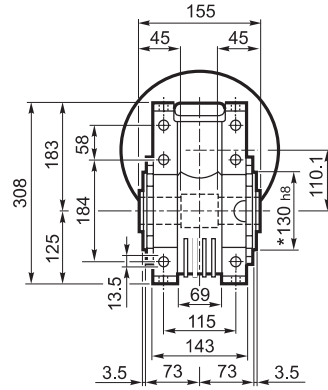
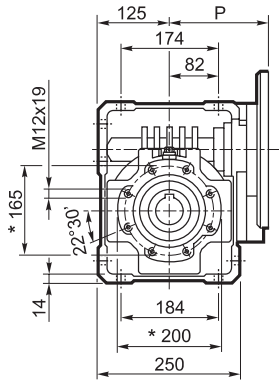

UF_

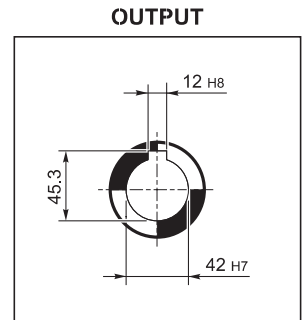
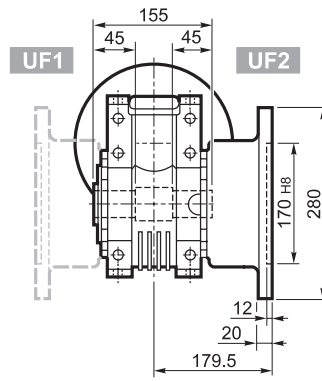
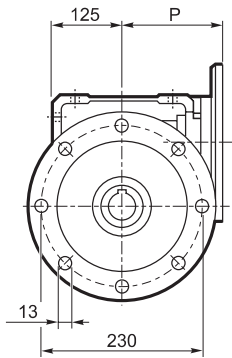

UFC_

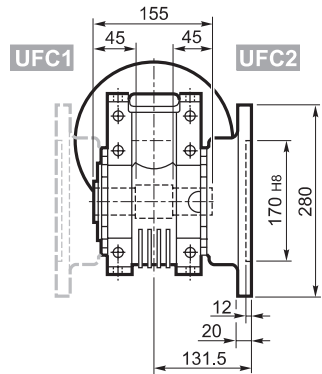
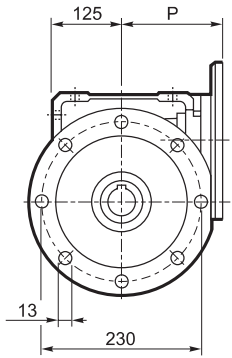

		M	M1	M2	N	N1	N2	N3	N4	P	
W 110	P80 B5	19	21.8	6	200	165	130	—	M10x12	143	28
W 110	P90 B5	24	27.3	8	200	165	130	—	M10x12	143	28
W 110	P100 B5	28	31.3	8	250	215	180	13	13	151	29
W 110	P112 B5	28	31.3	8	250	215	180	13	13	151	29
W 110	P132 B5	38	41.3	10	300	265	230	16	14	226	31
W 110	P80 B14	19	21.8	6	120	100	80	7.5	7	143	27.5
W 110	P90 B14	24	27.3	8	140	115	95	6.5	9	143	27.5
W 110	P100 B14	28	31.3	8	160	130	110	13	9	151	27
W 110	P112 B14	28	31.3	8	160	130	110	13	9	151	27

* De ambos lados



WR 110...P (IEC)

U

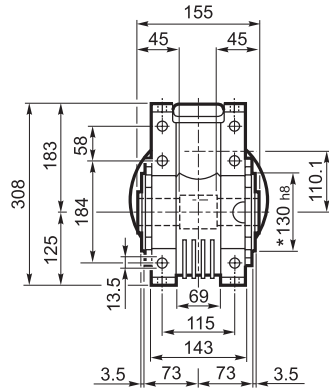
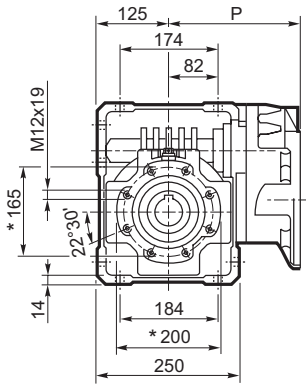

INPUT

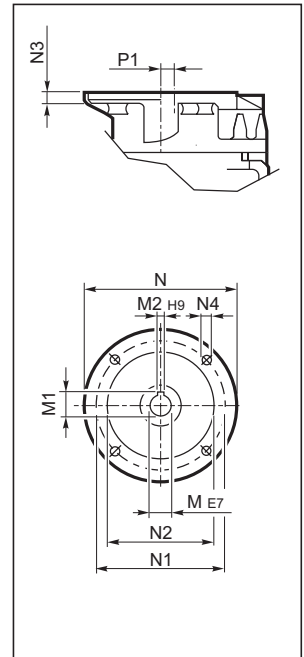

UF

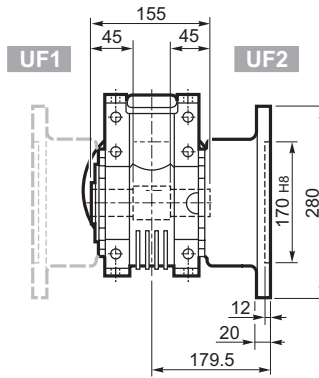
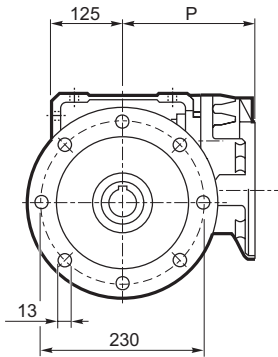

OUTPUT

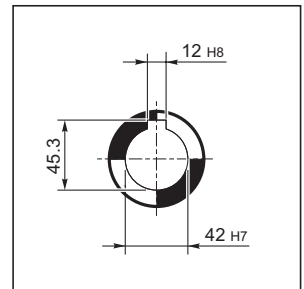

UFC

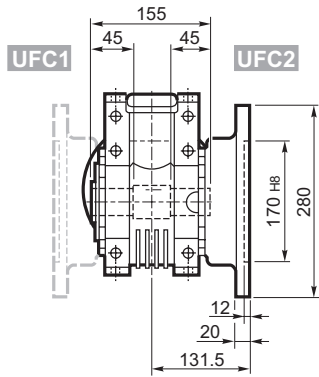
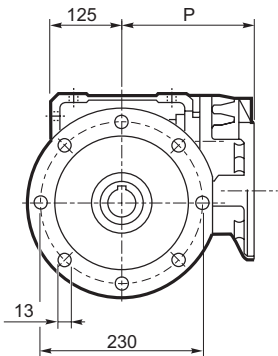

		M	M1	M2	N	N1	N2	N3	N4	P	P1	
WR 110	P71 B5	14	16.3	5	160	130	110	10	M8x14	185	58.6	30.5
WR 110	P80 B5	19	21.8	6	200	165	130	14	M10x15	204	21.1	31
WR 110	P90 B5	24	27.3	8	200	165	130	14	M10x15	204	21.1	31
WR 110	P100 B5	28	31.3	8	250	215	180	14	M12x13	213	21.1	32
WR 110	P112 B5	28	31.3	8	250	215	180	14	M12x13	213	21.1	32

* De ambos lados



VF/W 49/110...P (IEC)

U

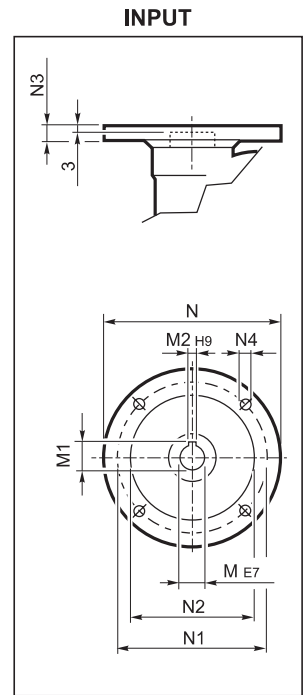
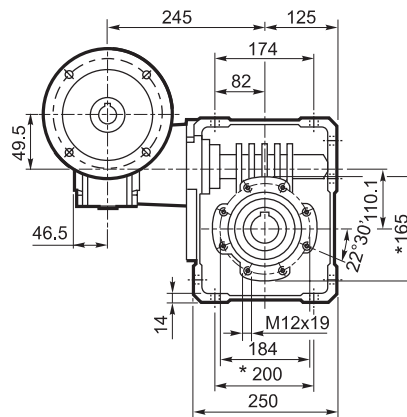
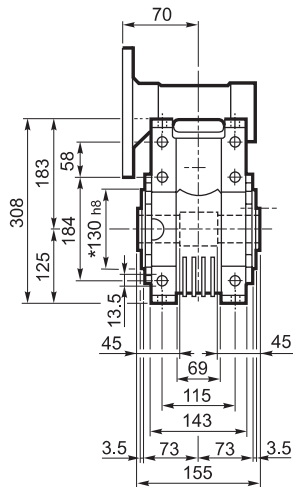

UF_

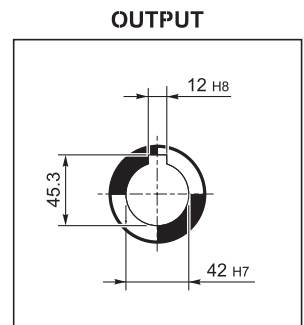
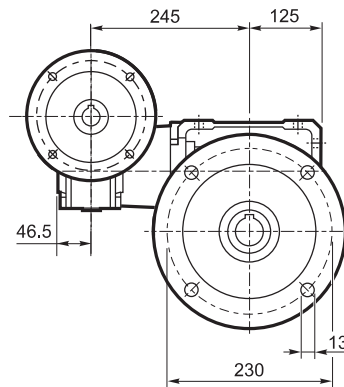
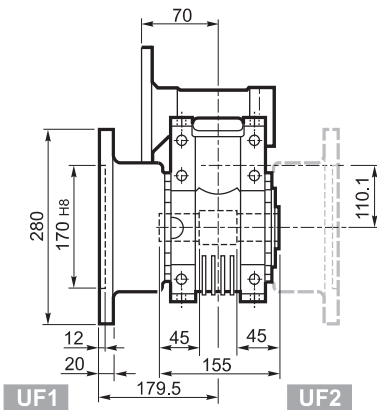

UFC_

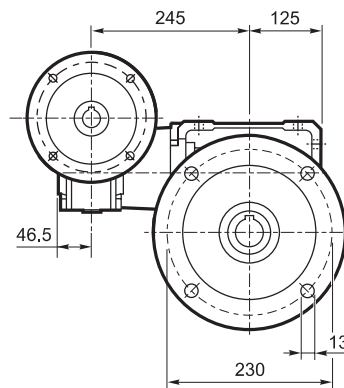
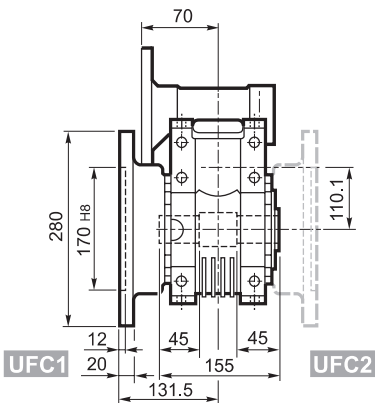

		M	M1	M2	N	N1	N2	N3	N4	
VF/W 49/110	P63 B5	11	12.8	4	140	115	95	10.5	9.5	33
VF/W 49/110	P71 B5	14	16.3	5	160	130	110	10.5	9.5	
VF/W 49/110	P80 B5	19	21.8	6	200	165	130	10	11.5	
VF/W 49/110	P63 B14	11	12.8	4	90	75	60	7	6	
VF/W 49/110	P71 B14	14	16.3	5	105	85	70	10.5	6.5	
VF/W 49/110	P80 B14	19	21.8	6	120	100	80	10	7	

* De ambos lados



VF 130...P (IEC)

A

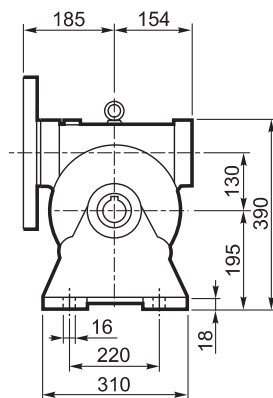
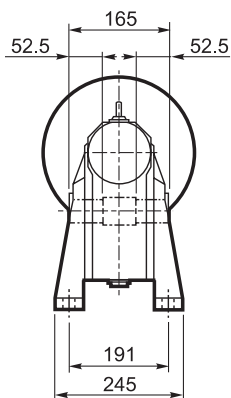

N

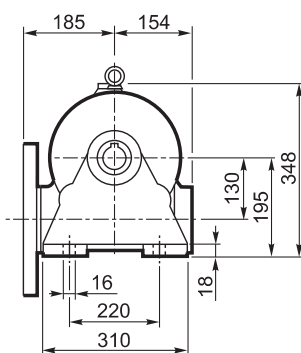
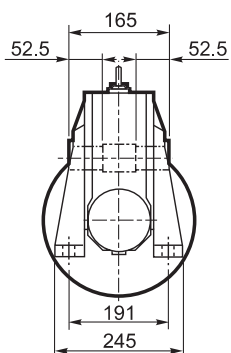

V

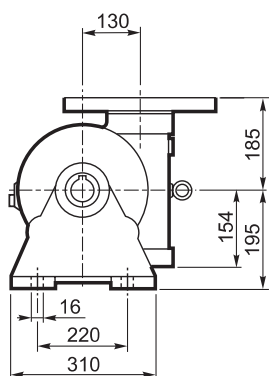
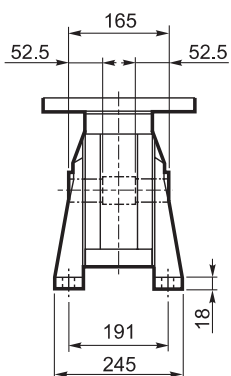

INPUT

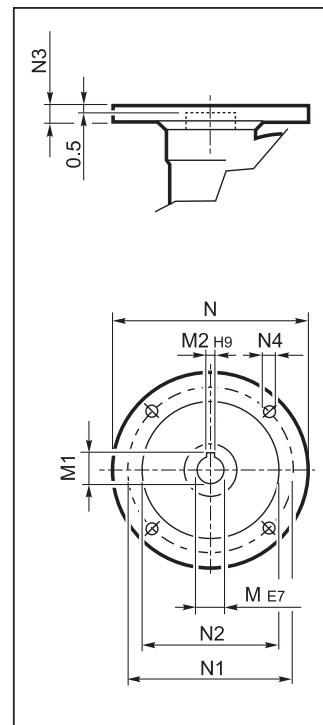

OUTPUT

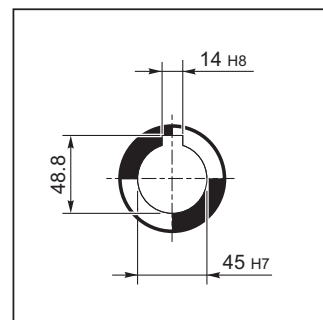



VF 130...P (IEC)

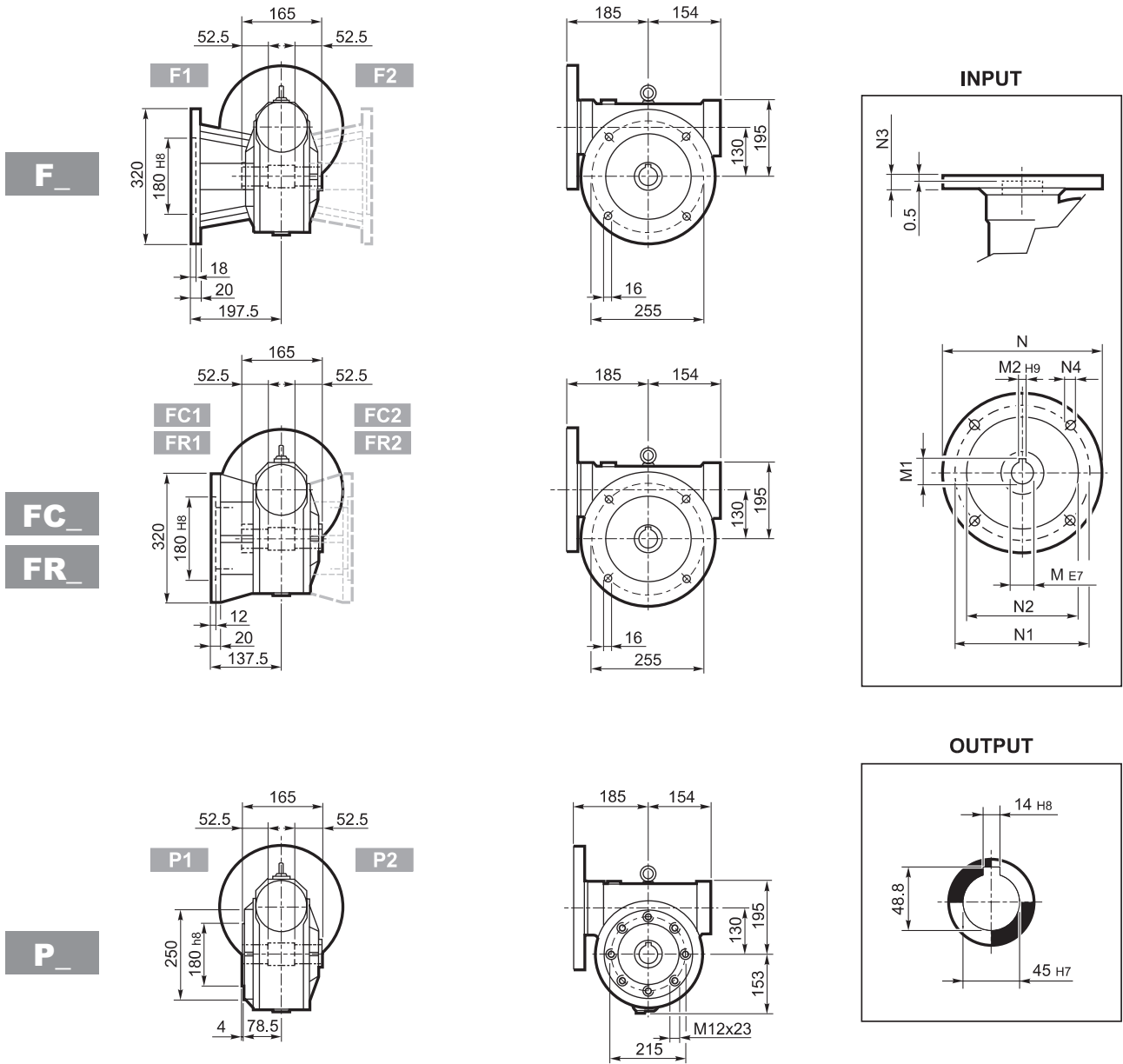

		M	M1	M2	N	N1	N2	N3	N4	
VF130	P90 B5	24	27.3	8	200	165	130	17	11	49
VF130	P100 B5	28	31.3	8	250	215	180	17	13	
VF130	P112 B5	28	31.3	8	250	215	180	17	13	
VF130	P132 B5	38	40.1#	10	300	265	230	17	13	

Brida reducida



VFR 130...P (IEC)

A

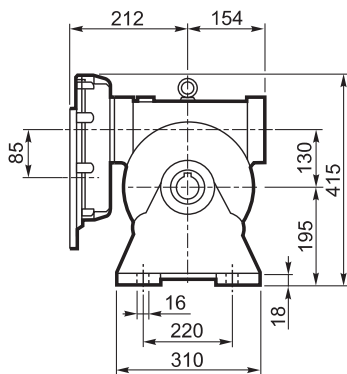
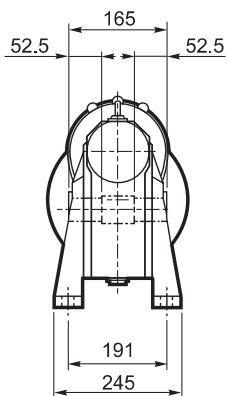

INPUT

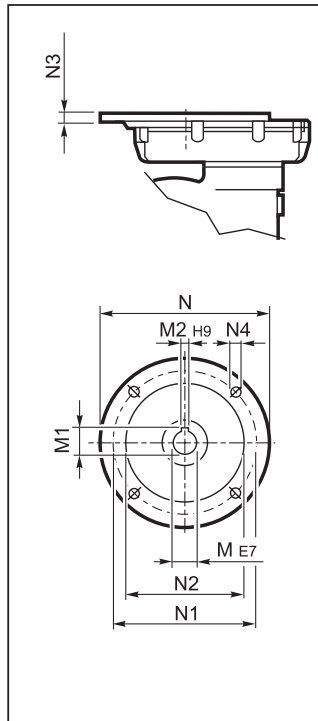

N

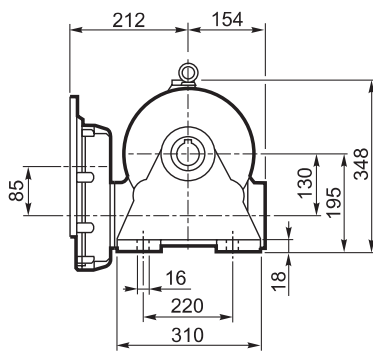
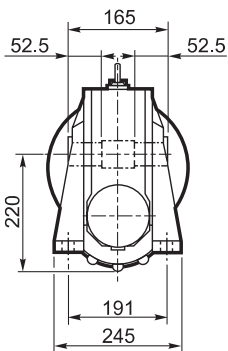

OUTPUT

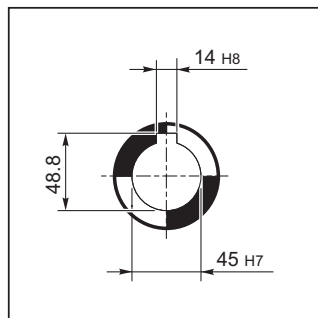

V

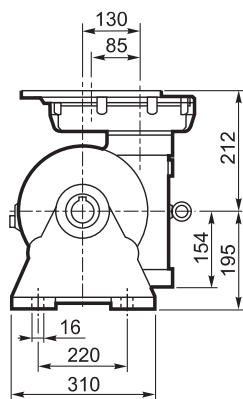
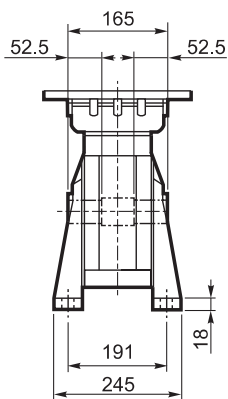



VFR 130...P (IEC)

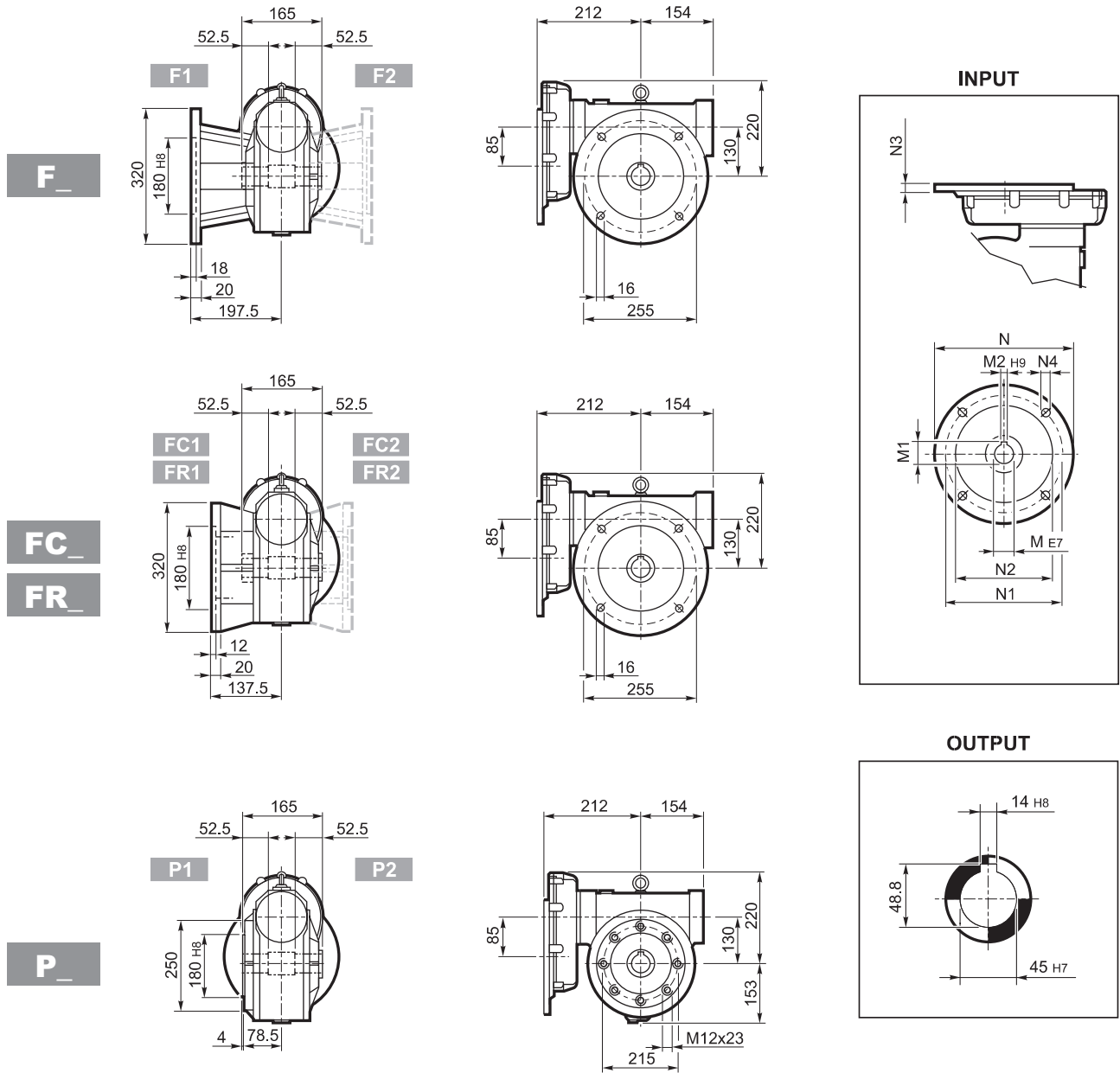

		M	M1	M2	N	N1	N2	N3	N4	
VFR 130	P80 B5	19 K6	21.8	6	200	165	130	12	M10x25	57
VFR 130	P90 B5	24 K6	27.3	8	200	165	130	12	M10x25	
VFR 130	P100 B5	28 J6	29.1#	8	250	215	180	13	M12x35	
VFR 130	P112 B5	28 J6	29.1#	8	250	215	180	13	M12x35	

Brida reducida



W/VF 63/130...M

A

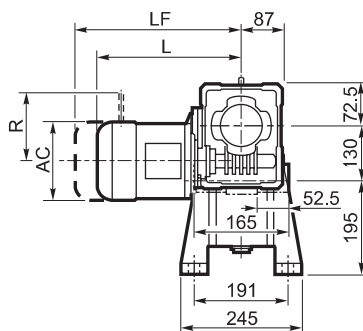
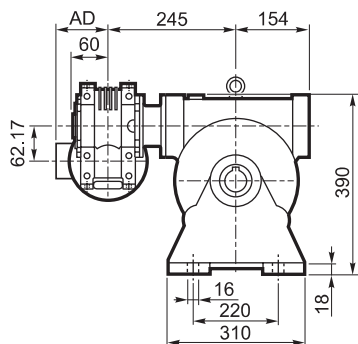

OUTPUT

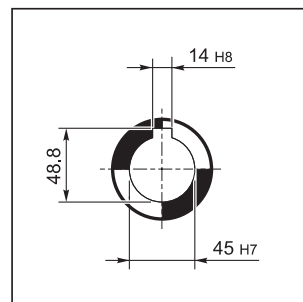

N

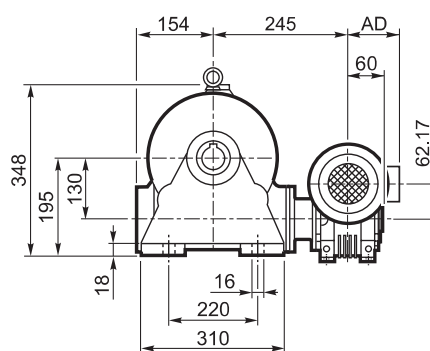
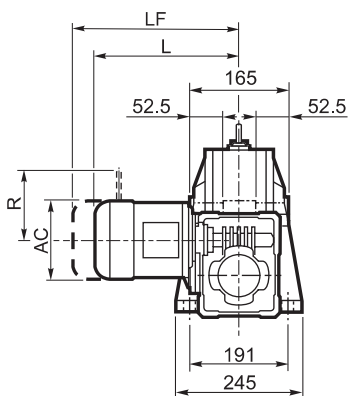

V

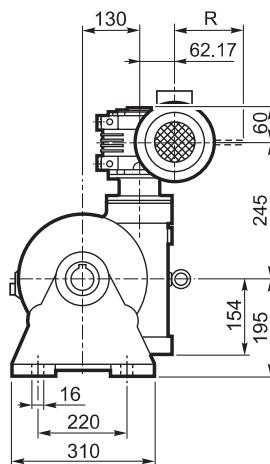
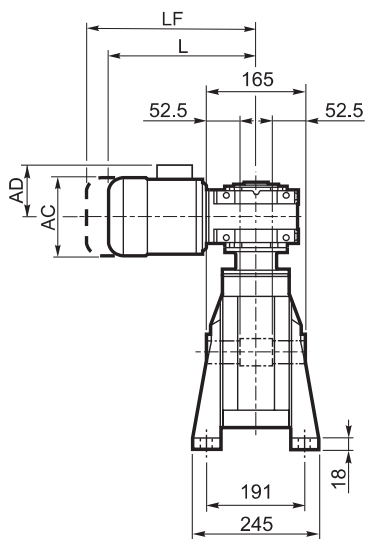



W/VF 63/130...M

F_
FC_
FR_

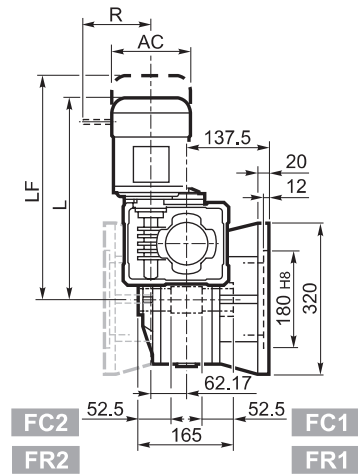
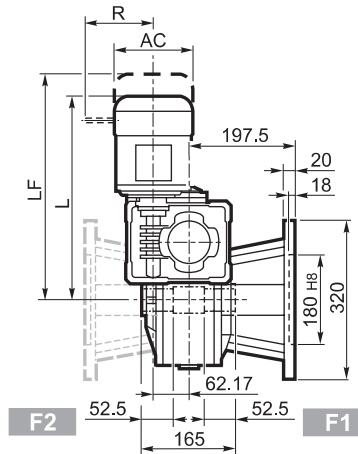
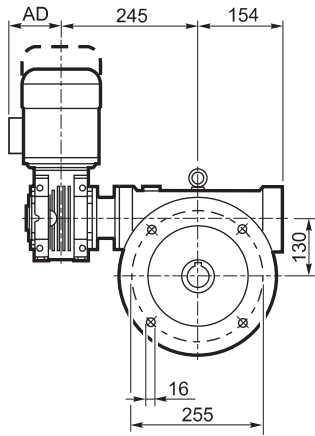

P_

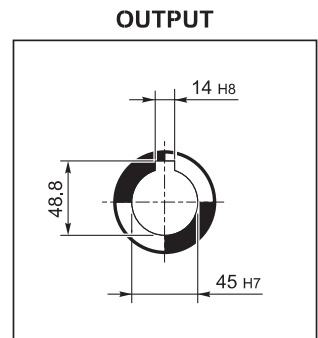
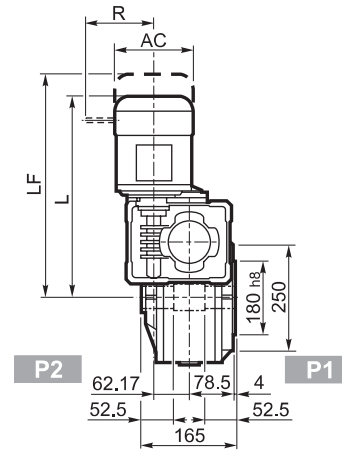
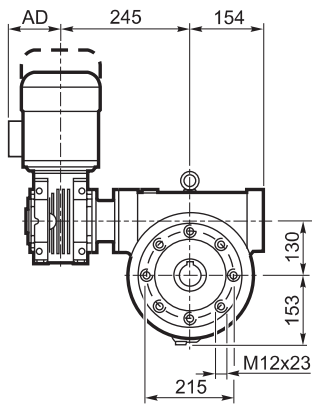

			M_				M...FD M...FA		M...FD		M...FA	
			AC	L	AD		LF		R	AD	R	AD
			138	419	108	63	480	65	103	135	124	108
W/VF 63/130	S1	M1	156	447	119	68	523	71	129	146	134	119



W/VF 63/130...P (IEC)

A

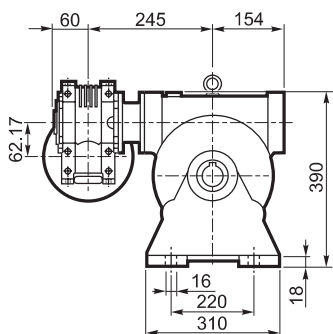

N

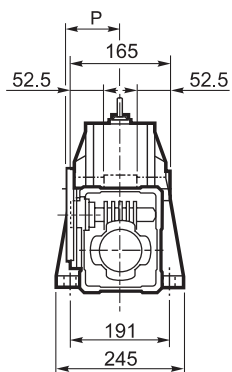

V

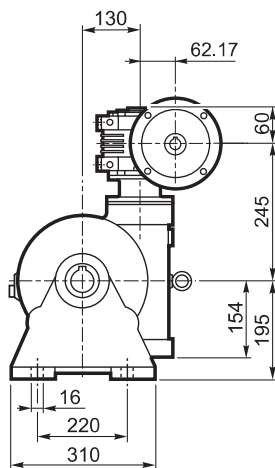
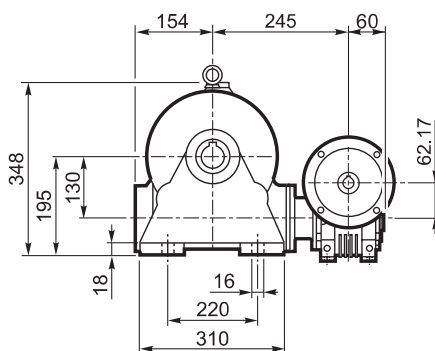
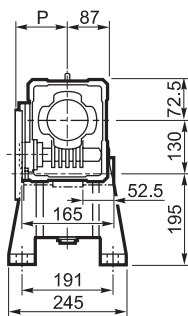
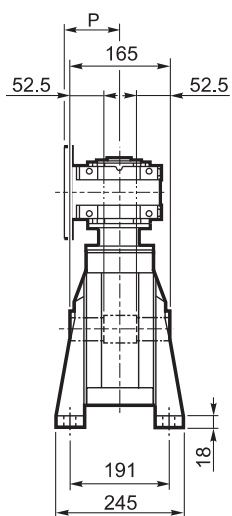

INPUT

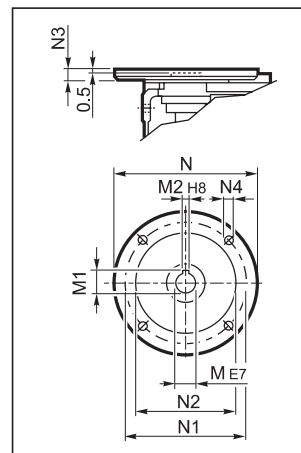

OUTPUT

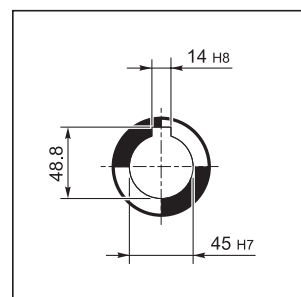



W/VF 63/130...P (IEC)

F_
FC_
FR_

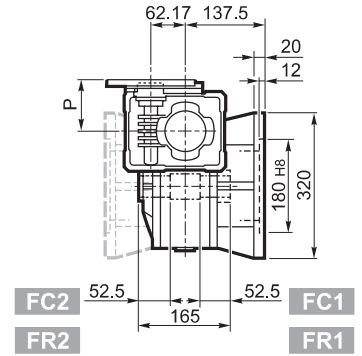
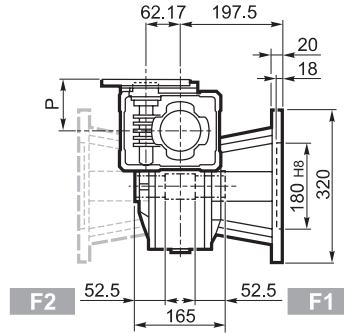
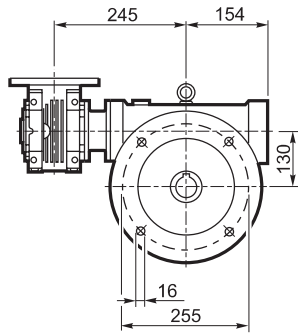

P_

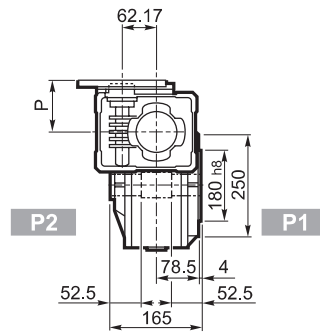
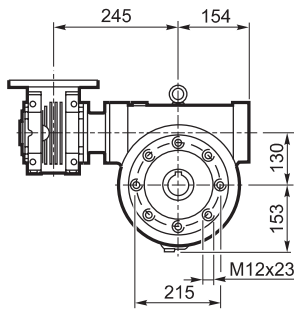

INPUT

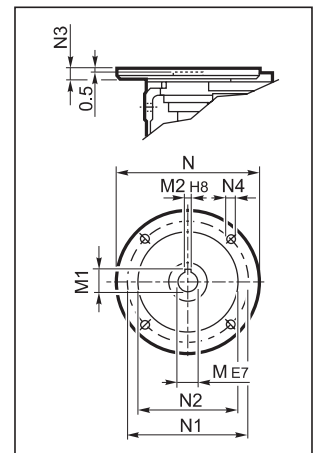

OUTPUT

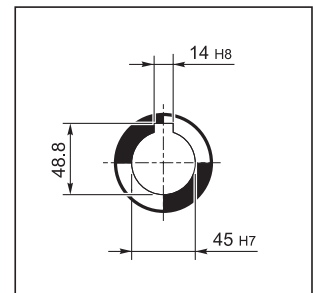

		M	M1	M2	N	N1	N2	N3	N4	P	Kg
W/VF 63/130	P71 B5	14	16.3	5	160	130	110	11	9	95	57
W/VF 63/130	P80 B5	19	21.8	6	200	165	130	12	11.5	102	
W/VF 63/130	P90 B5	24	27.3	8	200	165	130	12	11.5	102	
W/VF 63/130	P71 B14	14	16.3	5	105	85	70	11	6.5	95	
W/VF 63/130	P80 B14	19	21.8	6	120	100	80	11	6.5	102	
W/VF 63/130	P90 B14	24	27.3	8	140	115	95	11	8.5	102	



VF 150...P (IEC)

A

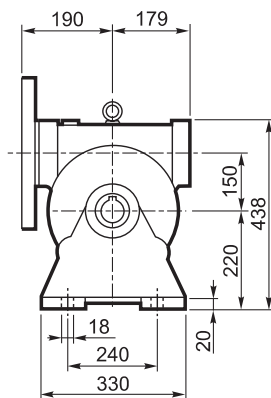
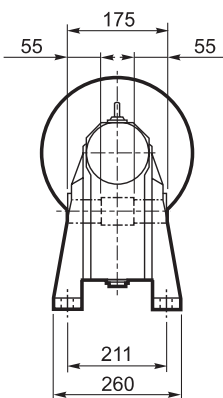

N

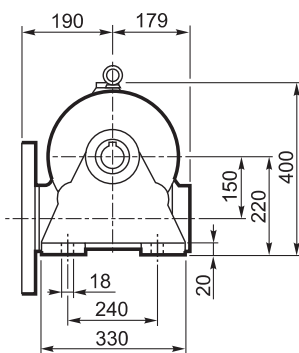
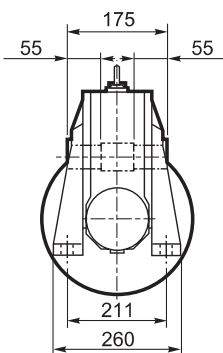

V

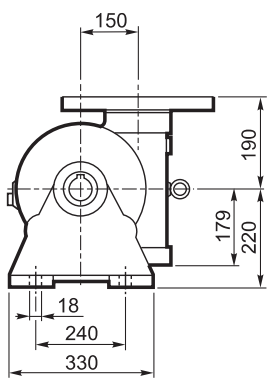
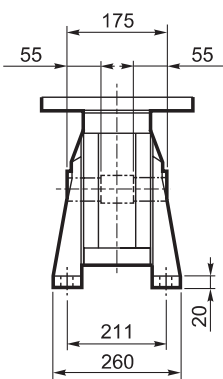

INPUT

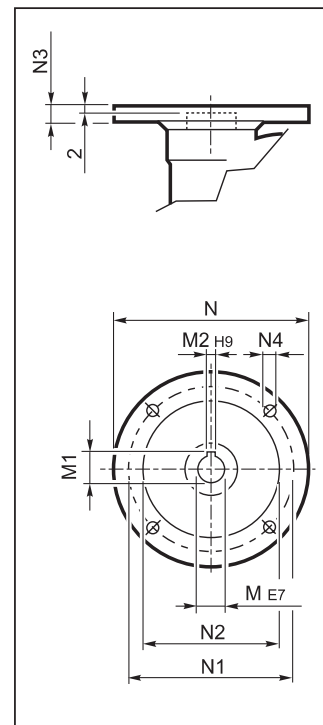



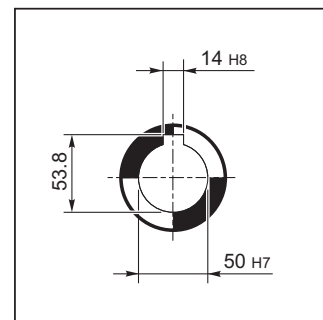

OUTPUT



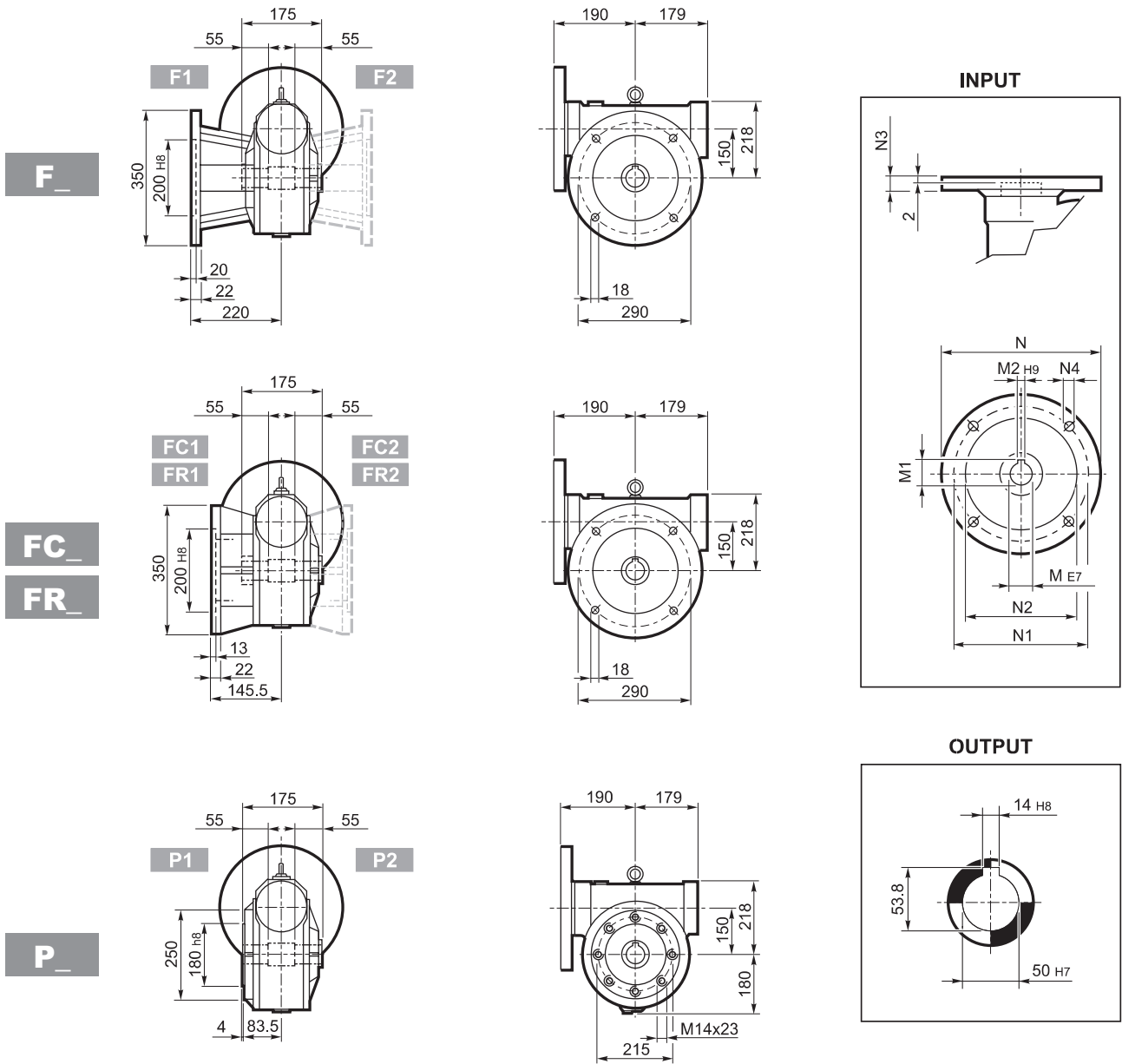

VF 150...P (IEC)



		M	M1	M2	N	N1	N2	N3	N4	 Kg
VF 150	P100 B5	28	31.3	8	250	215	180	11	13	60
VF 150	P112 B5	28	31.3	8	250	215	180	11	13	
VF 150	P132 B5	38	41.3	10	300	265	230	16	13	
VF 150	P160 B5	42	44.6#	12	350	300	250	18	18	

Brida reducida



VFR 150...P (IEC)

A

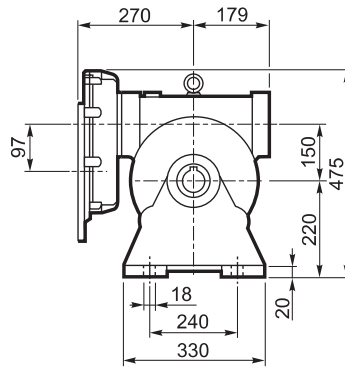
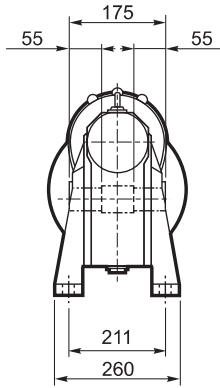

INPUT

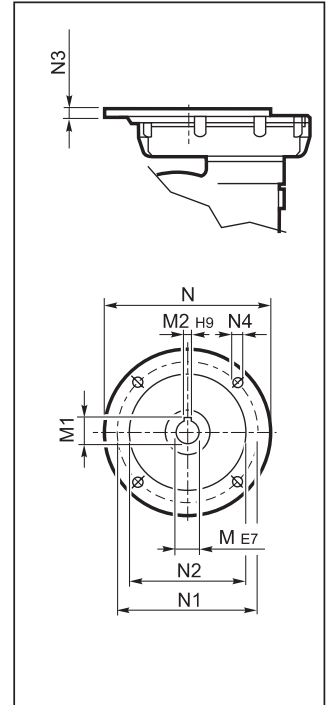

N

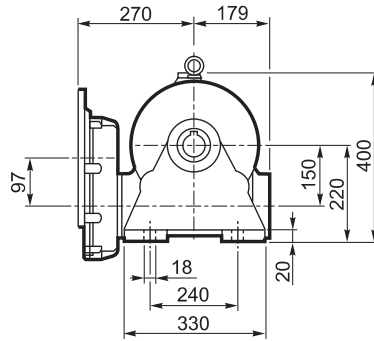
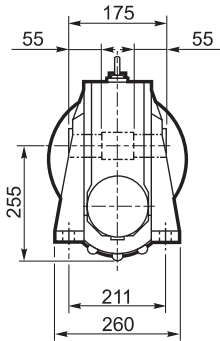

OUTPUT

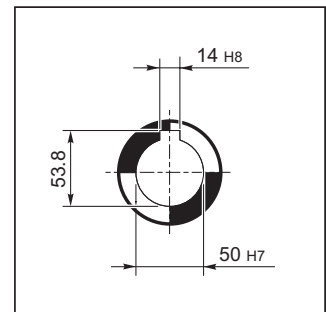

V

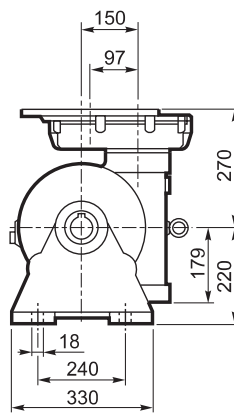
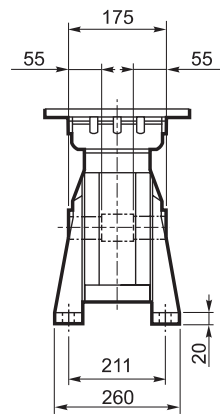



VFR 150...P (IEC)

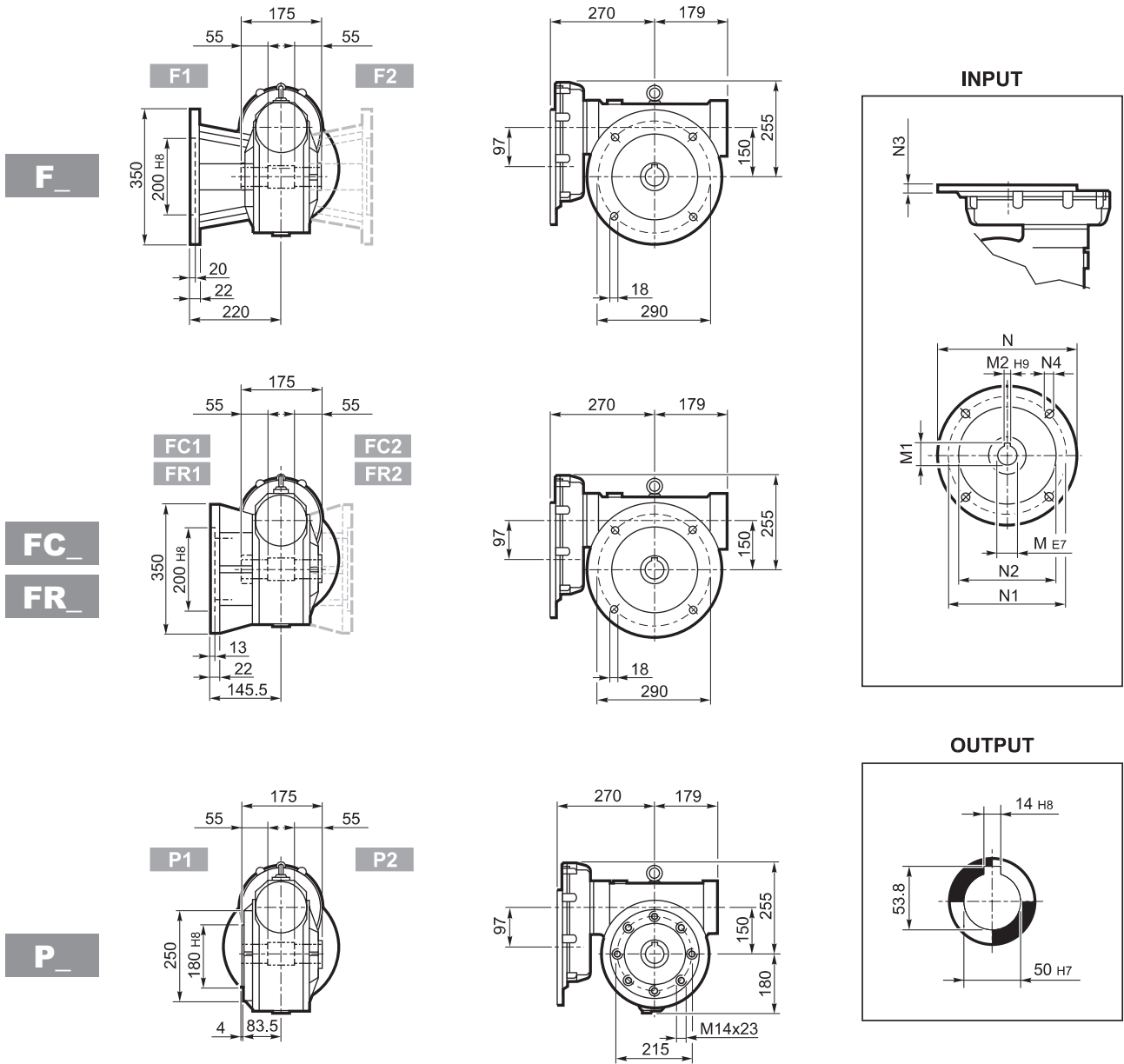

		M	M1	M2	N	N1	N2	N3	N4	
VFR 150	P90 B5	24 K6	27.3	8	200	165	130	13	M10x25	71
VFR 150	P100 B5	28 K6	31.3	8	250	215	180	13	M12x35	
VFR 150	P112 B5	28 J6	31.3	8	250	215	180	13	M12x35	
VFR 150	P132 B5	38 J6	39.6#	10	300	265	230	13	M12x35	

Brida reducida



W/VF 86/150...M

A

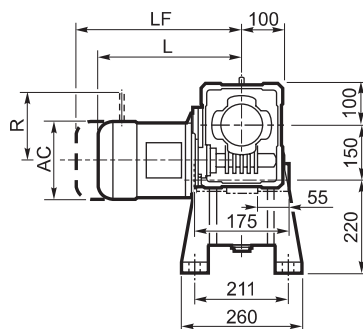
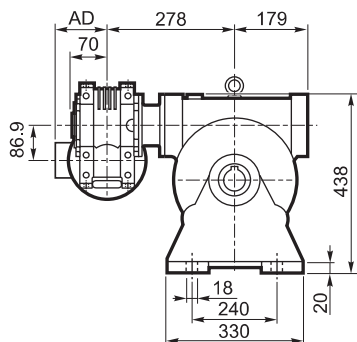

OUTPUT

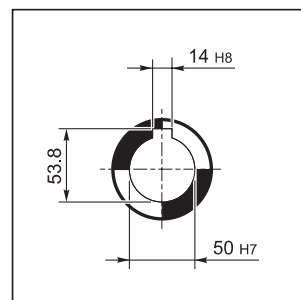

N

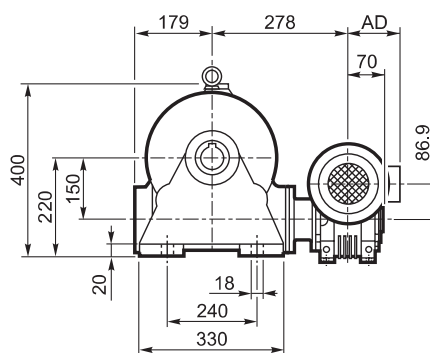
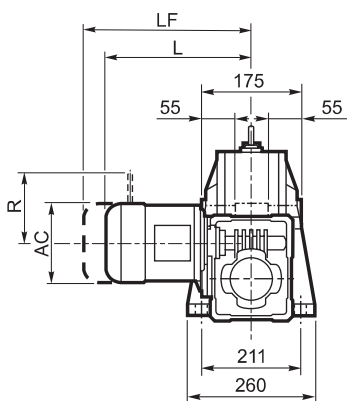

V

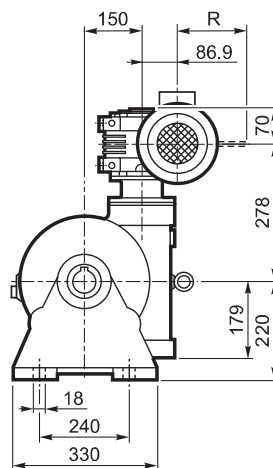
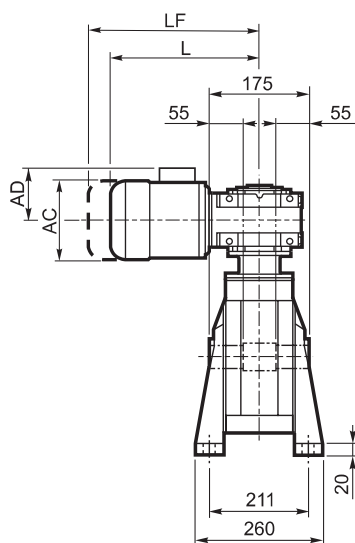



W/VF 86/150...M

F_
FC_
FR_

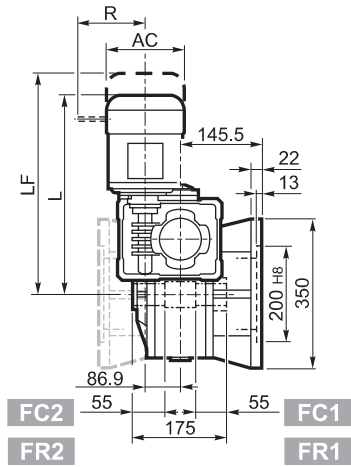
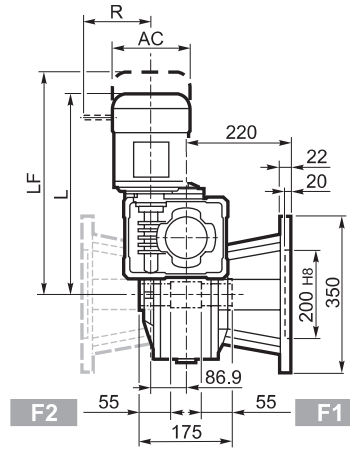
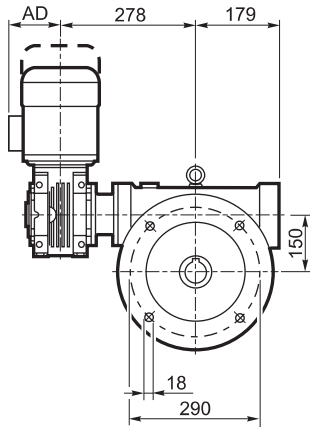

P_

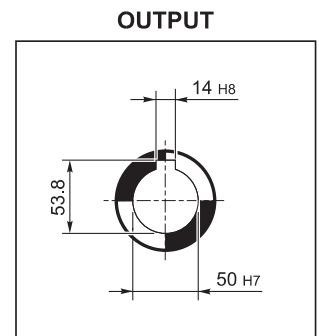
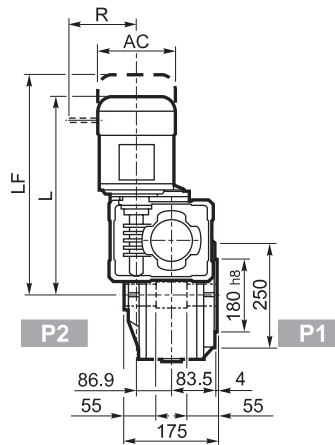
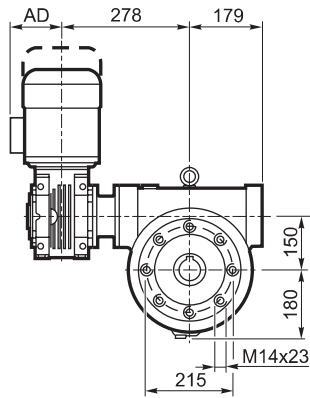

			M_				M...FD M...FA		M...FD		M...FA	
			AC	L	AD		LF		R	AD	R	AD
	S1	M1	138	474	108	82	385	84	103	135	124	108
	S2	M2S	156	499	119	86	425	89	129	146	134	119
	S3	M3S	193	542	142	91	488	97	160	158	160	142
	S3	M3L	193	574	142	99	515	104	160	158	160	142



W/VF 86/150...P (IEC)

A

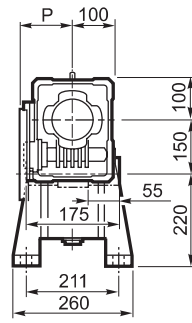
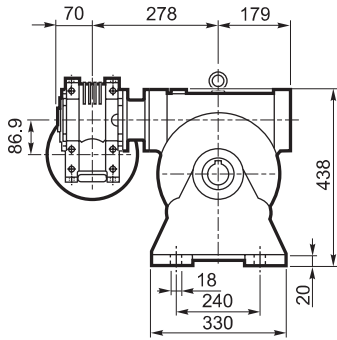

INPUT

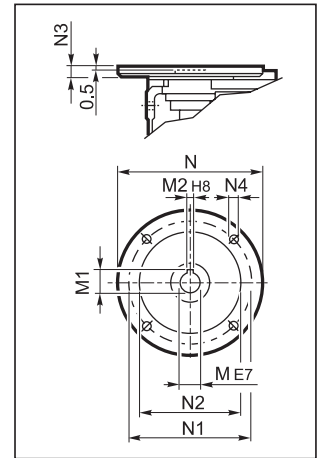

N

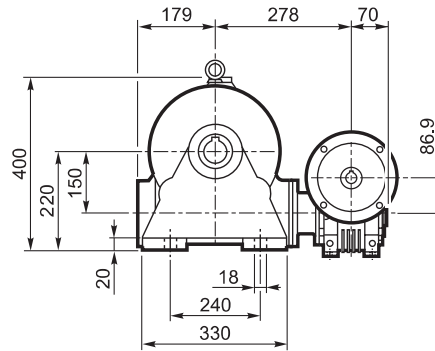
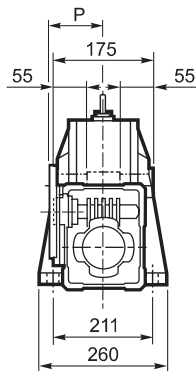

OUTPUT

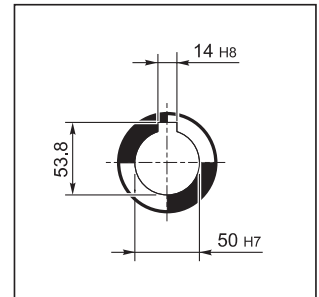

V

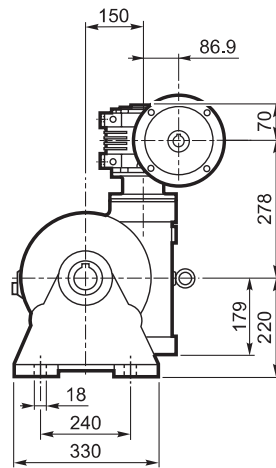
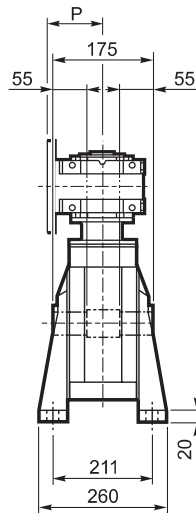



W/VF 86/150...P (IEC)

F
FC
FR

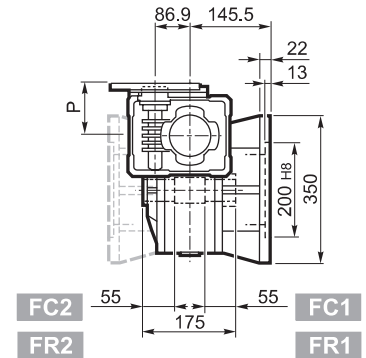
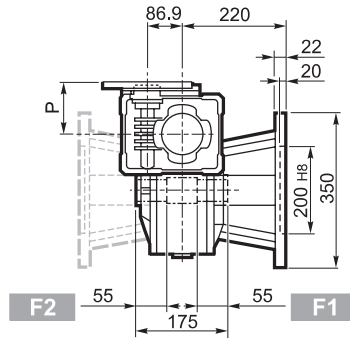
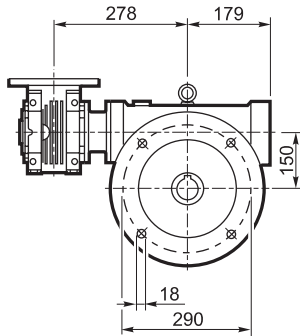

P

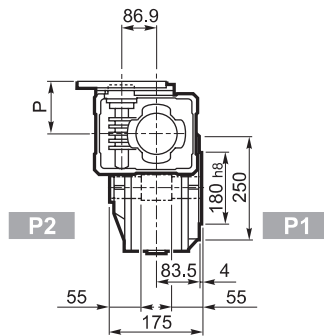
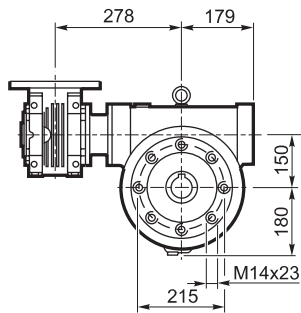

INPUT

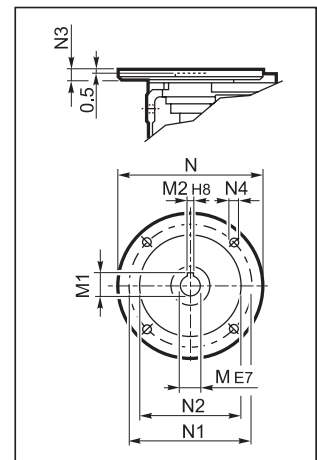

OUTPUT

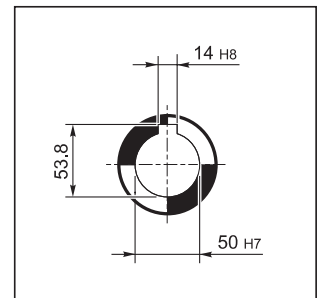

		M	M1	M2	N	N1	N2	N3	N4	P	
W/VF 86/150	P71 B5	14	16.3	5	160	130	110	11	9	128	75
W/VF 86/150	P80 B5	19	21.8	6	200	165	130	12	11.5	128	
W/VF 86/150	P90 B5	24	27.3	8	200	165	130	12	11.5	128	
W/VF 86/150	P100 B5	28	31.3	8	250	215	180	13	12.5	136	
W/VF 86/150	P112 B5	28	31.3	8	250	215	180	13	12.5	136	
W/VF 86/150	P80 B14	19	21.8	6	120	100	80	7.5	6.5	128	
W/VF 86/150	P90 B14	24	27.3	8	140	115	95	7.5	8.5	128	
W/VF 86/150	P100 B14	28	31.3	8	160	130	110	10	8.5	136	
W/VF 86/150	P112 B14	28	31.3	8	160	130	110	10	8.5	136	



VF 185...P (IEC)

A

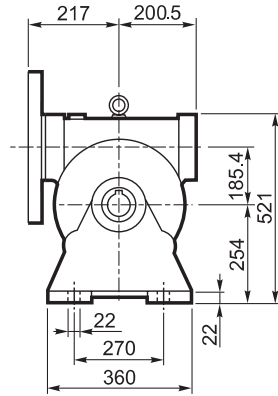
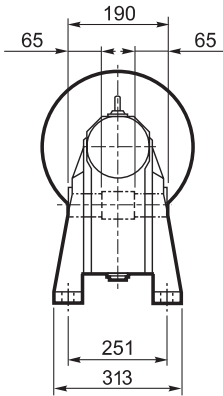

N

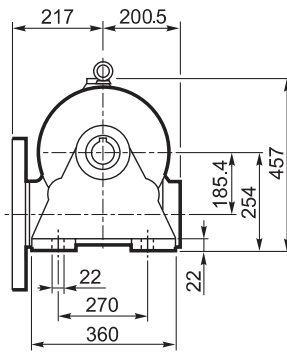
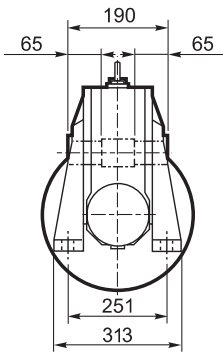

V

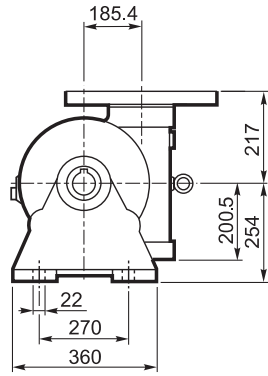
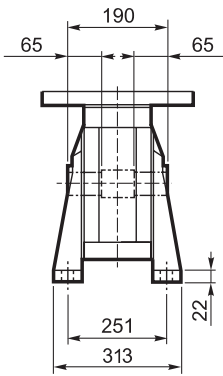

INPUT

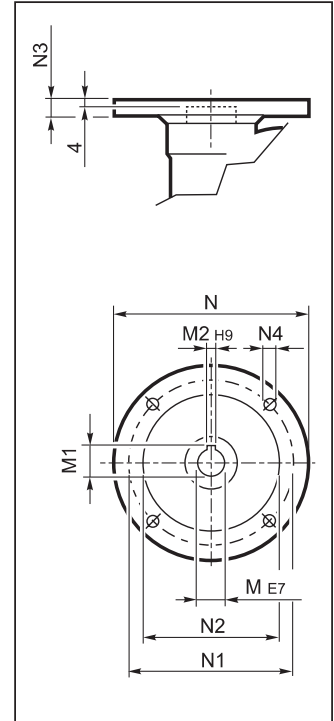

OUTPUT

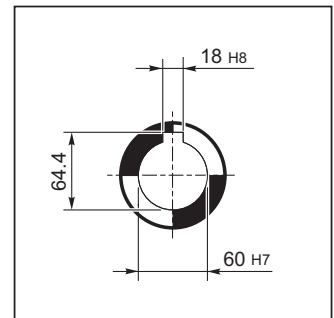

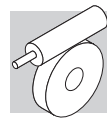

VF 185...P (IEC)

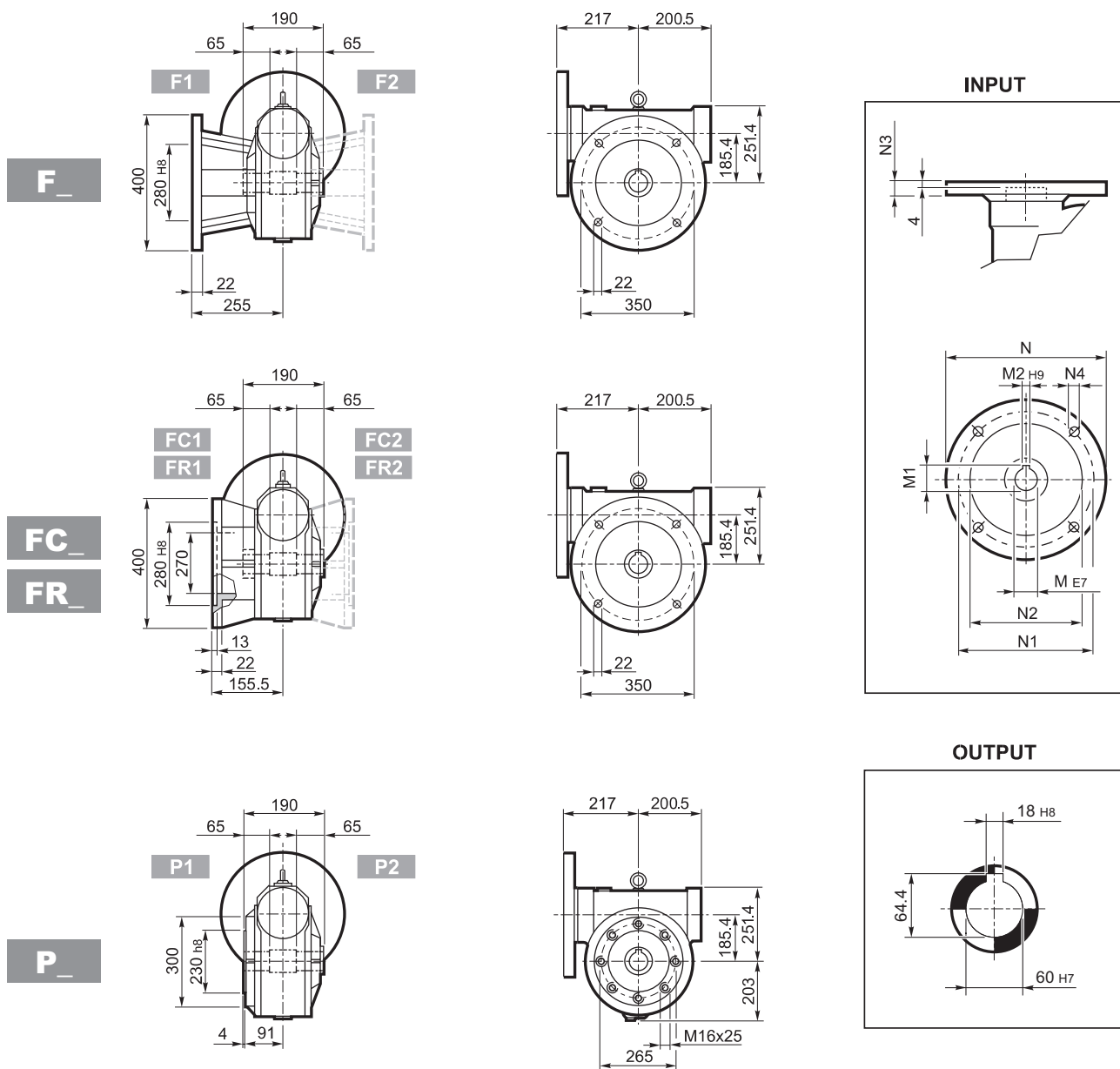

		M	M1	M2	N	N1	N2	N3	N4	
VF 185	P100 B5	28	31.3	8	250	215	180	16	13	94
VF 185	P112 B5	28	31.3	8	250	215	180	16	13	
VF 185	P132 B5	38	41.3	10	300	265	230	16	13	
VF 185	P160 B5	42	45.3	12	350	300	250	18	18	
VF 185	P180 B5	48	51.2#	14	350	300	250	18	18	

Brida reducida



VFR 185...P (IEC)

A

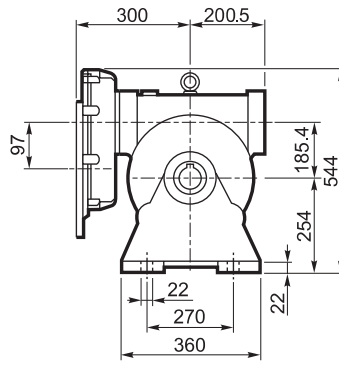
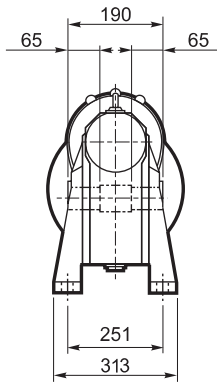

INPUT

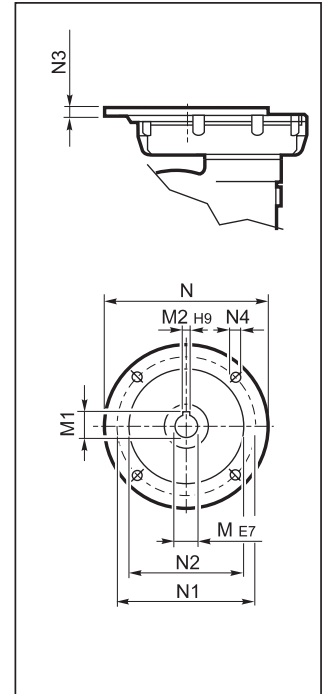

N

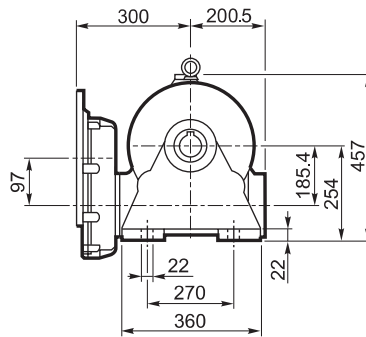
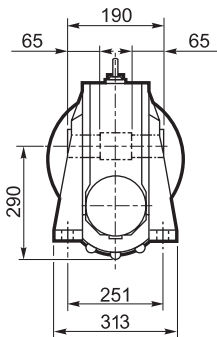

OUTPUT

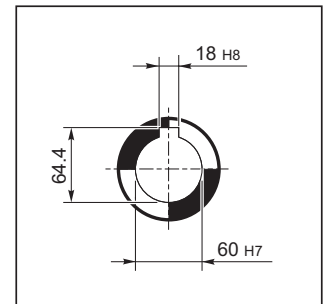

V

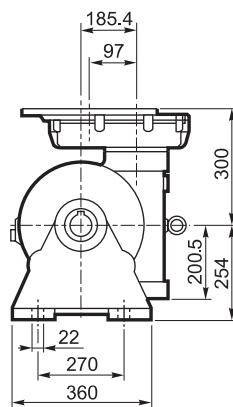
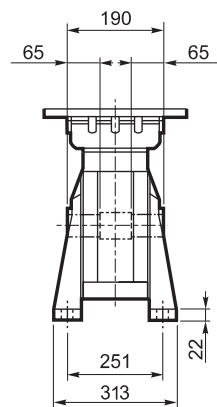

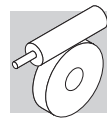

VFR 185...P (IEC)

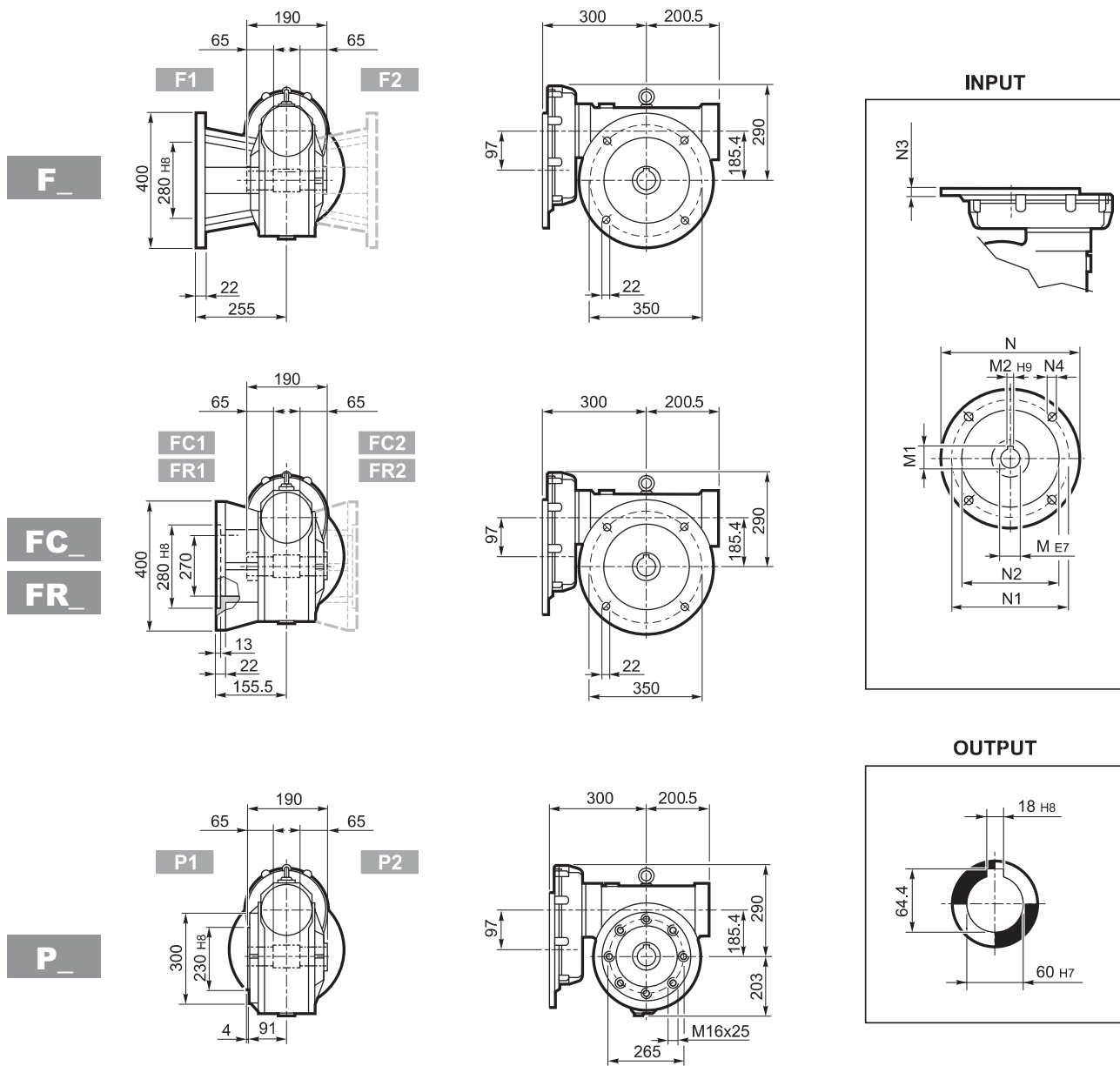

		M	M1	M2	N	N1	N2	N3	N4	
VFR 185	P90 B5	24 K6	27.3	8	200	165	130	13	M10x25	110
VFR 185	P100 B5	28 K6	31.3	8	250	215	180	13	M12x35	
VFR 185	P112 B5	28 K6	31.3	8	250	215	180	13	M12x35	
VFR 185	P132 B5	38 J6	39.6#	10	300	265	230	13	M12x35	

Brida reducida



W/VF 86/185...M

A

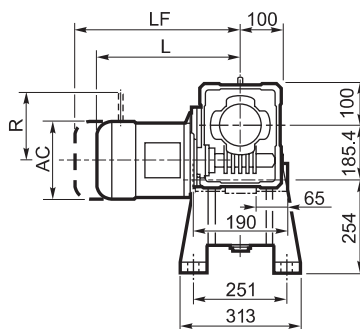
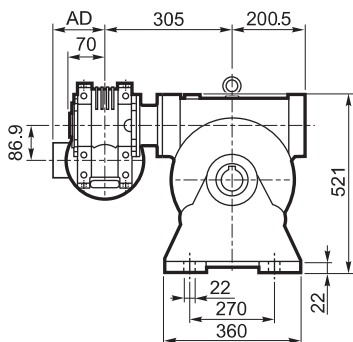

OUTPUT

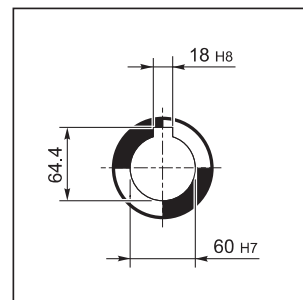

N

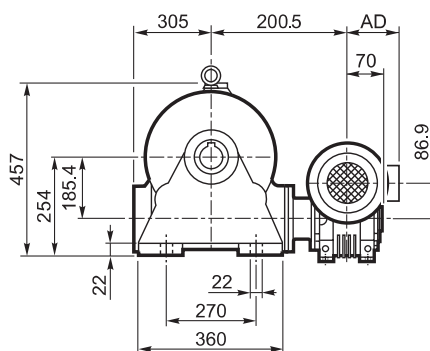
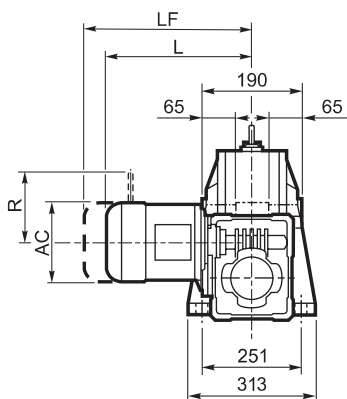

V

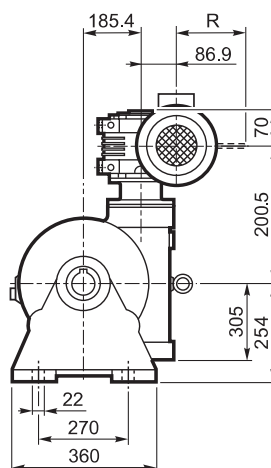
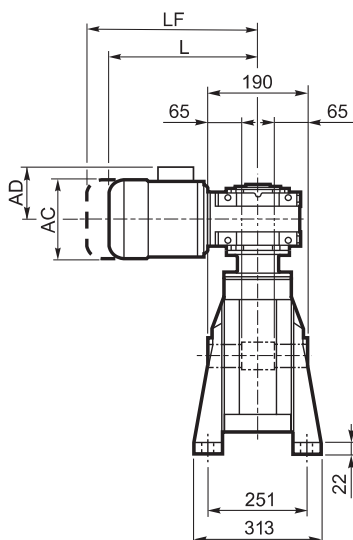

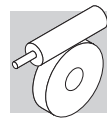

W/VF 86/185...M

F_
FC_
FR_

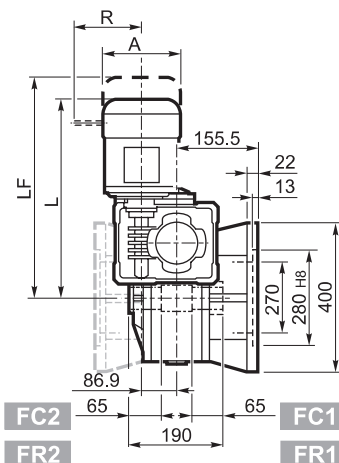
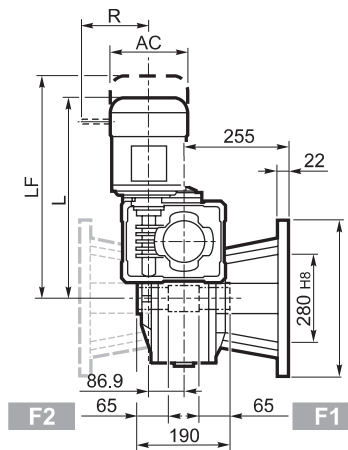
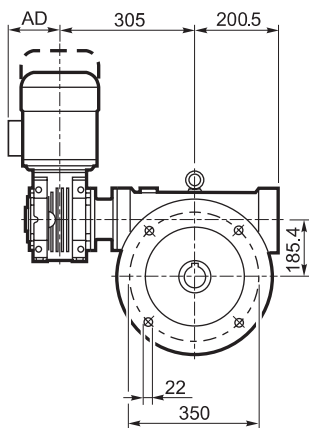

P_

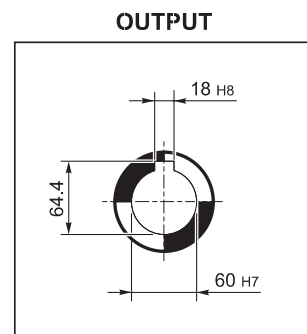
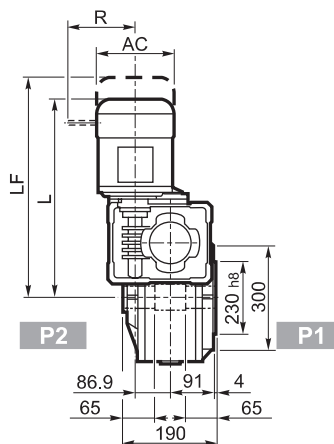
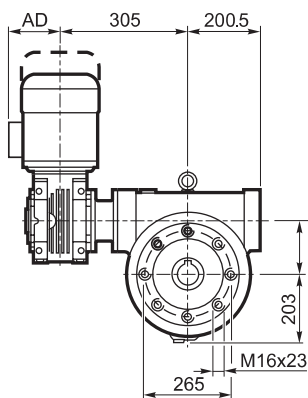

			M_				M...FD M...FA		M...FD		M...FA				
			AC	L	AD		LF		R	AD	R	AD			
			W/VF 86/185	S1	M1	138	509	108	116	570	118	103	135	124	108
			W/VF 86/185	S2	M2S	156	534	119	120	610	123	129	146	134	119
			W/VF 86/185	S3	M3S	193	577	142	125	673	131	160	158	160	142
			W/VF 86/185	S3	M3L	193	609	142	133	700	138	160	158	160	142



W/VF 86/185...P (IEC)

A

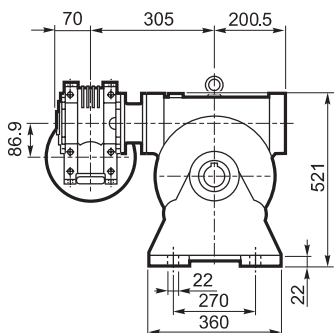

N

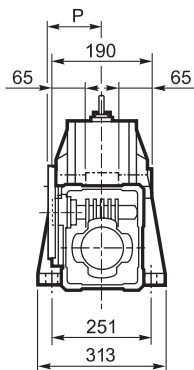

V

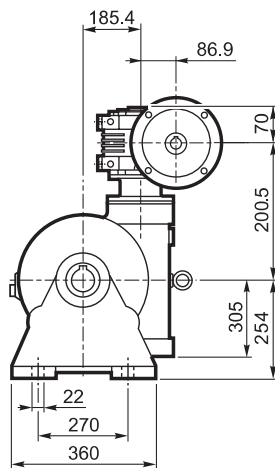
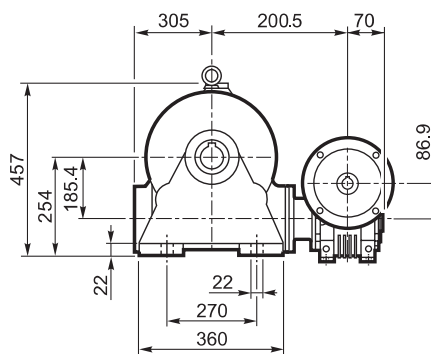
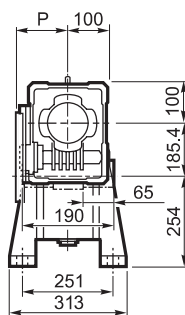
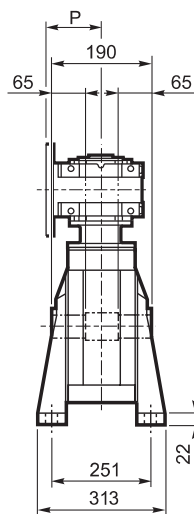

INPUT

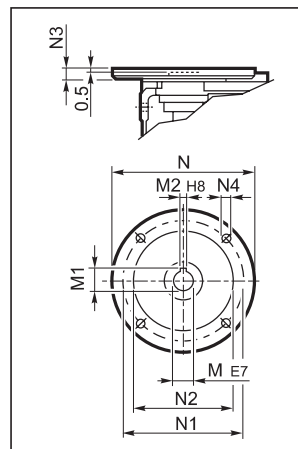

OUTPUT

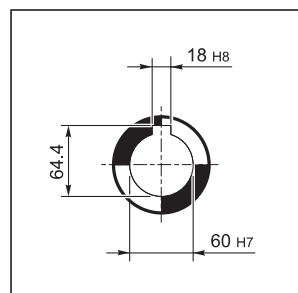



W/VF 86/185...P (IEC)

F_
FC_
FR_

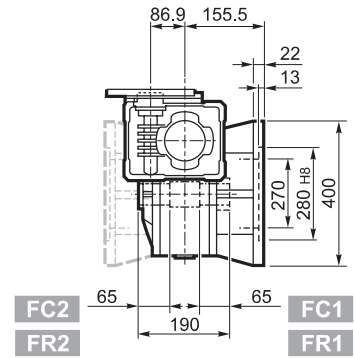
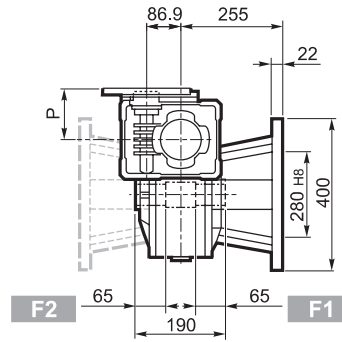
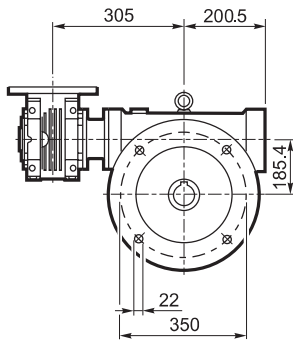

P_

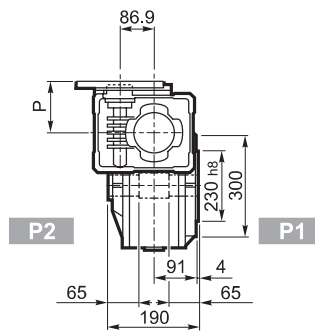
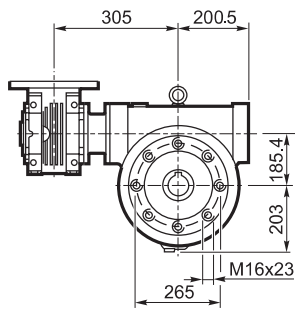

INPUT

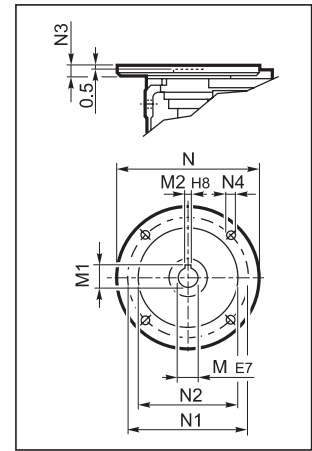

OUTPUT

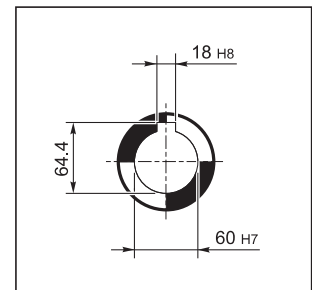

		M	M1	M2	N	N1	N2	N3	N4	P	
W/VF 86/185	P71 B5	14	16.3	5	160	130	110	11	9	128	109
W/VF 86/185	P80 B5	19	21.8	6	200	165	130	12	11.5	128	
W/VF 86/185	P90 B5	24	27.3	8	200	165	130	12	11.5	128	
W/VF 86/185	P100 B5	28	31.3	8	250	215	180	13	12.5	136	
W/VF 86/185	P112 B5	28	31.3	8	250	215	180	13	12.5	136	
W/VF 86/185	P80 B14	19	21.8	6	120	100	80	7.5	6.5	128	
W/VF 86/185	P90 B14	24	27.3	8	140	115	95	7.5	8.5	128	
W/VF 86/185	P100 B14	28	31.3	8	160	130	110	10	8.5	136	
W/VF 86/185	P112 B14	28	31.3	8	160	130	110	10	8.5	136	



VF 210...P (IEC)

A

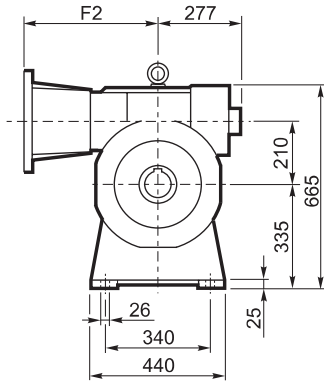
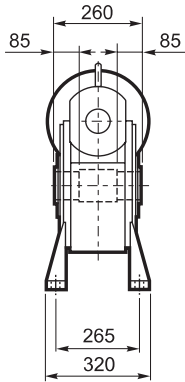

N

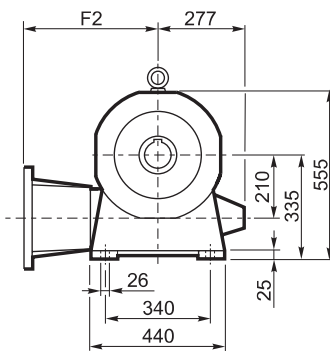
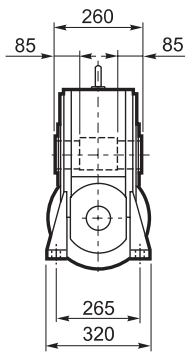

INPUT

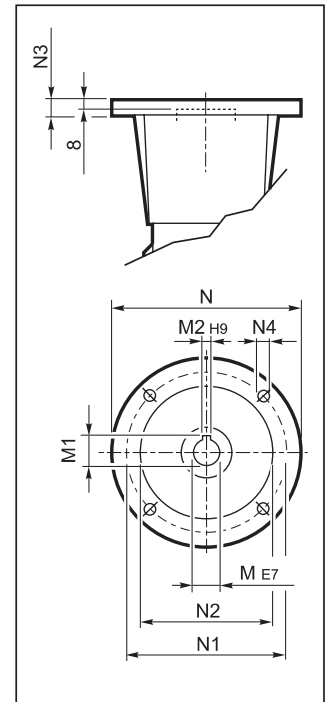

OUTPUT

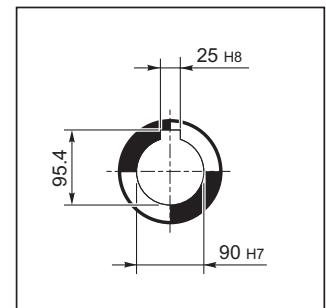



VF 210...P (IEC)

V

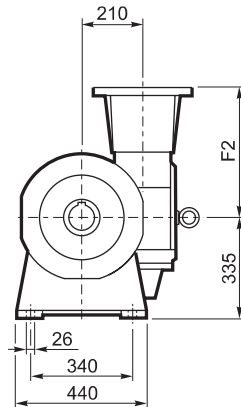
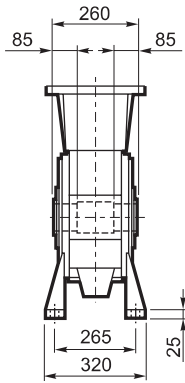

P

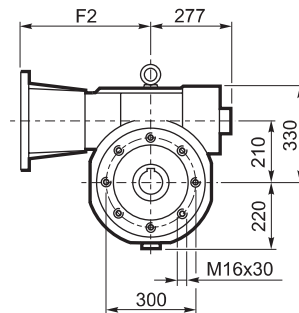
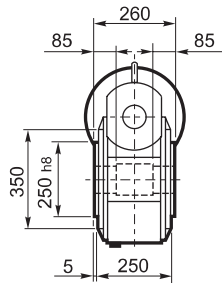

INPUT

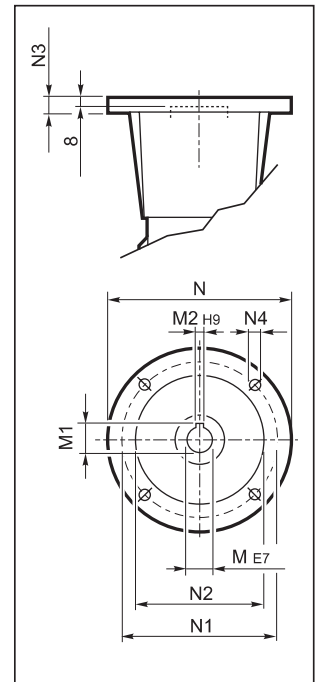

OUTPUT

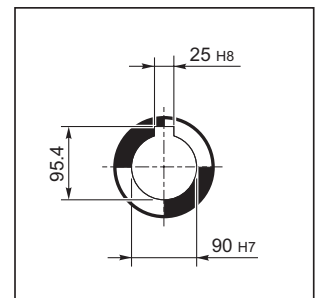

Las formas constructivas A y P llevan acoplado un ventilador de refrigeración.
En la ejecución P(IEC) en el suministro, incluye de serie, el acoplamiento completo para ataque motor.

		F2	M	M1	M2	N	N1	N2	N3	N4	
VF 210	P132 B5	485	38	41.3	10	300	265	230	25	M12	210
VF 210	P160 B5	460	42	45.3	12	350	300	250	22	18	
VF 210	P180 B5	460	48	51.8	14	350	300	250	22	18	
VF 210	P200 B5	485	55	59.3	16	400	350	300	25	M16	
VF 210	P225 B5	490	60	64.4	18	450	400	350	22	18 #	

N. 8 agujeros 45°



VFR 210...P (IEC)

A

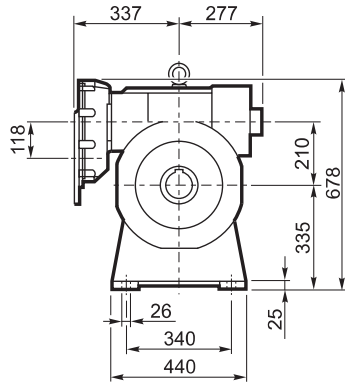
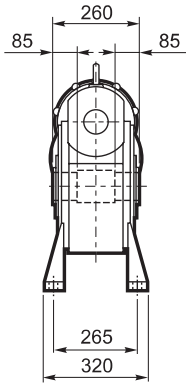

N

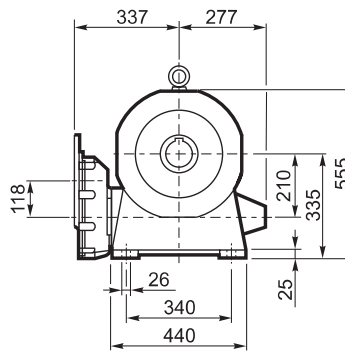
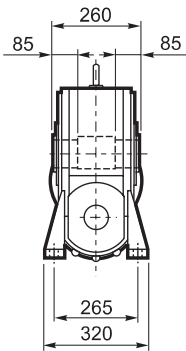

INPUT

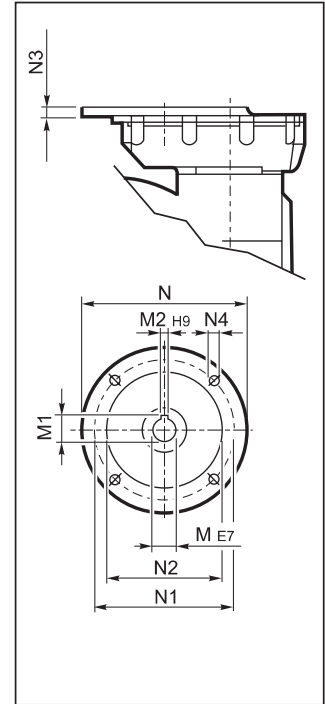

OUTPUT

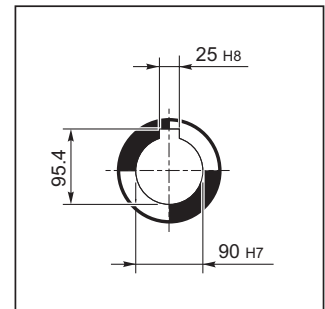



VFR 210...P (IEC)

V

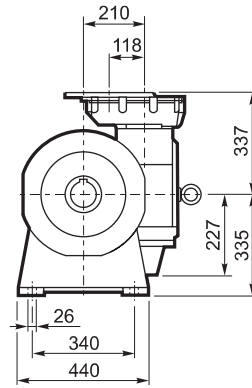
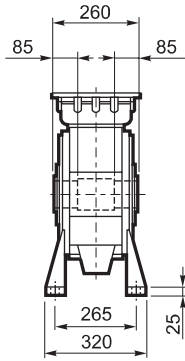

P

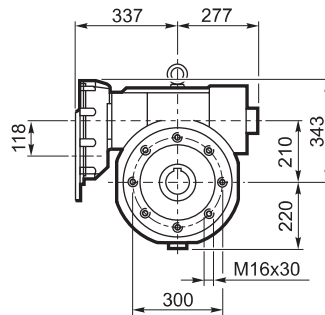
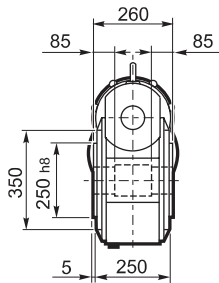

INPUT

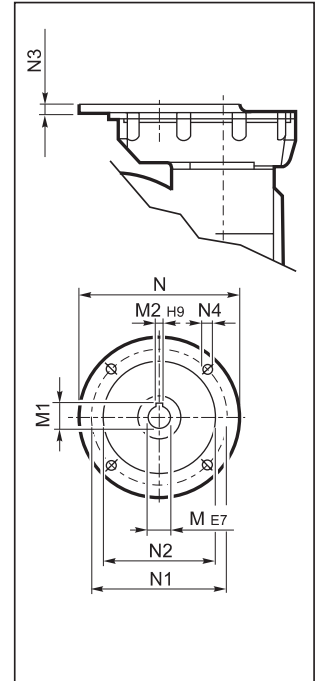

OUTPUT

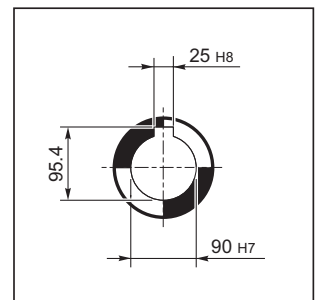

Las formas constructivas A y P llevan acoplado un ventilador de refrigeración.

		M	M1	M2	N	N1	N2	N3	N4	
VFR 210	P100 B5	28 K6	31.3	8	250	215	180	13	M12x35	185
VFR 210	P112 B5	28 K6	31.3	8	250	215	180	13	M12x35	
VFR 210	P132 B5	38 J6	41.3	10	300	265	230	13	M12x35	
VFR 210	P160 B5	42 J6	44.3#	12	350	300	250	18	M16x60	

Brida reducida



VF/VF 130/210...P (IEC)

A

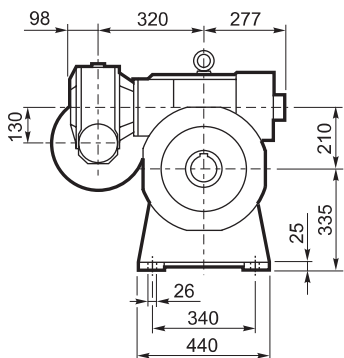

N

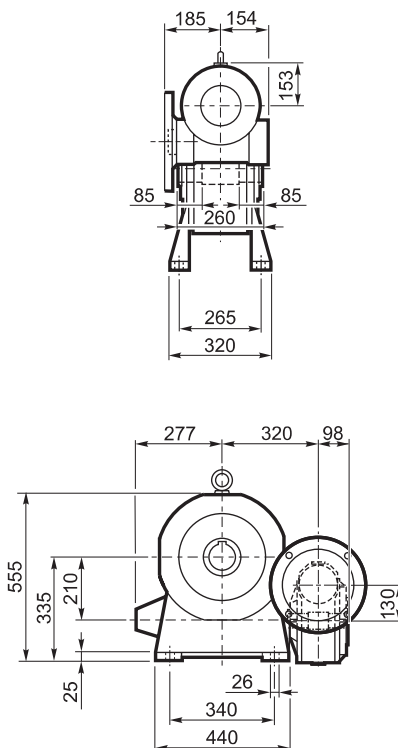
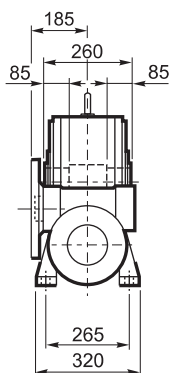

V

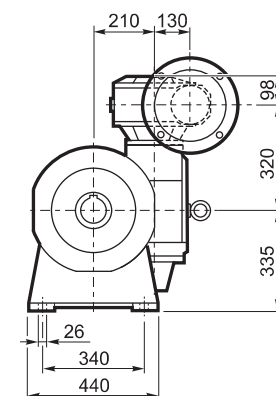
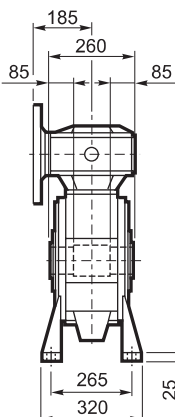

P

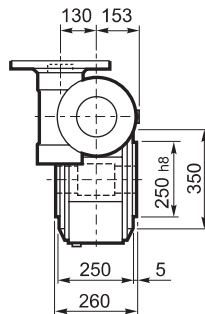
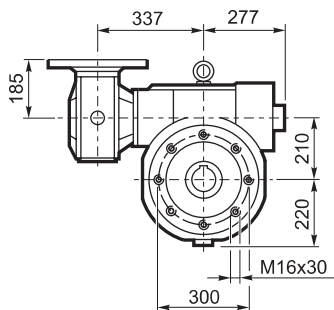

INPUT

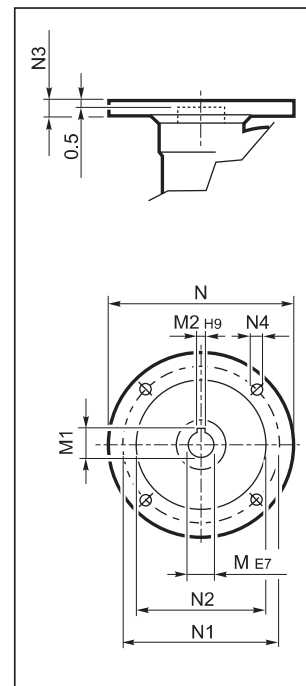

OUTPUT

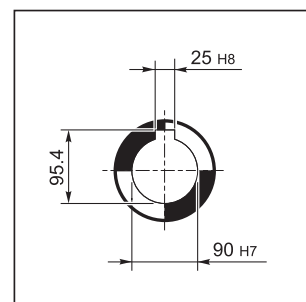

Las formas constructivas A y P llevan acoplado un ventilador de refrigeración.

		M	M1	M2	N	N1	N2	N3	N4	
VF/VF 130/210	P90 B5	24	27.3	8	200	165	130	17	11	225
VF/VF 130/210	P100 B5	28	31.3	8	250	215	180	17	13	
VF/VF 130/210	P112 B5	28	31.3	8	250	215	180	17	13	
VF/VF 130/210	P132 B5	38	40.1#	10	300	265	230	17	13	

Brida reducida

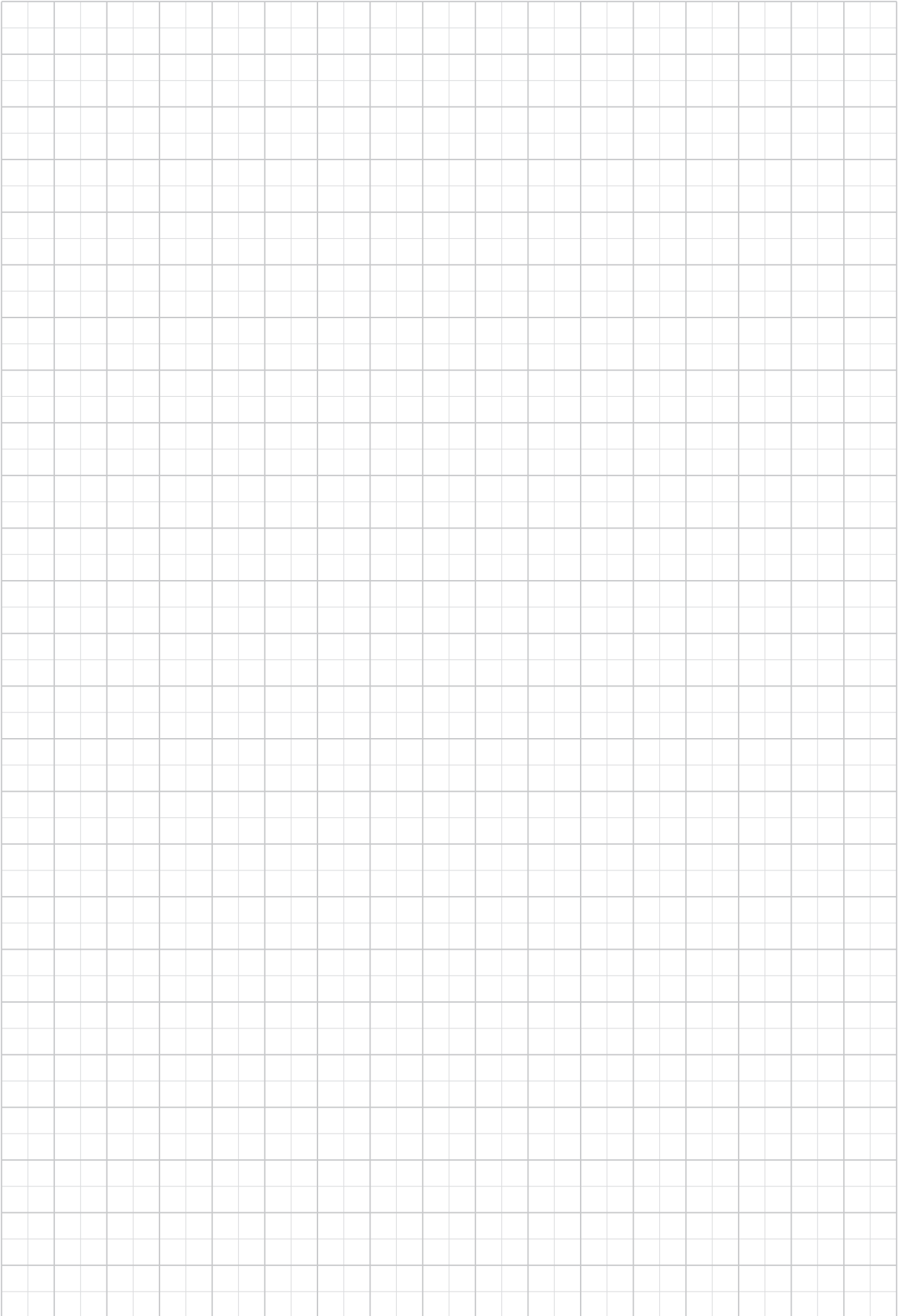
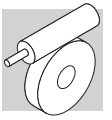



VF 250...P (IEC)

A

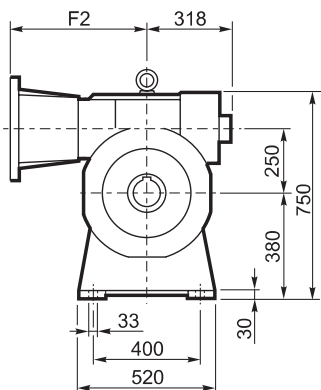
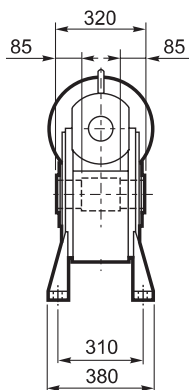

N

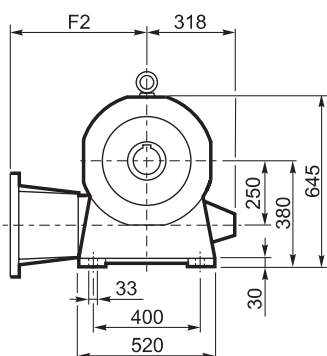
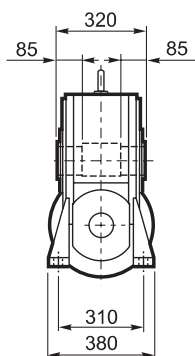

INPUT

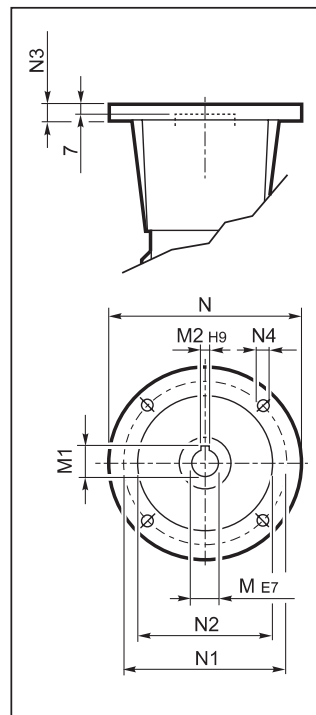

OUTPUT

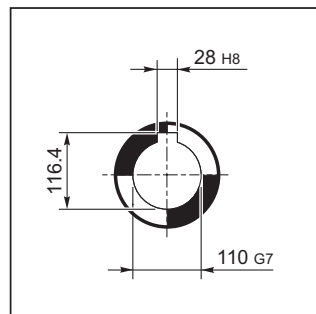

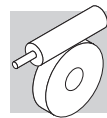

VF 250...P (IEC)

V

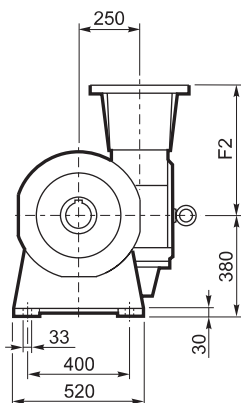
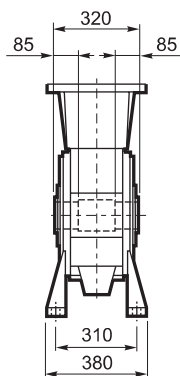

P

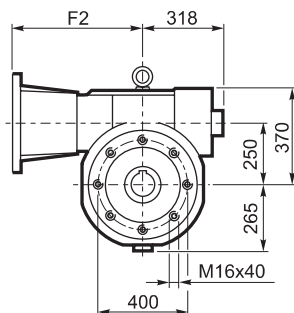
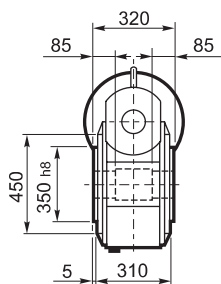

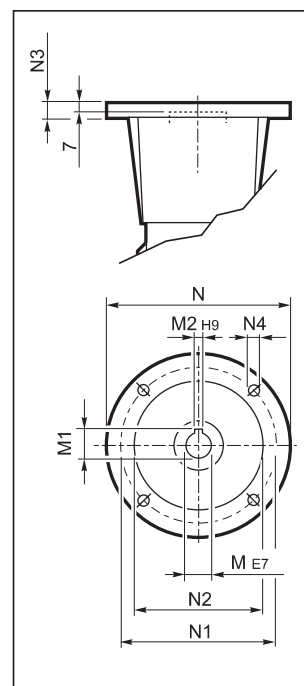

INPUT

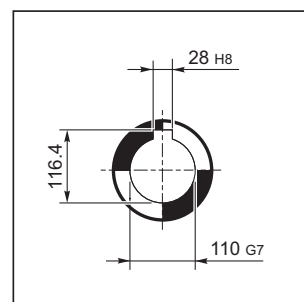

OUTPUT



Las formas constructivas A y P llevan acoplado un ventilador de refrigeración.
En la ejecución P(IEC) en el suministro, incluye de serie, el acoplamiento completo para ataque motor.

		F2	M	M1	M2	N	N1	N2	N3	N4	
VF 250	P132 B5	531	38	41.3	10	300	265	230	25	M12	310
VF 250	P160 B5	506	42	45.3	12	350	300	250	22	18	
VF 250	P180 B5	506	48	51.8	14	350	300	250	22	18	
VF 250	P200 B5	531	55	59.3	16	400	350	300	25	M16	
VF 250	P225 B5	536	60	64.4	18	450	400	350	22	18#	

N. 8 agujeros 45°



VFR 250...P (IEC)

A

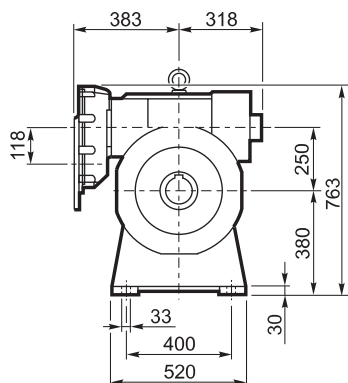
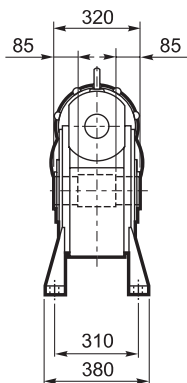

N

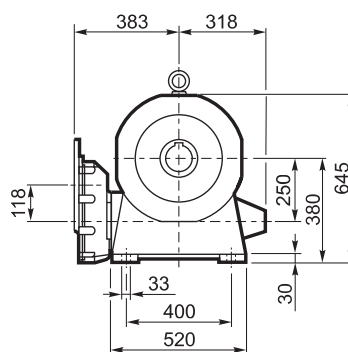
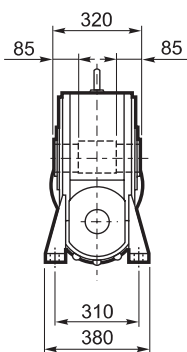

INPUT

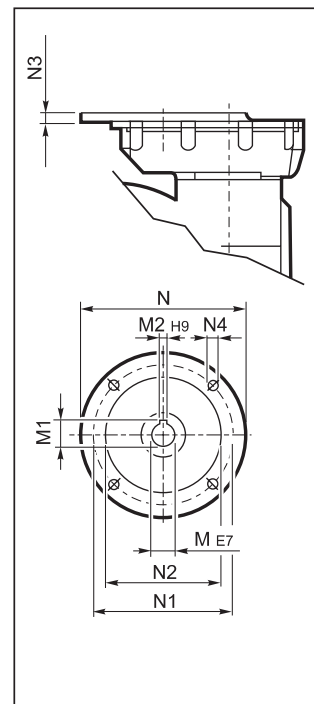

OUTPUT

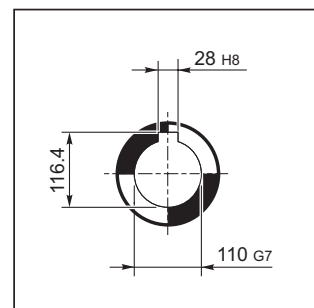



VFR 250...P (IEC)

V

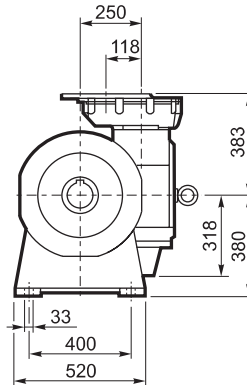
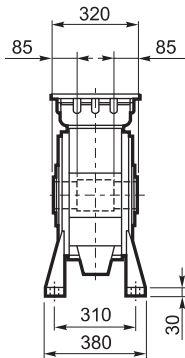

P

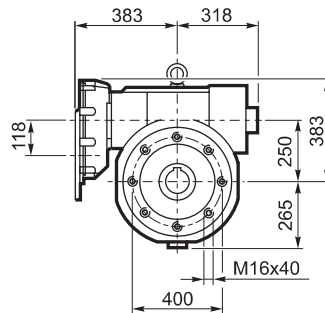
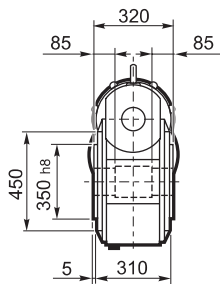

INPUT

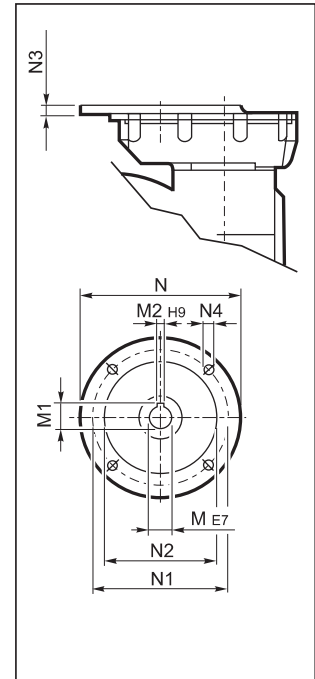

OUTPUT

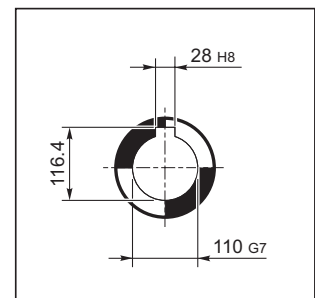

Las formas constructivas A y P llevan acoplado un ventilador de refrigeración.

		M	M1	M2	N	N1	N2	N3	N4	
VFR 250	P100 B5	28 K6	31.3	8	250	215	180	13	M12x35	295
VFR 250	P112 B5	28 K6	31.3	8	250	215	180	13	M12x35	
VFR 250	P132 B5	38 J6	41.3	10	300	265	230	13	M12x35	
VFR 250	P160 B5	42 J6	44.3#	12	350	300	250	18	M16x60	

Brida reducida



VF/VF 130/250...P (IEC)

A

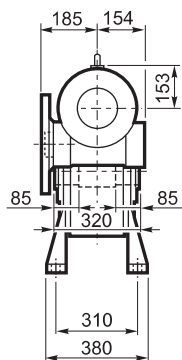
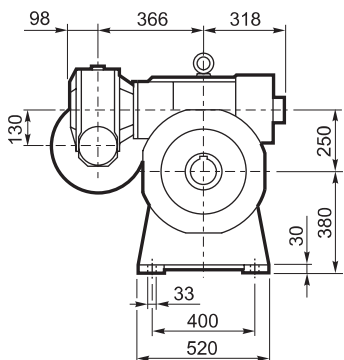

INPUT

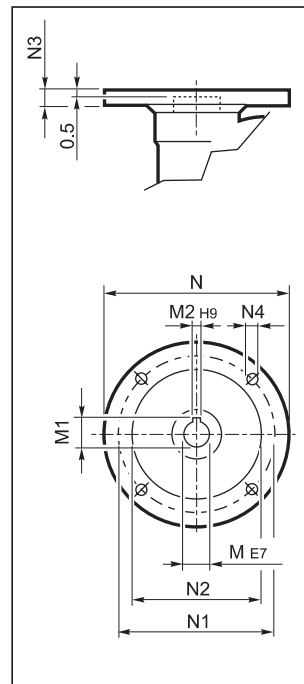

N

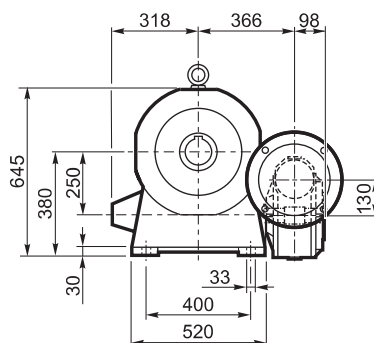
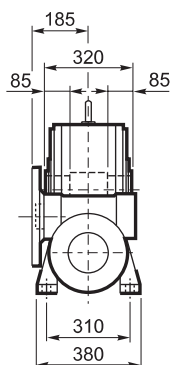

V

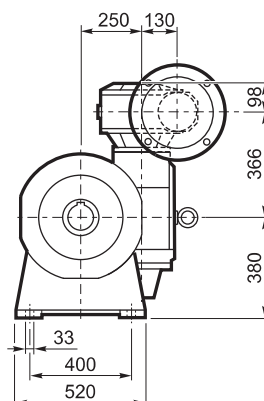
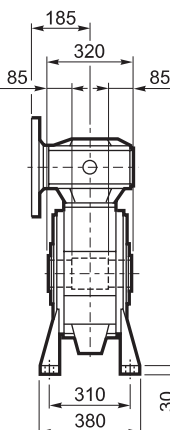

OUTPUT

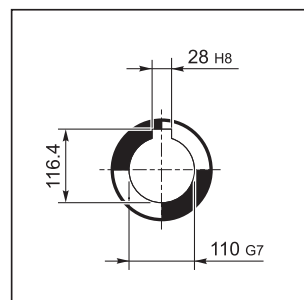

P

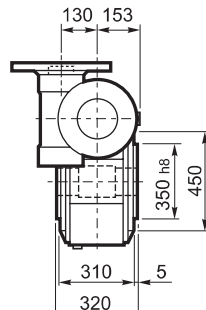
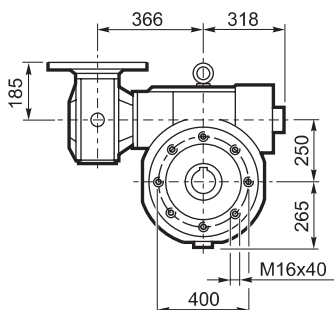

Las formas constructivas A y P llevan acoplado un ventilador de refrigeración.

		M	M1	M2	N	N1	N2	N3	N4	
VF/VF 130/250	P 90 B5	24	27.3	8	200	165	130	17	11	325
VF/VF 130/250	P100 B5	28	31.3	8	250	215	180	17	13	
VF/VF 130/250	P112 B5	28	31.3	8	250	215	180	17	13	
VF/VF 130/250	P132 B5	38	40.1#	10	300	265	230	17	13	

Brida reducida



27 DIMENSIONES REDUCTORES CON EJE DE ENTRADA HS

VF 27...HS

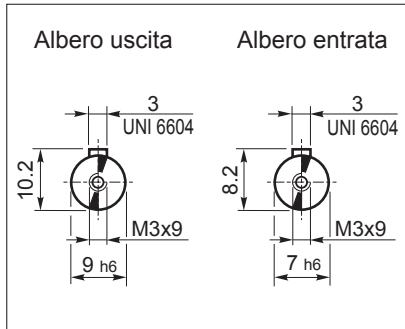

VF 27_A..HS

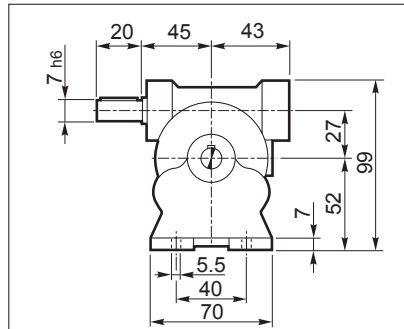

VF 27_N..HS

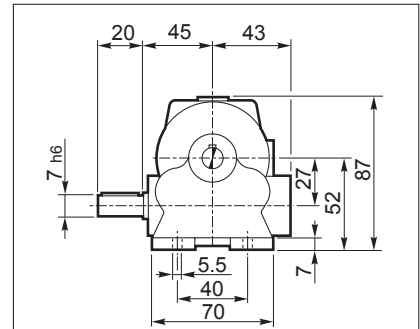

VF 27_V..HS

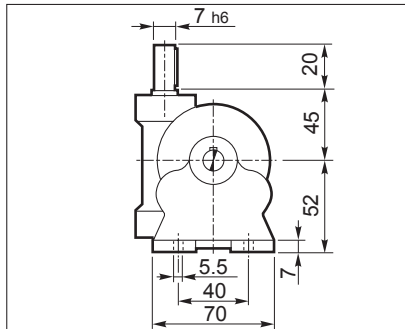

VF 27_F1..HS

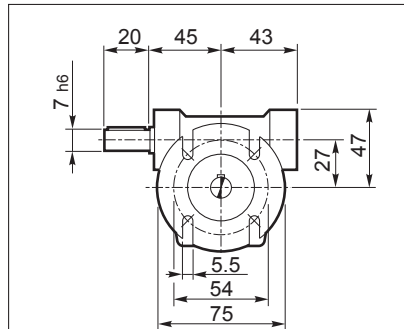

VF 27_F2..HS

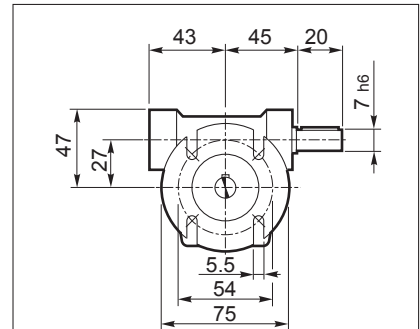

	Kg
VF 27_HS	0.73

Las dimensiones comunes con otras configuraciones están incluidas de la pág.111.



VF...HS - W...HS

VF_A..HS

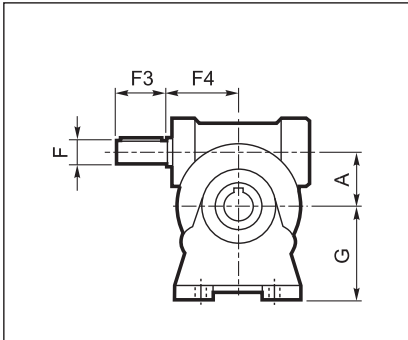

VF_V..HS

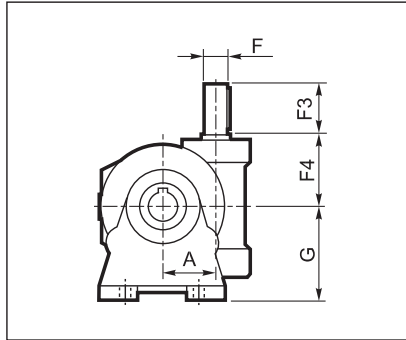

VF_N..HS

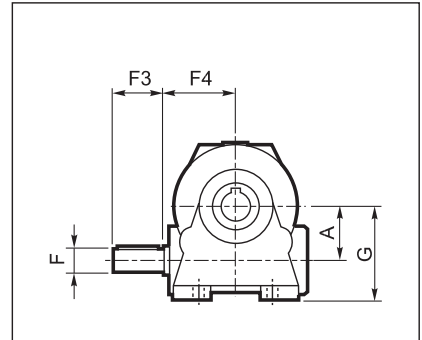

VF_P..HS

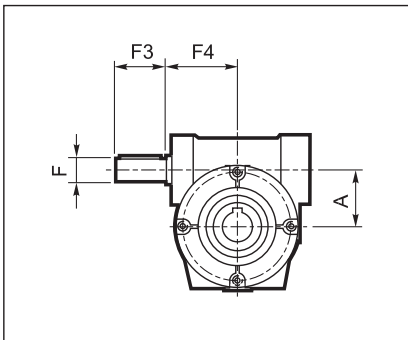

VF_FA/FC/FR/F..HS

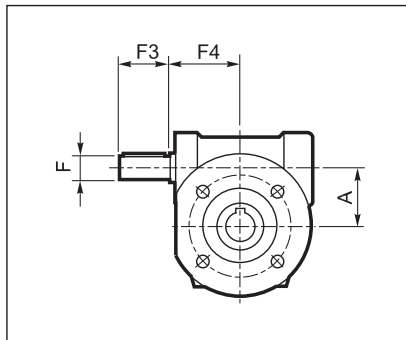

VF_U..HS

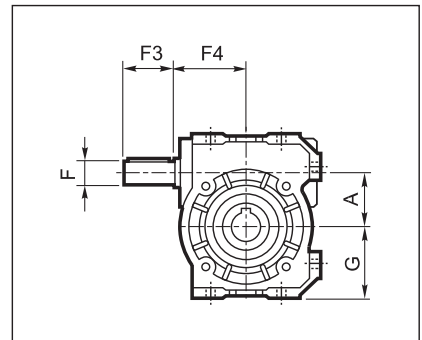

W_U..HS

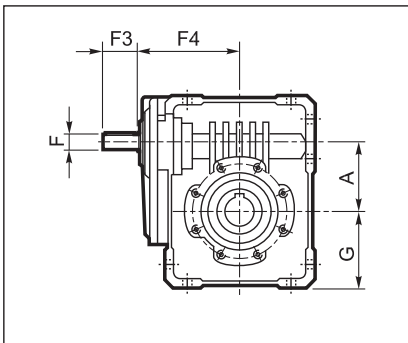

W_UF/UFC/UFCR..HS

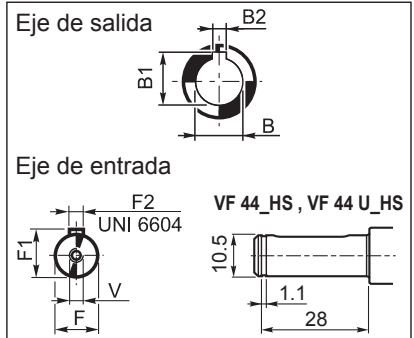
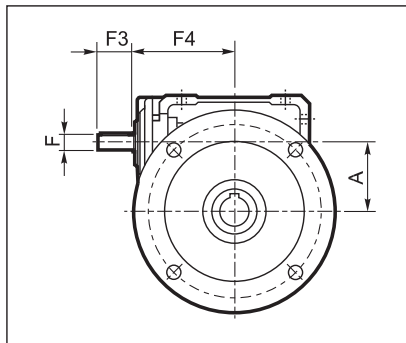

	A	B	B1	B2	F	F1	F2	F3	F4	G	V	kg
VF 30_HS	30	14 H7	16.3	5 H8	9 h6	10.2	3	20	50	55	—	1.1
VF 30_U_HS										47		
VF 44_HS	44.6	18 H7	20.8	6 H8	11 h6	12.5	4	30	54	72	—	2.0
VF 44_U_HS										55		
VF 49_HS	49.5	25 H7	28.3	8 H8	16 h6	18	5	40	65	82	M6x16	3.0
VF 49_U_HS										64.5		
W 63_HS	62.17	25 H7	28.3	8 H8	18 h6	20.5	6	40	110.5	72.5	M6x16	6.4
W 75_HS	75	30(28) H7	33.3(31.3)	8 H8	19 h6	21.5	6	40	128	87	M6x16	10.0
W 86_HS	86.9	35 H7	38.3	10 H8	25 h6	28	8	50	144	100	M8x19	14.1
W 110_HS	110.1	42 H7	45.3	12 H8	25 h6	28	8	60	168	125	M8x19	27
VF 130_HS	130	45 H7	48.8	14 H8	30 h6	33	8	60	160	195	M8x20	49
VF 150_HS	150	50 H7	53.8	14 H8	35 h6	38	10	65	185	220	M8x20	60
VF 185_HS	185.4	60 H7	64.4	18 H8	40 h6	43	12	70	214.5	254	M8x20	94
VF 210_HS	210	90 H7	95.4	25 H8	48 h6	51.5	14	110	230	335	M16x40	175
VF 250_HS	250	110 G7	116.4	28 H8	55 h6	59	16	110	275.5	380	M16x40	275

Las dimensiones comunes con otras configuraciones están incluidas de la pág.112 a pag. 173.



VFR...HS - WR...HS

VFR_A..HS

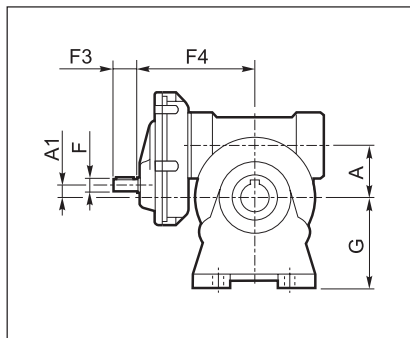

VFR_N..HS

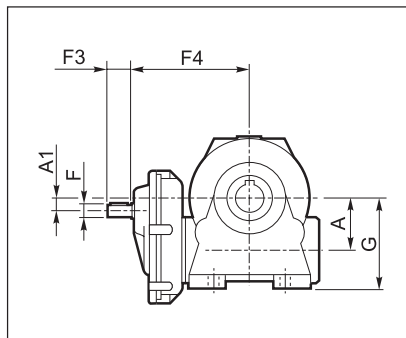

VFR_V..HS

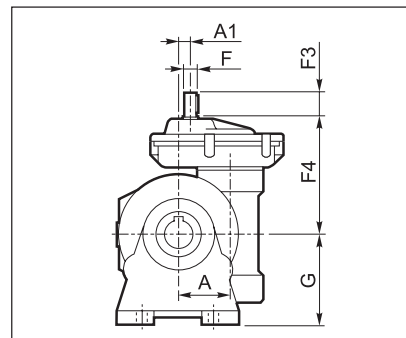

VFR_P..HS

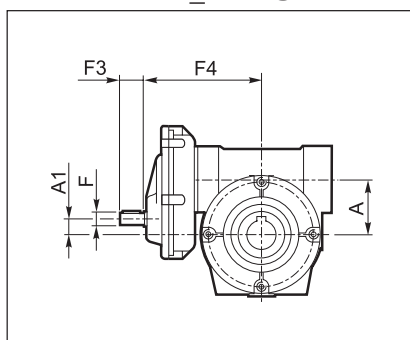

VFR_FA/FC/FR/F..HS

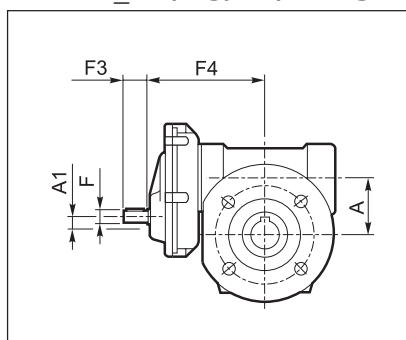

VFR_U..HS

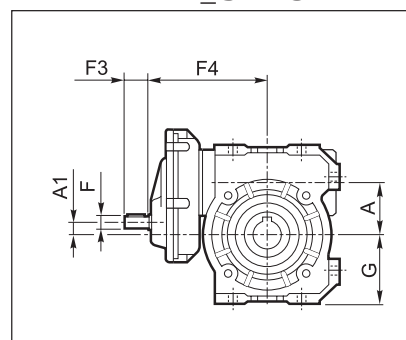

WR_U..HS

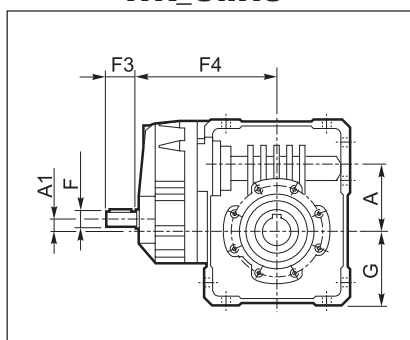

WR_UF/UFC/UFCR..HS

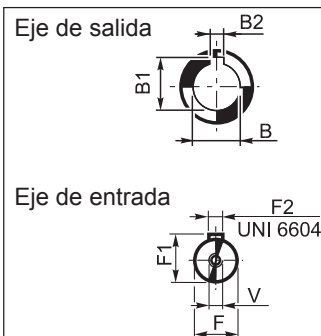
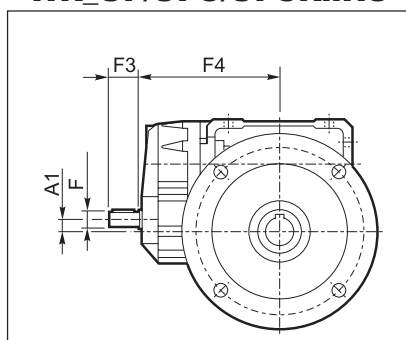

	A	A1	B	B1	B2	F	F1	F2	F3	F4	G	V	Kg
VFR 49_HS	49.5	10	25 H7	28.3	8 H8	11 h6	12.5	4	23	110	82	M4x10	5
VFR 49_U HS											64.5		
WR 63_HS	62.17	11.42	25 H7	28.3	8 H8	14 h6	16	5	30	138	72.5	M5x12.5	7.1
WR 75_HS	75	11	30(28) H7	33.3(31.3)	8 H8	19 h6	21.5	6	40	162	87	M6x16	11.1
WR 86_HS	86.9	22.9	35 H7	38.3	10 H8	19 h6	21.5	6	40	178	100	M6x16	14.7
WR 110_HS	110.1	21.1	42 H7	45.3	12 H8	24 h6	27	8	50	201	125	M8x19	34
VFR 130_HS	130	45	45 H7	48.8	14 H8	24 h6	27	8	50	228	195	M8x20	57
VFR 150_HS	150	53	50 H7	53.8	14 H8	28 h6	31	8	60	280	220	M8x20	71
VFR 185_HS	185.4	88.4	60 H7	64.4	18 H8	28 h6	31	8	60	310	254	M8x20	110
VFR 210_HS	210	92	90 H7	95.4	25 H8	38 h6	41	10	80	335	335	M10x25	185
VFR 250_HS	250	132	110 G7	116.4	28 H8	38 h6	41	10	80	383	380	M10x25	295

Las dimensiones comunes con otras configuraciones están incluidas de la pág. 122 a pag. 175.



VF/VF...HS - VF/W...HS - W/VF...HS

VF/VF_A..HS
W/VF_A..HS

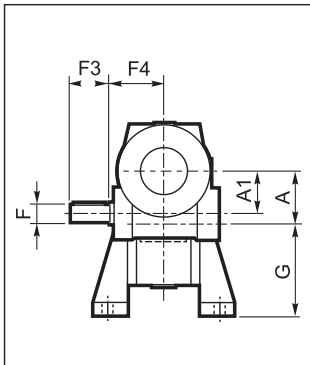

VF/VF_N..HS
W/VF_N..HS

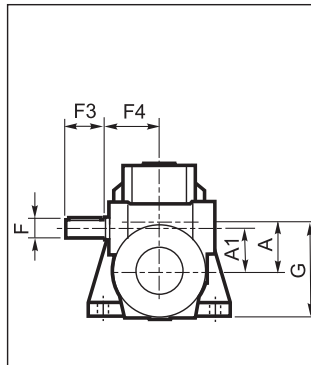

VF/VF_V..HS
W/VF_V..HS

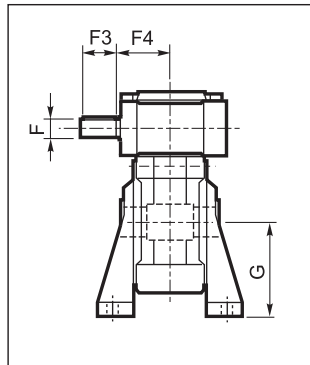

VF/VF_P..HS
W/VF_P..HS

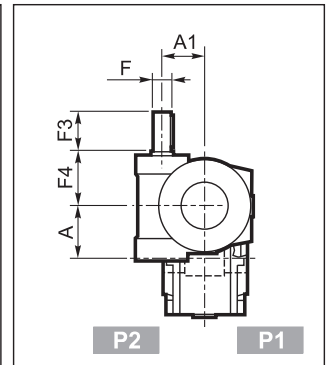

VF/W_U..HS

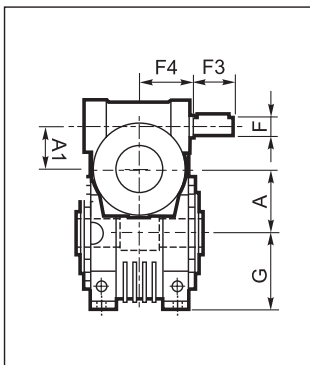

VF/VF_U..HS

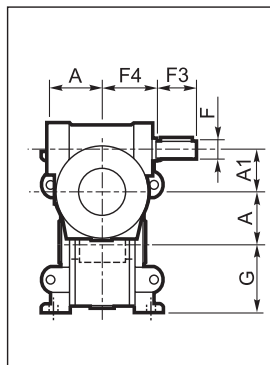

VF/VF_F/FA/FC/FR..HS
W/VF_F/FA/FC/FR..HS

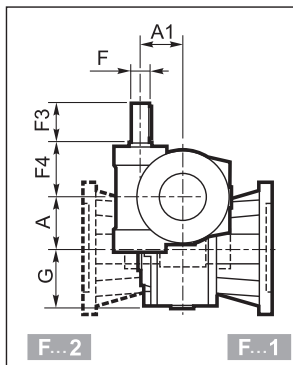

VF/W_UF/UFC/UFCR..HS

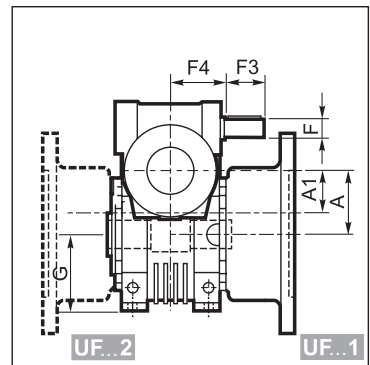

Eje de salida

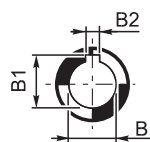

Eje de entrada

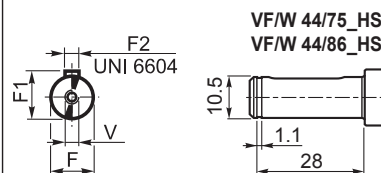

	A	A1	B	B1	B2	F	F1	F2	F3	F4	G	V	Kg
VF/VF 30/44_HS	44.6	30	18 H7	20.8	6 H8	9 h6	10.2	3	20	50	72	—	3.5
VF/VF 30/44 U HS											55		
VF/VF 30/49_HS	49.5	30	25 H7	28.3	8 H8	9 h6	10.2	3	20	50	82	—	4.5
VF/VF 30/49 U HS											64.5		
VF/W 30/63_HS	62.17	30	25 H7	28.3	8 H8	9 h6	10.2	3	20	50	100	—	7.5
VF/W 44/75_HS	75	44.6	30 (28) H7	33.3 (31.3)	8 H8	11 h6	12.5	4	30	54	115	—	16.1
VF/W 44/86_HS	86.9	44.6	35 H7	38.3	10 H8	11 h6	12.5	4	30	54	142	—	42
VF/W 49/110_HS	110.0	49.5	42 H7	45.3	12 H8	16 h6	18	5	40	65	170	M6x16	46
W/VF 63/130_HS	130	62.17	45 H7	48.8	14 H8	18 h6	20.5	6	40	110.5	72.5	M6x16	74
W/VF 86/150_HS	150	86.9	50 H7	53.8	14 H8	25 h6	28	8	50	144	100	M8x19	108
W/VF 86/185_HS	185.4	86.9	60 H7	64.4	18 H8	25 h6	28	8	50	144	100	M8x19	109
VF/VF 130/210_HS	210	130	90 H7	95.4	25 H8	30 h6	33	8	60	160	335	M8	225
VF/VF 130/250_HS	250	130	110 G7	116.4	28 H8	30 h6	33	8	60	160	380	M8	325

Las dimensiones comunes con otras configuraciones están incluidas de la pág. 118 y pag. 176.



28 DIMENSIONES PARA REDUCTORES CON BRAZO DE REACCION

VF - VFR - VF/VF - W/VF

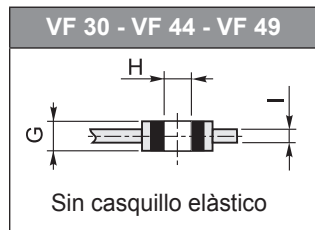
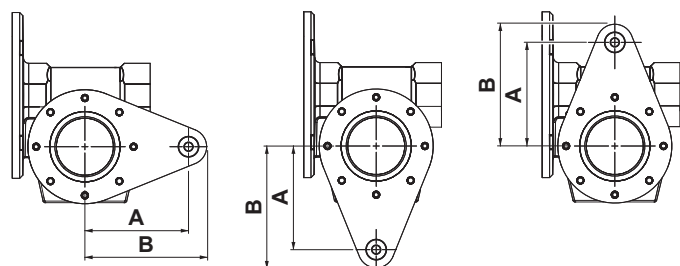

W - WR - VF/W

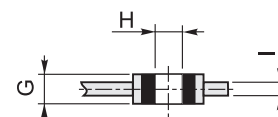
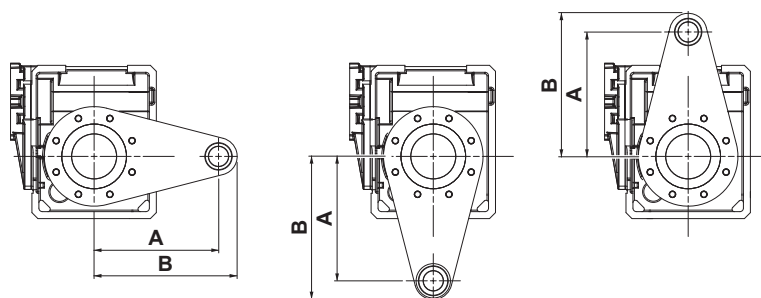

		A	B	G	H	I
VF	30	100	117.5	14	8	4
VFR	44	100	117.5	14	8	4
VF/VF	49	100	117.5	14	8	4
W	63	150	178	20	10	6
WR	75	200	237	25	20	6
VF/W	86	200	238	25	20	6
	110	250	288	25	20	6
	130	300	345	30	25	6
VF	150	300	345	30	25	6
VFR	185	350	395	30	25	6
W/VF	210	350	450	60	50	8
	250	400	500	60	50	10

Las dimensiones comunes con otras configuraciones están incluidas de la pág. 112 a pag. 176.

29 DIMENSIONES PARA REDUCTORES CON TAPÓN DE PROTECCIÓN

W - WR - VF/W

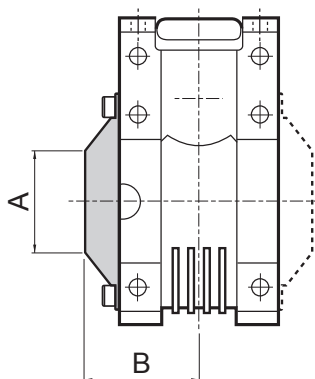

	A	B	
W	63	Ø 35	82
WR	75	Ø 54	85.5
VF/W	86	Ø 71	93.5
	110	Ø 89	103

Las dimensiones comunes con otras configuraciones están incluidas de la pág. 126 a pag. 141.



30 ACCESORIOS

30.1 Eje de salida suelto

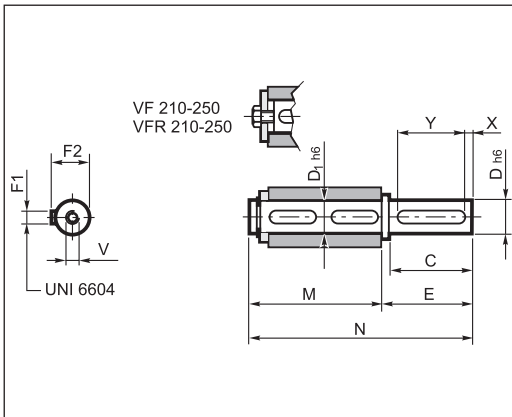

		C	D	D1	E	F1	F2	M	N	V	X	Y
VF	30	30	14	14	35	5	16	61	96	M5x13	5	20
VFR	44	40	18	18	45	6	20.5	70	115	M6x16	5	30
VF/VF	49	60	25	25	65	8	28	89	154	M8x19	5	50
	63	60	25	25	65	8	28	127	192	M8x19	5	50
W	75_D28	60	28	30	65	8	31	134	199	M8x20	5	50
WR	75_D30	60	30	30	65	8	33	134	199	M10x22	5	50
VF/W	86	60	35	35	65	10	38	149	214	M10x22	5	50
	110	75	42	42	80	12	45	164	244	M12x28	7.5	60
	130	80	45	45	85	14	48.5	176	261	M12x32	5	70
VF	150	85	50	50	93	14	53.5	185	278	M16x40	7.5	70
VFR	185	100	60	60	110	18	64	200	310	M16x40	10	80
W/VF	210	130	90	90	140	25	95	255	395	M20x50	5	120
	250	165	110	110	175	28	116	315	490	M24x64	15	140

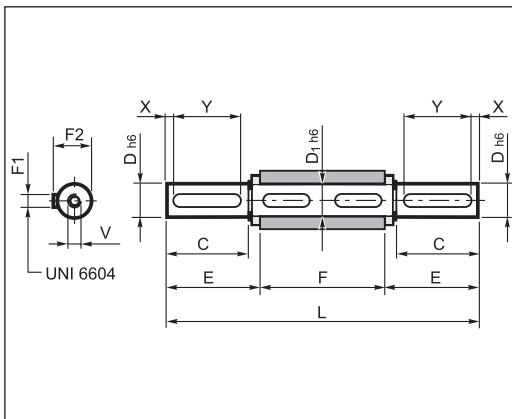

		C	D	D1	E	F	F1	F2	L	V	X	Y
VF	30	30	14	14	32.5	55	5	16	120	M5x13	5	20
VFR	44	40	18	18	42.7	64	6	20.5	149.4	M6x16	5	30
VF/VF	49	60	25	25	63.2	82	8	28	208.4	M8x19	5	50
	63	60	25	25	63.2	120	8	28	246.4	M8x19	5	50
W	75_D28	60	28	30	64	127	8	31	255	M8x20	5	50
WR	75_D30	60	30	30	64	127	8	33	255	M10x22	5	50
VF/W	86	60	35	35	64	140	10	38	268	M10x22	5	50
	110	75	42	42	79.3	155	12	45	313.5	M12x28	7.5	60
	130	80	45	45	84.7	165	14	48.5	334.5	M12x32	5	70
VF	150	85	50	50	90	175	14	53.5	355	M16x40	7.5	70
VFR	185	100	60	60	105	190	18	64	400	M16x40	10	80
W/VF	210	130	90	90	140	260	25	95	540	M20x50	5	120
	250	165	110	110	175	320	28	116	670	M24x64	15	140

30.2 Kit de patas KA, KV

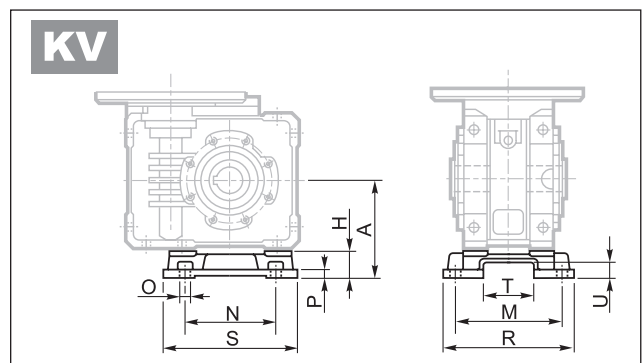
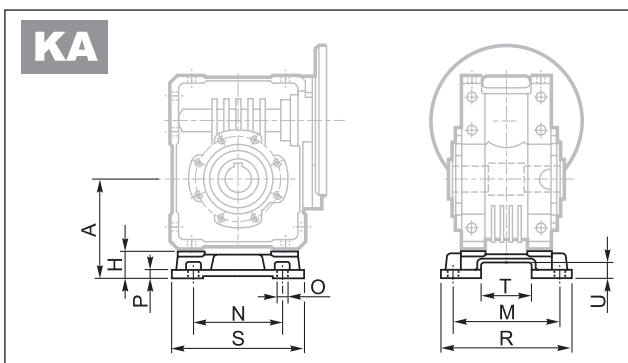

	A	H	M	N	O	P	R	S	T	U
W 63 - WR 63	100	27.5	111	95	11	8	135	145	56.5	15.5
W 75 - WR 75	115	28	115	120	11	9	139	174	56.5	15.5
W 86 - WR 86	142	42	146	140	11	11	170	200	69	20
W 110 - WR 110	170	45	181	200	13	14	210	250	69	20



31 EJE DEL CLIENTE

En la construcción del eje de la máquina que ha de acoplarse al reductor utilizar acero de buena calidad y efectuar la mecanización como se indica en el esquema siguiente.

Aconsejamos, además, completar que asegure la fijación axial del eje (no diseñado). La cantidad y dimensiones del/de lo/s taladro/s roscado/s en la extremidad del eje se determinará/ n según las diversas exigencias de la aplicación.

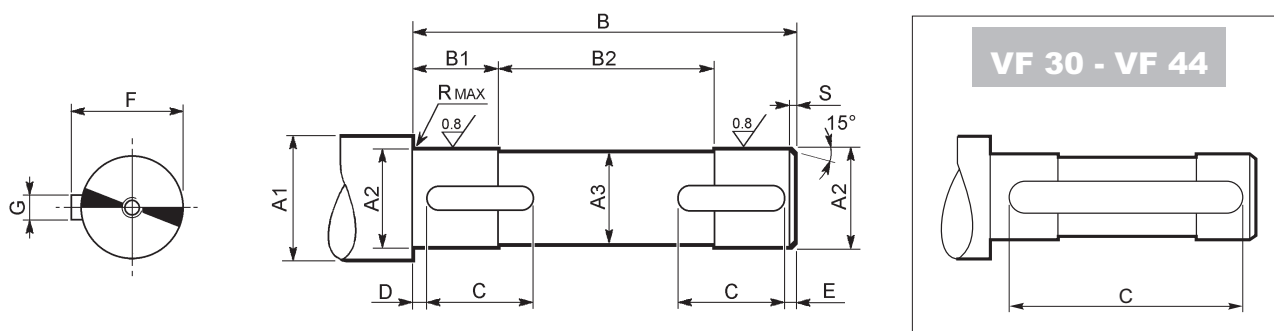

	A1	A2	A3	B	B1	B2	C	D	E	F	G	R	S	 UNI 6604
VF 30	≥ 19	14 f7	13	53	18.5	16	40	6.5	6.5	16	5 h9	0.5	1.5	5x5x40 A
VF 44	≥ 23	18 f7	17	62	22.5	17	50	6	6	20.5	6 h9	0.5	1.5	6x6x50 A
VF 49	≥ 30	25 f7	24	80	20.5	39	20	2	2	28	8 h9	1	1.5	8x7x20 A
W 63	≥ 30	25 f7	24	118	38	42	35	2	2	28	8 h9	1	1.5	8x7x35 A
W 75	≥ 35	28 f7	27	125	38	49	40	2	2	31	8 h9	1	1.5	8x7x40 A
	≥ 35	30 f7	29	125	38	49	40	2	2	33	8 h9	1	1.5	8x7x40 A
W 86	≥ 42	35 f7	34	138	43	52	40	2	2	38	10 h9	1.5	1.5	10x8x40 A
W 110	≥ 48	42 f7	41	153	43	67	50	2	2	45	12 h9	1.5	2	12x8x50 A
VF 130	≥ 52	45 f7	44	163	50.5	62	60	2.5	2.5	48.5	14 h9	2.5	2	14x9x60 A
VF 150	≥ 57	50 f7	49	173	53	67	70	2.5	2.5	53.5	14 h9	2.5	2	14x9x70 A
VF 185	≥ 68	60 f7	59	188	63	62	80	2.5	2.5	64	18 h9	2.5	2	18x11x80 A
VF 210	≥ 99	90 f7	89	258	83	92	80	3	3	95	25 h9	2.5	2.5	25x14x80 A
VF 250	≥ 121	110 h7	109	318	83	152	80	3	3	116	28 h9	2.5	2.5	28x16x80 A



32 LIMITADOR DE PAR

32.1 Descripción

El limitador de par por fricción, ha sido estudiado y fabricado para ser montados en los reductores de tornillo sinfín **VF44 - VF49** y **W 63...W 110**. Se trata de un dispositivo de protección apto para salvaguardar la transmisión de sobrecargas accidentales que pudieran dañar todos los elementos de la transmisión creando serios inconvenientes a la máquina operadora.

Con respecto a los limitadores de par tradicionales montados exteriormente al reductor, esta solución versátil presenta las siguientes ventajas:

- no varían las dimensiones externas de los reductores suministrados en versión estándar
- no precisa de ningún tipo de mantenimiento puesto que trabaja en baño de aceite
- el par de deslizamiento puede regularse fácilmente con una simple operación manual efectuada desde el exterior del reductor
- el deslizamiento, aunque sea de forma continua, no crea daños o desgastes anormales a la mecánica por cuanto las superficies de fricción están separadas continuamente por una película de aceite.



No es aconsejable su utilización en mecanismos de elevación.

32.2 Descripción del Funcionamiento

El limitador de par funciona como un embrague bicónico con las superficies de fricción mecanizadas directamente en la corona de bronce y en el cubo de fundición esferoidal GS400/12, el eje de salida es hueco y pasante, lo que permite el acoplamiento de nuestro reductor, directamente a la máquina. Las superficies cónicas están presionadas por la fuerza generada por un muelle de vaso.

La regulación del par de deslizamiento se efectúa de forma simple mediante el giro de una tuerca externa al reductor.

32.3 Protección de la instalación frente a sobrecargas

El limitador, debidamente tarado al par resistente de la máquina, protege todos los órganos mecánicos de la cadena cinemática evitando desperfectos debidos a eventuales y repetidas Sobrecargas.

32.4 Desembragado en condiciones de Irreversibilidad

En determinadas aplicaciones puede ser útil poder girar el eje de salida del reductor con la máquina parada. Esta situación no siempre es posible con los reductores de tornillo sinfín tradicionales.

Por medio de este dispositivo, podemos ejecutar fácilmente esta operación simplemente aflojando la tuerca de Regulación.



32.5 VF...L, W...L

L1								L2								
	N	A	V	U	F1 FC1 FR1 FA1	F2 FC2 FR2 FA2**	P1 P2		N	A	V	U	F1 FC1 FR1 FA1**	F2 FC2 FR2 FA2	P1 P2	
VF VF/VF*									VF VF/VF*							
	U	UF1 UFC1	UF2 UFC2	UFCR1	UFCR2				U	UF1 UFC1	UF2 UFC2	UFCR1	UFCR2			
W VF/W*									W VF/W*							

* En los reductores combinados, el limitador de par se instala sobre el 2º reductor en las ejecuciones L1 y L2, y en la ejecución LF se instala sobre el 1º reductor.

LF				
	VF/W	44/75	44/86	49/110
	W/VF	63/130	86/150	86/185

Si no ha sido previsto en la especificación, los reductores VF _ L, se suministrarán con la tuerca de regulación situada a la izquierda (L1) mirando el motor en la posición de montaje B3.

32.6 Dimensiones

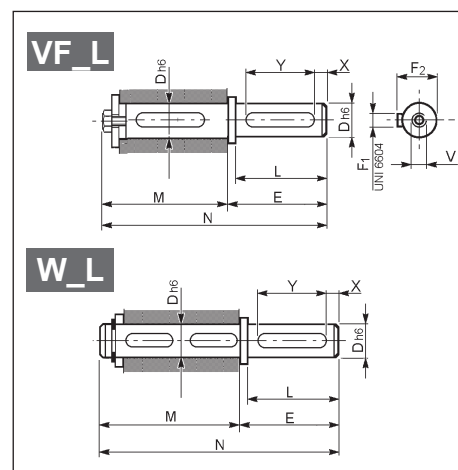
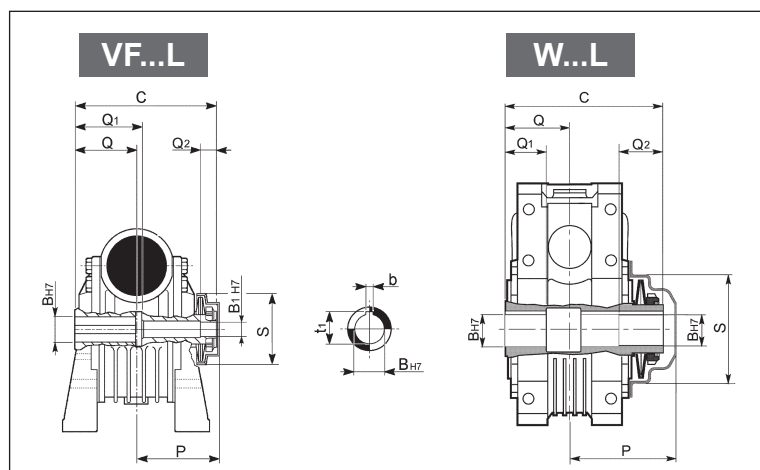

	Limitador de par										Eje de salida simple									
	C	Q	Q1	Q2	P	S	B _{H7}	B _{1H7}	t ₁	b	L	D _{h6}	E	F1	F2	M	N	V	X	Y
VF 44L	79	32	32	12	48	42.5	18	11	20.8	6	40	18	45	6	20.5	86	131	M6x16	5	30
VF 49L	105	41	51	15	63.5	66.5	25	14	28.3	8	60	25	65	8	28	114.5	179.5	M8x19	5	40
W 63L	145	60	40	40	100	77	25	-	28.3	8	60	25	65	8	28	152	217	M8x19	5	50
W 75L_D30	154.5	63.5	40	40	104	100	30	-	33.3	8	60	30	65	8	33	161.5	226.5	M10x22	5	50
W 86L	170	70	50	45	113	119	35	-	38.3	10	60	35	65	10	38	179	244	M10x22	5	50
W 110L	191	77.5	55	45	133	134	42	-	45.3	12	75	42	80	12	45	200	280	M12x28	7.5	60



32.7 Regulación del par de Deslizamiento

El pretarado del deslizamiento se realiza en fábrica sobre un momento torsor coincidente con el valor del par nominal Mn_2 [$n_1 = 1400$] del reductor tipo VF o W.

Seguidamente se describen las operaciones realizadas en fábrica para regular el tarado del par de deslizamiento. Las mismas operaciones, menos el paso (2), deberán realizarse cuando se desee un valor de par distinto del original.

1. Atornillar la tuerca de regulación hasta que la fuerza ejercida por el muelle de vaso ejerza la presión justa de forma que no permita el giro libre si se accionada manualmente.

2. Con la ayuda de un punzón y en idéntica posición angular, se realizarán dos marcas de referencia, una en la tuerca y la otra en la prolongación del eje de salida.

Esta posición de referencia constituirá el punto inicial para el contado de las vueltas de la tuerca y, consecuentemente, del tarado del par.

3. Finalmente, se girará la tuerca la fracción de vuelta correspondiente al valor del par nominal Mn_2 del reductor en cuestión. El diagrama abajo representado, y las marcas de referencia, será útil para las nuevas regulaciones que en un futuro pudieran necesitarse.

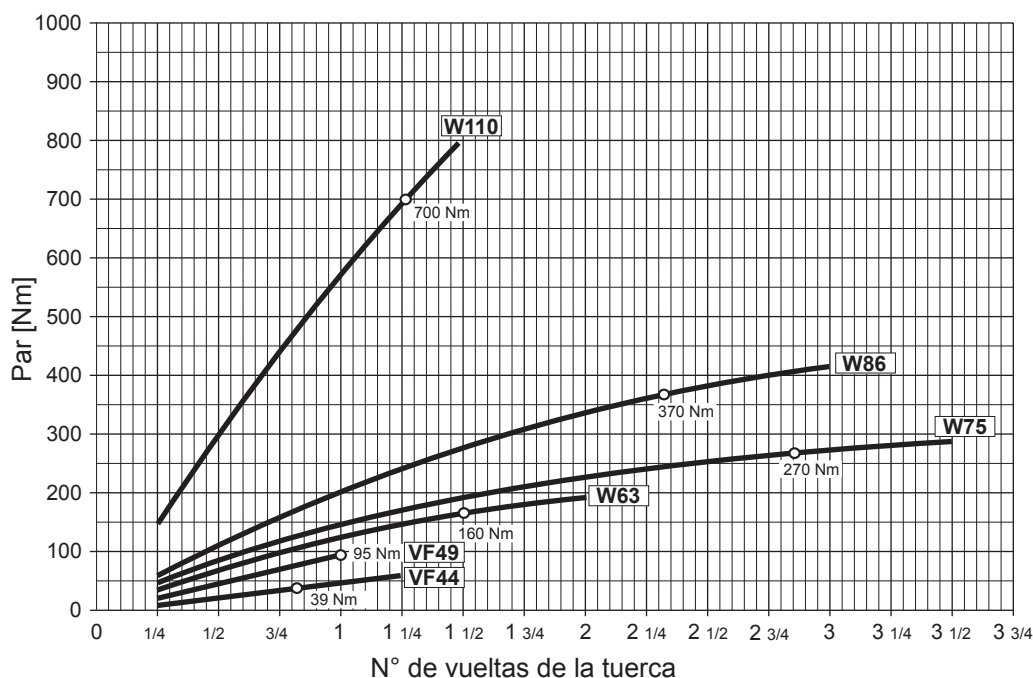

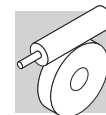

VF-EP / W-EP - REDUCTORES Y MOTORREDUCTOR PARA AMBIENTES CORROSIVOS Y ASÉPTICOS

33 PRINCIPALES BENEFICIOS DE LA SERIE EP PARA LA INDUSTRIA

Todas la empresas involucradas en las industrias químicas, farmaceuticas y de alimentos y bebidas, pueden confiar en un nuevo rango de motorreductores hechos a medida para operar efectivamente en condiciones extremadamente higiénicas y duras, entornos característicos de estos sectores.

CARACTERÍSTICAS PRINCIPALES

Ideal para la industria de la alimentación

Resistente a la corrosión

Resistente a los ambientes hostiles

Fácilmente lavable e higienizable con la mayoría de detergentes.

Estándar:

- Eje hueco de salida, tornillería y placa en acero inoxidable.
- Reductor completamente sellado (sin ventilación)
- Agujeros roscados no utilizados cerrados con tapones.
- Rejillas de ventilación específicas para el drenaje del agua.
- Protección del motor IP56
- Protección contra la corrosión C5 o Pinturas de grado alimenticio aprobadas por FDA y NSF

Opciones principales:

- Retenes adecuados para ser lavados con chorro de agua a presión.
- Lubricante compatible con los alimentos, homologado por NSF (H1) y FDA



PRINCIPALES BENEFICIOS DE LA VERSIÓN EP

Gracias a la carcasa del reductor completamente sellada, las pinturas superficiales y la protección, los motorreductores de la serie EP garantizan un funcionamiento sin riesgos en entornos hostiles e higiénicos y facilitan los procesos de desinfección del motorreductor.

Todo el motorreductor, de hecho, está protegido a través de un recubrimiento epoxi de múltiples capas de alto rendimiento con elevada resistencia a la corrosión y a la abrasión.

Se pueden seleccionar dos tipos de acabado superficial:

- La primera garantiza protección contra la corrosión C5 acorde con la ISO 9223 y está disponible como estándar en RAL9006.
- La segunda está dedicada específicamente para la industria de alimentos y bebidas y registrada por la NSF y la FDA como compatibles para el uso en áreas con posible contacto incidental con alimentos, así como para el contacto con agua potable. Además, a parte de una mejora en la resistencia a la corrosión, esta pintura es también resistente a la mayoría de detergentes usados normalmente en la industria de alimentos y bebidas.

NOTA: Este acabado es seleccionado automáticamente cuando los colores del motorreductor son Azul claro* (PLB) o Blanco* (PWH).

* Nota: No se puede especificar el color RAL ya que la pintura es de base orgánica.

Finalmente, el motorreductor EP se puede adaptar aún más a los requisitos específicos a través de varias opciones y accesorios de montaje.

Tamaños de carcasa disponibles en versión EP: 44 (excepto VFR), 49, 63, 75, 86.

Motores EP disponibles: de 0,12 a 4 kW, tanto de tipo compacto como IEC, 2, 4 y 6 polos.

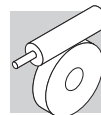

EQUIPAMIENTO DEL REDUCTOR

- ① El reductor está perfectamente sellado para prevenir la contaminación del ambiente.
- ② Eje de salida en acero inoxidable AISI 316,
- ③ Placa de reductor y tornillos en acero inoxidable.
- ④ Carcasa diseñada para el drenaje de agua para facilitar el secado después del lavado.
- ⑤ Como opción está disponible el aceite sintético clase H1 homologado por la NSF para su uso en la industria alimentaria y farmacéutica y compatibles con las normas FDA para el contacto accidental con los alimentos.

- ⑥ Disponibilidad de retenes en PTFE con alma en acero inoxidable, resistentes al lavado a presión.
- ⑦ Superficies exteriores pintadas con pinturas epoxi FDA y NSF (en función del color seleccionado) aprobadas para un contacto accidental de los alimentos.
- ⑧ Roscas no cerradas con tapones a presión.

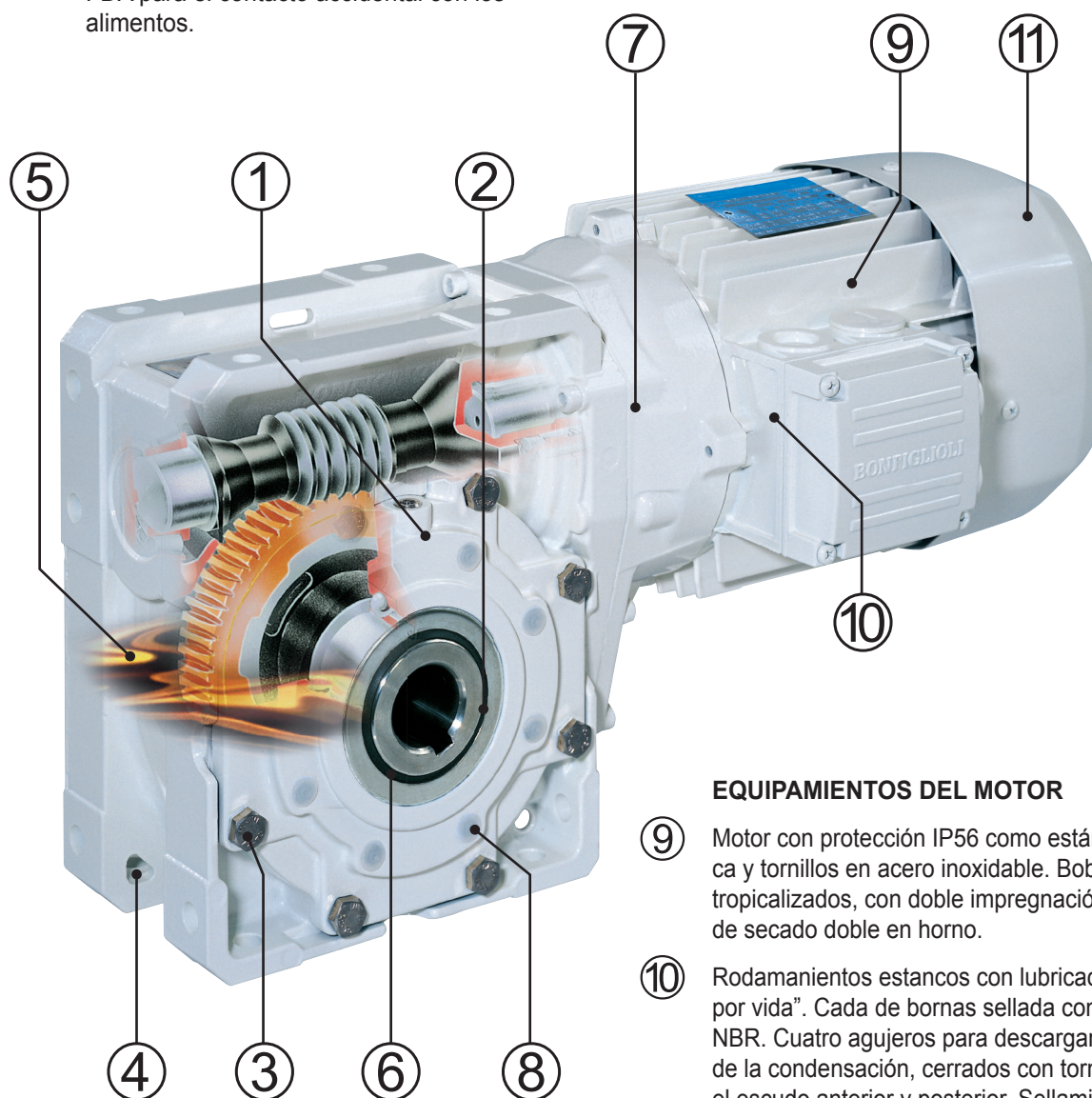

EQUIPAMIENTOS DEL MOTOR

- ⑨ Motor con protección IP56 como estándar. Placa y tornillos en acero inoxidable. Bobinados tropicalizados, con doble impregnación seguido de secado doble en horno.
- ⑩ Rodamientos estancos con lubricación "de por vida". Cada de bornas sellada con junta en NBR. Cuatro agujeros para descargar el agua de la condensación, cerrados con tornillos en el escudo anterior y posterior. Sellamiento extra en la zona de unión del motor al reductor.
- ⑪ Ventilador fabricado en polyamida, compatible con los alimentos



REDUCTOR

W-EP — 63 U 30 P90 B14 B3 PWH

OPCIONES

PINTURA

NP* sin pintura	
PWH (conforme a FDA y NSF)	
PLB (conforme a FDA y NSF)	
RAL9006 (alta resistencia a la corrosión C5)	

POSICIONES DE MONTAJE

VF-EP 44 VF-EP 49	B3
W-EP 63 W-EP 75 W-EP 86	B3 (default), B6, B7, B8, V5, V6

FORMA CONSTRUCTIVA MOTORES

B5, B14 (IEC standard)

DESIGNACION ENTRADA

	VF-EP	VF-EP R	W-EP	W-EP R
P(IEC)	 P63...P80	 P63	 P71...P112	 P63...P90
S_			 S1...S3	

RELACIÓN DE REDUCCIÓN

FORMA CONSTRUCTIVA

TAMAÑO DEL REDUCTOR

VF-EP: **44, 49**
W-EP: **63, 75, 86**

- (blank)
- R (pre-reductor helicoidal VF-EP 44)

TIPO DE REDUCTOR

VF-EP
W-EP

* Nota: Si el reductor se solicita en la versión NP (sin pintar) con brazo de reacción, este último se suministra pintado con una imprimación gris claro y que es repintable.

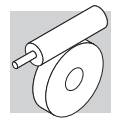



MOTOR

BN-EP 80B 4 B14 230/400-50 CLF PWH

OPCIONES

PINTURA

NP* sin pintura	
PWH (conforme a FDA y NSF)	
PLB (conforme a FDA y NSF)	
RAL9006 (alta resistencia a la corrosión C5)	

POSICIÓN CAJA DE CONEXIONES
W (default), **N, E, S**

CLASE DE AISLAMIENTO
CL F standard
CL H option

TENSIÓN-FRECUENCIA

FORMA CONSTRUCTIVA
— (motor integrado)
B5, B14 (motor IEC)

NÚMERO DE POLOS
2, 4, 6,

TAMAÑO MOTOR
1SC ... 3LC (motor integrado)
63 ... 112 (motor IEC)

TIPO MOTOR
M-EP = trifásico integrado
BN-EP = trifásico IEC



35 OPCIONES DEL REDUCTOR

PX

Opciones del retén del eje de salida. Los retenes especiales del eje de salida, extienden la aplicabilidad de los reductores a procesos en los que son frecuentes los lavados con agua a presión.

El cuerpo externos en acero INOX con doble labio añaden a la función base, una mayor resistencia a la presión externa, mientras que el material especial utilizado (PTFE), garantiza una excepcional resistencia a los elementos químicos agresivos, un bajo coeficiente de rozamientos y una vida elevada.

PV

Retenes de salida en fluoro-elastómero y mulles en acero inoxidable.

UH1

Aceite sintético compatible con los alimentos. El reductor viene de fábrica con aceite sintético "long life" certificados como H1 por la NSF para la industria farmacéutica, también cumple al norma FDA 21 CFR Sec. 178.3570.

Es un aceite sintético con base polyglicol, permite su uso en un amplio rango de temperaturas desde $-25\text{ }^{\circ}\text{C}$ a $+150\text{ }^{\circ}\text{C}$, no necesita cambios periódicos, de manera que en ausencia de contaminación, el reductor es carece prácticamente de mantenimiento.

DOCUMENTACIÓN

Certificado de conformidad (AC)

Documento en el cual se certifica la conformidad del producto con lo indicado en el pedido y su fabricación según los procedimientos estándar de producción y control que establece el sistema de calidad de Bonfiglioli Riduttori.

Certificado de prueba (CC)

La obtención de este certificado conlleva verificar la conformidad del producto con el pedido, realizar inspecciones visuales de carácter general y comprobar las dimensiones de acoplamiento. Además, exige realizar controles generales de funcionamiento en vacío y comprobar la eficacia de las juntas de retén con el sistema estático y en funcionamiento. Para llevar a cabo la prueba se utiliza una muestra estadística del lote de expedición.

36 OPCIONES DE LOS MOTORES

Las opciones disponibles para todos los motores EP son: **D3, E3, K1, H1, NH1, RC, RV, ACM, CC, CUS, S2, S3, S9.**

Para más información sobre las opciones, consultar el correspondiente capítulo en la sección de Motores Eléctricos.

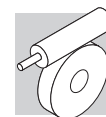

37 OTRAS INFORMACIONES SOBRE REDUCTORES Y MOTORREDUCTORES

Posiciones de montaje, datos técnicos, disponibilidad de motor, momentos de inercia y dimensiones de las series **VF-EP** y **W-EP** no cambian con respecto a sus equivalentes **VF** y **W**. De la misma manera, la información sobre todos los motores EP no cambia entre las series de motores equivalentes. Esta información se puede encontrar en los capítulos correspondientes de este catálogo.

38 ACCESORIOS PARA LA SERIE EP

En función de las necesidades aplicativas podrán necesitarse determinados accesorios como por ejemplo:

- eje de salida, ya sea simple o doble, en acero INOX tipo 316, con chaveta en el mismo material
- brazo de reacción en chapa pintado (especifique el acrónimo entre los que se muestran en la figura relacionada)
- tapa de seguridad para el eje de salida hueco en plástico (W63, W75 y W86) o de chapa metálica recubierta de goma NBR (VF 44, VF 49) con tornillería en acero INOX y grado de protección IP56.

38.1 Eje de salida suelto

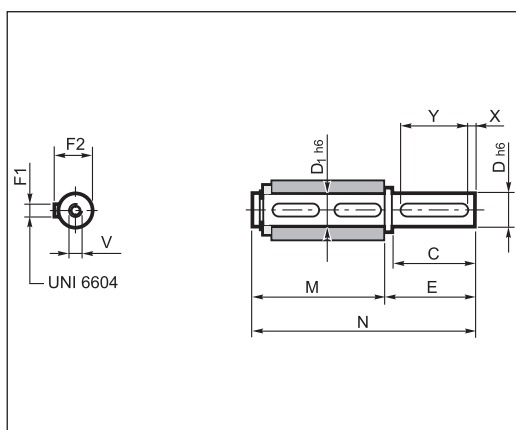

	C	D	D1	E	F1	F2	M	N	V	X	Y
VF-EP 44	40	18	18	45	6	20.5	70	115	M6x16	5	30
VF-EP 49 VF-EP R 49	60	25	25	65	8	28	89	154	M8x19	5	50
W-EP 63 W-EP R 63	60	25	25	65	8	28	127	192	M8x19	5	50
W-EP 75 W-EP R 75	60	30	30	65	8	33	134	199	M10x22	5	50
W-EP 86 W-EP R 86	60	35	35	65	10	38	149	214	M10x22	5	50

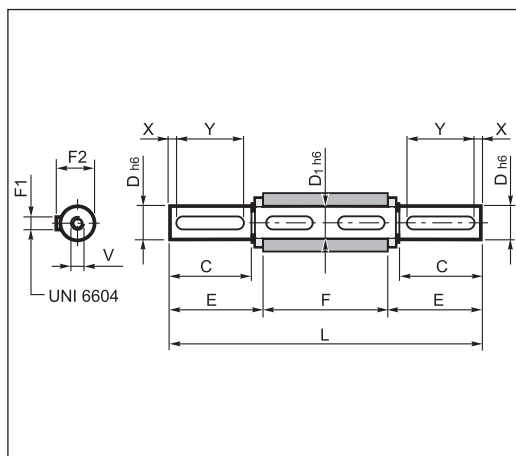

	C	D	D1	E	F	F1	F2	L	V	X	Y
VF-EP 44	40	18	18	42.7	64	6	20.5	149.4	M6x16	5	30
VF-EP 49 VF-EP R 49	60	25	25	63.2	82	8	28	208.4	M8x19	5	50
W-EP 63 W-EP R 63	60	25	25	63.2	120	8	28	246.4	M8x19	5	50
W-EP 75 W-EP R 75	60	30	30	64	127	8	33	255	M10x22	5	50
W-EP 86 W-EP R 86	60	35	35	64	140	10	38	268	M10x22	5	50



38.2 Brazo de reacción

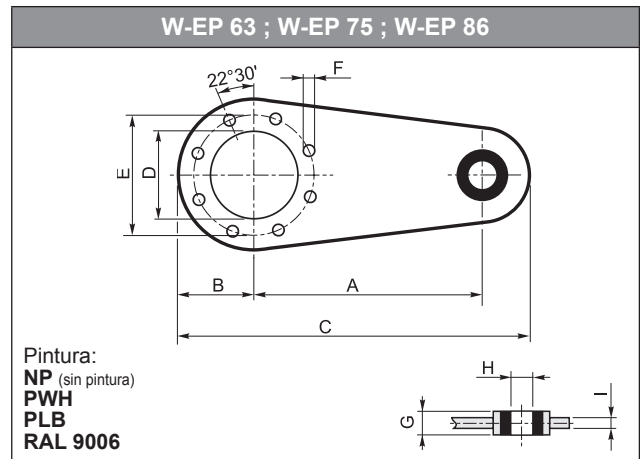
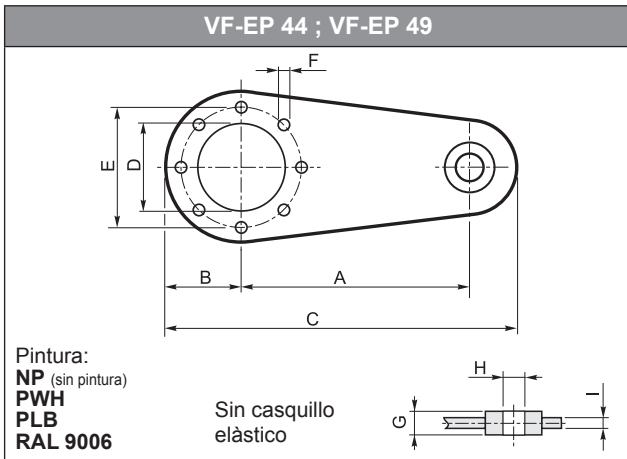

	A	B	C	D	E	F	G	H	I
VF-EP 44	100	40	157.5	50	65	7	14	8	4
VF-EP 49 VF-EP R 49	100	55	172.5	68	94	7	14	8	4
W-EP 63 W-EP R 63	150	55	233	75	90	9	20	10	6
W-EP 75 W-EP R 75	200	63	300	90	110	9	25	20	6
W-EP 86 W-EP R 86	200	80	318	110	130	11	25	20	6

38.3 Sombbrero de protección

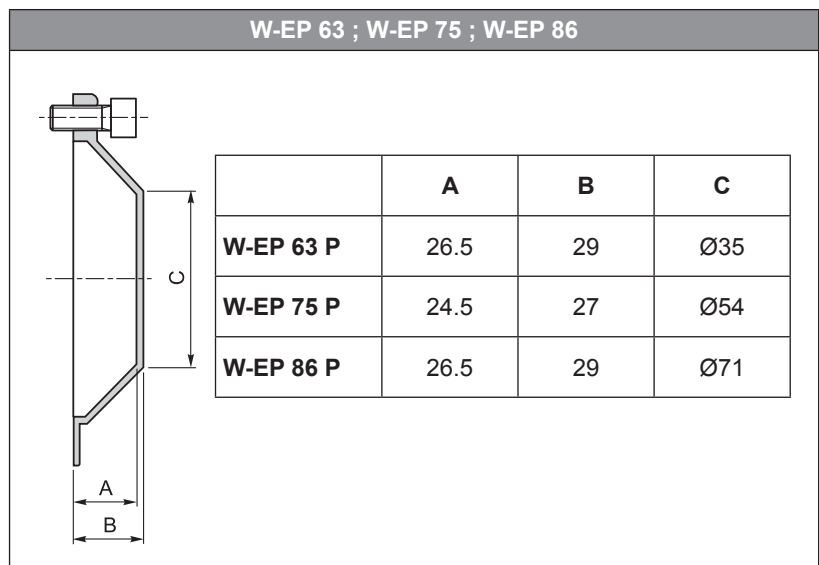
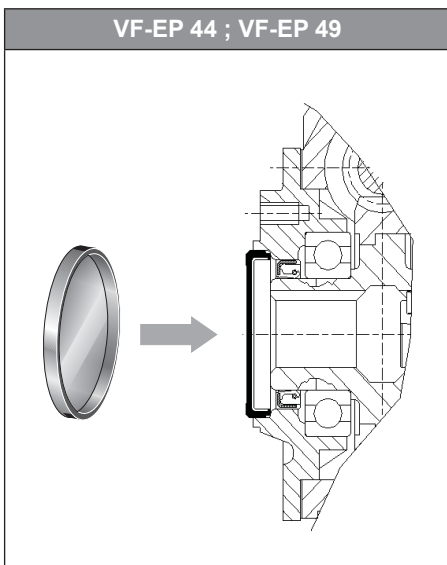

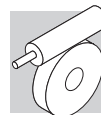

DISPOSITIVO FIN DE CARRERA RVS

39 INFORMACIONES GENERALES

El dispositivo fin de carrera, tipo RVS esta proyectado para completar y adaptar los motorreductores de vis sin-fin de Bonfiglioli en el accionamiento de:

- para cierre de ventanas e invernaderos
- cancelas automaticas
- ventanas basculantes
- dosificadores para granos en el sector zootécnico
- valvulas de mariposa

Los motorreductores con dispositivo **RVS** son idóneos para cualquier aplicación intermitente, donde se requiera un movimiento controlado y preciso.

Para las aplicaciones anteriormente descritas, caracterizadas por un tipo de servicio ligero e intermitente, se recomienda realizar la selección del grupo de transmisión, únicamente según las paginas del párrafo 40.

La selección así realizada estará de acuerdo con las particularidades del tipo de servicio y a la velocidad máxima compatible con el funcionamiento regular del dispositivo fin de carrera.

La completa configuración se obtiene ensamblando el dispositivo fin-carrera al correspondiente motorreductor, por medio del kit de montaje específico (disponible para los grupos tipo VF49, W63, W75 y W86), descritos en la paina siguiente.

Para permitir el montaje del dispositivo **RVS**, la forma constructiva de los motorreductores ha de ser embrizada.

39.1 Características técnicas

El funcionamiento del dispositivo fin de carrera se basa en el movimiento diferencial de dos pares de ruedas, dotadas de una leva excéntrica y del correspondiente accionamiento de micro-ruptores de precisión que a través de relees (a cargo del instalador) comandan el paro y la inversión del movimiento.

Las posiciones extremas del movimiento, normalmente la abertura y el cierre del marco, se sitúan fácilmente con el motorreductor ya instalado y sin necesidad de utilizar herramientas específicas, solamente se precisa una llave Allen.

Una vez alcanzada y fijada la regulación deseada, esta se mantiene constante en el tiempo, permitiendo una elevada repetividad de los accionamientos. El grupo fin de carrera **RVS** en su ejecución de base, se suministra con un par de cables conectados internamente, de aprox. de un metro longitud. El grupo además esta disponible en las siguientes variantes:

RVS ME: dotado con caja de conexiones externa con seis terminales para conectar los cables de conexión con los relees.

RVS DM: equipado de serie con el doble de micro-ruptores en serie, lo cual proporciona una absoluta seguridad de intervención, conforme a la Norma que previene el fallo de este dispositivo.

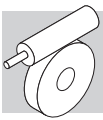



RVS ME DM: dispositivo dotado con caja de conexiones externa y doble serie de micro-ruptores, como se ha indicado anteriormente.

En todas sus variantes el dispositivo fin de carrera se caracteriza por:

- extremadamente silencioso
- dimensiones limitadas
- de fácil instalación y regulación
- con protección general IP55
- regulable dentro de un campo de regulación máximo de 43 vueltas del eje de salida

40 CODIGOS PARA PEDIDOS

Para la aplicación concreta, es necesario personalizar el dispositivo o su variante, refiriéndose a la tabla de abajo para determinar el código del pedido:

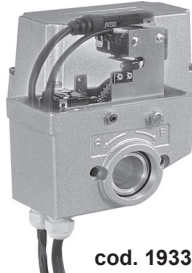
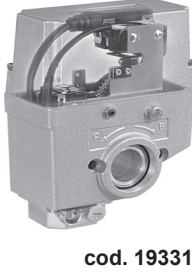
RVS	RVS ME	RVS DM	RVS ME DM
			
cod. 193312025	cod. 193312026	cod. 193312027	cod. 193312028

Seleccionar además el código relativo al kit de configuración para el reductor en el que se quiere instalar el dispositivo fin de carrera:

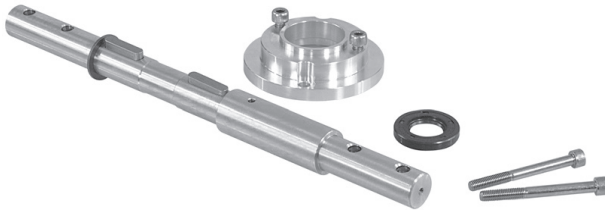
			
cod. 192860001	cod. 192860002	cod. 192860003	cod. 192860004

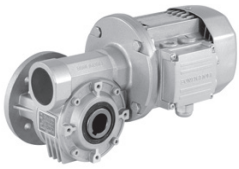
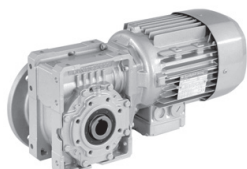
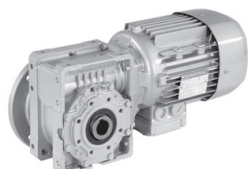
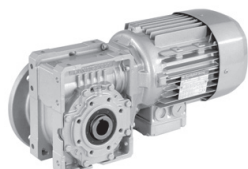
			
VF 49 F - VFR 49 F	W 63 UFC - WR 63 UFC	W 75 UFC - WR 75 UFC	W 86 UFC - WR 86 UFC



41 DESIGNACIÓN

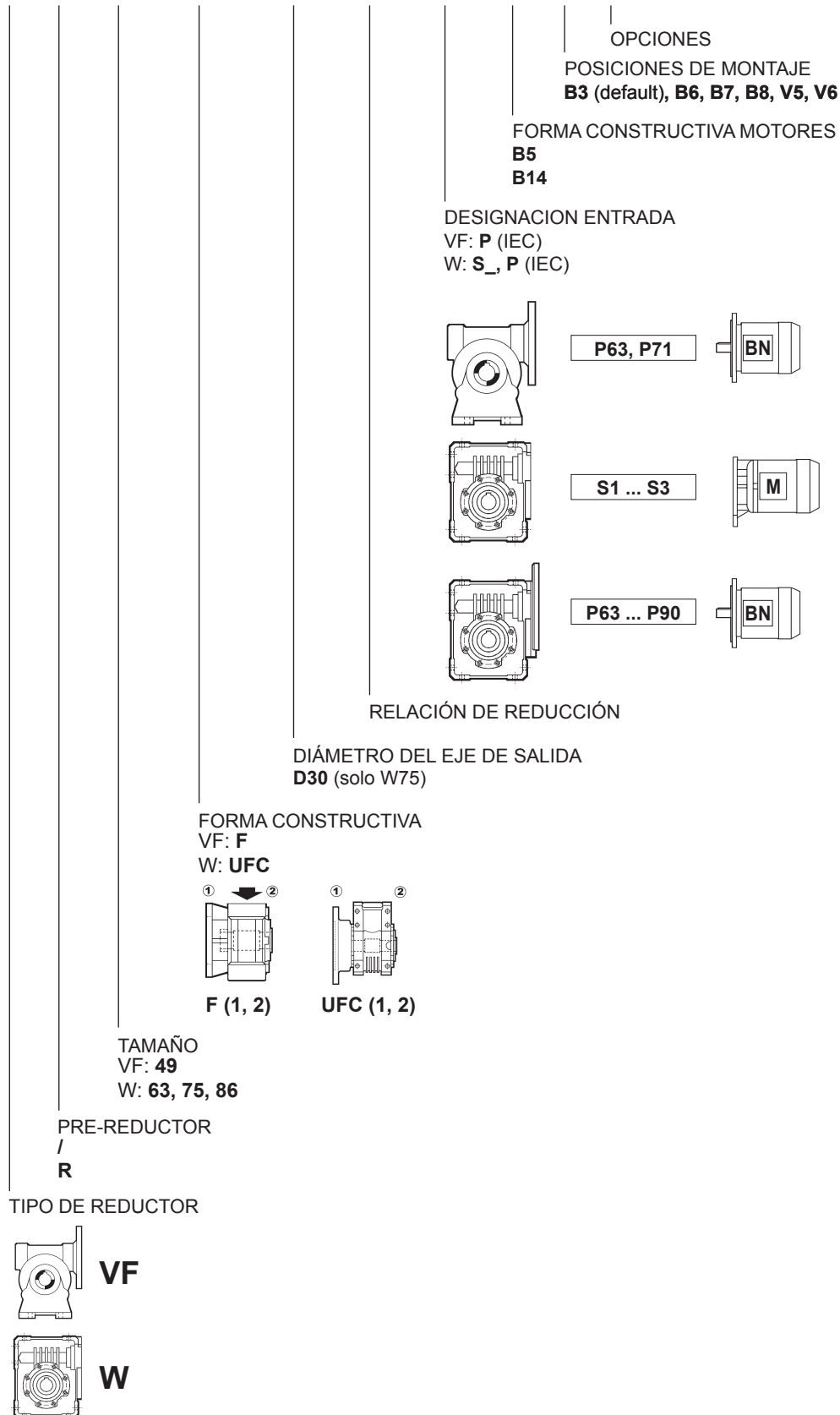

Designación **VF** y **W** para acoplamiento al dispositivo fin de carrera.

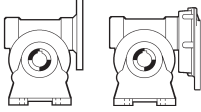

W R 75 UFC1 D30 240 P71 B5 B3

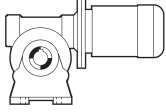

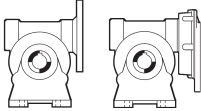
**42 TABLA DE SELECCIÓN MOTORREDUTOR**

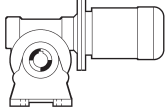
0.12 kW					
n_2 min ⁻¹	M_2 Nm	i		IEC 	
4.7	98	300	VFR 49_300	P63 BN63A4	
5.8	89	240	VFR 49_240	P63 BN63A4	
6.7	83	210	VFR 49_210	P63 BN63A4	
7.8	76	180	VFR 49_180	P63 BN63A4	
10.4	64	135	VFR 49_135	P63 BN63A4	
14.0	41	100	VF 49_100	P63 BN63A4	
17.5	37	80	VF 49_80	P63 BN63A4	
20.0	34	70	VF 49_70	P63 BN63A4	
23.3	31	60	VF 49_60	P63 BN63A4	

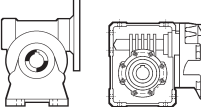
0.18 kW					
n_2 min ⁻¹	M_2 Nm	i		IEC 	
7.8	112	180	VFR 49_180	P63 BN63B4	
10.4	95	135	VFR 49_135	P63 BN63B4	
14.0	61	100	VF 49_100	P63 BN63B4	
17.5	54	80	VF 49_80	P63 BN63B4	
20.0	49	70	VF 49_70	P63 BN63B4	
23.3	45	60	VF 49_60	P63 BN63B4	

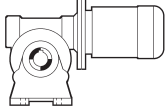
0.25 kW					
n_2 min ⁻¹	M_2 Nm	i		IEC 	
4.7	214	300	WR 63_300	P71 BN71A4	
5.8	192	240	WR 63_240	P71 BN71A4	
7.3	170	192	WR 63_192	P71 BN71A4	
10.4	136	135	WR 63_135	P71 BN71A4	
12.3	121	114	WR 63_114	P71 BN71A4	
14.0	82	100	VF 49_100	P71 BN71A4	
17.5	72	80	VF 49_80	P71 BN71A4	
20.0	66	70	VF 49_70	P71 BN71A4	
23.3	61	60	VF 49_60	P71 BN71A4	

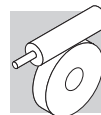

0.37 kW

n_2 min ⁻¹	M_2 Nm	i		IEC				
4.7	382	300	WR 86_300	P71	BN71B4			
5.8	306	240	WR 75_240	P71	BN71B4			
7.3	290	192	WR 86_192	P71	BN71B4			
7.8	257	180	WR 75_180	P71	BN71B4			
9.3	226	150	WR 75_150	P71	BN71B4			
10.4	204	135	WR 63_135	P71	BN71B4			
12.3	181	114	WR 63_114	P71	BN71B4			
14.0	133	100	W 63_100	P71	BN71B4	W 63_100	S1	M1SD4
17.5	108	80	VF 49_80	P71	BN71B4			
20.0	98.3	70	VF 49_70	P71	BN71B4			
23.3	90.5	60	VF 49_60	P71	BN71B4			



0.55 kW

n_2 min ⁻¹	M_2 Nm	i		IEC				
4.7	559	300	WR 86_300	P80	BN80A4			
5.8	483	240	WR 86_240	P80	BN80A4			
7.3	423	192	WR 86_192	P80	BN80A4			
7.8	376	180	WR 75_180	P80	BN80A4			
8.3	383	168	WR 86_168	P80	BN80A4			
9.3	331	150	WR 75_150	P80	BN80A4			
10.1	330	138	WR 86_138	P80	BN80A4			
11.7	287	120	WR 75_120	P80	BN80A4			
14.0	194	100	W 63_100	P80	BN80A4	W 63_100	S1	M1LA4
17.5	170	80	W 63_80	P80	BN80A4	W 63_80	S1	M1LA4
21.9	148	64	W 63_64	P80	BN80A4	W 63_64	S1	M1LA4
23.3	148	60	W 75_60	P80	BN80A4	W 75_60	S1	M1LA4

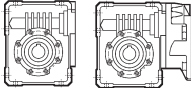

0.75 kW

n_2 min ⁻¹	M_2 Nm	i		IEC				
7.3	568	192	WR 86_192	P80	BN80B4			
8.3	514	168	WR 86_168	P80	BN80B4			
9.3	444	150	WR 75_150	P80	BN80B4			
10.1	443	138	WR 86_138	P80	BN80B4			
11.7	386	120	WR 75_120	P80	BN80B4			
14.0	281	100	W 75_100	P80	BN80B4	W 75_100	S2	M2SA4
17.5	241	80	W 75_80	P80	BN80B4	W 75_80	S2	M2SA4
21.9	199	64	W 63_64	P80	BN80B4	W 63_64	S2	M2SA4
23.3	199	60	W 75_60	P80	BN80B4	W 75_60	S2	M2SA4

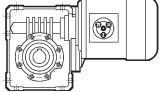
**1.1 kW**

n_2 min ⁻¹	M_2 Nm	i				
10.1	652	138	WR 86_138	P90	BN90S4	
11.7	594	120	WR 86_120	P90	BN90S4	
14.0	443	100	W 86_100	P90	BN90S4	W 86_100 S2 M2SB4
17.5	384	80	W 86_80	P90	BN90S4	W 86_80 S2 M2SB4
21.9	326	64	W 86_64	P90	BN90S4	W 86_60 S2 M2SB4

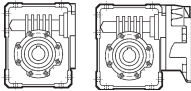
1.5 kW

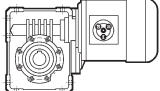
n_2 min ⁻¹	M_2 Nm	i				
11.7	816	120	WR 86_120	P90	BN90LA4	
17.5	527	80	W 86_80	P90	BN90LA4	W 86_80 S3 M3SA4
21.9	448	64	W 86_64	P90	BN90LA4	W 86_60 S3 M3SA4

43 DIMENSIONES

VF 49_F - VFR 49_F

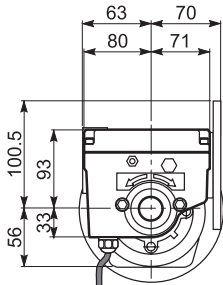

VF 49_F

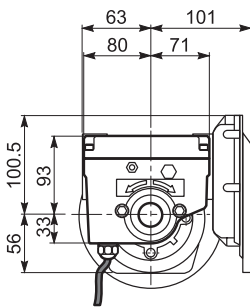
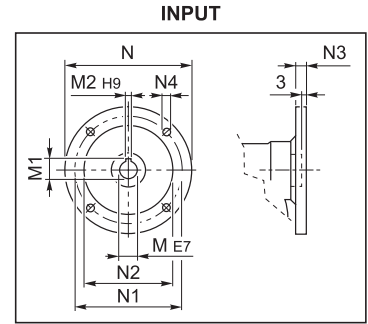
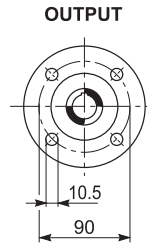
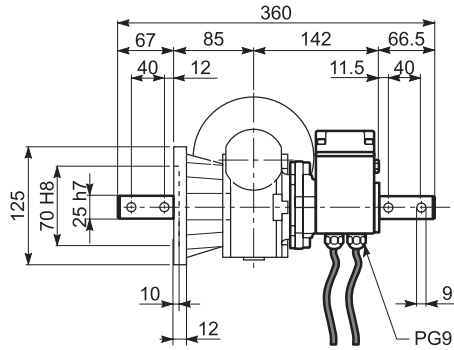

VFR 49_F

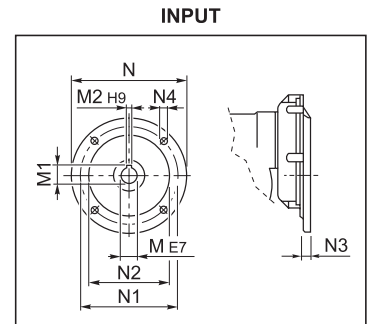
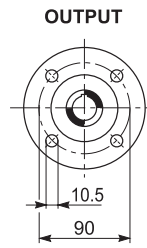
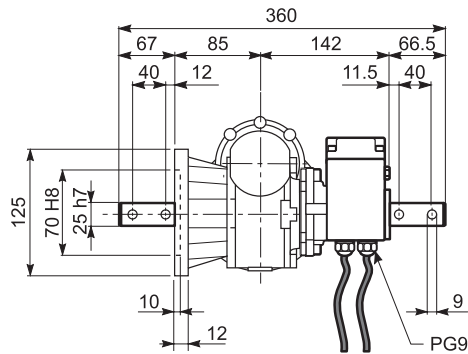

	M	M1	M2	N	N1	N2	N3	N4
VF 49_P 63	11	12.8	4	140	115	95	10.5	9.5
VF 49_P 71	14	16.3	5	160	130	110	10.5	9.5
VFR 49_P 63	11	12.8	4	140	115	95	11	M8x19



W 63 UFC_M - W 63 UFC - WR 63 UFC

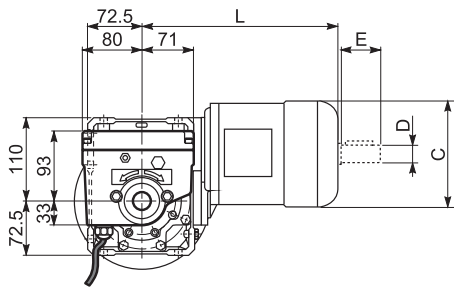

W 63 UFC_M

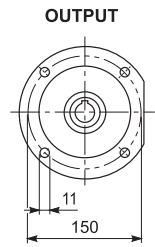
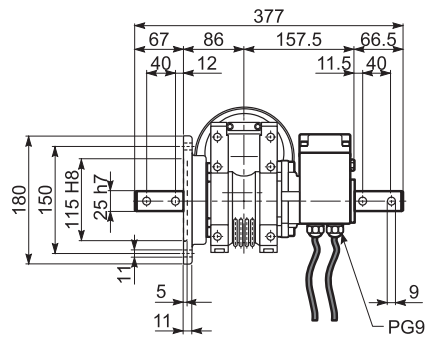
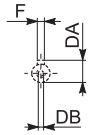

	C	D	DA	DB	E	F	L
W 63_S1 M1L	138	14	16	M5	30	5	289
W 63_S2 M2S	156	19	21.5	M6	40	6	317

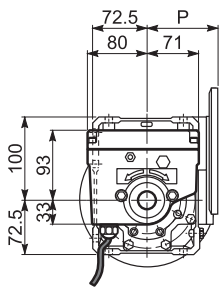

W 63 UFC

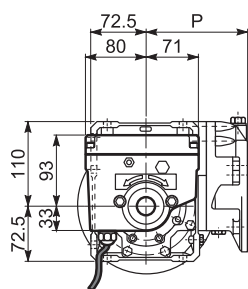
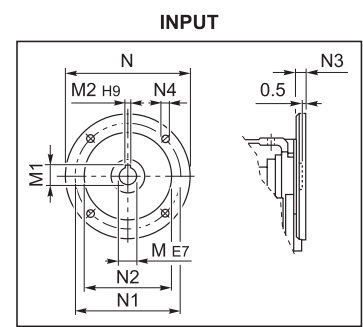
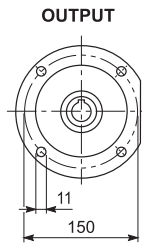
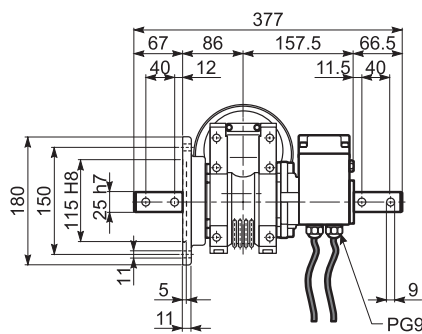

WR 63 UFC

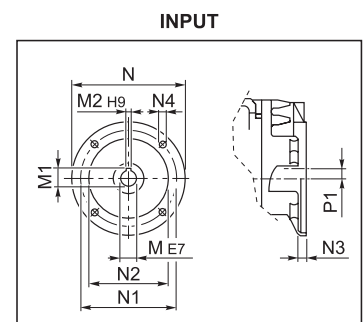
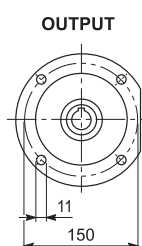
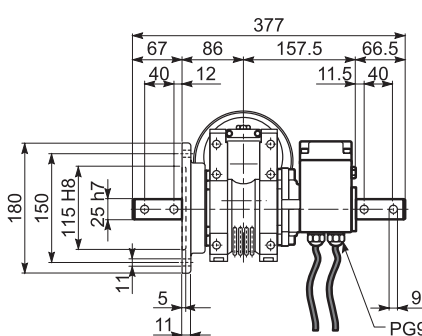

	M	M1	M2	N	N1	N2	N3	N4	P	P1
W 63_P 71	14	16.3	5	160	130	110	11	9	95	-
W 63_P 80	19	21.8	6	200	165	130	12	11.5	102	-
W 63_P 90	24	27.3	8	200	165	130	12	11.5	102	-
WR 63_P 63	11	12.8	4	140	115	95	10	M8x10	133.5	11.42
WR 63_P 71	14	16.3	5	160	130	110	10	M8x10	133.5	11.42

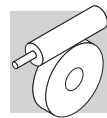

W 75 UFC_M - W 75 UFC - WR 75 UFC

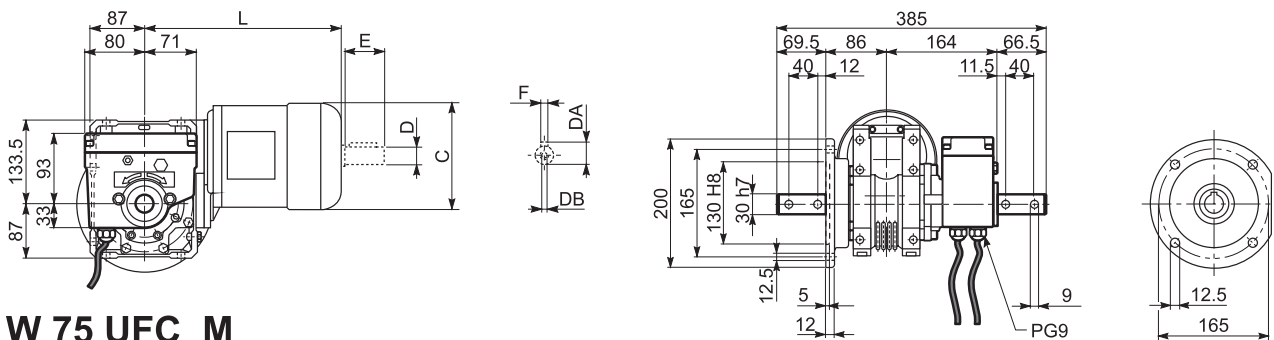

W 75 UFC_M

	C	D	DA	DB	E	F	L
W 75_S1 M1L	138	14	16	M5	30	5	308
W 75_S2 M2S	156	19	21.5	M6	40	6	333
W 75_S3 M3S	193	28	31	M10	60	8	376
W 75_S3 M3L	193	28	31	M10	60	8	408

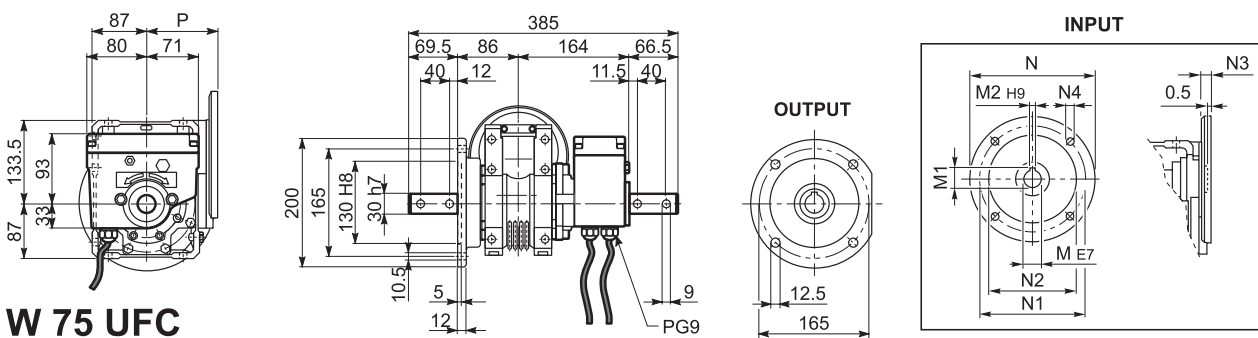

W 75 UFC

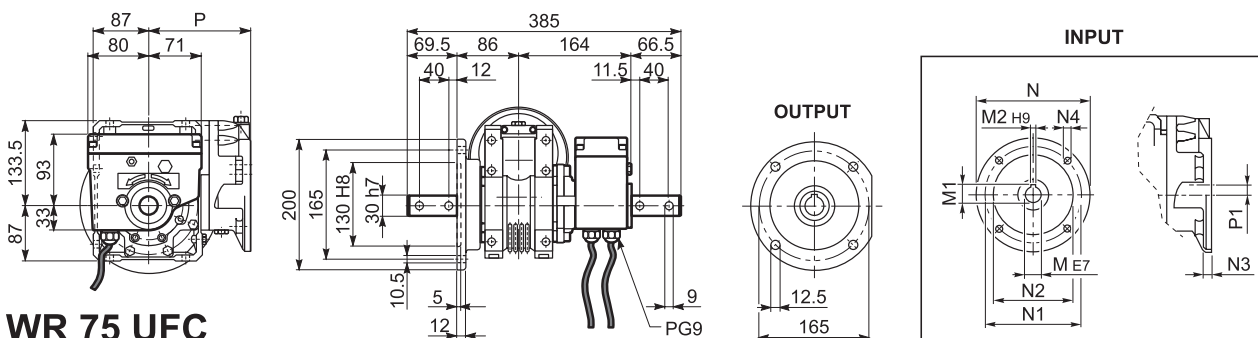

WR 75 UFC

	M	M1	M2	N	N1	N2	N3	N4	P	P1
W 75_P 71	14	16.3	5	160	130	110	11	9	112	-
W 75_P 80	19	21.8	6	200	165	130	12	11.5	112	-
W 75_P 90	24	27.3	8	200	165	130	12	11.5	112	-
WR 75_P 63	11	12.8	4	140	115	95	10	M8x10	152	23.53
WR 75_P 71	14	16.3	5	160	130	110	10	M8x10	152	23.53
WR 75_P 80	19	21.8	6	200	165	130	12	M10x13	163.5	11
WR 75_P 90	24	27.3	8	200	165	130	12	M10x13	163.5	11



W 86 UFC_M - W 86 UFC - WR 86 UFC

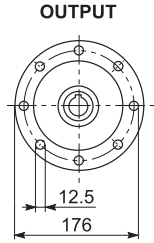
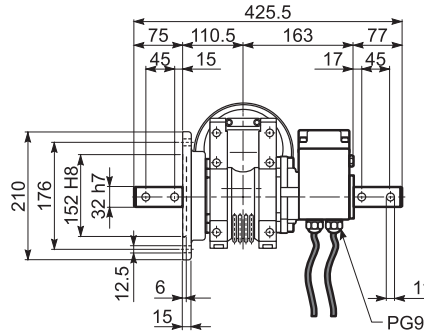
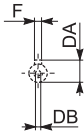
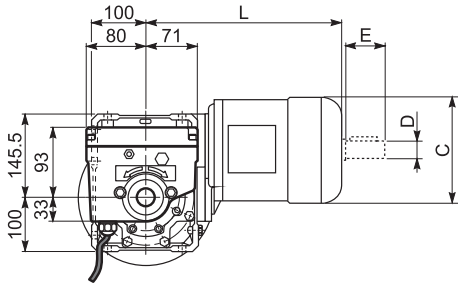

W 86 UFC_M

	C	D	DA	DB	E	F	L
W 86_S1 M1L	138	14	16	M5	30	5	324
W 86_S2 M2S	156	19	21.5	M6	40	6	349
W 86_S3 M3S	193	28	31	M10	60	8	392
W 86_S3 M3L	193	28	31	M10	60	8	424

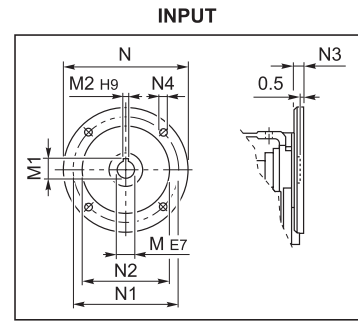
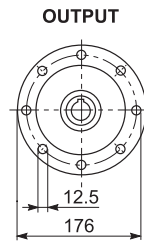
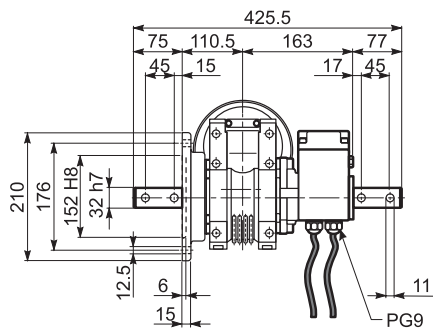
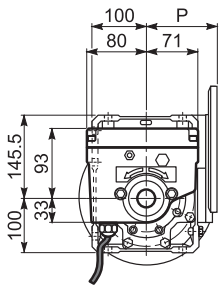

W 86 UFC

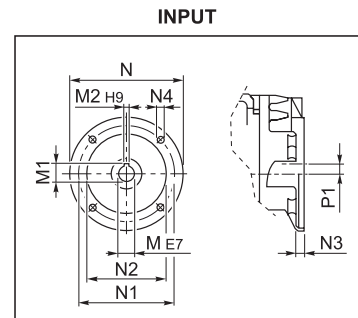
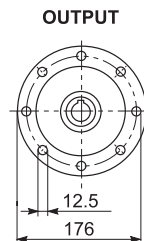
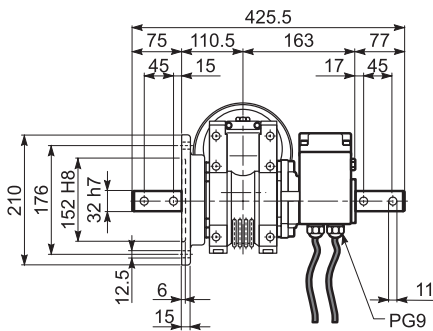
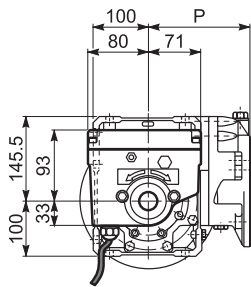

WR 86 UFC

	M	M1	M2	N	N1	N2	N3	N4	P	P1
W 86_P 71	14	16.3	5	160	130	110	11	9	128	-
W 86_P 80	19	21.8	6	200	165	130	12	11.5	128	-
W 86_P 90	24	27.3	8	200	165	130	12	11.5	128	-
WR 86_P 63	11	12.8	4	140	115	95	10	M8x10	168	35.4
WR 86_P 71	14	16.3	5	160	130	110	10	M8x10	168	35.4
WR 86_P 80	19	21.8	6	200	165	130	12	M10x13	179.5	22.9
WR 86_P 90	24	27.3	8	200	165	130	12	M10x13	179.5	22.9

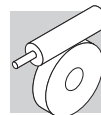

44 OPCIONES

Variante fin de carrera

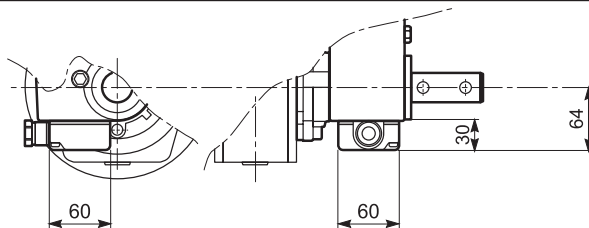
ME

Versión con caja de conexiones

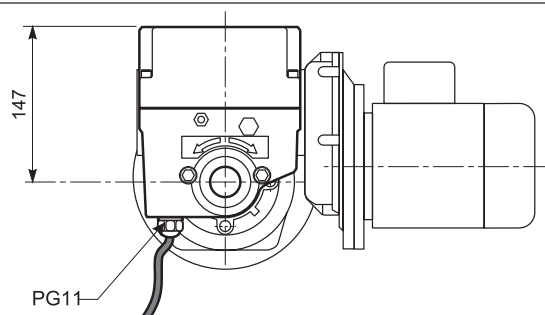
DM

Versión con doble micros



MOTORES ELÉCTRICOS

M1 SÍMBOLOS Y UNIDADES DE MEDIDA

Símbolos	Unidades de medida	Descripción	Símbolos	Unidades de medida	Descripción
$\cos\varphi$	–	Factor de potencia	n	[min ⁻¹]	Velocidad nominal
η	–	Rendimiento	P_B	[W]	Potencia absorbida por el freno a 20°C
f_m	–	Factor corrector de la potencia	P_n	[kW]	Potencia nominal
I	–	Relación de intermitencia	P_r	[kW]	Potencia requerida
I_N	[A]	Intensidad nominal	t_1	[ms]	Retardo de desbloqueo del freno con alimentación de semionda
I_S	[A]	Intensidad de arranque	t_{1s}	[ms]	Tiempo de desbloqueo del freno con alimentación con control electrónico
J_C	[Kgm ²]	Momento de inercia de la carga	t_2	[ms]	Retardo de la frenada con desconexión lado c.a.
J_M	[Kgm ²]	Momento de inercia del motor	t_{2c}	[ms]	Retardo en la frenada con desconexión circuito c.a. y c.c.
K_c	–	Factor de par	t_a	[°C]	Temperatura ambiente
K_d	–	Factor de carga	t_f	[min]	Tiempo de funcionamiento con carga constante
K_J	–	Factor de inercia	t_r	[min]	Tiempo de reposo
M_A	[Nm]	Par de aceleración medio	W	[J]	Trabajo acumulado del freno entre dos operaciones de regulación del entrehierro.
M_B	[Nm]	Par de frenado	W_{max}	[J]	Energía máxima por frenada
M_N	[Nm]	Par nominal	Z	[1/h]	Número de arranques admisibles con carga
M_L	[Nm]	Par resistente medio	Z_0	[1/h]	Número de arranques admisibles en vacío (l = 50 %)
M_S	[Nm]	Par de arranque			



M2 CARACTERÍSTICAS GENERALES

M2.1 Programa de producción

Los motores eléctricos asíncronos trifásicos del programa de producción de BONFIGLIOLI RIDUTTORI están previstos en las formas constructivas básicas IMB5, IMB14 y sus derivadas con las siguientes polaridades: 2, 4, 6, 2/4, 2/6, 2/8, 2/12. En el presente catálogo se destacan, además, las características técnicas de los motores en la versión integrada, tipo M.

M2.2 Normativa

Los motores descritos en el presente catálogo están fabricados de acuerdo con las Normas y unificaciones aplicables y relacionadas en la tabla siguiente.

(F 1)

Título	CEI	IEC
Requisitos generales para máquinas eléctricas rotativas	CEI EN 60034-1	IEC 60034-1
Identificación de terminales y sentido de giro para máquinas eléctricas rotativas	CEI 2-8	IEC 60034-8
Métodos de refrigeración de las máquinas eléctricas	CEI EN 60034-6	IEC 60034-6
Dimensiones y potencias nominales para máquinas eléctricas rotativas	EN 50347	IEC 60072
Clasificación de los grados de protección de las máquinas eléctricas rotativas	CEI EN 60034-5	IEC 60034-5
Límites de rumorosidad	CEI EN 60034-9	IEC 60034-9
Siglas de identificación de las formas constructivas y de los tipos de las instalaciones	CEI EN 60034-7	IEC 60034-7
Tensión nominal para los sistemas de distribución pública de la energía eléctrica de baja tensión	CEI 8-6	IEC 60038
Grado de vibración de las máquinas eléctricas	CEI EN 60034-14	IEC 60034-14

Los motores cumplen, además, las normas extranjeras adaptadas a las IEC 60034 -31 indicadas en la tabla.

(F 2)

DIN VDE 0530	Alemania
BS5000 / BS4999	Gran Bretaña
AS 1359	Australia
NBNC 51 - 101	Bélgica
NEK - IEC 34	Noruega
NF C 51	Francia
OEVE M 10	Austria
SEV 3009	Suiza
NEN 3173	Holanda
SS 426 01 01	Suecia

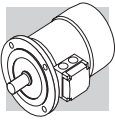

M2.3 Motores para Usa y Canada

CUS

Los motores BN están disponibles en la ejecución NEMA Diseño C (para las características eléctricas), certificados conforme a la norma CSA (Canadian Standard) C22.2 N° 100 y UL (Underwriters Laboratory) UL1004. Especificando la opción CUS, la placa de características viene marcada con los símbolos indicados a continuación.



La opción CUS, es incompatible con los motores que incorporan ventilación independiente. La tensión de las redes eléctricas americanas y la correspondiente tensión nominal que se debe especificar para el motor, están indicadas en la tabla siguiente.

(F 3)

Frecuencia	Tensión de red	V _{mot}
60 Hz	208 V	200 V
	240 V	230 V
	480 V	460 V
	600 V	575 V

La opción CUS es aplicable también a los motores de 50 Hz.

Los motores con relación de voltaje 2 (230/460-60; 220/440-60) tienen de serie 9 terminales.

Para las mismas ejecuciones y con alimentación 575V-60Hz, la potencia de la placa corresponde a la normalizada a 50Hz.

Para los motores con freno en c.c. tipo BN/M_FD la alimentación del rectificador se realiza a través de la caja de bornas del motor con tensión 230V corriente alterna monofásica.

Para los motores con freno la alimentación del freno se realiza del siguiente modo:

(F 4)

BN_FD	BN_FA	Especificación
Conectado a la caja de bornas 1~230V c.a.	Alimentación separada 230V Δ - 60Hz	230SA
	Alimentación separada 460V Y - 60Hz	460SA



M2.4 China Compulsory Certification

CCC

Los motores eléctricos destinados a ser comercializados en la Republica Popular China están afectados por la aplicación del sistema de certificación CCC (China Compulsory Certification) y motores BN con par nominal hasta 7 Nm están disponibles con certificación CCC y tarjeta especial que incluye la marca abajo indicada.



La opción ccc no está disponible para servo - motores ventilados.

M2.5 Directivas 2006/95/CE (LVD) y 2004/108/CE (EMC)

Los motores de las series BN y M cumplen los requisitos de las Directivas 2006/95/CE (Directiva de Baja Tensión) y 2004/108/CE (Directiva de Compatibilidad Electromagnética). En sus placas muestran el sello CE.

Por lo que se refiere a la Directiva EMC, la construcción de estos motores es conforme a las Normas CEI EN 60034-1, EN 61000-6-2, EN 61000-6-4.

Los motores con freno de c.c. FD, si están equipados con el correspondiente filtro capacitativo en la entrada del rectificador (opción **CF**), cumplen con los límites de emisión previstas en la Norma EN 61000-6-3:2007 "Compatibilidad electromagnética – Norma Genérica sobre emisiones – Parte 6-3: Ambientes residenciales, comerciales y de la industria ligera". Los motores cumplen, además, los requisitos de la Norma CEI EN 60204-1 "Equipamiento eléctrico de las máquinas".

Es responsabilidad del fabricante o del montador de la instalación que incorpora los motores como componentes, garantizar la seguridad y la conformidad del producto final a las directivas.

M2.6 Tolerancias

Según la Norma CEI EN 60034-1, las tolerancias admitidas para los tamaños garantizados, están indicadas en la tabla siguiente.

(F 5)	-0.15 (1 - η) P \leq 50kW	Rendimiento
	-(1 - $\cos\phi$)/6 min 0.02 max 0.07	Factor de potencia
	\pm 20% *	Deslizamiento
	+20%	Intensidad con rotor bloqueado
	-15% +25%	Par con rotor bloqueado
	-10%	Par máx.

(*) \pm 30% para motores con Pn < 1 kW



M3 CARACTERÍSTICAS MECÁNICAS

M3.1 Formas constructivas

Los motores serie BN están previstos en las formas constructivas indicadas en la tabla (F6) según la Norma CEI EN 60034-14.

Las formas constructivas son las siguientes:

IM B5 (base)

IM V1, IM V3 (variante)

IM B14 (base)

IM V18, IMV19 (variante)

Los motores de forma constructiva IM B5 pueden instalarse en las posiciones IMV1y IMV3; los motores de forma constructiva IM B14 pueden instalarse en las posiciones IMV18 y IMV19. En estos casos, en la placa del motor se indicará la forma constructiva base IM B5 o IM B14.

En las formas constructivas donde el motor está en posición vertical con el eje hacia abajo, se aconseja solicitar el sombrerete antilluvia (se tiene que prever siempre en el caso de motores- freno). Estas ejecuciones se tienen que pedir expresamente en el pedido, ya que no están previstas en la opción base.

(F 6)

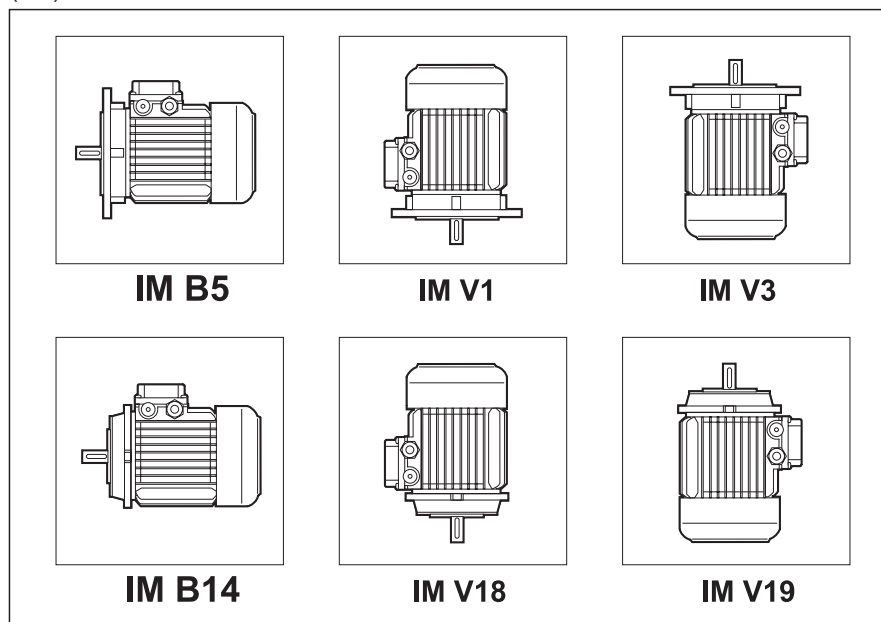

Los motores embridados pueden suministrarse con dimensiones de acoplamiento reducido, como queda indicado en la tabla - ejecuciones **B5R**, **B14R**. Su uso en combinación con los reductores debe ser coherente teniendo en cuenta la máxima potencia instalable en los mismos (ver apartado "Predisposiciones motor"). En el caso de que no se cumpla esta condición deberá contactar con el Servicio Técnico para comprobar la combinación.



(F 7)

	BN 71	BN 80	BN 90	BN 100	BN 112	BN 132
	DxE - Ø					
B5R ⁽¹⁾	11x23 - 140	14x30 - 160	19x40 - 200	24x50 - 200	24x50 - 200	28x60 - 250
B14R ⁽²⁾	11x23 - 90	14x30 - 105	19x40 - 120	24x50 - 140	—	—

(1) brida con taladros pasantes

(2) brida con taladros roscados

M3.2 Grado de protección

IP..

La tabla de abajo resume la disponibilidad de los varios grados de protección.

Independientemente del grado de protección especificado, para la instalación al aire libre, los motores deberán estar protegidos de las irradiaciones directas y, en el caso de instalación con el eje mirando hacia abajo, es necesario especificar, además, el sombrerete de protección contra la entrada de agua y cuerpos sólidos (opción **RC**)

(F 8)

		IP 54	IP 55	IP 56
BN	M		standard	
BN_FD BN_FA	M_FD M_FA	standard		

M3.3 Ventilación

Los motores están refrigerados mediante ventilación externa (C 411 según CEI EN 60034-6) y están provistos de un ventilador radial de plástico que actúa en ambos sentidos de giro.

En la instalación debe asegurarse una distancia mínima entre la tapa del ventilador y la pared, de modo que no exista impedimento a la libre circulación del aire y permitir la posibilidad del mantenimiento y, si éste está, del freno. Opcionalmente puede suministrarse la ventilación forzada independiente (opción U1). Esta solución permite aumentar el factor de utilización del motor, accionado con variador de frecuencia y a velocidad reducida.



M3.4 Sentido de giro

Es posible el funcionamiento en ambos sentidos de giro.

Conectando los bornes U1, V1, W1 a las fases de línea L1, L2, L3, el giro será en sentido horario visto por el lado del acoplamiento; el sentido de giro antihorario se obtiene invirtiendo dos de las fases.

M3.5 Rumorositad

Los valores de nivel sonoro, medidos en conformidad con el procedimiento previsto por las Normas ISO 1680, están contenidos dentro de los límites máximos previstos por las Normas CEI EN 60034-9.

M3.6 Vibraciones y equilibrado

Todos los rotores están equilibrados con media chaveta y están dentro de los límites de intensidad de vibración previstos por la Norma CEI EN 60034-14. Para exigencias particulares de baja rumorosidad, opcionalmente, está disponible una ejecución antivibrante de grado reducido B. La tabla siguiente indica los valores de velocidad eficaz de vibración para un equilibrado estándar (A) e incrementada (B).

(F 9)

Grado de vibración	Velocidad Angular n [min ⁻¹]	Límites de la velocidad de vibración [mm/s] BN 56 ≤ H ≤ BN 200 M05 ≤ H ≤ M5
A	600 < n < 3600	1.6
B	600 < n < 3600	0.70

Los valores están referidos a la medición efectuada con el motor libremente suspendido y funcionamiento en vacío.

M3.7 Caja de conexiones del motor

La caja de conexiones principal contiene seis bornes para conexionado con terminales de cable (ejecución a nueve bornes para la tensión de los Estados Unidos "Dual Voltage"). En el interior de la caja está previsto un borne para el conductor de tierra. Las dimensiones de los terminales están indicadas en la tabla siguiente. Para la alimentación del freno ver párrafo M6 (freno FD), M7 (freno FA). En los motores freno, el rectificador para la alimentación del freno está situado en el interior de la caja de bornes y provisto de los bornes adecuados para su conexionado. Efectuar el conexionado según los esquemas incluidos en el interior de la caja de bornes o en el manual de instrucciones.





(F 10)

	Nº bornes	Tamaño rosca de los terminales	Sección máxima del conductor mm ²
BE 80, BE 90 BN 56 ... BN 90	6	M4	2.5
BE 100 ... BE 132 BN 100 ... BN 160MR	6	M5	6
BE 160 BN 160M ... BN 180M	6	M6	16
BE 180 BN 180L ... BN 200L	6	M8	25

M3.8 Entrada de cables

Respetando la Norma EN 50262, los taladros de entrada de cables en la caja de bornes están realizados con rosca métrica cuya medida se indica en la tabla siguiente.

(F 11)

		Dimensión de la entrada de cable	Diámetro máximo cable conectable [mm]
BN 63	M05	2 x M20 x 1.5	13
BN 71	M1	2 x M25 x 1.5	17
BN 80 - BN 90	M2	2 x M25 x 1.5	17
BN 100	M3	2 x M32 x 1.5	21
		2 x M25 x 1.5	17
BN 112	—	2 x M32 x 1.5	21
		2 x M25 x 1.5	17
BN 132...BN 160MR	M4	4 x M32 x 1.5	21
BN 160M...BN 200L	M5	2 x M40 x 1.5	28

M3.9 Rodamientos

Los rodamientos montados son del tipo radial a bolas, con lubricación permanente y precargados Axialmente. Los tipos utilizados se indican en la siguiente tabla. La duración nominal a fatiga L_{10h} de los rodamientos, en ausencia de cargas externas aplicadas, es superior a 40.000 horas, calculadas según ISO 281.

DE = lado eje **NDE** = lado ventilador

(F 12)

	DE	NDE	
	M, M_FD, M_FA	M	M_FD, M_FA
M05	6004 2Z C3	6201 2Z C3	6201 2RS C3
M1	6004 2Z C3	6202 2Z C3	6202 2RS C3
M2	6007 2Z C3	6204 2Z C3	6204 2RS C3
M3	6207 2Z C3	6206 2Z C3	6206 2RS C3
M4	6309 2Z C3	6308 2Z C3	6308 2RS C3
M5	6309 2Z C3	6309 2Z C3	6309 2RS C3



(F 13)

	DE	NDE	
	BN	BN	BN_FD BN_FA
BN 56	6201 2Z C3	6201 2Z C3	–
BN 63	6201 2Z C3	6201 2Z C3	6201 2RS C3
BN 71	6202 2Z C3	6202 2Z C3	6202 2RS C3
BN 80	6204 2Z C3	6204 2Z C3	6204 2RS C3
BN 90	6205 2Z C3	6205 2Z C3	6305 2RS C3
BN 100	6206 2Z C3	6206 2Z C3	6206 2RS C3
BN 112	6306 2Z C3	6306 2Z C3	6306 2RS C3
BN 132	6308 2Z C3	6308 2Z C3	6308 2RS C3
BN 160MR	6309 2Z C3	6308 2Z C3	6308 2RS C3
BN 160M/L	6309 2Z C3	6309 2Z C3	6309 2RS C3
BN 180M	6310 2Z C3	6309 2Z C3	6309 2RS C3
BN 180L	6310 2Z C3	6310 2Z C3	6310 2RS C3
BN 200L	6312 2Z C3	6310 2Z C3	6310 2RS C3

M4 CARACTERÍSTICAS ELÉCTRICAS

M4.1 Tensión



Los motores de velocidad individual se proporcionan en ejecución estándar para la tensión nominal 230/400 V Δ/Y , 50 Hz, o 400 / 690 V Δ/Y , 50 Hz, con una tolerancia de tensión de $\pm 10\%$, según se especifica en la siguiente tabla.

En todos los motores BN y M, la configuración de tensión del cual no está incluida en la tabla de debajo, la tolerancia se reduce a $\pm 5\%$.

Para un funcionamiento al límite de de la tolerancia, la temperatura no debe superar en 10 K el límite previsto por la clase de aislamiento aprobado.

El motor es adecuado para su funcionamiento en la red de distribución Europea, con la tensión que cumpla la norma IEC 60038,

(F 14)

			$V_{\text{mot}} \pm 10\%$ 3 ~	Ejecución
IE1	BN 56 ... BN 132	M0 ... M4	230 / 400 V - Δ/Y - 50 Hz	Estándar
			400 / 690 V - Δ/Y - 50 Hz	A petición, sin cargo adicional
			460 V Y - 60 Hz	Estándar
	BN 160 ... 200	M5	400 / 690 V - Δ/Y - 50 Hz	Estándar
			460 V Δ - 60 Hz	Estándar

¹ Solo motores de 4 polos

Los motores de dos velocidades 50Hz, están previstos para una tensión nominal estándar de 400V; tolerancia aplicable según Norma CEI EN 60034-1

En la tabla siguiente están indicados los distintos tipos de conexionado previstos para los motores en función de la polaridad.



(F 15)





N° de polos		Conectividad de la bobina
2	BN 63 ... BN 200	$\Delta / Y^{(2)}$
4	BN 56 ... BN 200	
6	BN 63 ... BN 200	
8	BN 71 ... BN 132	
2/4	BN 63 ... BN 132	Δ / YY (Dahlander)
2/6	BN 71 ... BN 132	Y / Y (Dos bobinas)
2/8	BN 71 ... BN 132	
2/12	BN 80 ... BN 132	
4/6	BN 71 ... BN 132	
4/8	BN 80 ... BN 132	Δ / YY (Dahlander)

(²) Los motores con relacion de voltaje 2 (es. 230/460-60) estaran equipados con una conexión de terminales con 9 pines conectados $\Delta/\Delta / \Delta$ o YY / Y (excepto al BN 63 6 polos Δ / Y)

M4.2 Frecuencia

La potencia de placa de los motores BN / M a 60Hz corresponde a la indicada en la tabla siguiente.

(F 16)

		P _n [kW]						P _n [kW]			
		2P	4P	6P	8P (*)			2P	4P	6P	8P (*)
BN 56A	–	–	0.07	–	–	BN 100L	M3LA	3.5	–	–	–
BN 56B	M0B	–	0.1	–	–	BN 100LA	–	–	2.5	1.8	0.9
BN 63A	M05A	0.21	0.14	0.1	–	BN 100LB	M3LB	4.7	3.5	2.2	1.3
BN 63B	M05B	0.3	0.21	0.14	–	BN 112M	–	4.7	4.7	2.5	1.8
BN 63C	M05C	0.45	0.3	–	–	–	M3LC	–	4.7	2.5	–
BN 71A	–	0.45	0.3	0.21	0.1	BN 132S	M4SA	–	6.5	3.5	2.5
–	M1SC	–	–	0.21	–	BN 132SA	–	6.5	–	–	–
BN 71B	M05SD	0.65	0.45	0.3	0.14	BN 132SB	M4SB	8.7	–	–	–
BN 71C	M1LA	0.9	0.65	0.45	–	BN 132M	–	11	–	–	3.5
BN 80A	–	0.9	0.65	0.45	0.21	BN 132MA	M4LA	–	8.7	4.7	–
BN 80B	M2SA	1.3	0.9	0.65	0.30	BN 132MB	M4LB	–	11	6.5	–
BN 80C	M2SB	1.8	1.3	0.9	–	BN 160MR	M4LC	12.5	12.5	–	–
BN 90S	–	–	1.3	0.9	0.45	BN 160M	M5SA	–	–	8.7	–
BN 90SA	–	1.8	–	–	–	BN 160MB	–	17.5	–	–	–
BN 90SB	–	2.2	–	–	–	–	M5SB	17.5	17.5	–	–
BN 90L	M3SA	2.5	–	1.3	0.65	BN 160L	–	21.5	17.5	12.5	–
BN 90LA		–	–	1.8	–	–	M5SC	21.5	–	–	–
BN 90LB	–	–	2.2	–	–	BN 180M	M5LA	24.5	21.5	–	–
						BN 180L	–	–	25.3	17.5	–
						BN 200L	–	–	34	–	–
						BN 200LA	–	34	–	22	–

(*) Motores M_ excluidos.

Los motores BN / M de doble polaridad, alimentados a 60 Hz, tendran una potencia nominal superior, en comparacion a 50 Hz, del 15%. Cuando la etiqueta de un motor destinado a ser alimentado a 60 Hz, requiera un valor de potencia nominal de 50 Hz normalizado, deberá ser especificada la designacion PN. Los motores que normalmente trabajan a 50 Hz, se pueden utilizar en redes de 60 Hz, pero los datos tendran que ser corregidos segun la siguiente tabla.



La etiqueta de los motores designados a 50 Hz incluye los valores de operación a 60 Hz (con exclusión de los motores en ejecución CUS y motores con freno). Consulte la siguiente tabla.

(F 17)

50 Hz V - 50 Hz	60 Hz			
	V - 60 Hz	P _n - 60 Hz	M _n , M _a /M _n - 60 Hz	n [min ⁻¹] - 60 Hz
230/400 Δ/Y	220 - 240 Δ	1	0.83	1.2
	380 - 415 Y			
400/690 Δ/Y	380 - 415 Δ			
230/400 Δ/Y	265 - 280 Δ	1.15	1	1.2
	440 - 480 Y			
400/690 Δ/Y	440 - 480 Δ			

M4.3 Temperatura ambiente

Las tablas de los datos técnicos del catálogo presentan las características funcionales a 50Hz en condiciones ambientales estándar, según la Norma CEI EN 60034-1 (temperatura 40°C y altitud < 1000 m s.n.m.).

Los motores pueden emplearse a temperaturas comprendidas entre 40°C a 60°C aplicando las disminuciones de potencia indicadas en la tabla siguiente.

(F 18)

Temperatura ambiente (°C)	40°	45°	50°	55°	60°
Potencia admisible en % de la potencia nominal	100%	95%	90%	85%	80%

Cuando se precisa una disminución del motor superior del 15%, consultar con nuestro Servicio Técnico.

M4.4 Clase de aislamiento

CL F

Los motores de producción Bonfiglioli emplean, de serie, material aislante (hilo esmaltado, aislante, resina de impregnación) en clase **F**.

CL H

Bajo pedido puede suministrarse los motores con aislamiento clase **H**.

En general, para los motores de ejecución estándar, el aumento de temperatura en el bobinado del estator está comprendido dentro del límite de 80 K, correspondiente a la sobretemperatura de la clase B. La cuidadosa selección de los componentes del sistema aislante, permite el empleo de los motores incluso en climas tropicales y en presencia de vibraciones normales.

Para aplicaciones en presencia de sustancias químicas agresivas o de elevada humedad, es aconsejable contactar con nuestro Servicio Técnico para seleccionar el producto más idóneo. No disponible para los motores conformes a las normas CSA y UL (opción CUS).



(F 19)

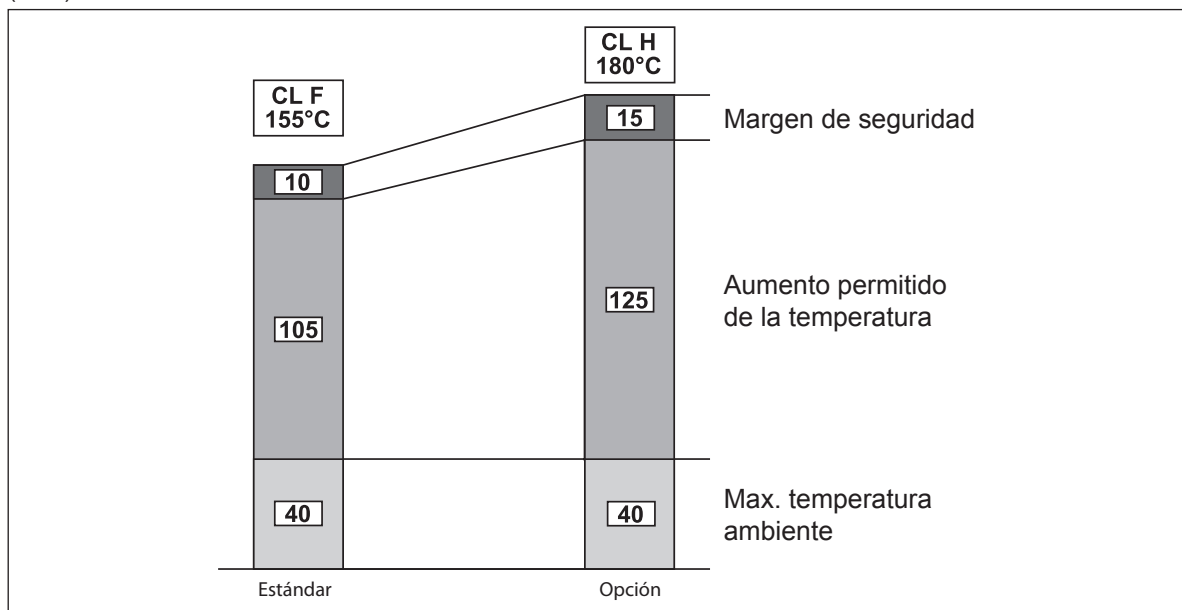

M4.5 Tipo de servicio

Si no se indica lo contrario, la potencia indicada en el catálogo se refiere al servicio continuo S1. Para los motores utilizados en condiciones distintas a S1 será necesario identificar el tipo de servicio previsto con referencia a las normas a CEI EN 60034-1. En concreto para servicio S2 y S3 es posible obtener un aumento de la potencia respecto a la prevista para servicio continuo según se indica en la siguiente tabla, válida para los motores de una sola velocidad.

Como alternativa al servicio continuo S1, en fase de configuración del producto es posible seleccionar uno de los siguientes valores: S2, S3 o S9; la placa del motor indicará una potencia aumentada en correspondencia al tipo de servicio, datos eléctricos y tipo de servicio S2-30min, S3-70% o S9, respectivamente. Para mayor información es necesario contactar con el Servicio Técnico de Bonfiglioli. Para el dimensionado de los motores de doble velocidad, consultar al Servicio Técnico de Bonfiglioli.

(F 20)

	Servicio						Contacte con nosotros
	S2			S3 *			
	Duración de vida (min)			Intermitencia (I)			
f_m	10	30 (*)	60	25%	40%	70% (*)	
	1.35	1.15	1.05	1.25	1.15	1.1	

* La duración del ciclo deberá ser igual o inferior a 10 minutos; si fuese superior consultar con nuestro Servicio Técnico.

(*) Valores predeterminados de las opciones (tab. F05).



M4.5.1 Relación de intermitencia

$$I = \frac{t_f}{t_f + t_r} \cdot 100 \quad (23)$$

t_f = tiempo de funcionamiento con carga constante

t_r = tiempo de reposo

M4.5.2 Servicio de duración limitada S2

Se caracteriza por el funcionamiento a carga constante, durante un periodo de tiempo limitado, inferior al requerido para alcanzar el equilibrio térmico, seguido de un periodo de reposo de duración suficiente para que restablezca, en el motor, la temperatura ambiente.

M4.5.3 Servicio intermitente periódico S3:

Caracterizado por una secuencia de ciclos idénticos de funcionamiento, cada uno de los cuales comprende un periodo de funcionamiento a carga constante y un periodo de reposo. En este servicio, la intensidad de arranque no influye significativamente en un aumento de la temperatura.

M4.6 Funcionamiento con variador de frecuencia

Los motores eléctricos de las series BN y M pueden ser utilizados alimentados con variador de frecuencia PWM, con tensión nominal en la entrada del variador de hasta 500V.

El sistema aislante de los motores de serie prevé el aislamiento de fase con separadores, la utilización de hilo esmaltado en grado 2 y resina de impregnación en clase H (límite de retención de la tensión punta a 1600V pico a pico enfrente de salida $t_s > 0.1 \mu s$ en bornes del motor).

En la tabla siguiente refleja las características típicas de par / velocidad, de los motores con una frecuencia base $f_b = 50$ Hz en servicio S1.

El funcionamiento con frecuencias inferiores a 30Hz, comporta la disminución del par en los motores estándar autoventilados (IC411) como resultado de la reducción originada en la ventilación, o bien como alternativa, utilizar ventilación independiente.

Para frecuencias superiores a la frecuencia base, y con la tensión máx. a la salida del variador, el motor trabaja en un campo de funcionamiento a potencia constante, en estas condiciones, el par en el eje del motor se reduce según la relación (f/f_b) .

Como el par máximo del motor decrece $(f/f_b)^2$, el margen de sobrecarga admisible deberá ser reducido gradualmente.



(F 21)

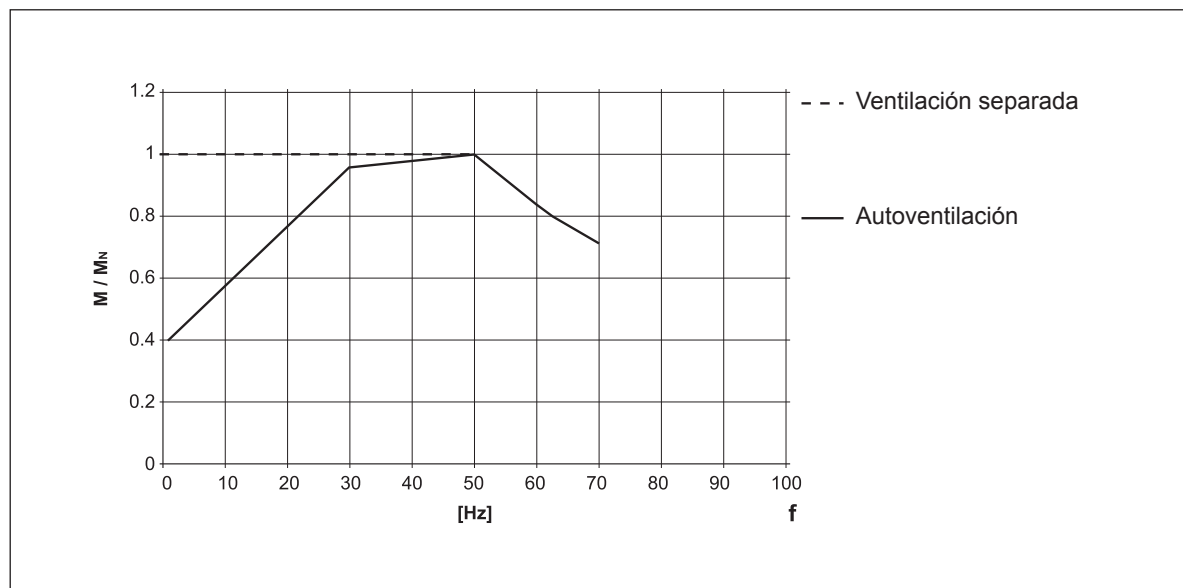

La siguiente tabla identifica el limite de velocidad mecanico para cuando se trabaja con velocidades superiores de la frecuencia nominal.

(F 22)

		n [min ⁻¹]		
		2p	4p	6p
≤ BN 112	M05...M3	5200	4000	3000
≥ BN 132	M4, M5	4500	4000	3000

A velocidades superiores a la nominal, los motores presentan mayores vibraciones mecánicas y ruidos de la ventilación; en estas aplicaciones, es aconsejable el equilibrado del rotor con grado B y eventualmente montar ventilación independiente.

Los ventiladores independientes y los frenos electromagnéticos deben de alimentarse siempre directamente de la red.

M4.7 Frecuencia máxima de arranque Z

Las tablas de los datos técnicos de los motores indican la frecuencia máxima de arranque admisible en vacío Z_0 con $I = 50\%$ correspondiente a la versión de motor freno. Este valor define el número máx. de arranques / hora en vacío que el motor puede soportar sin superar la temperatura máxima admisible por el aislamiento clase F.

En la práctica, para un motor acoplado a una carga externa con potencia absorbida P_r , inercia J_c , un par resistente durante el arranque M_L , el número de arranques admisibles se puede calcular con la siguiente fórmula:



$$Z = \frac{Z_0 \cdot K_c \cdot K_d}{K_J} \quad (24)$$

Dónde:

$K_J = \frac{J_m + J_c}{J_m}$	Factor de inercia
$K_c = \frac{M_a - M_L}{M_a}$	Factor de par
$K_d =$	Factor de carga, ver tabla inferior

(F 23)

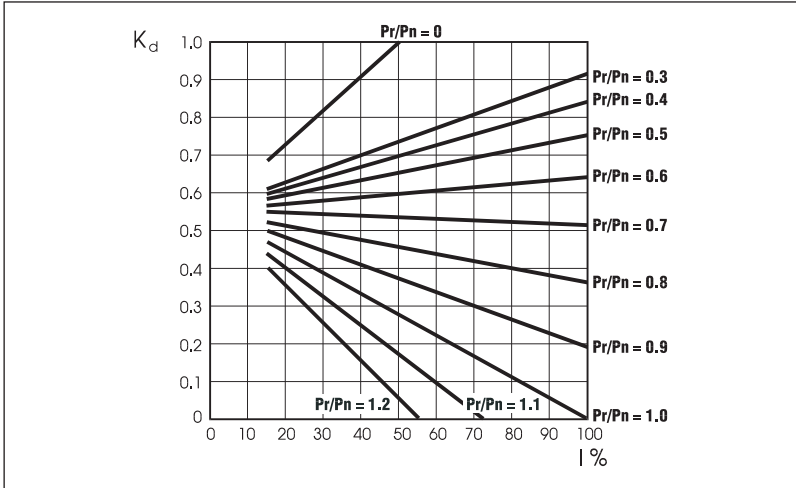

Con el número de arranques así obtenido deberá verificarse que el trabajo máximo de frenado sea compatible con la capacidad térmica del freno $W_{m\acute{a}x}$. Indicada en las tablas (F30), (F38).

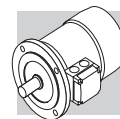

M5 MOTORES FRENO ASÍNCRONOS

M5.1 Funcionamiento

La ejecución con freno prevé el uso de frenos de presión por muelles alimentados en c.c. (tipo FD) o en c.a. (tipo FA).

Todos los frenos funcionan según el principio de seguridad, es decir, intervienen como efecto de la presión ejercida por los muelles, cuando falta la alimentación.

(F 24)

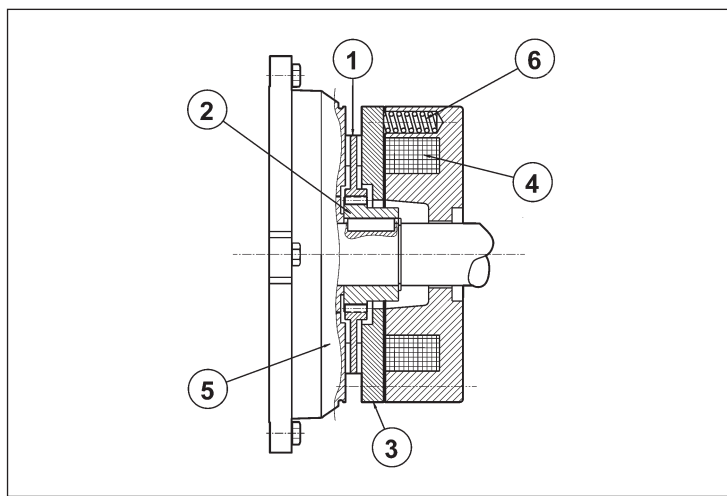

Leyenda:

- ① disco
- ② cubo
- ③ armadura móvil
- ④ bobina
- ⑤ escudo posterior motor
- ⑥ muelles

A falta de tensión, la armadura móvil, empujada por los muelles de presión, bloquea el disco de freno entre la superficie de la propia armadura móvil y el escudo del motor impidiendo el giro del eje. Cuando se excita la bobina, se produce una atracción magnética sobre la armadura móvil, que venciendo la reacción elástica de los muelles, libera el disco del freno y el eje al cual es solidario, permitiendo el giro libre del motor.

M5.2 Características generales

- Par de frenado elevado (generalmente $M_b \approx 2 M_n$) y regulable
- Disco freno con estructura de acero y doble superficie de fricción (material muy resistente al desgaste, sin amianto).
- Taladro hexagonal en el eje del motor lado ventilador (NDE), para el giro manual (no previsto cuando están presentes las opciones PS, RC, TC, U1, U2, EN1, EN2, EN3, EN4, EN5, EN6).
- Desbloqueo mecánico manual (opciones **R** y **RM** para BN/M_FD ; opción **R** para BN/M_FA).
- Tratamiento anticorrosivo sobre toda la superficie del freno.
- Aislamiento clase F.

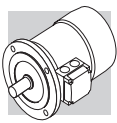

M6 MOTORES FRENO EN C.C., TIPO BN_FD y M_FD

Tamaños : BN 63 ... BN 200L / M05 ... M5

(F 25)

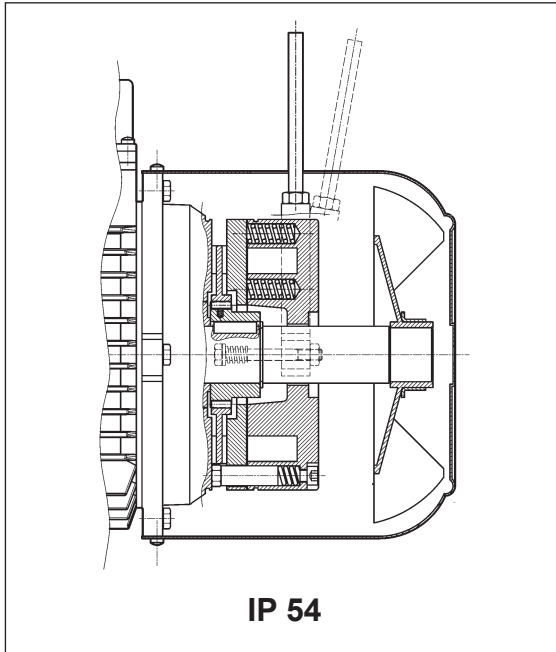

IP 54

(F 26)

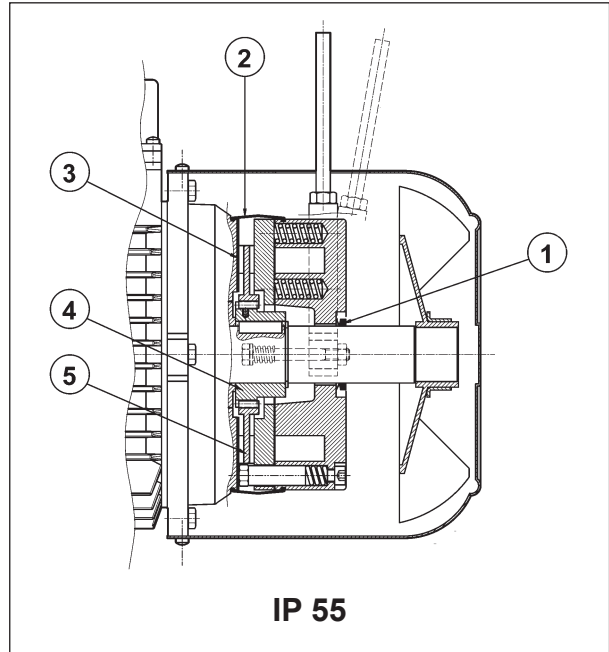

IP 55

Freno electromagnético con bobina toroidal en **corriente continua** fijado con tornillos al escudo del motor; los muelles de precarga realizan el posicionamiento axial del cuerpo magnético. El disco freno es deslizante sobre el cubo de accionamiento de acero acoplado sobre el eje y provisto de muelles antivibración. Los motores se suministran con el freno tarado en fábrica a los valores de par indicados en las tablas de datos técnicos; el par de frenado puede ser regulado modificando el tipo y/o el número de los muelles.

Bajo pedido, los motores pueden incorporar una palanca de desbloqueo manual con retorno automático (**R**) o con mantenimiento de la posición de desbloqueo freno (**RM**); para determinar la posición angular de la palanca de desbloqueo ver descripción de la variante correspondiente en el párrafo "SISTEMAS DE BLOQUEO DEL FRENO".

El freno FD garantiza elevadas prestaciones dinámicas y baja rumorosidad; las características de la intervención del freno en corriente continua pueden ser optimizadas en función de la alimentación utilizando los diferentes tipos de alimentación disponibles y/o realizando el cableado oportuno.

Para aplicaciones de elevación y/o para trabajos de mucha duración diaria, contactar con el departamento técnico comercial.

M6.1 Grado de protección

La ejecución estándar está prevista con el grado de protección IP54. Opcionalmente el motor freno tipo FD puede suministrarse con protección **IP55**, con las siguientes variantes constructivas:

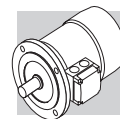

- ① retén axial V – ring montado en el eje del motor N.D.E.
- ② protección de goma impermeable al agua y al polvo
- ③ anillo de acero inox. Situado entre el escudo del motor y el disco del freno
- ④ cubo de arrastre en acero inox
- ⑤ disco freno en acero inox



M6.2 Alimentación del freno FD

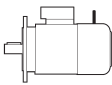

La alimentación de la bobina del freno en c.c. está prevista por medio de un rectificador apropiado, montado en el interior de la caja de bornes y cableado a la bobina del freno. Además, para los motores de simple polaridad, está prevista de serie la conexión del rectificador a los bornes del motor. Independientemente de la frecuencia de red, la tensión estándar de alimentación del rectificador V_B está indicada en la tabla siguiente:

(F 27)

2, 4, 6 P				1 speed	
		BN_FD / M_FD		alimentación del freno desde la caja de bornes	alimentación independiente
		$V_{mot} \pm 10\%$ 3 ~	$V_B \pm 10\%$ 1 ~		
BN 63...BN 132	M05...M4LB	230/400 V – 50 Hz	230 V	estándar	especificar $V_B SA$ o $V_B SD$
BN 160...BN 200	M4LC...M5	400/690 V – 50 Hz	400 V	estándar	especificar $V_B SA$ o $V_B SD$

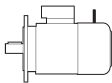

Para los motores de doble polaridad, la alimentación estándar del freno se realiza mediante una línea independiente con tensión de entrada al rectificador V_B como se indica en la tabla siguiente:

(F 28)

2/4, 2/6, 2/8, 2/12, 4/6, 4/8 P				2 speed	
		BN_FD / M_FD		alimentación del freno desde la caja de bornes	alimentación independiente
		$V_{mot} \pm 10\%$ 3 ~	$V_B \pm 10\%$ 1 ~		
BN 63...BN 132	M05...M4LB	400 V – 50 Hz	230 V		especificar $V_B SA$ o $V_B SD$

El rectificador es del tipo de diodos a semionda ($V_{c.c} \approx 0,45 \times V_{c.a.}$) y está disponible en las versiones **NB**, **SB**, **NBR** y **SBR**, como se detalla en la tabla siguiente:

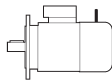
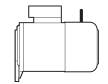
(F 29)

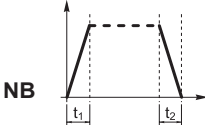
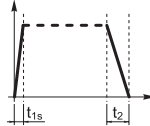
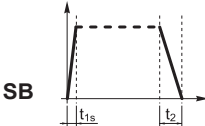
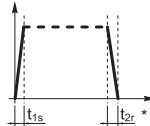
		freno		
			estándar	bajo pedido
BN 63	M05	FD 02		
BN 71	M1	FD 03 FD 53		
BN 80	M2	FD 04		
BN 90S	—	FD 14		
BN 90L	—	FD 05		
BN 100	M3	FD 15		
—	—	FD 55		
BN 112	—	FD 06S		
BN 132 - BN 160MR	M4	FD 56 FD 06 FD 07		
BN 160L - BN 180M	M5	FD 08		
BN 180L - BN 200M	—	FD 09		

(*) $t_{2c} < t_{2r} < t_2$

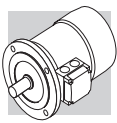

El rectificador **SB** con la excitación controlada electrónicamente, reduce los tiempos de desbloqueo del freno sobreexcitando el electroimán en los primeros instantes de la inserción, pasando seguidamente al funcionamiento normal de semionda una vez se ha desactivado el freno.

El uso del rectificador tipo **SB** debe preverse siempre en los casos siguientes:

- elevado número de arranques por hora
- tiempos de desbloqueo del freno reducidos
- elevadas sollicitaciones térmicas del freno

Para aquellas aplicaciones donde se requiere una intervención (recuperación de las condiciones de frenado) rápido del freno, pueden suministrarse bajo pedido los rectificadores **NBR** o **SBR**.

Estos rectificadores completan los tipos **NB** y **SB**, integrando en el circuito electrónico un interruptor estático que interviene desactivando rápidamente el freno en el caso de falta de tensión.

Esta solución permite reducir el tiempo de desbloqueo del freno evitando ulteriores cableados y contactos externos. Para un mejor uso de los rectificadores **NBR** y **SBR** es necesario efectuar la alimentación del freno independiente.

Tensiones disponibles: 230Vac ±10%, 400V ±10%, 50/60 Hz (con rectificador); 100Vdc ±10%, 180Vdc ±10% (con opciónSD).

M6.3 Datos técnicos del freno FD

En la tabla siguiente se indican las características técnicas de los frenos en c.c. tipo FD.

(F 30)

Freno	Par de frenado M_b [Nm]			Desbloqueo		Frenada		W_{max} por frenada			W	P
	muelles			t_1	t_{1s}	t_2	t_{2c}	[J]				
	6	4	2	[ms]	[ms]	[ms]	[ms]	10 s/h	100 s/h	1000 s/h	[MJ]	[W]
FD02	–	3.5	1.75	30	15	80	9	4500	1400	180	15	17
FD03	5	3.5	1.75	50	20	100	12	7000	1900	230	25	24
FD53	7.5	5	2.5	60	30	100	12					
FD04	15	10	5	80	35	140	15	10000	3100	350	30	33
FD14												
FD05	40	26	13	130	65	170	20	18000	4500	500	50	45
FD15	40	26	13	130	65	170	20					
FD55	55	37	18	–	65	170	20					
FD06S	60	40	20	–	80	220	25	20000	4800	550	70	55
FD56	–	75	37	–	90	250	20	29000	7400	800	80	65
FD06		100	50		100	250	20					
FD07	150	100	50	–	120	200	25	40000	9300	1000	130	65
FD08*	250	200	170	–	140	350	30	60000	14000	1500	230	100
FD09**	400	300	200	–	200	450	40	70000	15000	1700	230	120

* valores de par de frenado con 9, 7 y 6 muelles respectivamente.

** valores de par de frenado con 12, 9 y 6 muelles respectivamente.

- t_1 = tiempos de desbloqueo del freno con alimentador de semionda
- t_{1s} = tiempos de desbloqueo del freno con dispositivo con alimentador de la excitación a control electrónico
- t_2 = retardo de la frenada con interrupción lado c.a. y alimentación independiente
- t_{2c} = retardo de la frenada con interrupción lado c.a. y c.c. – Los valores t_1 , t_{1s} , t_2 , t_{2c} indicados en la tabla se refieren al freno tarado al par máximo, entrehierro medio y tensión nominal
- W_{max} = energía máxima por frenada
- W = energía de frenada entre dos regulaciones sucesivas del entrehierro
- P_b = potencia absorbida por el freno a 20°C
- M_b = par de frenado estático (±15%)
- s/h = arranques hora

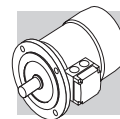

El desgaste del ferodo depende de las condiciones de trabajo (temperatura, humedad, velocidad de deslizamientos, presión específica); los valores de desgaste deben de considerarse como indicativas.

M6.4 Conexiones del freno FD

Los motores estándar de una velocidad, se suministran con la conexión del rectificador a la caja de bornes realizada en fábrica.

Para los motores de 2 velocidades, y donde se requiera la alimentación independiente del freno, prever la conexión al rectificador de acuerdo con la tensión del freno VB indicada en la placa del motor.

Dada la naturaleza inductiva de la carga, para el mando del freno y para la interrupción lado corriente continua, deben utilizarse contactos con categoría de uso AC-3 según IEC 60947-4-1.

Tabla (F31) - Alimentación del freno desde los bornes del motor e interrupción lado c.a.

Tiempo de parada t_2 retardado en función de las constantes de tiempo del motor. Debe preverse cuando se requieran arranques/ paradas progresivos.

Tabla (F32) - Bobina del freno con alimentación independiente e interrupción del lado c.a.

Tiempo de parada normal e independiente del motor.

Los tiempos de paro t_2 están indicados en la tabla (F30).

Tabla (F33) - Bobina freno con alimentación independiente e interrupción del lado c.a. y c.c.

Tiempo de parada reducido según los valores t_{2c} indicados en la tabla (F30).

Tabla (F34) - Bobina de freno con alimentación separada e interrupción lado c.a. y c.c.

Tiempo de parada reducido según los valores t_{2c} indicados en la tabla (F30).

La alimentación del freno directamente desde el terminal del motor (de la tabla F31 a la tabla F34) solo es posible cuando la tensión nominal de freno corresponde a la tensión baja del motor.

(F 31)

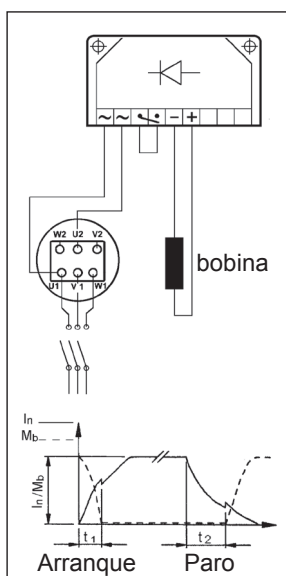

(F 32)

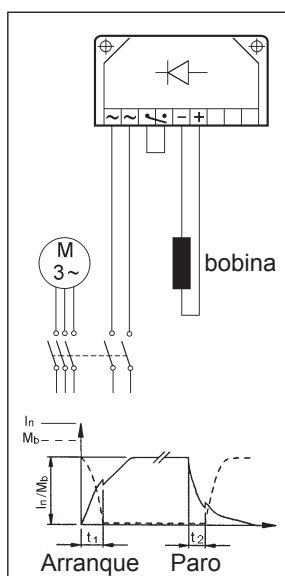

(F 33)

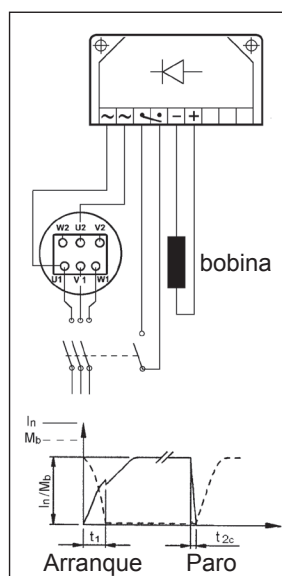

(F 34)

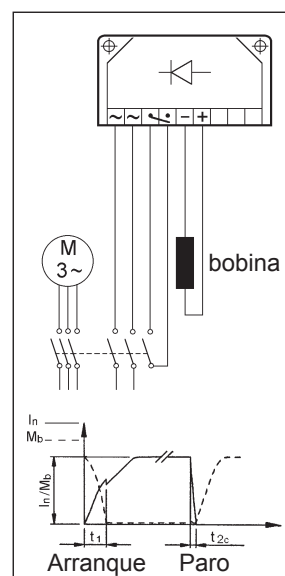

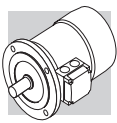

M7 MOTORES FRENO DE C.A., TIPO BN_FA y M_FA

Tamaños: BN 63 ... BN 180M / M05 ... M5

(F 35)

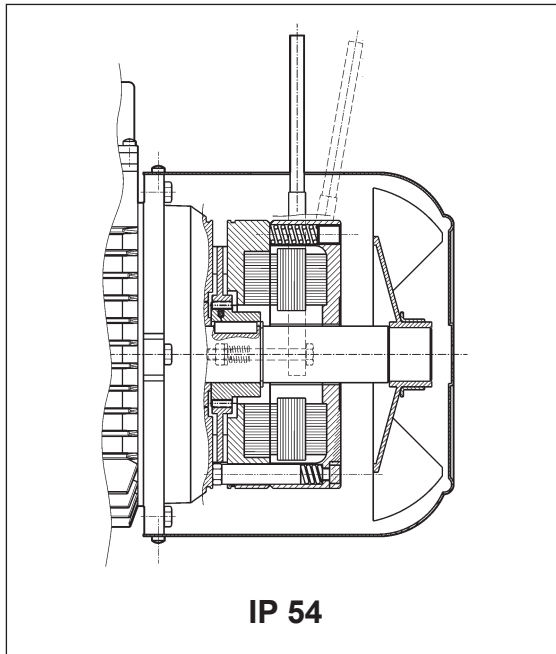

(F 36)

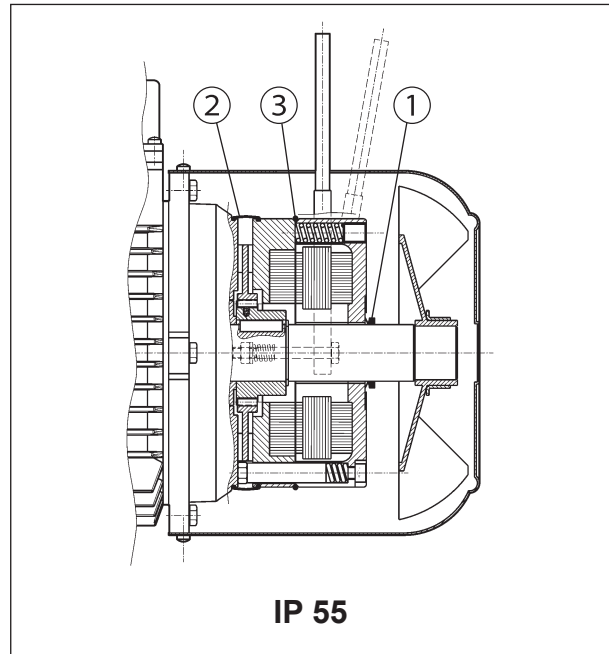

Freno electromagnético alimentado con corriente corriente alterna trifásica, fijado con tornillos al escudo del motor; los muelles de precarga efectúan el posicionamiento axial del cuerpo magnético. El disco freno es deslizable axialmente sobre el cubo de accionamiento en acero, acoplado sobre el eje y provisto de muelles antivibración. El par de frenado viene regulado de fábrica con los valores que se indican en las tablas de características técnicas de los motores correspondientes. La acción del freno también es ajustable, regulando gradualmente el par de frenado a través del tornillo que realiza la precarga de los muelles; el campo de regulación del par es: $30\% M_{bMAX} < M_b < M_{bMAX}$ (M_{bMAX} es el momento de frenado máximo indicado en la tabla (F38).

El freno tipo FA presenta unas características dinámicas muy elevadas que lo hacen idóneo en aplicaciones donde se requieren frecuencias de arranque elevadas con tiempos de intervención muy rápidos.

Bajo pedido, los motores pueden ser equipados con palanca para el desbloqueo manual con retorno automático (R). Para la especificar la posición angular de la palanca, ver la variante en el párrafo "SISTEMAS DE DESBLOQUEO DEL FRENO".

Para aplicaciones de elevación y/o elevada disipación de energía diaria, contactar con el servicio técnico comercial

M7.1 Grado de protección

En la ejecución estándar está previsto el grado de protección IP54. Como opción, el motor freno FA puede suministrarse con grado de protección **IP55** comportando las siguientes variantes constructivas.

- ① retén axial V – ring montado en el eje del motor N.D.E.
- ② protección de goma impermeable al agua y al polvo
- ③ junta tórica

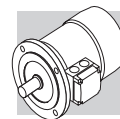

M7.2 Alimentación del freno FA

En los motores de polaridad simple, la alimentación de la bobina del freno está conectada directamente en los bornes del motor, por tanto, la tensión del freno coincide con la tensión del motor. En este caso la tensión del freno puede ser omitida en la designación.

Para los motores de doble polaridad, y también para los motores con alimentación independiente del freno, existe una caja de bornes auxiliar con 6 terminales para la conexión del freno a la línea. En ambos casos el valor de la tensión del freno deberá especificarse en la designación.

En la tabla siguiente se indican los valores de la alimentación estándar del freno en c.a. Para los motores de simple o doble Polaridad.

(F 37)

Motores de una sola velocidad	BN 63...BN 132	BN 160...BN 180
	M05...M4LB	M4LC...M5
	230Δ / 400Y V ±10% – 50 Hz	400Δ/ 690Y V ±10% – 50 Hz
	265Δ / 460Y ±10% - 60 Hz	460Y – 60 Hz
Motor de doble velocidad (alimentación de línea independiente)	BN 63...BN 132	
	M05...M4	
	230Δ / 400Y V ±10% – 50 Hz	
	460Y - 60 Hz	

Si no se especifica otra distinta, la alimentación estándar del freno es de 230Δ / 400 Y V. 50Hz.

Bajo pedido, pueden suministrarse tensiones especiales en el rango 24...690 V, 50-60 Hz.

M7.3 Datos técnicos frenos FA

(F 38)

Freno	Par de frenado M_b [Nm]	Desbloqueo t_1 [ms]	Frenada t_2 [ms]	W_{max} [J]			W [MJ]	P [VA]
				10 s/h	100 s/h	1000 s/h		
FA 02	3.5	4	20	4500	1400	180	15	60
FA 03	7.5	4	40	7000	1900	230	25	80
FA 04	15	6	60	10000	3100	350	30	110
FA 14								
FA 05	40	8	90	18000	4500	500	50	250
FA 15								
FA 06S	60	16	120	20000	4800	550	70	470
FA 06	75	16	140	29000	7400	800	80	550
FA 07	150	16	180	40000	9300	1000	130	600
FA 08	250	20	200	60000	14000	1500	230	1200

M_b = par de frenado estático ($\pm 15\%$)
 t_1 = tiempo de desbloqueo del freno
 t_2 = retardo de la frenada
 W_{max} = energía máx. por frenada (capacidad térmica del freno)
W = energía de frenado entre dos regulaciones sucesivas del entrehierro
 P_b = potencia absorbida por el freno a 20° (50 Hz)
s/h = arranques hora

NOTA.
Los valores de t_1 y t_2 indicados en la tabla están referidos al valor del freno regulado en par, entrehierro medio y tensión nominales

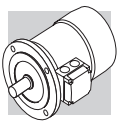

El desgaste del ferodo depende de las condiciones de trabajo (temperatura, humedad, velocidad de deslizamientos, presión específica); los valores de desgaste deben de considerarse como indicativas.

M7.4 Conexiones del freno FA

Para los motores con la alimentación del freno efectuada directamente desde la alimentación del motor, las conexiones a la caja de bornes corresponden a las indicaciones del esquema siguiente:

(F 39)

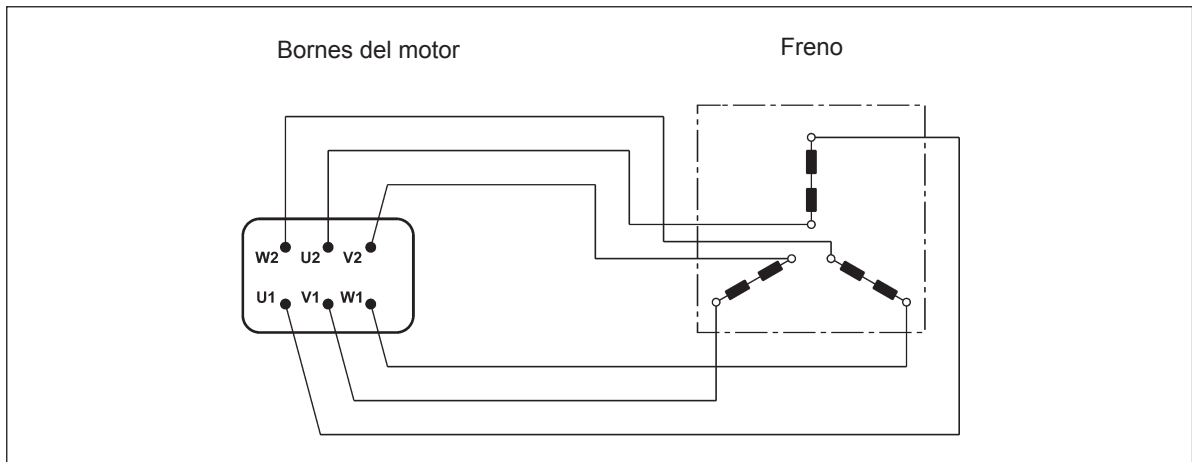

Para los motores de doble polaridad, y cuando se requiera, los motores de una velocidad con alimentación independiente, está prevista una regleta auxiliar con 6 bornes para la conexión del freno; en esta ejecución los motores incorporan una caja de bornes mayor. Ver esquema siguiente:

(F 40)

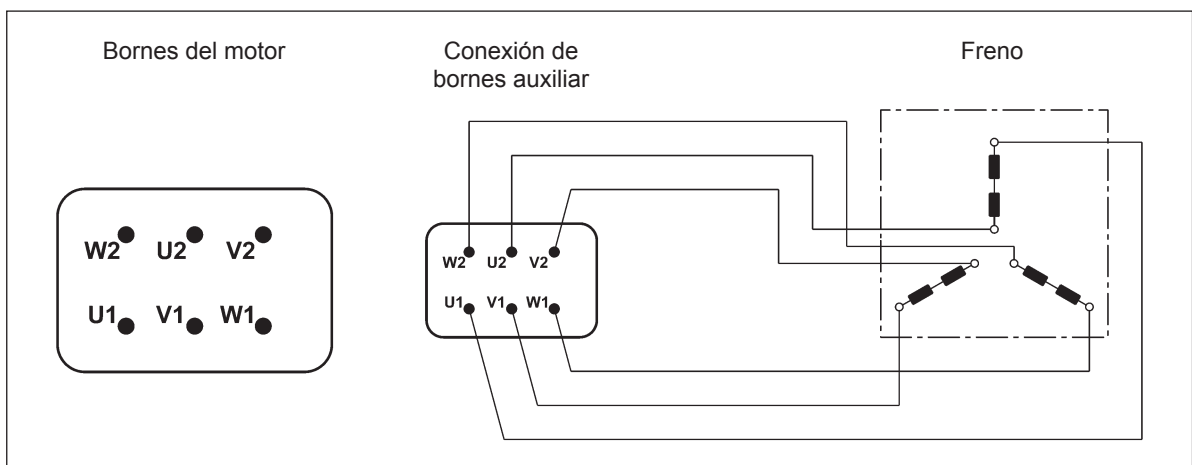

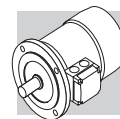

M8 SISTEMA DE DESBLOQUEO DEL FRENO

Los frenos por presión de muelles tipo FD y FA pueden dotarse opcionalmente de dispositivos para el desbloqueo manual del freno, normalmente utilizados para efectuar intervenciones de mantenimiento sobre los componentes de la máquina, o de la instalación, accionados por el Motor.

(F 41)

R

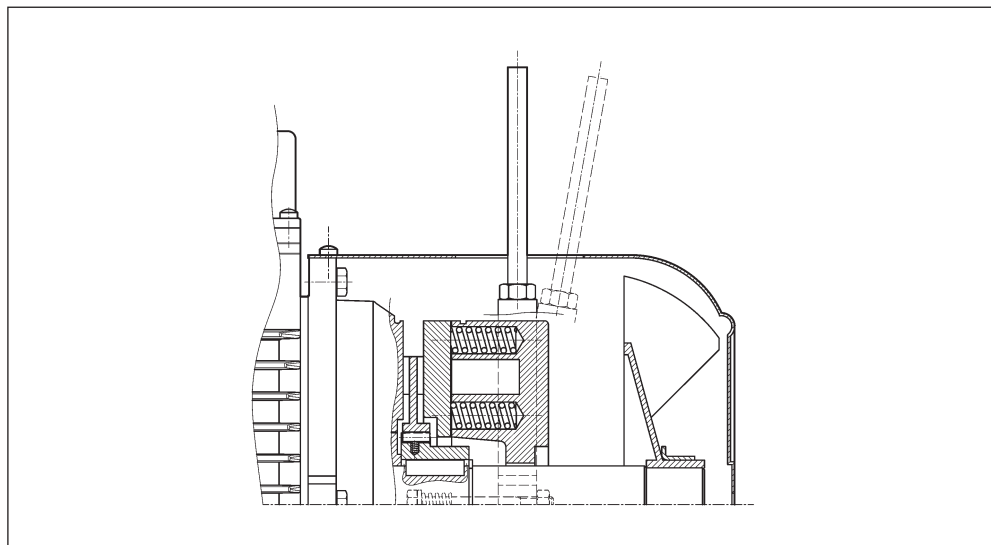

La palanca de desbloqueo incorpora el retorno automático a través de un dispositivo demuelles.

(F 42)

RM

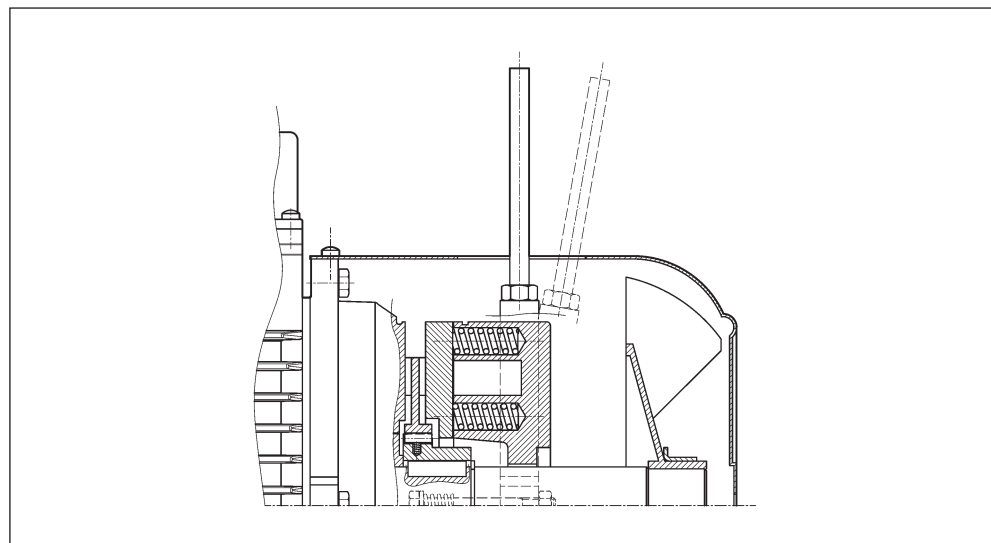

En los motores BN_FD la palanca de desbloqueo puede fijarse temporalmente en posición de desbloqueo del freno, ajustando la misma hasta sujetar la extremidad en un resalte del cuerpo del freno.

La disponibilidad de los sistemas de desbloqueo del freno es distinta para los diversos tipos de motor, y se describe en la tabla siguiente:

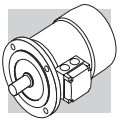

(F 43)

	R	RM
BN_FD	BN 63...BN 200	2p 63A2 ≤ H ≤ 132M2 4p 63A4 ≤ H ≤ 132MA4 6p 63A6 ≤ H ≤ 132MA6
M_FD	M 05...M 5	M 05...M 4LA
BN_FA	BN 63...BN 180M	⊖
M_FA	M 05...M 5	

M8.1 Orientación de la palanca de desbloqueo

Para las dos opciones **R** y **RM**, si no se especifica lo contrario, la palanca de desbloqueo del freno viene situada con orientación de 90° en sentido horario, respecto a la posición de la caja de bornes - referencia **[AB]** en el dibujo de abajo.

Orientaciones alternativas, tipo **[AA]**, **[AC]** y **[AD]** se pueden solicitar citando la especificación correspondiente:

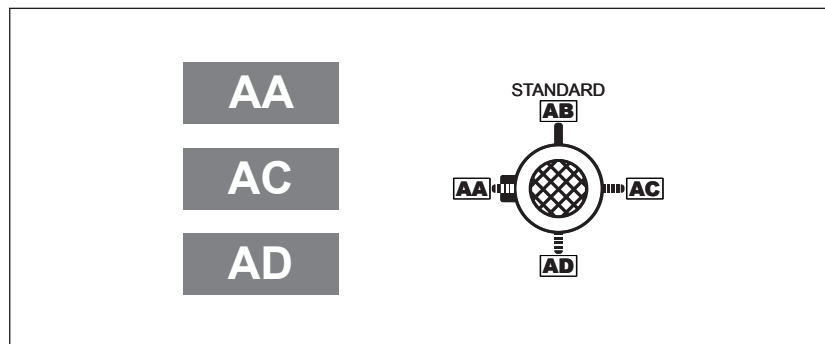

(F 44)



M8.2 Características de los volantes de inercia (F1)

En la siguiente tabla se detallan el peso y la inercia suplementaria del volante que puede ser solicitado con la opción F1. Las dimensiones generales del motor permanecen invariables.

(F 45)

Datos técnicos del volante para motores tipo: BN_FD			
		Peso del volante [Kg]	Inercia del volante [Kgm ²]
BN 63	M05	0.69	0.00063
BN 71	M1	1.13	0.00135
BN 80	M2	1.67	0.00270
BN 90 S - BN 90 L	–	2.51	0.00530
BN 100	M3	3.48	0.00840
BN 112	–	4.82	0.01483
BN 132 S - BN 132 M	M4	6.19	0.02580

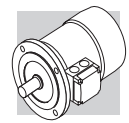

M9 OPCIONES

M9.1 Protecciones térmicas

Además de la protección garantizada por el interruptor magnetotérmico, los motores pueden ser equipados con sondas térmicas incorporadas, para proteger al bobinado contra las excesivas temperaturas producidas por una ventilación insuficiente o a un servicio intermitente. Esta protección debería estar siempre prevista para motores con ventilación independiente (IC416).

M9.2 Filtro capacitativo

CF

Hay disponible un filtro capacitativo solo para motores con freno tipo BN_FD. Cuando el filtro capacitativo adecuado es instalado en el rectificador (Opción CF), los motores cumplen con los límites de emisiones establecido por la norma EN61000-6-3:2007 Compatibilidad Electromagnética - Emisiones Genéricas Estándar - Parte 6-3: Doméstico, comercial y luz industrial medioambiental.

M9.3 Sonda térmica de termistores

E3

Los termistores son semiconductores que presentan una rápida variación de su resistencia cuando se aproxima a la temperatura nominal de actuación (150 °C).

La evolución de la característica $R = f(T)$ está definida por las normas DIN 440811, IEC 34-11

Estos sensores presentan la ventaja de tener unas dimensiones reducidas, una respuesta muy rápida y dado que el funcionamiento se realiza sin contactos, están completamente libres de desgaste.

En general, se utilizan termistores con coeficientes de temperatura positivos, también denominados "resistores de conductor frío" PTC. A diferencia de las sondas térmicas bimetálicas, no pueden intervenir directamente en la corriente de las bobinas de excitación y deben, por tanto, conectarse a una unidad especial de control (elemento de desconexión) que intercepte la conexión externa.

Con esta protección se instalan tres PTC (conectadas en serie) en el bobinado con los terminales situados en una caja de bornes Auxiliar.

K1

Son un subgrupo de termistores PTC las características constructivas de los cuales permiten la función como sensores de temperatura teniendo un coeficiente de temperatura positivo en función de la resistencia. La temperatura de trabajo es: 0°C...+260°C.

Los termistores no pueden comandar directamente los relés y deben por tanto ser conectados a un adecuado sistema de desenganche.

Los terminales (polarizados) de n.1 KTY 84-130 están disponibles en una caja de bornas auxiliar.

M9.4 Sondas térmicas bimetálicas

D3

Los protectores de este tipo contienen en su interior un disco metálico que, al alcanzar la temperatura nominal de intervención (150 °C), conmuta los contactos desde la posición de reposo.

Al disminuir la temperatura, el disco y los contactos retornan automáticamente a la posición de reposo. Normalmente se emplean tres sondas bimetálicas conectadas en serie con contactos normalmente cerrados y los terminales situados en una caja de bornes auxiliar.

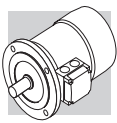

M9.5 Motor con conector

CON

Hay disponibles tres tipos de conector (CON 1, CON 2, CON 3) que pueden instalarse en dos posiciones de montaje: lado derecho de la caja de bornas (C1D, C2D, C3D); lado izquierdo caja de bornas (C1S, C2S, C3S).

L'opción CON está prevista para los motores BN M y una sola polarida (2, 4, 6, 8, polos) y en los tamaños indicados en la siguiente tablan. Quedan excluidas todas las versiones con doble polaridad. Los conectores están disponibles para los motores BN y M en la versión sin freno y para los motores con freno BN y M con freno en corriente continua FD, en los tamaños indicados en la siguiente tabla.

Sobre el motor se fija el conector macho (von pin), el conector hembra no se suministra, Con la opción CON siempre está prevista la conexión de las fases en Y.

Para los motores con servoventilación (opción U1) la alimentación el ventilador está prevista en una caja de bornas separada y fijado sobre la tapa del ventilador.

En los motores con encoder (opciones EN1...EN6) los terminales de la conexión del encoder se realiza a través del cable volante no conectado al conector.

La opción CON no se aplica a los motores con freno en corriente alterna FA.

La opción CON no es compatible con las opciones U2, CUS, IC

Datos técnicos

(F 46)

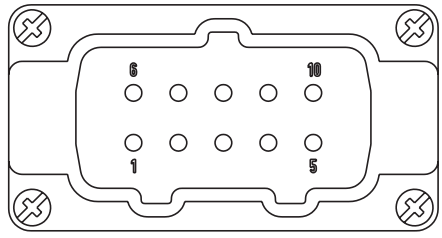
Opción	CON 1
Tamaño motor	BN63...BN112 / M05...M3
Vista conector	
Tipo de conector	Harting Han 10ES
Cuerpo conector	Han EMC 10B con 2 levass
Número de pins - corriente normal	10 x 16A
Tensión de alimentación	500 Vac
Tipo de conexión contactos	Terminales con tornillo

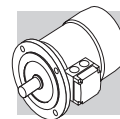

(F 47)

Opción	CON 2
Tamaño motor	BN63...BN160MR / M05...M4L
Vista conector	
Tipo de conector	Harting Han Modular
Cuerpo conector	Han EMC 10B con 2 levas
Tipo Modulo	Modulo C + Modulo vacío + Modulo E
Número de pins - corriente normal	3 x 36A / 6 x 16A
Tensión de alimentación	500 Vac
Tipo de conexión contactos	Contactos a crimpar

(F 48)

Opción	CON 3
Tamaño motor	BN63...BN160M / M05...M4L
Vista conector	
Tipo de conector	Harting Han Modular
Cuerpo conector	Han EMC 10B con 2 levas
Tipo Modulo	Modulo C + Modulo vacío + Modulo E
Número de pins - corriente normal	3 x 36A / 6 + 6 x 16A
Tensión de alimentación	500 Vac
Tipo de conexión contactos	Contactos a crimpar

(F 49)

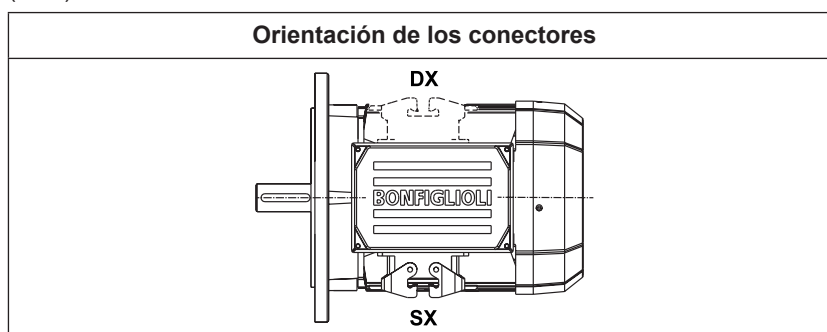

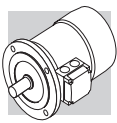

(F 50)

Diseño de dimensiones motores sin freno						
		AD (mm)	AF (mm)	AH (mm)	LL (mm)	V ^(*) (mm)
BN63	M05	136	110	45	165	4.5
BN71	M1	149	110	45	165	15.5
BN80	M2	160	110	45	165	16.5
BN90	—	162	110	45	165	31.5
BN100	M3	171	110	45	165	37.5
BN112	—	186	110	45	165	39
BN132	M4	210	140	45	188	45.5
BN160MR	—	210	140	45	188	161

(*) dimensiones referite ai soli motori BN.

(F 51)

Diseño de dimensiones motores con freno FD						
		AD (mm)	AF (mm)	AH (mm)	LL (mm)	V ^(*) (mm)
BN63	M05	136	110	45	165	4.5
BN71	M1	149	110	45	165	15.5
BN80	M2	160	110	45	165	16.5
BN90	—	162	110	45	165	31.5
BN100	M3	171	110	45	165	37.5
BN112	—	186	110	45	165	39
BN132	M4	210	140	45	188	45.5
BN160MR	—	210	140	45	188	161

(*) las dimensiones se refieren únicamente a los motores BN.

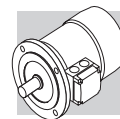

M9.6 Control de la funcionalidad de freno

MSW

El microinterruptor puede ser regulado para indicar la atracción/liberación del ánclora móvil o para señalar que se ha llegado al valor máximo admisible del entrehierro.

La opción MSW está disponible para los freno FD03...FD09.

El microswitch tiene tres terminales NC, NO, COM. En la sigura de abajo, vienen indicados los principales componentes del freno equipado con microswitch.

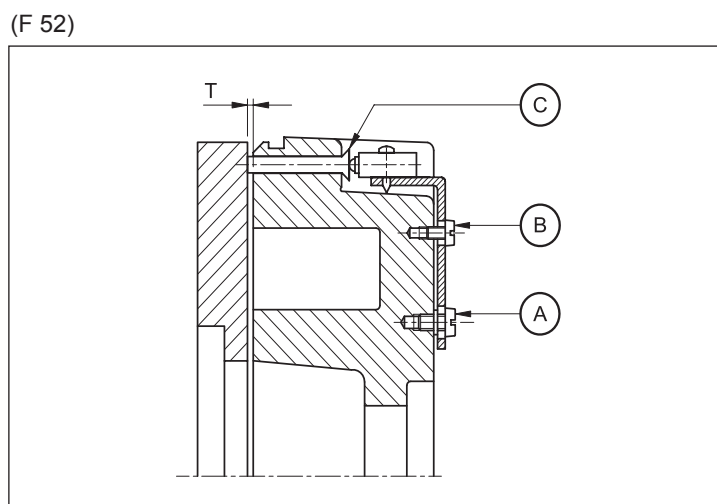

- A: Tornillo de fijación
- B: Tornillo de regulación
- C: Actuador

M9.7 Entrada de cables suplementarios para motores autofrenantes

IC

En la tapa de la caja de bornas de los motores freno BN63...BN160MR / M05...M4 están disponibles dos entradas adicionales para cables M16 x 1.5 (uno por cada lado).

En la tapa de la caja de bornas de los motores freno BN160...BN200 / M5 está disponible una entrada para cable de M16 x 1.5 al lado de la entrada del cable del freno.

M9.8 Resistencias anticondensación

H1

NH1

Los motores funcionando en ambientes muy húmedos y/o con grandes variaciones de temperatura, pueden equiparse con una resistencia de caldeo (anticondensación).

La alimentación monofásica se realiza mediante un una regleta auxiliar situada en la caja principal.

La potencia absorbida por la resistencia eléctrica, está indicada en la lista siguiente:

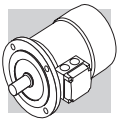

(F 53)

		H1	NH1
		1~ 230V ± 10% P [W]	1~ 115V ± 10% P [W]
BN 56...BN 80	M0...M2	10	10
BN 90...BN 160MR	M3 - M4	25	25
BN 160M...BN 180M	M5	50	50
BN 180L...BN 200L	—		

Importante! Durante el funcionamiento del motor, la resistencia de caldeo nunca debe permanecer alimentada.

M9.9 Tropicalización

TP

Cuando se especifica la opción TP, la bobina del motor recibe una protección adicional para su funcionamiento en unas condiciones de elevada humedad y temperatura,

M9.10 Segunda extremidad del eje

PS

Esta opción excluye las opciones RC, TC, U1, U2, EN1, EN2, EN3, EN4, EN5, EN6. Las dimensiones pueden obtenerse en la tabla de dimensiones de los motores.

(F 54)

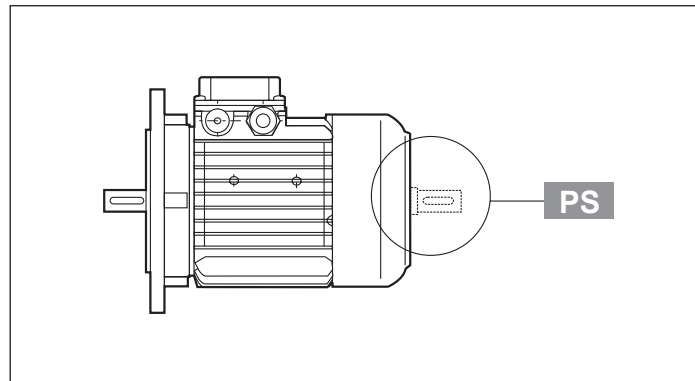

M9.11 Dispositivo antirretorno

AL

AR

En las aplicaciones donde sea necesario impedir el giro inverso del motor motivado por la carga, es posible emplear motores provistos de un dispositivo antirretorno (solamente disponible en los motores serie M). Este dispositivo permite el giro libre en el sentido de marcha, interviniendo instantáneamente en ausencia de la corriente bloqueando el giro del eje en el sentido inverso.

El dispositivo antirretorno está lubricado de por vida con grasa específica para esta aplicación.

En el momento del pedido deberá indicarse con claridad el sentido de giro previsto.

En ningún caso, el dispositivo antirretorno, deberá utilizarse para impedir el giro inverso en caso de conexión eléctrica errónea. En la tabla (F55) están indicados los valores del par nominal y máximo de retención, aplicable al dispositivo antirretorno utilizado, la representación esquemática del dispositivo se muestra en la tabla (F56).

Las dimensiones son las mismas que las del motor freno. El sentido de giro libre está descrito en el párrafo "OPCIONES MOTORES" para cada sección dedicadas a los reductores.

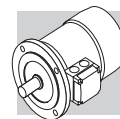

(F 55)

	Par nominal de bloqueo	Par máx. de bloqueo	Velocidad de liberación
	[Nm]	[Nm]	[min ⁻¹]
M1	6	10	750
M2	16	27	650
M3	54	92	520
M4	110	205	430

(F 56)

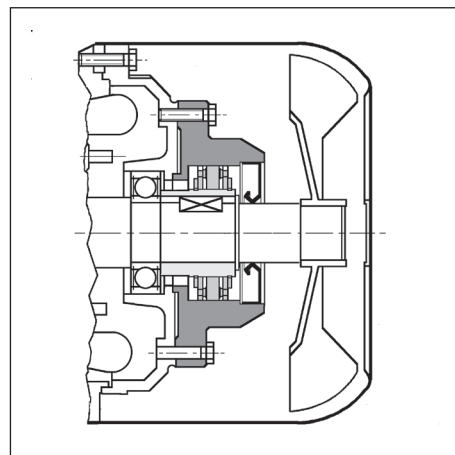

M9.12 Ventilación

Los motores están refrigerados mediante ventilación externa (IC 411 según CEI EN 60034-6) y están equipados con un ventilador radial de plástico que funciona en ambos sentidos de giro. En la instalación deberá asegurarse una distancia mínima entre la tapa del ventilador y la pared más cercana, de modo que se asegure una buena circulación del aire y permita realizar el mantenimiento oportuno del motor y, si lo lleva, el del freno.



Bajo pedido, y a partir del tamaño BN 71, o bien M1, los motores pueden suministrarse con ventilación y alimentación independientes.

La refrigeración se realiza mediante un ventilador axial, con alimentación independiente, montado sobre la tapa del ventilador (método de enfriamiento IC 416).

Esta ejecución es utilizada cuando el motor es alimentado mediante variador de frecuencia, con objeto de ampliar el campo de funcionamiento del motor a par constante, incluso a baja velocidad o cuando está solicitado con frecuencias de arranque elevadas.

Quedan excluidos de esta opción los todos los motores con doble eje (opción PS)



(F 57)

Datos de alimentación					
		V a.c. ± 10%	Hz	P [W]	I [A]
BN 71	M1	1~ 230	50 / 60	22	0.12
BN 80	M2			22	0.12
BN 90	—			40	0.30
BN 100 (*)	M3			50	0.25
BN 112	—	3~ 230 Δ / 400Y		50	0.26 / 0.15
BN 132S	M4S		110	0.38 / 0.22	
BN 132M...BN 160MR	M4L				
BN 160...BN 180M	M5				50

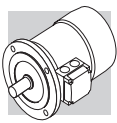
Para esta variante, están disponibles dos ejecuciones alternativas, denominadas **U1** y **U2**, que tienen la misma dimensión en el sentido longitudinal. Para ambas ejecuciones, el incremento de longitud de la tapa del ventilador (**ΔL**) está indicado en la tabla siguiente. Las dimensiones generales se obtienen de las tablas dimensionales de los motores.



(F 58)

Tabla del incremento de la longitud del motor			
		ΔL_1	ΔL_2
BN 71	M1	93	32
BN 80	M2	127	55
BN 90	—	131	48
BN 100	M3	119	28
BN 112	—	130	31
BN 132S	M4S	161	51
BN 132M	M4L	161	51

ΔL_1 = incremento de la longitud respecto a la cota LB del motor estándar correspondiente.

ΔL_2 = incremento de la longitud respecto a la cota LB del motor freno correspondiente. Solo para motores BN.

U1

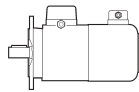

Terminales de alimentación del ventilador en caja de bornes independiente.

Los motores freno de tamaños BN 71...BN 160MR, M1...M4L, con variante **U1**, la palanca de desbloqueo no permite su montaje en la posición AA.

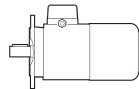

La opción es incompatible con motores según las normas CSA y UL (opción CUS).

U2



Los terminales de alimentación del ventilador están situados en la caja de bornes principal del motor. Esta opción no es aplicable para los motores BN 160M ... BN 200L, M5, con excepción del motor 160 MR, por lo cual la opción está disponible a los motores con opción CUS (conformes a las normas CSA y UL)

(F 59)

		V a.c. $\pm 10\%$	Hz	P [W]	I [A]
BN 71	M1	1 ~ 230	50 / 60	22	0.12
BN 80	M2			22	0.12
BN 90	—			40	0.30
BN 100	M3	3 ~ 230 Δ / 400Y		40	0.26 / 0.09
BN 112	—			50	0.26 / 0.15
BN 132 ... BN 160MR	M4L			110	0.38 / 0.22

M9.13 Sombrerete protector de la lluvia

RC

El dispositivo protector de la lluvia está recomendado cuando el motor se instale verticalmente con el eje hacia abajo; sirve para proteger al propio motor de la entrada de cuerpos sólidos y del goteo. Las dimensiones adicionales están indicadas en la tabla siguiente.

El sombrerete excluye las variantes PS, EN1, EN2, EN3, EN4, EN5, EN6.

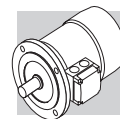

(F 60)

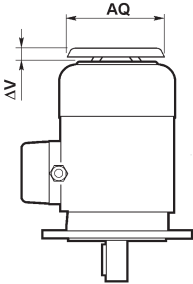
	AQ	ΔV	
BN 63	118	24	
BN 71	134	27	
BN 80	152	25	
BN 90	168	30	
BN 100	190	28	
BN 112	211	32	
BN 132...BN 160MR	254	32	
BN 160M...BN 180M	302	36	
BN 180L...BN 200L	340	36	

M9.14 Sombrero para ambiente textil

TC

La variante del sombrero tipo TC se ha de especificar cuando el motor se instale en ambientes de la industria textil, donde existen filamentos que podrían obstruir la rejilla de la tapa del ventilador, impidiendo el flujo regular del aire de refrigeración.

Esta opción excluye las variantes EN1, EN2, EN3, EN4, EN5, EN6. Las dimensiones totales son las mismas que las del sombrero tipo RC.

M9.15 Dispositivos de retroacción

Los motores pueden dotarse con seis tipos distintos de encoder que se describen a continuación. El montaje del encoder excluye la ejecución con doble eje (PS) y del sombrero de protección (RC, TC).

EN1

Encoder incremental, $V_{IN} = 5 V$, salida "line-driver" RS 422.

EN2

Encoder incremental, $V_{IN} = 10-30 V$, salida "line-driver" RS 422

EN3

Encoder incremental, $V_{IN} = 12-30 V$, salida "push-pull" 12-30 V

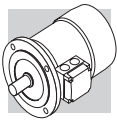

EN4

Encoder sin/cos, $V_{IN} = 4.5-5.5$ V, salida Sinus $0.5V_{PP}$.

EN5

Encoder absoluto monogiro, interfaz HIPERFACE®, $V_{IN} = 7-12$ V.

EN6

Encoder absoluto multigiro, interfaz HIPERFACE®, $V_{IN} = 7-12$ V.

(F 61)

	EN1	EN2	EN3	EN4	EN5	EN6
Interfaz	TTL/RS 422	TTL/RS 422	HTL/push-pull	Sinus 0.5 VPP	HIPERFACE®	HIPERFACE®
Tensión alimentación [V]	4...6	10...30	12...30	4.4...5.5	7...12	7...12
Tensión de salida [V]	5	5	12...30	—	—	—
Intensidad de utilización sin carga [mA]	120	100	100	40	80	80
Nº de impulsos por revolución	1024					
Resolución	—	—	—	—	15 bit	15 bit
Revoluciones	—	—	—	—	—	12 bit
Nº de señales	6 (A, B, Z + señales invertidas)			6 (cos-, cos+, sin-, sin+, Z, \bar{Z})	—	—
Frecuencia máx. de salida [kHz]	600			200		
Velocidad máxima [min^{-1}]	6000 (9000 min^{-1} para 10 s)					
Rango de temperatura [°C]	-30 ... +100					
Grado de protección	IP 65					

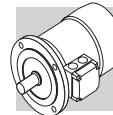

(F 62)

EN1, EN2, EN3, EN4, EN5, EN6	
BN 63...BN 200L	M05...M5
BN 63_FD...BN 200L_FD	M05_FD...M5_FD
BN 63_FA...BN 200L_FA	M05_FA...M5_FA

(F 63)

EN_ + U1		
BN 160M...BN 180M	M5	L3 72
BN 180L...BN 200L	-	82
BN 160M_FD...BN 180M_FD	M5_FD	35
BN 180L_FD...BN 200L_FD	-	41

Si la opción EN_ se solicita para motores de tamaño BN71...BN160MR / M1...M4 junto a la opción U1/U2, la variación de las dimensiones del motor coincide con las de la opción U1/U2.



M9.16 Protección de la superficie

C

Cuando no se requiere ninguna clase de protección específica, las superficies de los motores están protegidas al menos con la clase de corrosividad C2 (UNI EN ISO 12944-2). Para mejorar la resistencia a la corrosión atmosférica, los motores se pueden entregar con una protección de superficie C3 y C4.

PROTECCIÓN SUPERFICIE	Ambientes típicos	Temperatura máxima superficie	Clase corrosividad conforme a UNI EN ISO 12944-2
C3	Ambientes industriales y urbanos con una humedad relativa de hasta el 100% (contaminación atmosférica media)	120°C	C3
C4	Zonas industriales, zonas costeras, fábrica de productos químicos, con una humedad relativa de hasta el 100% (alta contaminación atmosférica)	120°C	C4

Los motores con la protección opcional de clase C3 o C4 están disponibles en una variedad de colores. Si no se solicita color específico (ver la opción "PINTURA") el acabado de los motores será en RAL 7042.

Los motores también se pueden suministrar con protección de la superficie para la clase de corrosividad C5 según la norma UNI EN ISO 12944-2. Póngase en contacto con nuestro Servicio Técnico para más detalles.

M9.17 Pintura

RAL

Los motores con la protección opcional de clase C3 o C4 están disponibles en los colores que figuran en la siguiente tabla.

PINTURA	Color	Número RAL
RAL7042*	Gris Tráfico A	7042
RAL5010	Azul genciana	5010
RAL9005	Negro Jet	9005
RAL9006	Aluminio Blanco	9006
RAL9010	Blanco Puro	9010
RAL7035	Gris claro	7035
RAL7001	Gris-plata	7001
RAL5015	Azul cielo	5015
RAL7037	Gris polvoriento	7037
RAL5024	Azul pastel	5024

NOTA - Las opciones "PINTURA" sólo se pueden especificar en combinación con las opciones "PROTECCIÓN DE LA SUPERFICIE".



M9.18 Documentación

ACM

Certificado de conformidad de los motores

Documento en el cual se certifica la conformidad del producto con lo indicado en el pedido y su fabricación según los procedimientos estándar de producción y control que establece el sistema de calidad de Bonfiglioli Riduttori.



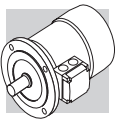

CC

Certificado de prueba

La obtención de este certificado conlleva verificar la conformidad del producto con el pedido, realizar inspecciones visuales de carácter general y las pruebas instrumentales de las características eléctrica (funcionamiento en vacío). Para llevar a cabo la prueba se utiliza una muestra estadística del lote de expedición.





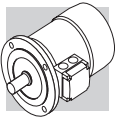

M10 DATOS TÉCNICOS DE LOS MOTORES

2P		3000 min ⁻¹ - S1										50 Hz														
P _n kW		n min ⁻¹	M _n Nm	IE1	η (100%) %	η (75%) %	η (50%) %	cosφ	In 400V A	Is In	Ms Mn	Ma Mn	J _m x 10 ⁻⁴ kgm ²	IM B5  Kg	freno c.c.					freno c.a.						
															Mod	Mb Nm	Z _o 1/h	NB	SB	J _m x 10 ⁻⁴ kgm ²	IM B5  Kg	Mod	Mb Nm	Z _o 1/h	J _m x 10 ⁻⁴ kgm ²	IM B5  Kg
0.18	BN 63A	2	2730	0.63	○	59.9	56.9	51.9	0.77	0.66	3.0	2.1	2.0	2.0	3.5	FD 02	1.75	3900	4800	2.6	5.2	FA 02	1.75	4800	2.6	5.0
0.25	BN 63B	2	2740	0.87	○	66.0	64.8	64.8	0.76	0.72	3.3	2.3	2.3	2.3	3.9	FD 02	1.75	3900	4800	3.0	5.6	FA 02	1.75	4800	3.0	5.4
0.37	BN 63C	2	2800	1.26	○	69.1	66.8	66.8	0.78	0.99	3.9	2.6	2.6	3.3	5.1	FD 02	3.5	3600	4500	3.9	6.8	FA 02	3.5	4500	3.9	6.6
0.37	BN 71A	2	2820	1.25	○	73.8	73.0	70.6	0.76	0.95	4.8	2.8	2.6	3.5	5.4	FD 03	3.5	3000	4100	4.6	8.1	FA 03	3.5	4200	4.6	7.8
0.55	BN 71B	2	2820	1.86	○	76.0	75.8	74.8	0.76	1.37	5.0	2.9	2.8	4.1	6.2	FD 03	5	2900	4200	5.3	8.9	FA 03	5	4200	5.3	8.6
0.75	BN 71C	2	2810	2.6	○	76.6	76.2	76.2	0.76	1.86	5.1	3.1	2.8	5.0	7.3	FD 03	5	1900	3300	6.1	10.0	FA 03	5	3600	6.1	9.7
0.75	BN 80A	2	2810	2.6	●	76.2	75.5	68.3	0.81	1.75	4.8	2.6	2.2	7.8	8.6	FD 04	5	1700	3200	9.4	12.5	FA 04	5	3200	9.4	12.4
1.1	BN 80B	2	2800	3.8	●	76.4	76.2	75.0	0.81	2.57	4.8	2.8	2.4	9.0	9.5	FD 04	10	1500	3000	10.6	13.4	FA 04	10	3000	10.6	13.3
1.5	BN 80C	2	2800	5.1	●	79.1	79.5	77.2	0.81	3.4	4.9	2.7	2.4	11.4	11.3	FD 04	15	1300	2600	13.0	15.2	FA 04	15	2600	13.0	15.1
1.5	BN 90SA	2	2870	5.0	●	82.0	81.5	78.1	0.80	3.4	5.9	2.7	2.6	12.5	12.3	FD 14	15	900	2200	14.1	16.5	FA 14	15	2200	14.1	16.4
1.85	BN 90SB	2	2880	6.1	●	82.5	82.0	75.4	0.80	4.0	6.2	2.9	2.6	16.7	14	FD 14	15	900	2200	18.3	18.2	FA 14	15	2200	18.3	18.1
2.2	BN 90L	2	2880	7.3	●	82.7	82.1	80.8	0.80	4.8	6.3	2.9	2.7	16.7	14	FD 05	26	900	2200	21	20	FA 05	26	2200	21	20.7
3	BN 100L	2	2860	10.0	●	81.5	81.3	77.4	0.79	6.7	5.6	2.6	2.2	31	20	FD 15	26	700	1600	35	26	FA 15	26	1600	35	27
4	BN 100LB	2	2870	13.3	●	83.1	83.0	77.8	0.80	8.7	5.8	2.7	2.5	39	23	FD 15	40	450	900	43	29	FA 15	40	1000	43	30
4	BN 112M	2	2900	13.2	●	85.5	84.5	83.0	0.82	8.2	6.9	3.0	2.9	57	28	FD 06S	40	—	950	66	39	FA 06S	40	950	66	40
5.5	BN 132SA	2	2890	18.2	●	84.7	84.5	81.2	0.84	11.2	5.9	2.6	2.2	101	35	FD 06	50	—	600	112	48	FA 06	50	600	112	49
7.5	BN 132SB	2	2900	25	●	86.5	86.3	84.4	0.85	14.7	6.4	2.6	2.2	145	42	FD 06	50	—	550	154	55	FA 06	50	550	154	56
9.2	BN 132M	2	2930	30	●	87.0	86.5	83.6	0.86	17.7	6.7	2.8	2.3	178	53	FD 56	75	—	430	189	66	FA 06	75	430	189	67
11	BN 160MR	2	2920	36	●	87.6	87.0	86.0	0.88	20.6	6.9	2.9	2.5	210	65											
15	BN 160MB	2	2930	49	●	89.6	89.4	88.0	0.86	28.1	7.1	2.6	2.3	340	84											
18.5	BN 160L	2	2930	60	●	90.4	90.1	89.0	0.86	34	7.6	2.7	2.3	420	97											
22	BN 180M	2	2930	72	●	89.9	89.7	89.5	0.88	40	7.8	2.6	2.4	490	109											
30	BN 200LA	2	2930	98	●	90.7	90.1	87.6	0.89	54	7.8	2.7	2.9	770	140											

○ = n.a. ● = IE1



6P		1000 min ⁻¹ - S1												50 Hz												
P _n kW		n min ⁻¹	M _n Nm	IE1	η (100%) %	η (75%) %	η (50%) %	cosφ	In 400V A	Is In %	Ms Mn %	Ma Mn %	J _m x 10 ⁻⁴ kgm ²	IM B5  Kg	freno c.c.											
															FD						FA					
															Mod	Mb Nm	Z ₀ 1/h	NB	SB	J _m x 10 ⁻⁴ kgm ²	IM B5  Kg	Mod	Mb Nm	Z ₀ 1/h	J _m x 10 ⁻⁴ kgm ²	IM B5  Kg
0.09	BN 63A	6	0.98	○	41.0	41.0	32.9	0.53	0.60	2.1	2.1	1.8	3.4	4.6	FD 02	3.5	9000	14000	14000	4.0	6.3	FA 02	3.5	14000	4.0	6.1
0.12	BN 63B	6	1.32	○	45.0	44.0	41.8	0.60	0.64	2.1	1.9	1.7	3.7	4.9	FD 02	3.5	9000	14000	14000	4.3	6.6	FA 02	3.5	14000	4.3	6.4
0.18	BN 71A	6	1.91	○	55.0	55.5	51.0	0.69	0.68	2.6	1.9	1.7	8.4	5.5	FD 03	5	8100	13500	13500	9.5	8.2	FA 03	5.0	13500	9.5	7.9
0.25	BN 71B	6	2.70	○	62.0	58.5	51.4	0.71	0.82	2.6	1.9	1.7	10.9	6.7	FD 03	5	7800	13000	13000	12	9.4	FA 03	5.0	13000	12	9.1
0.37	BN 71C	6	3.9	○	66.0	60.0	53.3	0.69	1.17	3.0	2.4	2.0	12.9	7.7	FD 53	7.5	5100	9500	9500	14	10.4	FA 03	7.5	9500	14	10.1
0.37	BN 80A	6	3.9	○	68.0	67.4	63.3	0.68	1.15	3.2	2.2	2.0	21	9.9	FD 04	10	5200	8500	8500	23	13.8	FA 04	10	8500	23	13.7
0.55	BN 80B	6	5.7	○	70.0	69.8	64.3	0.68	1.67	3.9	2.6	2.2	25	11.3	FD 04	15	4800	7200	7200	27	15.2	FA 04	15	7200	27	15.1
0.75	BN 80C	6	7.8	●	70.0	70.0	64.4	0.65	2.38	3.8	2.5	2.2	28	12.2	FD 04	15	3400	6400	6400	30	16.1	FA 04	15	6400	30	16.0
0.75	BN 90S	6	7.8	●	70.0	69.0	64.2	0.68	2.27	3.8	2.4	2.2	26	12.6	FD 14	15	3400	6500	6500	28	16.8	FA 14	15	6500	28	16.7
1.1	BN 90L	6	11.4	●	72.9	72.6	69.1	0.69	3.2	3.9	2.3	2.0	33	15	FD 05	26	2700	5000	5000	37	21	FA 05	26	5000	37	22
1.5	BN 100LA	6	15.2	●	75.2	74.2	70.3	0.72	4.0	4.1	2.1	2.0	82	22	FD 15	40	1900	4100	4100	86	28	FA 15	40	4100	86	29
1.85	BN 100LB	6	19.0	●	76.6	72.8	62.6	0.73	4.8	4.6	2.1	2.0	95	24	FD 15	40	1700	3600	3600	99	30	FA 15	40	3600	99	31
2.2	BN 112M	6	22	●	78.5	79.0	76.5	0.73	5.5	4.8	2.2	2.0	168	32	FD 06S	60	—	2100	2100	177	42	FA 06S	60	2100	177	44
3	BN 132S	6	30	●	79.7	77.0	75.1	0.76	7.1	5.1	1.9	1.8	216	36	FD 56	75	—	1400	1400	226	49	FA 06	75	1400	226	50
4	BN 132MA	6	40	●	81.4	81.5	79.5	0.77	9.2	5.5	2.0	1.8	295	45	FD 06	100	—	1200	1200	305	58	FA 07	100	1200	318	63
5.5	BN 132MB	6	56	●	83.1	80.9	79.1	0.78	12.2	6.1	2.1	1.9	383	56	FD 07	150	—	1050	1050	406	72	FA 07	150	1050	406	74
7.5	BN 160M	6	75	●	85.0	85.0	84.8	0.81	15.7	5.9	2.2	2.0	740	83	FD 08	170	—	900	900	815	112	FA 08	170	900	815	113
11	BN 160L	6	109	●	86.4	86.5	85.9	0.81	22.7	6.6	2.5	2.3	970	103	FD 08	200	—	800	800	1045	133	FA 08	200	800	1045	133
15	BN 180L	6	148	●	87.7	88.0	87.3	0.82	30	6.2	2.0	2.4	1550	130	FD 09	300	—	600	600	1750	170	FA 08	200	800	1045	133
18.5	BN 200LA	6	184	●	88.6	88.0	87.3	0.81	37	5.9	2.0	2.3	1700	145	FD 09	400	—	450	450	1900	185	FA 08	200	800	1045	133

○ = n.a. ● = IE1





2/4P **3000/1500 min⁻¹ - S1** **50 Hz**

P _n kW		freno c.c.														freno c.a.							
		FD														FA							
		IM B5 Kg	J _m x 10 ⁻⁴ kgm ²	M _a M _n	M _s M _n	I _s I _n	cos φ	η	M _n Nm	n min ⁻¹	In 400V A	I _s I _n	M _s M _n	M _a M _n	J _m x 10 ⁻⁴ kgm ²	IM B5 Kg	Mod	Mb Nm	Z ₀ 1/h	Mb Nm	Z ₀ 1/h	J _m x 10 ⁻⁴ kgm ²	IM B5 Kg
0.20	BN 63B	2	2700	0.71	55	0.82	0.64	3.5	2.1	1.9	2.9	4.4	FD 02	3.5	2200	2600	5100	FA 02	3.5	2600	5100	3.5	5.9
0.15		4	1350	1.06	49	0.67	0.66	2.6	1.8	1.7													
0.28	BN 71A	2	2700	0.99	56	0.82	0.88	2.9	1.9	1.7	4.7	4.4	FD 03	3.5	2100	2400	4800	FA 03	3.5	2400	4800	5.8	6.8
0.20		4	1370	1.39	59	0.72	0.68	3.1	1.8	1.7													
0.37	BN 71B	2	2740	1.29	56	0.82	1.16	3.5	1.8	1.8	5.8	5.1	FD 03	5.0	1400	2100	4200	FA 03	5.0	2100	4200	6.9	7.5
0.25		4	1390	1.72	60	0.73	0.82	3.3	2.0	1.9													
0.45	BN 71C	2	2780	1.55	63	0.85	1.21	3.8	1.8	1.8	6.9	5.9	FD 03	5.0	1400	2100	4200	FA 03	5.0	2100	4200	8.0	8.3
0.30		4	1400	2.0	63	0.73	0.94	3.6	2.0	1.9													
0.55	BN 80A	2	2800	1.9	63	0.85	1.48	3.9	1.7	1.7	15	8.2	FD 04	5.0	1600	2300	4000	FA 04	5.0	2300	4000	17	12.0
0.37		4	1400	2.5	67	0.79	1.01	4.1	1.8	1.9													
0.75	BN 80B	2	2780	2.6	65	0.85	1.96	3.8	1.9	1.8	20	9.9	FD 04	10	1400	1600	3600	FA 04	10	1600	3600	22	13.7
0.55		4	1400	3.8	68	0.81	1.44	3.9	1.7	1.7													
1.1	BN 90S	2	2790	3.8	71	0.82	2.73	4.7	2.3	2.0	21	12.2	FD 14	10	1500	1600	2800	FA 14	10	1600	2800	23	16.3
0.75		4	1390	5.2	66	0.79	2.08	4.6	2.4	2.2													
1.5	BN 90L	2	2780	5.2	70	0.85	3.64	4.5	2.4	2.1	28	14.0	FD 05	26	1050	1200	2000	FA 05	26	1200	2000	32	21
1.1		4	1390	7.6	73	0.81	2.69	4.7	2.5	2.2													
2.2	BN 100LA	2	2800	7.5	72	0.85	5.2	4.5	2.0	1.9	40	18.3	FD 15	26	600	900	2300	FA 15	26	900	2300	44	25
1.5		4	1410	10.2	73	0.79	3.8	4.7	2.0	2.0													
3.5	BN 100LB	2	2850	11.7	80	0.84	7.5	5.4	2.2	2.1	61	25	FD 15	40	500	900	2100	FA 15	40	900	2100	65	32
2.5		4	1420	16.8	82	0.80	5.5	5.2	2.2	2.2													
4	BN 112M	2	2880	13.3	79	0.83	8.8	6.1	2.4	2.0	98	30	FD 06S	60	—	700	1200	FA 06S	60	700	1200	107	42
3.3		4	1420	22.2	80	0.80	7.4	5.1	2.1	2.0													
5.5	BN 132S	2	2890	18.2	80	0.87	11.4	5.9	2.4	2.0	213	44	FD 06	75	—	350	900	FA 06	75	350	900	223	58
4.4		4	1440	29	82	0.84	9.2	5.3	2.2	2.0													
7.5	BN 132MA	2	2900	25	82	0.87	15.2	6.5	2.4	2.0	270	53	FD 06	100	—	350	900	FA 07	100	350	900	280	71
6		4	1430	40	84	0.85	12.1	5.8	2.3	2.1													
9.2	BN 132MB	2	2920	30	83	0.86	18.6	6.0	2.6	2.2	319	59	FD 07	150	—	300	800	FA 07	150	300	800	342	77
7.3		4	1440	48	85	0.85	14.6	5.5	2.3	2.1													



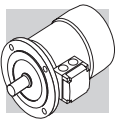

2/6P **3000/1000 min-1 - S3 60/40%** **50 Hz**

P _n kW			n min ⁻¹	M _n Nm	η	cosφ	I _n 400V A	I _s I _n	M _s M _n	M _a M _n	J _m x 10 ⁻⁴ kgm ²	IM B5 	freno c.c.				freno c.a.							
													FD				FA							
													Mod	Mb Nm	Z ₀ 1/h	NB	SB	Mod	Mb Nm	Z ₀ 1/h	IM B5 	J _m x 10 ⁻⁴ kgm ²	Mod	Mb Nm
0.25	0.08	2	2850	0.84	60	0.82	0.73	4.3	1.9	1.8	6.9	5.9	FD 03	1.75	1500	1700	8.0	8.6	FA 03	2.5	1700	13000	8.0	8.3
		6	910	0.84	43	0.70	0.38	2.1	1.4	1.5					10000	13000								
0.37	0.12	2	2880	1.23	62	0.80	1.08	4.4	1.9	1.8	9.1	7.3	FD 03	3.5	1000	1300	10.2	10.0	FA 03	3.5	1300	11000	10.2	9.7
		6	900	1.27	44	0.73	0.54	2.4	1.4	1.5					9000	11000								
0.55	0.18	2	2800	1.88	63	0.86	1.47	4.5	1.9	1.7	20	9.9	FD 04	5.0	1500	1800	22	13.8	FA 04	5.0	1800	6300	22	13.7
		6	930	1.85	52	0.65	0.77	3.3	2.0	1.9					4100	6300								
0.75	0.25	2	2800	2.6	66	0.87	1.89	4.3	1.8	1.6	25	11.3	FD 04	5.0	1700	1900	27	15.2	FA 04	5.0	1900	6000	27	15.1
		6	930	2.6	54	0.67	1.00	3.2	1.7	1.8					3800	6000								
1.10	0.37	2	2860	3.7	67	0.84	2.82	4.7	2.1	1.9	28	14.0	FD 05	13	1400	1600	32	20	FA 05	13	1600	5200	32	21
		6	920	3.8	59	0.71	1.27	3.3	1.6	1.6					3400	5200								
1.5	0.55	2	2880	5	73	0.84	3.53	5.1	1.9	2.0	40	18.3	FD 15	13	1000	1200	44	24	FA 15	13	1200	4000	44	25
		6	940	5.6	64	0.67	1.85	3.5	1.7	1.8					2900	4000								
2.2	0.75	2	2900	7.2	77	0.85	4.9	5.9	2.0	2.0	61	25	FD 15	26	700	900	65	31	FA 15	26	900	3000	65	32
		6	950	7.5	67	0.64	2.5	3.3	1.9	1.8					2100	3000								
3	1.1	2	2900	9.9	78	0.87	6.4	6.3	2.0	2.1	98	30	FD 06S	40	—	1000	107	40	FA 06S	40	1000	2600	107	32
		6	950	11.1	72	0.64	3.4	3.9	1.8	1.8					—	2600								
4.5	1.5	2	2910	14.8	78	0.84	9.9	5.8	1.9	1.8	213	44	FD 66	37	—	500	223	57	FA 06	37	500	2100	223	58
		6	960	14.9	74	0.67	4.4	4.2	1.9	2.0					—	2100								
5.5	2.2	2	2920	18.0	78	0.87	11.7	6.2	2.1	1.9	270	53	FD 66	50	—	400	280	66	FA 06	50	400	1900	280	67
		6	960	22	77	0.71	5.8	4.3	2.1	2.0					—	1900								



2/8P **3000/750 min-1 - S3 60/40%** **50 Hz**





P _n kW			n min ⁻¹	M _n Nm	η	cos φ	I _n 400V A	I _s I _n	M _s M _n	M _a M _n	J _m x 10 ⁻⁴ kgm ²	IM B5 	freno c.c.						freno c.a.									
													FD			FA			FD			FA						
													Mod	Mb	Z _o 1/h	Mod	Mb	Z _o 1/h	Mod	Mb	Z _o 1/h	Mod	Mb	Z _o 1/h	Mod	Mb	Z _o 1/h	Mod
0.25	0.06	BN 71A	2	2790	0.86	61	0.87	3.9	1.8	1.9	10.9	6.7	FD 03	1.75	1300	1400	FA 03	2.5	1400	13000	12	9.4	1400	13000	12	9.1	1400	13000
0.37	0.09	BN 71B	2	2800	1.26	63	0.86	3.9	1.8	1.9	12.9	7.7	FD 03	3.5	1200	1300	FA 03	3.5	1300	13000	14	10.4	1300	13000	14	10.1	1300	13000
0.55	0.13	BN 80A	2	2830	1.86	66	0.86	4.4	2.1	2.0	20	9.9	FD 04	5.0	1500	1800	FA 04	5.0	1800	8000	22	13.8	1800	8000	22	13.7	1800	8000
0.75	0.18	BN 80B	2	2800	2.6	68	0.88	4.6	2.1	2.0	25	11.3	FD 04	10	1700	1900	FA 04	10	1900	7300	27	15.2	1900	7300	27	15.1	1900	7300
1.10	0.28	BN 90L	2	2830	3.7	63	0.84	4.5	2.1	1.9	28	14.0	FD 05	13	1400	1600	FA 05	13	1600	5100	32	20	1600	5100	32	21	1600	5100
1.5	0.37	BN 100LA	2	2880	5.0	69	0.85	4.7	1.9	1.8	40	18.3	FD 15	13	1000	1200	FA 15	13	1200	5000	44	25	1200	5000	44	25	1200	5000
2.4	0.55	BN 100LB	2	2900	7.9	75	0.82	5.4	2.1	2.0	61	25	FD 15	26	550	700	FA 15	26	700	3500	65	31	700	3500	65	32	700	3500
3	0.75	BN 112M	2	2900	9.9	76	0.87	6.3	2.1	1.9	98	30	FD 06S	40	—	900	FA 06S	40	900	—	107	40	900	—	107	42	900	—
4	1	BN 132S	2	2870	13.3	73	0.84	5.6	2.3	2.4	213	44	FD 66	37	—	500	FA 06	37	500	3500	223	57	500	3500	223	58	500	3500
5.5	1.5	BN 132M	2	2870	18.3	75	0.84	6.1	2.4	2.5	270	53	FD 06	50	—	400	FA 06	50	400	2400	280	66	400	2400	280	67	400	2400





4/6P		1500/1000 min ⁻¹ - S1													50 Hz							
		freno c.c.													freno c.a.							
		FD						FA														
P _n		n	M _n	η	cos φ	I _n	I _s	M _s	M _a	J _m	IM B5	Mod	Mb	Z ₀	J _m	IM B5	Mod	Mb	Z ₀	J _m	IM B5	
kW		min ⁻¹	Nm	%		A	$\frac{I_s}{I_n}$	$\frac{M_s}{M_n}$	$\frac{M_a}{M_n}$	$\times 10^{-4}$ kgm ²	$\frac{kg}{kg}$		Nm	1/h	$\times 10^{-4}$ kgm ²	$\frac{kg}{kg}$		Nm	1/h	$\times 10^{-4}$ kgm ²	$\frac{kg}{kg}$	
0.22	BN 71B	4	1.5	64	0.74	0.67	3.9	1.8	1.9	9.1	7.3	FD 03	3.5	2500	10.2	10.0	FA 03	3.5	3500	10.2	10.2	9.7
0.13		6	1.4	43	0.67	0.65	2.3	1.6	1.7					5000	9000				9000			
0.30	BN 80A	4	2.0	61	0.82	0.87	3.5	1.3	1.5	15	8.2	FD 04	5.0	2500	16.6	12.1	FA 04	5.0	3100	16.6	16.6	12.0
0.20		6	2.1	54	0.66	0.81	3.2	1.9	2.0					4000	6000				6000			
0.40	BN 80B	4	2.7	63	0.75	1.22	3.9	1.8	1.8	20	9.9	FD 04	10	1800	22	13.8	FA 04	10	2300	22	22	13.7
0.26		6	2.7	55	0.70	0.97	2.7	1.5	1.6					3600	5500				5500			
0.55	BN 90S	4	3.7	70	0.78	1.45	4.5	2.0	1.9	21	12.2	FD 14	10	1500	23	16.1	FA 14	10	2100	23	23	16.3
0.33		6	3.4	62	0.70	1.10	3.7	2.3	2.0					2500	4100				4100			
0.75	BN 90L	4	5.0	74	0.78	1.88	4.3	1.9	1.8	28	14	FD 05	13	1400	32	20	FA 05	13	2000	32	32	21
0.45		6	4.7	66	0.71	1.39	3.3	2.0	1.9					2300	3600				3600			
1.1	BN 100LA	4	7.2	74	0.79	2.72	5.0	1.7	1.9	82	22	FD 15	26	1400	86	28	FA 15	26	2000	86	86	29
0.8		6	8.0	65	0.69	2.57	4.1	1.9	2.1					2100	3300				3300			
1.5	BN 100LB	4	9.9	75	0.79	3.65	5.1	1.7	1.9	95	25	FD 15	26	1300	99	31	FA 15	26	1800	99	99	32
1.1		6	11.1	72	0.68	3.24	4.3	2.0	2.1					2000	3000				3000			
2.3	BN 112M	4	15.2	75	0.78	5.7	5.2	1.8	1.9	168	32	FD 06S	40	—	177	42	FA 06S	40	1600	177	177	44
1.5		6	14.9	73	0.72	4.1	4.9	2.0	2.0					—	2400				2400			
3.1	BN 132S	4	20	83	0.83	6.5	5.9	2.1	2.0	213	44	FD 06	37	—	223	57	FA 06	37	1200	223	223	58
2		6	20	77	0.75	4.9	4.5	2.1	2.1					—	1900				1900			
4.2	BN 132MA	4	27	84	0.82	8.8	5.9	2.1	2.2	270	53	FD 06	50	—	280	66	FA 06	50	900	280	280	67
2.6		6	26	79	0.72	6.6	4.3	2.0	2.0					—	1500				1500			

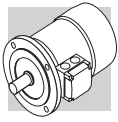

4/8P **1500/750 min⁻¹ - S1** **50 Hz**

P _n kW			n min ⁻¹	M _n Nm	η %	cos φ	I _n 400V A	I _s I _n	M _s M _n	M _a M _n	J _m x 10 ⁻⁴ kgm ²	IM B5 	freno c.c.						freno c.a.					
													FD						FA					
													Mod	Mb Nm	Z _o 1/h	NB	SB	J _m x 10 ⁻⁴ kgm ²	IM B5 	Mod	Mb Nm	Z _o 1/h	J _m x 10 ⁻⁴ kgm ²	IM B5 
0.37	0.18	4	1400	2.5	63	0.82	1.03	3.3	1.4	1.4	15	8.2	FD 04	10	2300	3500	16.6	12.1	FA 04	10	3500	16.6	12.0	
		8	690	2.5	44	0.60	0.98	2.2	1.5	1.6					4500	7000					7000			
0.55	0.30	4	1390	3.8	65	0.86	1.42	3.8	1.7	1.6	20	9.9	FD 04	10	2200	2900	22	13.8	FA 04	10	2900	22	13.7	
		8	670	4.3	49	0.65	1.36	2.3	1.7	1.8					4200	6500					6500			
0.65	0.35	4	1390	4.5	73	0.85	1.51	4.0	1.9	1.9	28	13.6	FD 14	15	2300	2800	30	17.8	FA 14	15	2800	30	17.7	
		8	690	4.8	49	0.57	1.81	2.5	2.1	2.2					3500	6000					6000			
0.9	0.5	4	1370	6.3	73	0.87	2.05	3.8	1.8	1.8	30	15.1	FD 05	26	1700	2100	34	21	FA 05	26	2100	34	22	
		8	670	7.1	57	0.62	2.04	2.4	2.1	2.0					2500	4200					4200			
1.30	0.70	4	1420	8.7	72	0.83	3.14	4.3	1.7	1.8	82	22	FD 15	40	1300	1700	86	28	FA 15	40	1700	86	29	
		8	700	9.6	58	0.64	2.72	2.8	1.8	1.8					2000	3400					3400			
1.8	0.9	4	1420	12.1	69	0.87	4.3	4.2	1.6	1.7	95	25	FD 15	40	1200	1700	99	31	FA 15	40	1700	99	32	
		8	700	12.3	62	0.63	3.3	3.2	1.7	1.8					1600	2600					2600			
2.2	1.2	4	1440	14.6	77	0.85	4.9	5.3	1.8	1.8	168	32	FD 06S	60	—	1200	177	42	FA 06S	60	1200	177	43	
		8	710	16.1	70	0.63	3.9	3.3	1.9	1.8					—	2000					2000			
3.6	1.8	4	1440	24	80	0.82	7.9	6.5	2.1	1.9	295	45	FD 56	75	—	1000	305	58	FA 06	75	1000	305	59	
		8	720	24	72	0.55	6.6	4.6	1.9	2.0					—	1400					1400			
4.6	2.3	4	1450	30	81	0.83	9.9	6.5	2.2	1.9	383	56	FD 06	100	—	1000	393	69	FA 07	100	1000	393	74	
		8	720	31	73	0.54	8.4	4.4	2.3	2.0					—	1300					1300			







2P		3000 min ⁻¹ - S1																50 Hz							
		freno c.c.																freno c.a.							
		FD																FA							
P _n		n	M _n	IE1	η (100%)	η (75%)	η (50%)	cosφ	In	In	Is	Ms	Mia	J _m	IM B5	Mod	Mb	Z _c	J _m	IM B5	Mod	Mb	Z _c	J _m	IM B5
kW		min ⁻¹	Nm		%	%	%		A	A				kgm ²	kg		Nm	1/h	kgm ²	kg		Nm	1/h	kgm ²	kg
0.18	M 05A	2	2730	0.63	○	59.9	56.9	51.9	0.77	0.56	3.0	2.1	2.0	2.0	3.2	FD 02	1.75	3900	2.6	4.9	FA 02	1.75	4800	2.6	4.7
0.25	M 05B	2	2740	0.87	○	66.0	64.8	64.8	0.76	0.72	3.3	2.3	2.3	2.3	3.6	FD 02	1.75	3900	3.0	5.3	FA 02	1.75	4800	3.0	5.1
0.37	M 05C	2	2800	1.26	○	69.1	66.8	66.8	0.78	0.99	3.9	2.6	2.6	3.3	4.8	FD 02	3.5	3600	3.9	6.5	FA 02	3.5	4500	3.9	6.3
0.55	M 15D	2	2820	1.86	○	76.0	75.8	74.8	0.76	1.37	5.0	2.9	2.8	4.1	5.8	FD 03	5	2900	5.3	8.5	FA 03	5	4200	5.3	8.2
0.75	M 15A	2	2810	2.6	○	76.6	76.2	76.2	0.76	1.86	5.1	3.1	2.8	5.0	6.9	FD 03	5	1900	6.1	9.6	FA 03	5	3300	6.1	9.3
1.1	M 25A	2	2800	3.8	●	76.4	76.2	75.0	0.81	2.57	4.8	2.8	2.4	9.0	8.8	FD 04	10	1500	10.6	11.9	FA 04	10	3000	10.6	12.6
1.5	M 25B	2	2800	5.1	●	79.1	79.5	77.2	0.81	3.4	4.9	2.7	2.4	11.4	10.6	FD 04	15	1300	13.0	9.9	FA 04	15	2600	13.0	14.4
2.2	M 35A	2	2880	7.3	●	82.7	82.1	81.0	0.80	4.8	6.3	2.9	2.7	24	15.5	FD 15	26	1100	28	22	FA 15	26	2400	28	23
3	M 35LA	2	2860	10.0	●	81.5	81.3	77.4	0.79	6.7	5.6	2.6	2.2	31	18.7	FD 15	26	700	35	25	FA 15	26	1600	35	26
4	M 35LB	2	2870	13.3	●	83.1	83.0	77.8	0.80	8.7	5.8	2.7	2.5	39	22	FD 15	40	450	43	28	FA 15	40	900	43	29
5.5	M 45A	2	2890	18.2	●	84.7	84.5	81.2	0.84	11.2	5.9	2.6	2.2	101	33	FD 06	50	—	112	46	FA 06	50	600	112	47
7.5	M 45B	2	2900	25	●	86.5	86.3	84.4	0.85	14.7	6.4	2.6	2.2	145	40	FD 06	50	—	154	53	FA 06	50	550	154	54
9.2	M 45LA	2	2930	30	●	87.0	86.5	83.6	0.86	17.7	6.7	2.8	2.3	178	51	FD 06	75	—	189	64	FA 06	75	430	189	65
11	M 45LC	2	2920	36	●	87.6	87.0	86.0	0.88	20.6	6.9	2.9	2.5	210	60	FD 06	75	—	189	64	FA 06	75	430	189	65
15	M 55B	2	2930	49	●	89.6	89.4	88.0	0.86	28.1	7.1	2.6	2.3	340	70	FD 06	75	—	189	64	FA 06	75	430	189	65
18.5	M 55C	2	2930	60	●	90.4	90.1	89.0	0.86	34	7.6	2.7	2.3	420	83	FD 06	75	—	189	64	FA 06	75	430	189	65
22	M 55LA	2	2930	72	●	89.9	89.7	89.5	0.88	40	7.8	2.6	2.4	490	95	FD 06	75	—	189	64	FA 06	75	430	189	65

○ = n.a. ● = IE1





4P **1500 min⁻¹ - S1** **50 Hz**

P _n kW		n min ⁻¹	M _n Nm	IE1	η (100%) %	η (75%) %	η (50%) %	cosφ	In 400V A	Is In %	Ms Mn %	Mia Mn %	J _m x 10 ⁻⁴ kgm ²	IM B5 	freno c.c.						freno c.a.					
															FD			FA			FD			FA		
															Mod	Mb Nm	Z _c 1/h	NB	SB	J _m x 10 ⁻⁴ kgm ²	IM B5 	Mod	Mb Nm	Z _c 1/h	J _m x 10 ⁻⁴ kgm ²	IM B5 
0.09	M 0B	4	1350	0.64	○	51.7	47.6	42.9	0.60	0.42	2.6	2.5	2.4	1.5	2.9	FD 02	1.75	10000	13000	2.6	4.9	FA 02	1.75	13000	2.6	4.7
0.12	M 05A	4	1350	0.85	○	59.8	56.2	47.0	0.62	0.47	2.6	1.9	1.8	2.0	3.2	FD 02	3.5	10000	13000	3.0	5.3	FA 02	3.5	13000	3.0	5.1
0.18	M 05B	4	1320	1.30	○	54.8	52.9	52.5	0.67	0.71	2.6	2.2	2.0	2.3	3.6	FD 02	3.5	7800	10000	3.9	6.5	FA 02	3.5	10000	3.9	6.3
0.25	M 05C	4	1340	1.78	○	65.3	65.0	57.9	0.69	0.80	2.7	2.1	1.9	3.3	4.8	FD 03	5	6000	9400	8.0	8.2	FA 03	5	9400	8.0	7.9
0.37	M 15D	4	1370	2.6	○	66.8	66.7	63.0	0.76	1.05	3.7	2.0	1.9	6.9	5.5	FD 53	7.5	4300	8700	10.2	9.6	FA 03	7.5	8700	10.2	9.3
0.55	M 1LA	4	1380	3.8	○	69.0	68.9	68.8	0.74	1.55	4.1	2.3	2.3	9.1	6.9	FD 04	15	2600	5300	27	14.5	FA 04	15	5300	27	14.4
0.75	M 2SA	4	1400	5.1	●	75.0	74.5	69.3	0.78	1.85	4.9	2.7	2.5	20	9.2	FD 15	26	2800	4900	38	22	FA 15	26	4900	38	23
1.1	M 2SB	4	1400	7.5	●	76.4	76.2	70.4	0.78	2.66	5.1	2.8	2.5	25	10.6	FD 15	40	2600	4700	44	24	FA 15	40	4700	44	24
1.5	M 3SA	4	1410	10.2	●	79.6	80.5	79.3	0.77	3.5	4.6	2.1	2.1	34	15.5	FD 15	40	2400	4400	58	27	FA 15	40	4400	58	28
2.2	M 3LA	4	1410	14.9	●	81.1	81.4	79.9	0.75	5.2	4.5	2.2	2.0	40	17	FD 55	55	—	1300	65	29	FA 15	40	1300	65	30
3	M 3LB	4	1410	20	●	82.6	83.8	83.7	0.77	6.8	5.0	2.3	2.2	54	21	FD 56	75	—	1050	223	55	FA 06	75	1050	223	56
4	M 3LC	4	1400	27	○	82.7	83.1	80.5	0.78	9.0	4.7	2.3	2.2	61	23	FD 06	100	—	950	280	64	FA 07	100	950	280	65
5.5	M 4SA	4	1440	36	●	84.7	84.8	82.5	0.81	11.6	5.5	2.3	2.2	213	42	FD 07	150	—	900	342	73	FA 07	150	900	342	75
7.5	M 4LA	4	1440	50	●	86.0	86.3	85.3	0.81	15.5	5.7	2.5	2.4	270	51	FD 07	150	—	850	382	81	FA 07	150	850	382	83
9.2	M 4LB	4	1440	61	●	88.4	88.6	87.5	0.81	18.8	5.9	2.7	2.5	319	57	FD 08	200	—	750	725	115	FA 08	200	750	725	114
11	M 4LC	4	1440	73	●	87.6	87.8	86.0	0.81	22.4	6.0	2.7	2.5	360	65	FD 08	250	—	700	865	131	FA 08	250	700	865	130
15	M 5SB	4	1460	98	●	88.7	88.5	88.4	0.81	30.1	6.0	2.3	2.1	650	85											
18.5	M 5LA	4	1460	121	●	89.3	89.5	89.2	0.81	37	6.2	2.6	2.5	790	101											

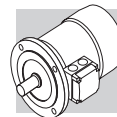
○ = n.a. ● = IE1





2/4P **3000/1500 min⁻¹ - S1** **50 Hz**



P _n kW			n min ⁻¹	M _n Nm	η %	cos φ	I _n 400V A	I _s I _n	M _s M _n	M _a M _n	J _m x 10 ⁻⁴ kgm ²	IM B5 	freno c.c.						freno c.a.					
													FD						FA					
													Mod	Mb Nm	Z ₀ 1/h	NB	SB	J _m x 10 ⁻⁴ kgm ²	IM B5 	Mod	Mb Nm	Z ₀ 1/h	Nim	J _m x 10 ⁻⁴ kgm ²
0.20	0.15	M 05A	2 4	2700 1350	0.71 1.06	55 49	0.82 0.67	3.5 2.6	2.1 1.8	1.9 1.7	2.9 1.7	4.1	FD 02	3.5	2200 4000	2600 5100	5.8	FA 02	3.5	2600 5100	3.5	5.6		
0.28	0.20	M 1SB	2 4	2700 1370	0.99 1.39	56 59	0.82 0.68	2.9 3.1	1.9 1.8	1.7 1.7	4.7	4.0	FD 03	3.5	2100 3800	2400 4800	6.7	FA 03	3.5	2400 4800	5.8	6.4		
0.37	0.25	M 1SC	2 4	2740 1390	1.29 1.72	56 60	0.82 0.73	3.5 3.3	1.8 2.0	1.8 1.9	5.8	4.7	FD 03	5	1400 2900	2100 4200	7.4	FA 03	5	2100 4200	6.9	7.1		
0.45	0.30	M 1SD	2 4	2780 1400	1.55 2.0	63 63	0.85 0.74	3.8 3.8	1.8 2.1	1.8 1.9	6.9	5.5	FD 03	5	1400 2800	2100 4200	8.2	FA 03	5	2100 4200	8.0	7.9		
0.55	0.37	M 1LA	2 4	2800 1400	1.9 2.5	73 68	0.79 0.72	4.2 3.9	2.0 2.2	1.8 2.0	9.1	6.9	FD 03	5	1600 3300	2200 4600	9.6	FA 03	5	2200 4600	10.2	9.3		
0.75	0.55	M 2SA	2 4	2780 1400	2.6 3.8	65 68	0.85 0.81	3.8 3.9	1.9 1.7	1.8 1.7	20	9.2	FD 04	10	1400 2700	1600 3600	13.1	FA 04	10	1600 3600	22	13.0		
1.1	0.75	M 2SB	2 4	2730 1410	3.9 5.1	65 75	0.86 0.81	3.9 4.5	2.0 2.1	1.9 2.0	25	10.7	FD 04	10	1200 2300	1500 3100	14.5	FA 04	10	1500 3100	27	14.5		
1.5	1.1	M 3SA	2 4	2830 1420	5.1 7.4	74 77	0.83 0.78	4.7 4.3	2.1 2.1	2.0 2.0	34	15.5	FD 15	26	700 1600	1000 2600	22	FA 15	26	1000 2600	38	23		
2.2	1.5	M 3LA	2 4	2800 1410	7.5 10.2	72 73	0.85 0.79	4.5 4.7	2.0 2.0	1.9 2.0	40	17	FD 15	26	600 1300	900 2300	24	FA 15	26	900 2300	44	24		
3.5	2.5	M 3LB	2 4	2850 1420	11.7 16.8	80 82	0.84 0.80	5.4 5.2	2.2 2.2	2.1 2.2	61	23	FD 15	40	500 1000	900 2100	29	FA 15	40	900 2100	65	30		
4.8	3.8	M 4 SA	2 4	2900 1430	15.8 25.4	81 81	0.88 0.84	6.0 5.2	2.0 2.1	1.9 2.1	213	42	FD 06	50	— —	400 950	55	FA 06	50	400 950	233	56		
5.5	4.4	M 4SB	2 4	2890 1440	18.2 29	80 82	0.87 0.84	5.9 5.3	2.4 2.2	2.0 2.0	213	42	FD 56	75	— —	350 900	55	FA 06	75	350 900	223	56		
7.5	6	M 4LA	2 4	2900 1430	25 40	82 84	0.87 0.85	6.5 5.8	2.4 2.3	2.0 2.1	270	51	FD 06	100	— —	350 950	64	FA 07	100	350 950	280	65		
9.2	7.3	M 4LB	2 4	2920 1440	30 48	83 85	0.86 0.85	6.0 5.5	2.6 2.3	2.2 2.1	319	57	FD 07	150	— —	300 800	73	FA 07	150	300 800	342	75		



2/6P **3000/1000 min⁻¹ - S3 60/40%** **50 Hz**

P _n kW			n min ⁻¹	M _n Nm	η %	cos φ	I _n 400V A	I _s I _n	M _s M _n	M _a M _n	J _m x 10 ⁻⁴ kgm ²	IM B5  Kg	freno c.c.						freno c.a.						
													FD			FA			FD			FA			
													Mod	Mb Nm	Z ₀ 1/h	NB	SB	Mod	Mb Nm	Z ₀ 1/h	IM B5  Kg	J _m x 10 ⁻⁴ kgm ²	Mod	Mb Nm	Z ₀ 1/h
0.25	M 1SA	2	2850	0.84	60	0.82	0.73	4.3	1.9	1.8	6.9	5.5	FD 03	1.75	1500	1700	10000	8.2	8.0	FA 03	1.75	1700	13000	8.0	7.9
0.08		6	910	0.84	43	0.70	0.38	2.1	1.4	1.5															
0.37	M 1LA	2	2880	1.23	62	0.80	1.08	4.4	1.9	1.8	9.1	6.9	FD 03	3.5	1000	1300	11000	9.6	10.2	FA 03	3.5	1300	10200	10.2	9.3
0.12		6	900	1.27	44	0.73	0.54	2.4	1.4	1.5															
0.55	M 2SA	2	2800	1.88	63	0.86	1.47	4.5	1.9	1.7	20	9.2	FD 04	5	1500	1800	6000	13.1	22	FA 04	5	1800	6000	22	13.0
0.18		6	930	1.85	52	0.65	0.77	3.3	2.0	1.9															
0.75	M 2SB	2	2800	2.6	66	0.87	1.89	4.3	1.8	1.6	25	10.6	FD 04	5	1700	1900	6000	14.5	27	FA 04	5	1900	6000	27	14.4
0.25		6	930	2.6	54	0.67	1.00	3.2	1.7	1.8															
1.1	M 3SA	2	2870	3.7	71	0.82	2.73	4.9	1.8	1.9	34	15.5	FD 15	13	1000	1300	5000	22	38	FA 15	13	1300	5000	38	23
0.37		6	930	3.8	63	0.70	1.21	3.1	1.5	1.8															
1.5	M 3LA	2	2880	5.0	73	0.84	3.53	5.1	1.9	2.0	40	17	FD 15	13	1000	1200	4000	24	44	FA 15	13	1200	4000	44	24
0.55		6	940	5.6	64	0.67	1.85	3.5	1.7	1.8															
2.2	M 3LB	2	2900	7.2	77	0.85	4.9	5.9	2.0	2.0	61	23	FD 15	26	700	900	3000	29	65	FA 15	26	900	3000	65	30
0.75		6	950	7.5	67	0.64	2.5	3.3	1.9	1.8															
3	M 4SA	2	2910	9.9	74	0.88	6.6	5.6	2.0	2.1	170	36	FD 56	37	—	600	2200	48	182	FA 06	37	600	2200	182	50
1.1		6	960	10.9	73	0.68	3.2	4.5	2.2	2.0															
4.5	M 4SB	2	2910	14.8	78	0.84	9.9	5.8	1.9	1.8	213	42	FD 56	37	—	500	2100	55	223	FA 06	37	500	2100	223	56
1.5		6	960	14.9	74	0.67	4.4	4.2	1.9	2.0															
5.5	M 4LA	2	2920	18.0	78	0.87	11.7	6.2	2.1	1.9	270	51	FD 06	50	—	400	1900	64	280	FA 06	50	400	1900	280	65
2.2		6	960	22	77	0.71	5.8	4.3	2.1	2.0															



2/12P		3000/500 min ⁻¹ - S3 60/40%														50 Hz						
		freno c.c.														freno c.a.						
		P _n kW		n min ⁻¹	M _n Nm	η %	cos φ	I _n 400V A	I _s I _n	M _s M _n	M _a M _n	J _m x 10 ⁻⁴ kgm ²	IM B5  Kg	Mod	Mb Nm	FD		FA				
Z _o 1/h	NB															SB	Z _o 1/h	Mod	Mb Nm	J _m x 10 ⁻⁴ kgm ²	IM B5  Kg	
0.55	M 2SA	2	1.86	64	0.89	1.39	4.2	1.6	1.7	25	10.6	FD 04	5	1000	1300	14.5	FA 04	5	1300	27	27	14.4
0.09		12	2.0	30	0.63	0.69	1.8	1.9	1.8		8000			8000	12000							
0.75	M 3SA	2	2.5	65	0.81	2.06	5.2	1.9	2.1	34	15.5	FD 15	13	700	900	22	FA 15	13	900	38	38	23
0.12		12	2.5	33	0.43	1.22	1.9	1.3	1.6		5000			5000	7000							
1.1	M 3LA	2	3.7	65	0.85	2.87	4.5	1.6	1.8	40	17	FD 15	13	700	900	24	FA 15	13	900	44	44	24
0.18		12	4.0	26	0.54	1.85	1.5	1.3	1.5		4000			4000	6000							
1.5	M 3LB	2	4.9	67	0.86	3.76	5.6	1.9	1.9	54	21	FD 15	13	700	900	27	FA 15	13	900	58	58	28
0.25		12	5.4	36	0.46	2.18	1.8	1.7	1.8		3800			3800	5000							
2	M 3LC	2	6.7	70	0.84	4.9	4.9	1.8	1.7	61	23	FD 55	18	—	700	29	FA 15	18	700	65	65	30
0.3		12	6.4	38	0.47	2.4	1.7	1.6	1.7		—			—	3500							
3	M 4SA	2	9.8	74	0.87	6.7	6.8	2.3	1.9	213	42	FD 56	37	—	450	55	FA 06	37	450	223	223	56
0.5		12	10.2	51	0.43	3.3	2.0	1.7	1.6		—			—	3000							
4	M 4LA	2	13.1	75	0.89	8.6	5.9	2.4	2.3	270	51	FD 56	37	—	400	64	FA 06	37	400	280	280	65
0.7		12	14.5	53	0.44	4.3	1.9	1.7	1.6		—			—	2800							



M11 DIMENSIONES MOTORES

BN - IM B5

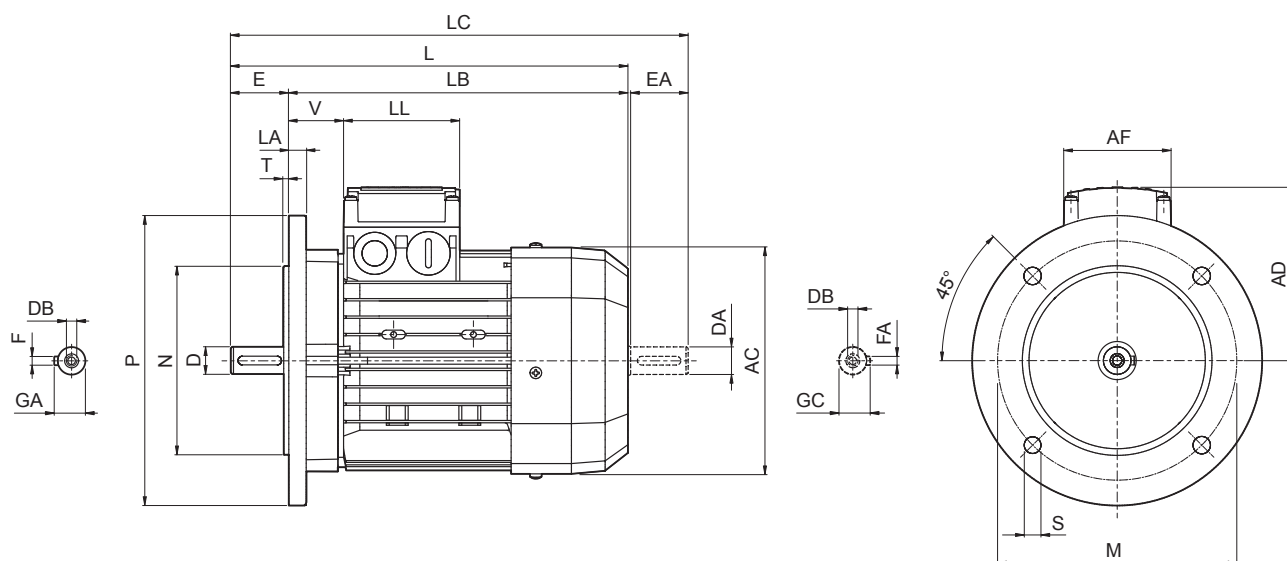

	Eje					Brida					Motor								
	D DA	E EA	DB	GA GC	F FA	M	N	P	S	T	LA	AC	L	LB	LC	AD	AF	LL	V
BN 56	9	20	M3	10.2	3	100	80	120	7	3	8	110	185	165	207	91	74	80	34
BN 63	11	23	M4	12.5	4	115	95	140	9.5		10	121	207	184	232	95			26
BN 71	14	30	M5	16	5	130	110	160			10	138	249	219	281	108			37
BN 80	19	40	M6	21.5	6	165	130	200	11.5	3.5	11.5	156	274	234	315	119	98	98	38
BN 90	24	50	M8	27	8						176	326	276	378	133	44			
BN 100	28	60	M10	31	8	215	180	250	14	4	14	195	367	307	429	142	98	98	50
BN 112											15	219	385	325	448	157			52
BN 132	38	80	M12	41	10	265	230	300	18.5	5	20	258	493	413	576	193	118	118	58
BN 160 MR	42 38 ⁽¹⁾	110 80 ⁽¹⁾	M16 M12 ⁽¹⁾	45 41 ⁽¹⁾	12 10 ⁽¹⁾	300	250	350			15		310	596	486				680
BN 160 M									48 38 ⁽¹⁾	110 110 ⁽¹⁾	M16 M16 ⁽¹⁾	51.5 41 ⁽¹⁾	14 10 ⁽¹⁾	300	250	350	15	310	640
BN 160 L	48 42 ⁽¹⁾	110 110 ⁽¹⁾	M16 M16 ⁽¹⁾	51.5 45 ⁽¹⁾	14 12 ⁽¹⁾	300	250	350									18	348	708
BN 180 M									55 42 ⁽¹⁾	110 110 ⁽¹⁾	M20 M16 ⁽¹⁾	59 45 ⁽¹⁾	16 12 ⁽¹⁾	350	300	400	18	348	722
BN 180 L	55 42 ⁽¹⁾	110 110 ⁽¹⁾	M20 M16 ⁽¹⁾	59 45 ⁽¹⁾	16 12 ⁽¹⁾	350	300	400									18	348	722
BN 200 L									55 42 ⁽¹⁾	110 110 ⁽¹⁾	M20 M16 ⁽¹⁾	59 45 ⁽¹⁾	16 12 ⁽¹⁾	350	300	400	18	348	722

N.B.:

1) Estas dimensiones están referidas a la segunda extremidad del eje.



BN - IM B14

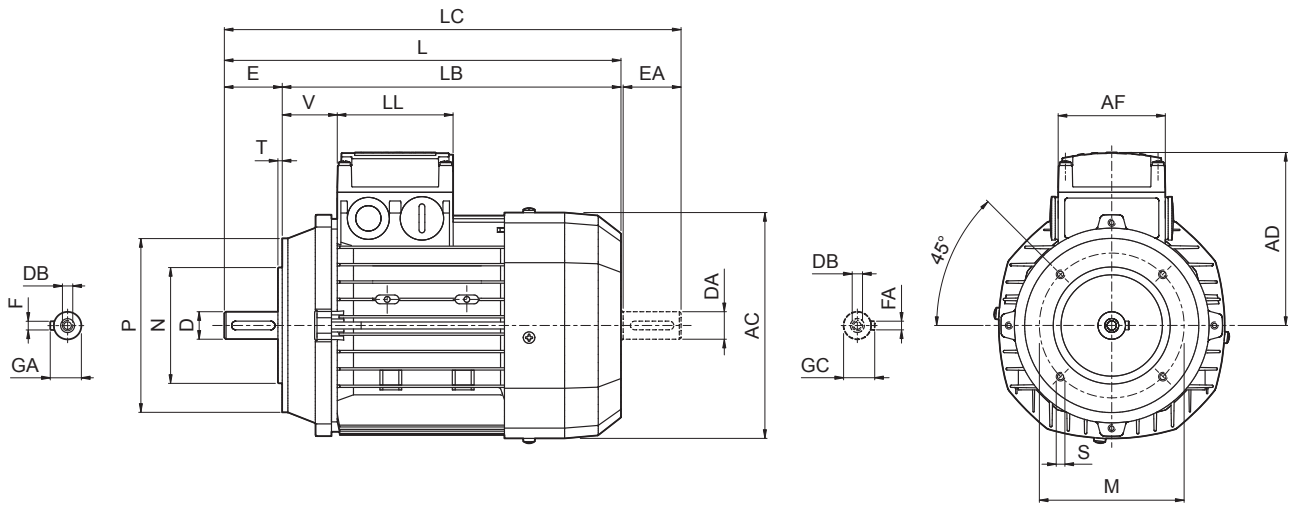

	Eje					Brida					Motor							
	D DA	E EA	DB	GA GC	F FA	M	N	P	S	T	AC	L	LB	LC	AD	AF	LL	V
BN 56	9	20	M3	10.2	3	65	50	80	M5	2.5	110	185	165	207	91	74	80	34
BN 63	11	23	M4	12.5	4	75	60	90			121	207	184	232	95			26
BN 71	14	30	M5	16	5	85	70	105	M6		138	249	219	281	108			37
BN 80	19	40	M6	21.5	6	100	80	120		3	156	274	234	315	119	38		
BN 90	24	50	M8	27	8	115	95	140	M8		3.5	176	326	276	378	133	98	98
BN 100	28	60	M10	31		130	110	160		195		367	307	429	142	50		
BN 112					219	385	325	448	157	52								
BN 132	38	80	M12	41	10	165	130	200	M10	4	258	493	413	576	193	118	118	58



BN_FD ; IM B5

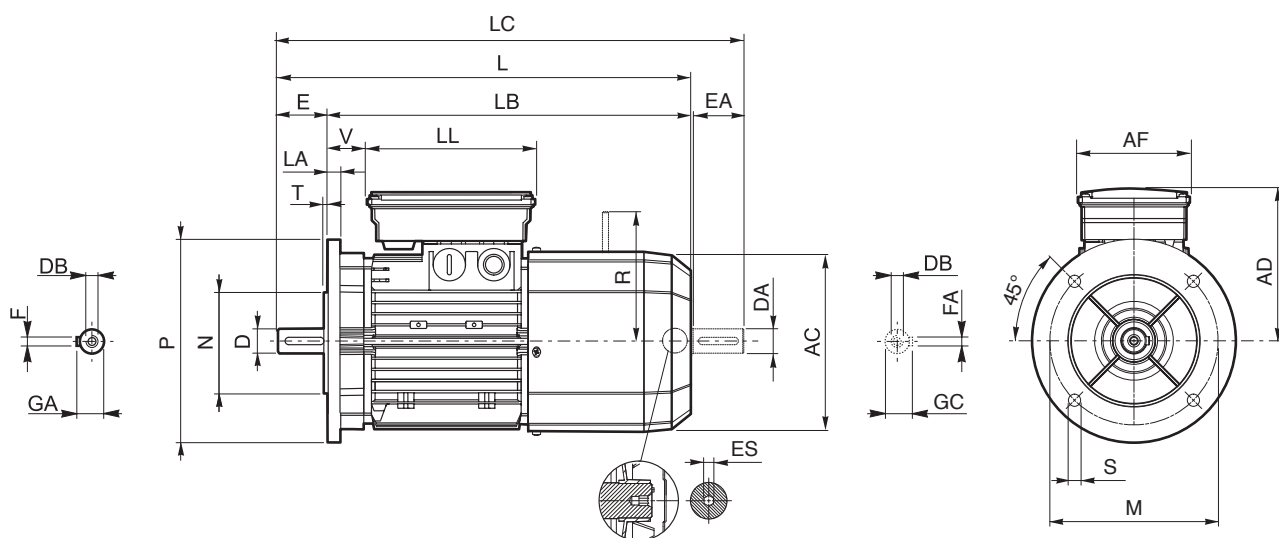

	Eje					Brida					Motor										
	D DA	E EA	DB	GA GC	F FA	M	N	P	S	T	LA	AC	L	LB	LC	AD	AF	LL	V	R	ES
BN 63	11	23	M4	12.5	4	115	95	140	9.5	3	10	121	272	249	297	122	98	133	14	96	5
BN 71	14	30	M5	16	5	130	110	160	9.5	3.5		138	310	280	342	135			25	103	
BN 80	19	40	M6	21.5	6	165	130	200	11.5			156	346	306	388	146			41	129	
BN 90 S	24	50	M8	27	8					215	180	250	14	4	176	409	359	461	149	110	165
BN 90 L						146	62	199													
BN 100	28	60	M10	31	10	265	230	300	14	4	14	195	458	398	521	158	140	188	46	204 ⁽²⁾	6
BN 112											15	219	484	424	547	173			62	199	
BN 132	38	80	M12	41	10	300	250	350	18.5	5	20	258	603	523	686	210	140	188	46	204 ⁽²⁾	
BN 160 MR	42	110	M16	45	12						300		250	350	18.5				5	15	310
BN 160 M	38 ⁽¹⁾					736	626	820	51	266											
BN 160 L	42					780	670	864	51	266											
BN 180 M	48	110	M16	51.5	14	350	300	400	18.5	5	18	348	866	756	981	261	187	187	52	305	
BN 180 L	48												878	768	993				64		
BN 200 L	55												878	768	993				64		

N.B.:

1) Estas dimensiones están referidas a la segunda extremidad del eje.

2) Para el freno FD07 la cota R = 226

El taladro hexagonal ES no está presente en la opción PS.



BN_FD ; IM B14

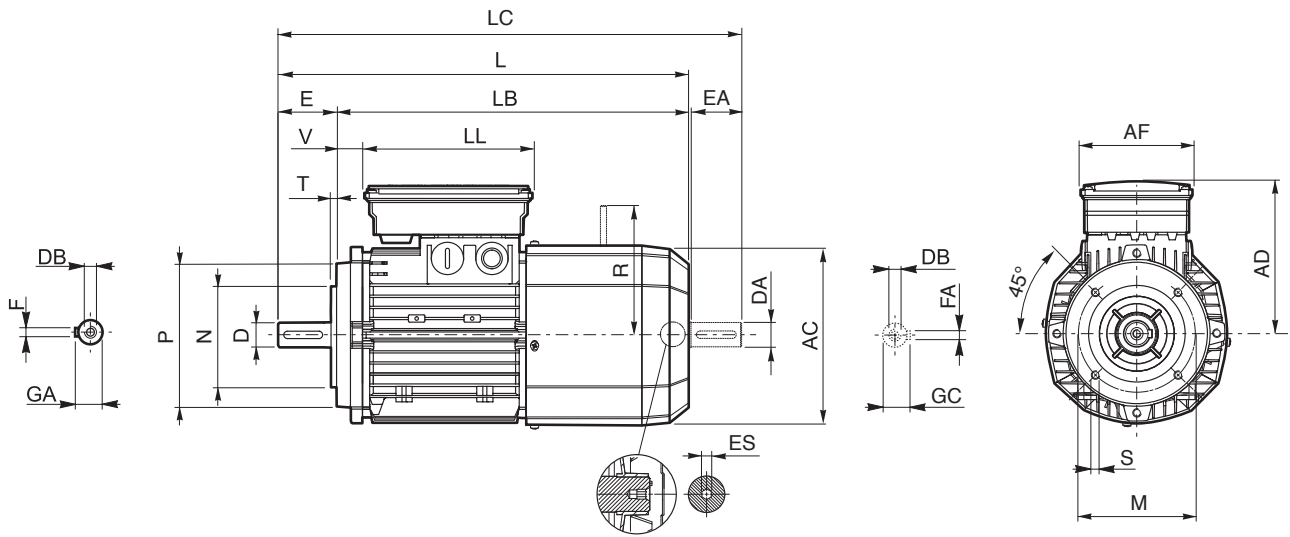

	Eje					Brida					Motor									
	D DA	E EA	DB	GA GC	F FA	M	N	P	S	T	AC	L	LB	LC	AD	AF	LL	V	R	ES
BN 63	11	23	M4	12.5	4	75	60	90	M5	2.5	121	272	249	297	122	98	133	14	96	5
BN 71	14	30	M5	16	5	85	70	105	M6		138	310	280	342	135			25	103	
BN 80	19	40	M6	21.5	6	100	80	120			156	346	306	388	146			41	129	
BN 90 S	24	50	M8	27	8	115	95	140	M8	3	176	409	359	461	149	110	165	39	129	6
BN 90 L																			146	
BN 100	28	60	M10	31	130	110	160	M8	3.5	195	458	398	521	158	173	110	165	62	199	6
BN 112																		73	199	
BN 132	38	80	M12	41	10	165	130	200	M10	4	258	603	523	686	210	140	188	46	204 ⁽¹⁾	

N.B.:

1) Para el freno FD07 la cota R = 226

El taladro hexagonal ES no está presente en la opción PS.



BN_FA - IM B5

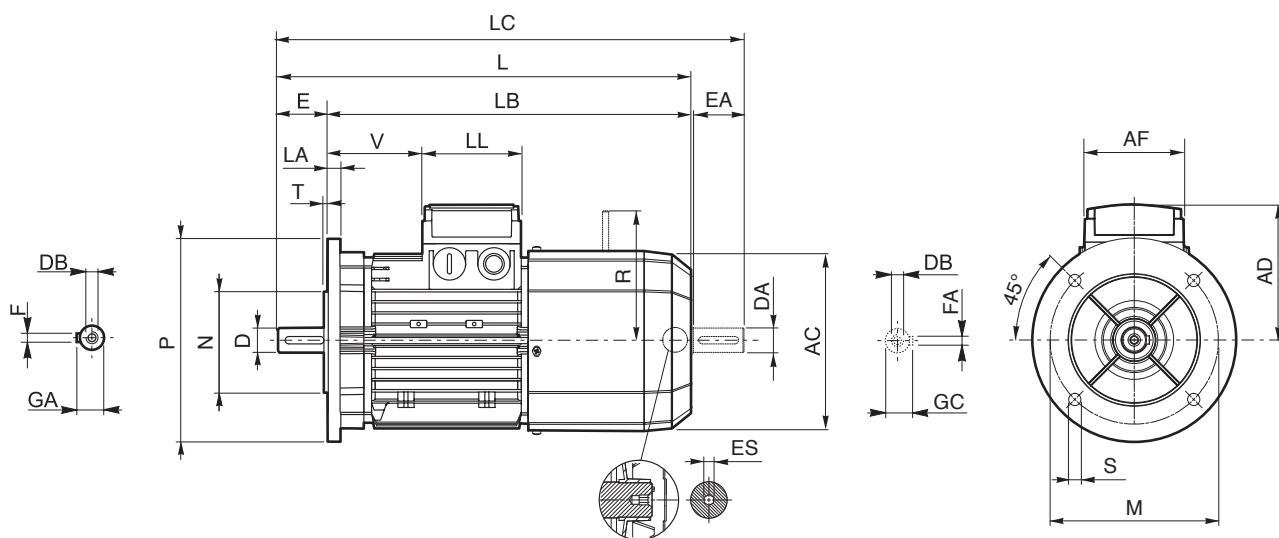

	Eje					Brida						Motor										
	D DA	E EA	DB	GA GC	F FA	M	N	P	S	T	LA	AC	L	LB	LC	AD	AF	LL	V	R	ES	
BN 63	11	23	M4	12.5	4	115	95	140	9.5	3	10	121	272	249	297	95	74	80	26	116	5	
BN 71	14	30	M5	16	5	130	110	160				138	310	280	342	108			68	124		
BN 80	19	40	M6	21.5	6	165	130	200	11.5	3.5	11.5	156	346	306	388	119	98	98	83	134	6	
BN 90	24	50	M8	27	176							409	359	461	133	95			160			
BN 100	28	60	M10	31	8	215	180	250	14	4	14	195	458	398	521	142	119	128	198	200 ⁽²⁾		
BN 112												15	219	484	424	547					157	
BN 132	38	80	M12	41	10	265	230	300	14	5	15	20	603	523	686	210	140	188	46	217		
BN 160 MR	42 38 ⁽¹⁾	110 80 ⁽¹⁾	M16 M12 ⁽¹⁾	45 41 ⁽¹⁾	12 10 ⁽¹⁾	300	250	350				18.5									5	15
BN 160 M									310	736	626		820	245	187	187	51	247				
BN 160 L	780	670	864																			
BN 180 M	48 38 ⁽¹⁾			51.5 41 ⁽¹⁾	14 10 ⁽¹⁾																	—

N.B.:

- 1) Estas dimensiones están referidas a la segunda extremidad del eje.
- 2) Para el freno FA07 la cota R = 217

Las dimensiones AD, AF, LL y V relativas a la caja de bornes de los motores BN...FA con alimentación separada (opción SA) son iguales a las de los motores BN...FD del mismo tamaño.

El taladro hexagonal ES no está presente en la opción PS.



BN_FA - IM B14

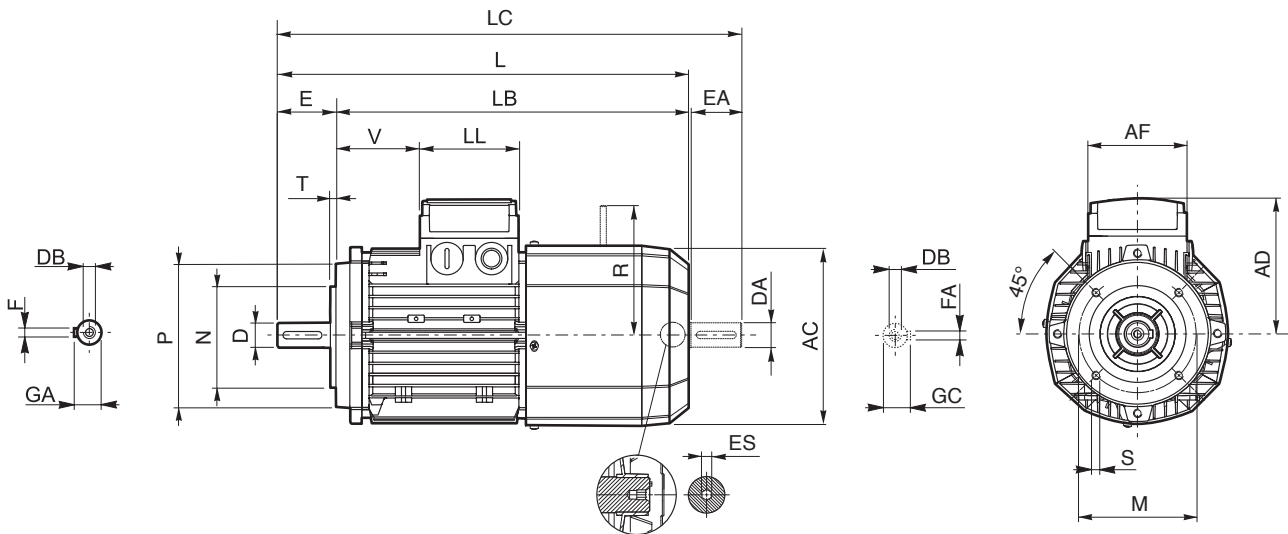

	Eje					Brida					Motor									
	D DA	E EA	DB	GA GC	F FA	M	N	P	S	T	AC	L	LB	LC	AD	AF	LL	V	R	ES
BN 63	11	23	M4	12.5	4	75	60	90	M5	2.5	121	272	249	119	95	74	80	26	116	5
BN 71	14	30	M5	16	5	85	70	105	M6		138	310	280	342	108			68	124	
BN 80	19	40	M6	21.5	6	100	80	120		3	156	346	306	388	119			83	134	
BN 90	24	50	M8	27	8	115	95	140	M8	3.5	176	409	359	461	133	98	98	95	160	6
BN 100	28	60	M10	31		130	110	160			195	458	398	521	142			119	198	
BN 112												219	484	424	547			157	128	
BN 132	38	80	M12	41	10	165	130	200	M10	4	258	603	523	686	210	140	188	46	200 ⁽¹⁾	

N.B.:

1) Para el freno FA07 la cota R = 217.

Las dimensiones AD, AF, LL y V relativas a la caja de bornes de los motores BN...FA con alimentación separada (opción SA) son iguales a las de los motores BN...FD del mismo tamaño.

El taladro hexagonal ES no está presente en la opción PS.



M

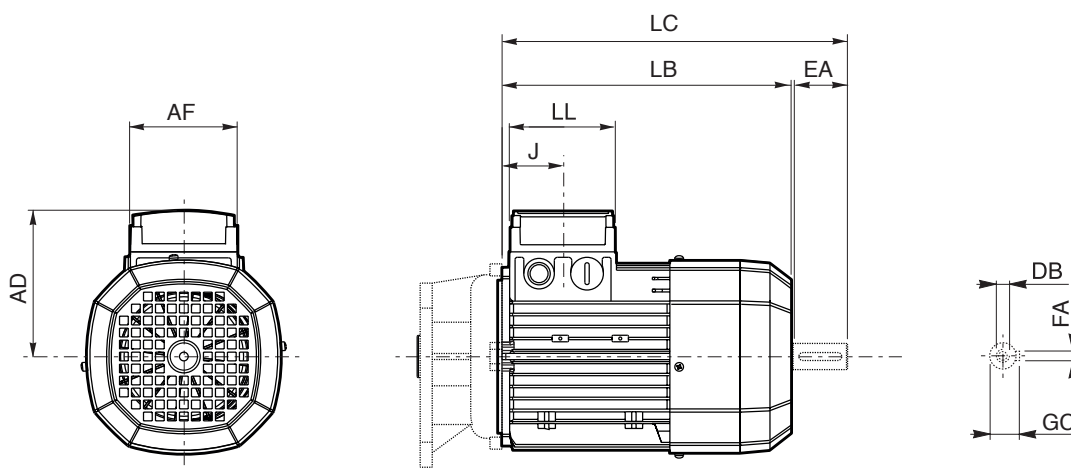

	Segunda extremidad del eje					Motor						
	DA	EA	DB	FA	GC	AC	LB	LC	AF	LL	J	AD
M 0	9	20	M3	3	10.2	110	133	155	74	80	42	91
M 05	11	23	M4	4	12.5	121	165	191			48	95
M 1	14	30	M5	5	16	138	187	219			45	108
M 2 S	19	40	M6	6	21.5	156	202	245			44	119
M 3 S	28	60	M10	8	31	195	230	293	98	98	53.5	142
M 3 L							262	325				
M 4	38	80	M12	10	41	258	361	444	118	118	64.5	193
M 4 LC							396	479				
M 5 S						310	418	502	187	187	77	245
M 5 L							462	546				



M_FD

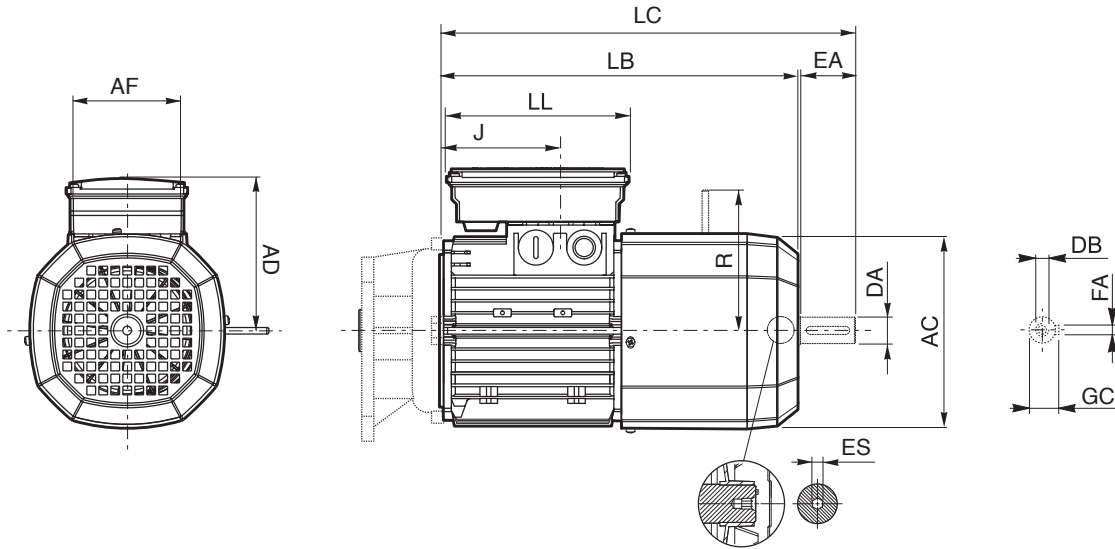

	Segunda extremidad del eje					Motor								
	DA	EA	DB	FA	GC	AC	LB	LC	AF	LL	J	AD	R	ES
M 05	11	23	M4	4	12.5	121	231	256	98	133	48	122	96	5
M 1	14	30	M5	5	16	138	248	280			73	135	103	
M 2 S	19	40	M6	6	21.5	156	272	314			88	146	129	
M 3 S	28	60	M10	8	31	195	326	389	110	165	124.5	158	160	6
M 3 L							353	416						
M 4	38	80	M12	10	41	258	470	553	140	188	185.5	210	204 (1)	
M 4 LC							495	578			64.5		226	
M 5 S						310	558	642	187	187	77	245	266	
M 5 L							602	686						

N.B.:

1) Para el freno FD07 la cota R = 226

El taladro hexagonal ES no está presente en la opción PS.



M_FA

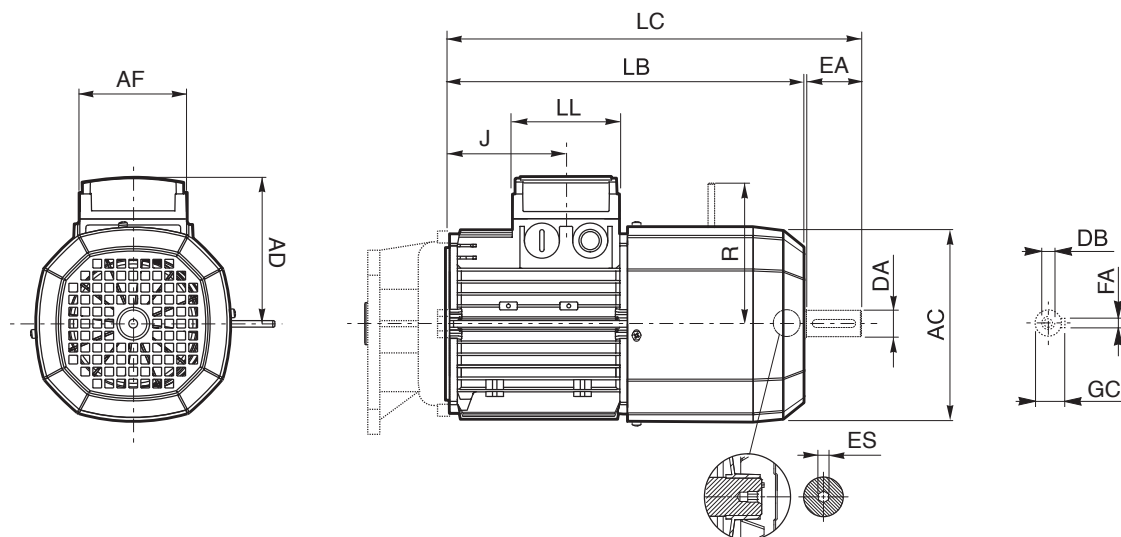

	Segunda extremidad del eje					Motor								
	DA	EA	DB	FA	GC	AC	LB	LC	AF	LL	J	AD	R	ES
M 05	11	23	M4	4	12.5	121	231	256	74	80	48	95	116	5
M 1	14	30	M5	5	16	138	248	280			73	108	124	
M 2 S	19	40	M6	6	21.5	156	272	314			88	119	134	
M 3 S	28	60	M10	8	31	195	326	389	98	98	124.5	142	160	6
M 3 L							353	416						
M 4	38	80	M14	10	41	258	470	553	140	188	185.5	210	200 (1)	
M 4 LC							495	578			64.5		217	
M 5 S			M12			310	558	642	187	187	77	245	247	—
M 5 L														

N.B.:

1) Para el freno FA07 la cota R = 217.

Las dimensiones AD, AF, LL y V relativas a la caja de bornes de los motores M..FA con alimentación separada (opción SA) son iguales a las de los motores M...FD del mismo tamaño.

El taladro hexagonal ES no está presente en la opción PS.



ÍNDICE DE REVISIONES

BR_CAT_VFW_STD_SPA_R11_3	
	Descripción
97	Actualizada la tabla "Predisposiciones motor" para reductores VF/VF 30/44 y VF/VF 30/49.
111	Correctas las características del motor eléctrico BN27.
138...141	Correcta la dimensión del orificio de fijación para los reuctores W110.
185	Dimensiones correctas para reductores VF 44L y VF 49L.

2023.06.09

Esta publicación anula y sustituye a todas las ediciones o revisiones anteriores. Nos reservamos el derecho a modificarla sin previo aviso. Está prohibida la reproducción, total o parcial, sin autorización.



Nuestro compromiso con la excelencia, la innovación y la sostenibilidad es firme. Nuestro equipo crea, distribuye y repara soluciones de transmisión de potencia y accionamiento de categoría mundial para que el mundo siga en movimiento.

CASA MATRIZ

Bonfiglioli S.p.A

Sede legal: Via Cav. Clementino Bonfiglioli, 1
40012 Calderara di Reno - Bologna (Italy)
Tel. +39 051 6473111

Sede operativa: Via Isonzo, 65/67/69
40033 Casalecchio di Reno - Bologna (Italy)

