

BONFIGLIOLI

eVOX INCLUDED  
PLATFORM

# SERIE VF-W

## IE2-IE3

Riduttori a vite senza fine

 **Bonfiglioli**





Parag.	Descrizione	Pagina	Parag.	Descrizione	Pagina
<b>INFORMAZIONI GENERALI</b>			<b>VF-EP / W-EP - RIDUTTORI E MOTORIDUTTORI PER AMBIENTI CORROSIVI E ASETTICI</b>		
		<b>2</b>			<b>197</b>
1	Simbologia e unità di misura	2	33	I vantaggi dell'esecuzione EP per l'industria	197
2	Definizioni	3	34	Designazione	200
3	Temperature limite ammesse	6	35	Opzioni riduttore	202
4	Selezione	7	36	Opzioni motori	202
5	Verifiche	9	37	Altre informazioni sui riduttori e i motoriduttori	203
6	Installazione	9	38	Gli accessori della serie EP	203
7	Lubrificazione	11			
8	Stoccaggio	12			
9	Condizioni di fornitura	12			
<b>RIDUTTORI A VITE SENZA FINE</b>			<b>DISPOSITIVO FINE-CORSA RVS</b>		
		<b>13</b>			<b>205</b>
10	Caratteristiche costruttive	13	39	Informazioni generali	205
11	Forme costruttive	14	40	Codici per l'ordinamento	206
12	Esecuzione di montaggio	15	41	Designazione	207
13	Designazione	18	42	Tabelle di selezione motoriduttore	208
14	Opzioni riduttore	20	43	Dimensioni	210
15	Posizioni di montaggio e orientamento morsettiera	25	44	Opzioni	214
16	Carichi radiali	34			
17	Carichi assiali	35	<b>ELECTRIC MOTORS</b>		
18	Rendimento	38			<b>215</b>
19	Irreversibilità	38	M1	Simbologia e unità di misura	215
20	Giochi angolari	40	M2	Introduzione	216
21	Dati tecnici motoriduttori	41	M3	Caratteristiche generali	218
22	Tabelle dati tecnici riduttori	82	M4	Designazione motore	220
23	Combinazioni dei rapporti nei riduttori combinati serie VF/VF, VF/W, W/VF	104	M5	Varianti e Opzioni	224
24	Predisposizioni motore	105	M6	Caratteristiche meccaniche	227
25	Momento d'inerzia	108	M7	Caratteristiche elettriche	232
26	Dimensioni motoriduttori e riduttori predisposti IEC	121	M8	Motori asincroni autofrenanti	244
27	Dimensioni riduttori con ingresso HS	187	M9	Motori autofrenanti in c.c., tipo BN_FD e M_FD	245
28	Dimensioni riduttori con braccio di reazione	191	M10	Motori autofrenanti in c.a., tipo BN_FA e M_FA	251
29	Dimensioni riduttori con cappello di reazione	191	M11	Sistemi di sblocco freno	255
30	Accessori	192	M12	Opzioni	257
31	Albero cliente	193	M13	Tabelle di correlazione motori	271
32	Limitatore di coppia	194	M14	Dati tecnici motori BXN-MXN	274
			M15	Dimensioni motori BXN-MXN	276
			M16	Dati tecnici motori BX-MX	282
			M17	Dimensioni motori BX-MX	289
			M18	Dati tecnici motori BE-ME	301
			M19	Dimensioni motori BE-ME	315
			M20	Dati tecnici motori BN-M	321
			M21	Dimensioni motori BN-M	338

#### Revisioni

L'indice di revisione del catalogo è riportato a pag. 348. Al sito [www.bonfiglioli.com](http://www.bonfiglioli.com) sono disponibili i cataloghi con le revisioni aggiornate.



## INFORMAZIONI GENERALI

### 1 SIMBOLOGIA E UNITÀ DI MISURA

Simbolo	Unità di misura	Descrizione	Simbolo	Unità di misura	Descrizione
$A_{N 1,2}$	[N]	Carico assiale nominale	$n_{1,2}$	[min <sup>-1</sup> ]	Velocità
$f_s$	–	Fattore di servizio	$P_{1,2}$	[kW]	Potenza
$f_T$	–	Fattore termico	$P_{N 1,2}$	[kW]	Potenza nominale
$f_{TP}$	–	Fattore di temperatura	$P_{R 1,2}$	[kW]	Potenza richiesta
$i$	–	Rapporto di trasmissione	$R_{C 1,2}$	[N]	Carico radiale di calcolo
$I$	–	Rapporto di intermittenza	$R_{N 1,2}$	[N]	Carico radiale nominale
$J_C$	[Kgm <sup>2</sup> ]	Momento di inerzia carico	$S$	–	Fattore di sicurezza
$J_M$	[Kgm <sup>2</sup> ]	Momento di inerzia motore	$t_a$	[°C]	Temperatura ambiente
$J_R$	[Kgm <sup>2</sup> ]	Momento di inerzia riduttore	$t_s$	[°C]	Temperatura superficiale
$K$	–	Fattore di accelerazione delle masse	$t_o$	[°C]	Temperatura olio
$K_r$	–	Costante di trasmissione	$t_f$	[min]	Tempo di funzionamento a carico costante
$M_{1,2}$	[Nm]	Coppia	$t_r$	[min]	Tempo di riposo
$M_{C 1,2}$	[Nm]	Coppia di calcolo	$\eta_d$	–	Rendimento dinamico
$M_{n 1,2}$	[Nm]	Coppia nominale	$\eta_s$	–	Rendimento statico
$M_{r 1,2}$	[Nm]	Coppia richiesta			

<sub>1</sub> valore riferito all'albero veloce

<sub>2</sub> valore riferito all'albero lento



Questo simbolo indica informazioni tecniche di particolare importanza da non trascurare.



Questo simbolo riporta i riferimenti angolari per l'indicazione della direzione del carico radiale (l'albero è visto di fronte).



Questo simbolo indica situazioni di grave pericolo che, se trascurate, possono mettere seriamente a rischio la salute e la sicurezza delle persone.



Simbolo riferito al peso dei riduttori e dei motoriduttori. I valori riportati nelle tabelle dei motoriduttori sono comprensivi sia del peso del motore a 4 poli sia del peso del lubrificante contenuto, qualora previsto da BONFIGLIOLI RIDUTTORI.



Il simbolo identifica la pagina alla quale può essere reperita l'informazione.

## 2 DEFINIZIONI

### 2.1 COPPIA

#### **Coppia nominale $M_{n2}$ [Nm]**

È la coppia trasmissibile in uscita con carico continuo uniforme, riferita alla velocità in ingresso  $n_1$  e a quella corrispondente in uscita  $n_2$ .

È calcolata in base ad un fattore di servizio  $f_s = 1$ .

#### **Coppia richiesta $M_{r2}$ [Nm]**

Rappresenta la coppia richiesta dall'applicazione e dovrà sempre essere uguale o inferiore alla coppia in uscita nominale  $M_{n2}$  del riduttore.

#### **Coppia di calcolo $M_{c2}$ [Nm]**

È il valore di coppia da utilizzare per la selezione del riduttore considerando la coppia richiesta  $M_{r2}$  e il fattore di servizio  $f_s$  ed è dato dalla formula:

$$M_{c2} = M_{r2} \times f_s \leq M_{n2} \quad (1)$$

### 2.2 POTENZA

#### **Potenza nominale in entrata $P_{n1}$ [kW]**

Il parametro è riscontrabile nelle tabelle dei dati tecnici nominali e rappresenta la potenza applicabile al riduttore in relazione alla velocità di comando  $n_1$  e al fattore di servizio  $f_s = 1$ .



## 2.3 RENDIMENTO

### Rendimento dinamico [ $\eta_d$ ]

Si definisce come il rapporto fra la potenza in uscita  $P_2$  e quella in entrata  $P_1$ :

$$\eta_d = \frac{P_2}{P_1} \quad (2)$$

È opportuno evidenziare che i valori di coppia nominale  $M_{n2}$  sono calcolati tenendo conto del rendimento dinamico  $\eta_d$  che si produce al termine della fase di rodaggio dei riduttori.

Dopo il rodaggio si ha anche una riduzione e infine una stabilizzazione della temperatura di funzionamento. La temperatura sotto carico è influenzata dal tipo di servizio e dalla temperatura ambiente, riferirsi al capitolo "TEMPERATURE LIMITE AMMESSE" per indicazioni sui valori consentiti. Se c'è motivo di attendersi temperature di funzionamento vicine al limite massimo consentito, è opportuno equipaggiare il riduttore di anelli di tenuta in fluoro-elastomero, specificando nell'ordinativo l'opzione **PV**.

### Rendimento statico [ $\eta_s$ ]

È il rendimento applicabile all'avviamento del riduttore. Il parametro non è generalmente rilevante nel caso di ingranaggi elicoidali, ma deve essere tenuto in particolare considerazione nella scelta di motorizzazioni a vite senza fine, quando questi operano con un tipo di servizio intermittente (es. Sollevamenti).

## 2.4 RAPPORTO DI RIDUZIONE [ $i$ ]

Il valore del rapporto di riduzione della velocità, identificato con il simbolo [  $i$  ], è espresso tramite il rapporto fra le velocità all'albero veloce e lento del riduttore e riassunto nell'espressione:

$$i = \frac{n_1}{n_2} \quad (3)$$

## 2.5 MOMENTO D'INERZIA $J_r$ [kgm<sup>2</sup>]

I momenti d'inerzia indicati a catalogo sono riferiti all'albero veloce del riduttore e pertanto, nell'accoppiamento con un motore elettrico, il loro valore si somma semplicemente a quello del motore stesso.



## 2.6 FATTORE DI SERVIZIO [ $f_s$ ]

Il fattore di servizio è il parametro che traduce in un valore numerico la gravosità del servizio che il riduttore è chiamato a svolgere, tenendo conto, benché con inevitabile approssimazione, del funzionamento giornaliero, della variabilità del carico e di eventuali sovraccarichi, connessi con la specifica applicazione del riduttore. Nel grafico seguente riportato il fattore di servizio si ricava, dopo aver selezionato la colonna relativa alle ore di funzionamento giornaliero, per intersezione fra il numero di avviamenti orari e una fra le curve K1, K2 e K3.

Le curve  $K$  sono associate alla natura del servizio (approssimativamente: uniforme, medio e pesante) tramite il fattore di accelerazione delle masse  $K$ , legato al rapporto fra le inerzie delle masse condotte e del motore. Indipendentemente dal valore così ricavato del fattore di servizio, segnaliamo che esistono applicazioni fra le quali, a puro titolo di esempio i sollevamenti, per le quali il cedimento di un organo del riduttore potrebbe esporre il personale che opera nelle immediate vicinanze a rischio di ferimento. Se esistono dubbi che l'applicazione possa presentare questa criticità vi invitiamo a consultare preventivamente il ns. Servizio Tecnico.

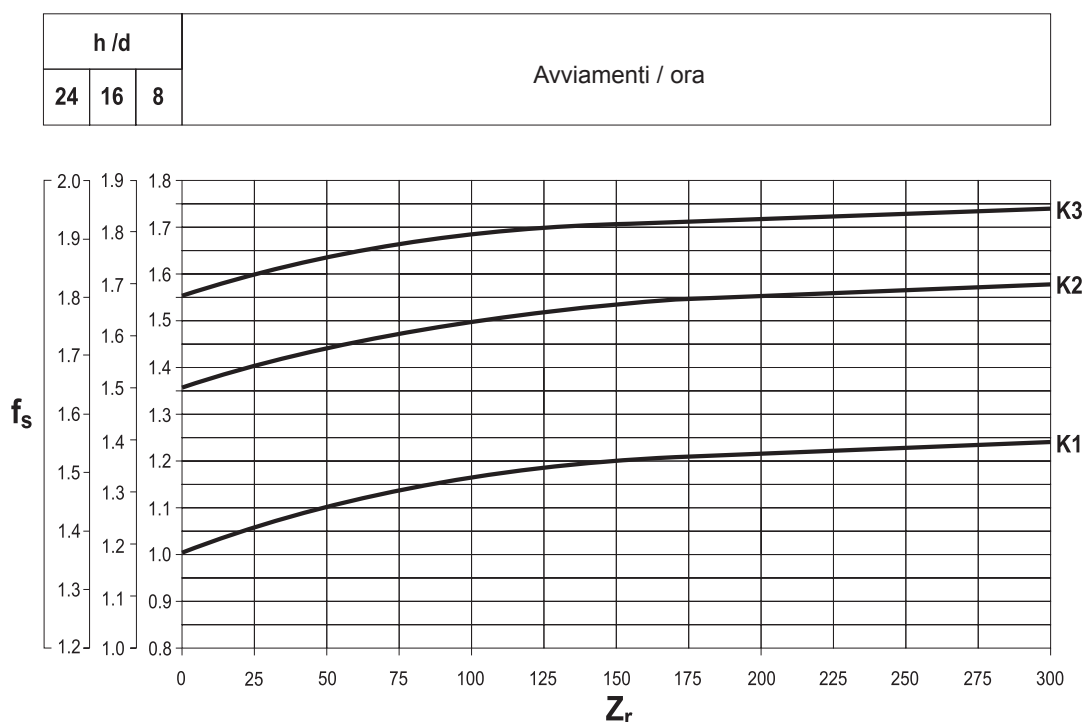

### Fattore di accelerazione delle masse, [ $K$ ]

Il parametro serve a selezionare la curva relativa al particolare tipo di carico. Il valore è dato dal rapporto:

$$K = \frac{J_c}{J_m} \quad (4)$$

$K = \frac{J_c}{J_m}$	→	$J_c =$ Momento d'inerzia delle masse comandate, riferito all'albero motore
		$J_m =$ Momento d'inerzia del motore

$K \leq 0,25$	→	<b>K1</b> Carico uniforme
$0,25 < K \leq 3$	→	<b>K2</b> Carico con urti moderati
$3 < K \leq 10$	→	<b>K3</b> Carico con forti urti
$K > 10$	→	Consultare il Servizio Tecnico di Bonfiglioli



### 3 TEMPERATURE LIMITE AMMESSE

Simbolo	Descrizione / Condizione	Valore (*)	
		Olio Sintetico	Olio Minerale
$t_a$	Temperatura ambiente		
$t_{au \text{ min}}$	Temperatura ambiente minima di utilizzo	-30°C	-10°C
$t_{au \text{ Max}}$	Temperatura ambiente massima di utilizzo	+50°C	+40°C
$t_{as \text{ min}}$	Temperatura ambiente minima di stoccaggio	-40°C	-10°C
$t_{as \text{ Max}}$	Temperatura ambiente massima di stoccaggio	+50°C	+50°C
$t_s$	Temperatura superficiale		
$t_{s \text{ min}}$	Temperatura minima superficiale del riduttore per avviamento con carico parziale (#)	-25°C	-10°C
$t_{sc \text{ min}}$	Temperatura minima superficiale del riduttore per avviamento a pieno carico	-10°C	-5°C
$t_{s \text{ Max}}$	Temperatura massima superficiale della cassa per utilizzo in modalità di funzionamento continuo a regime (rilevata in prossimità della zona veloce in entrata)	+100°C	+100°C (@)
$t_o$	Temperatura dell'olio		
$t_{o \text{ Max}}$	Temperatura massima dell'olio per utilizzo in modalità di funzionamento continuo a regime	+95°C	+95°C (@)

(\*) = Per i valori minimi e massimi specifici per le diverse viscosità d'olio riferirsi alla tabella "Scelta della viscosità ottimale dell'olio". Per i valori di  $t_a < -20^\circ\text{C}$  e  $t_s, t_o > 80^\circ\text{C}$ , scegliere (per quanto consentito in fase di configurazione prodotto) la tipologia di tenuta nel materiale più idoneo al tipo di applicazione. Se necessario contattare il Servizio Tecnico Bonfiglioli.

(@) = Per i valori di  $t_s, t_o > 80^\circ\text{C}$  e  $< 95^\circ\text{C}$ , è sconsigliato l'utilizzo per funzionamenti in continuo.

(#) = Per l'avviamento a pieno carico è consigliabile l'uso di una rampa graduale e prevedere un maggior assorbimento del motore. Se necessario contattare il Servizio Tecnico Bonfiglioli.





## 4 SELEZIONE

### 4.1 Selezione di un motoriduttore

a) Determinare il fattore di servizio  $f_s$  come precedentemente Descritto.

b) Ricavare la potenza richiesta all'albero veloce del riduttore.

$$P_{r1} = \frac{M_{r2} \times n_2}{9550 \times \eta_d} \quad [\text{kW}] \quad (5)$$

c) Nel capitolo: «Dati tecnici motoriduttori» individuare la tabella relativa ad una potenza motore normalizzata  $P_n$  tale che:

$$P_n \geq P_{r1} \quad (6)$$

Se non diversamente indicato, la potenza  $P_n$  dei motori riportata a catalogo si riferisce al servizio continuo S1. Per i motori utilizzati in condizioni diverse da S1, sarà necessario identificare il tipo di servizio previsto con riferimento alle Norme CEI 2-3/IEC 34-1. In particolare, per i servizi da S2 a S8 e per le grandezze motore uguali o inferiori a 132, è possibile ottenere una maggiorazione della potenza rispetto a quella prevista per il servizio continuo, pertanto la condizione da soddisfare sarà:

$$P_n \geq \frac{P_{r1}}{f_m} \quad (7)$$

Il fattore di maggiorazione  $f_m$  è ricavabile dalla tabella che segue.

#### Rapporto di intermittenza

$$I = \frac{t_f}{t_f + t_r} \times 100 \quad (8)$$

$t_f$  =tempo di funzionamento a carico costante

$t_r$  =tempo di riposo

	SERVIZIO						
	S2			S3*			S4 - S8
	Durata del ciclo [min]			Rapporto di intermittenza (I)			
	10	30	60	25%	40%	70%	Interpellare il Servizio Tecnico di Bonfiglioli Riduttori
$f_m$	1.35	1.15	1.05	1.25	1.15	1.1	

\* La durata del ciclo dovrà comunque essere uguale o inferiore a 10 minuti; se superiore interpellare il Servizio Tecnico di Bonfiglioli Riduttori.



Nella sezione relativa alla potenza installata  $P_n$  selezionare infine il motoriduttore che sviluppa la velocità di funzionamento più prossima alla velocità  $n_2$  desiderata e per il quale il fattore di sicurezza  $S$  sia uguale, o superiore, al fattore di servizio  $f_s$ .

$$S \geq f_s \quad (9)$$

Il fattore di sicurezza è così definito:

$$S = \frac{M_{n2}}{M_2} = \frac{P_{n1}}{P_1} \quad (10)$$

Nelle tabelle di selezione motoriduttori gli abbinamenti sono sviluppati con motori a 2, 4 e 6 poli alimentati a 50 Hz.

Per velocità di comando diverse da queste, effettuare la selezione con riferimento ai dati nominali forniti per i riduttori.

## 4.2 Selezione di un riduttore

- Determinare il fattore di servizio  $f_s$ .
- Determinare la coppia di calcolo  $M_{c2}$  dalla relazione:

$$M_{c2} = M_{r2} \times f_s \quad (11)$$

- Ricavare il rapporto di trasmissione:

$$i = \frac{n_1}{n_2} \quad (12)$$

- Nel capitolo: «Dati tecnici riduttori» individuare la grandezza di riduttore il quale, per la velocità di comando  $n_1$  e per il rapporto  $[i]$  più prossimo a quello calcolato, offra una coppia nominale che soddisfi la seguente condizione:

$$M_{n2} \geq M_{c2} \quad (13)$$

Verificare l'applicabilità del motore selezionato al paragrafo: «Predisposizioni motore».



## 5 VERIFICHE

Effettuata la selezione del riduttore, o motoriduttore, è opportuno procedere alle seguenti Verifiche:

### a) Coppia massima

Generalmente la coppia massima (intesa come punta di carico istantaneo) applicabile al riduttore non deve superare il 150% della coppia nominale  $M_{n2}$ ; sono ammessi valori di picco fino al 300% previa valutazione ed approvazione del Servizio Tecnico Bonfiglioli.

Per i motori trifase a doppia polarità è necessario rivolgere particolare attenzione alla coppia di commutazione istantanea che viene generata durante la commutazione dall'alta velocità alla bassa in quanto può essere decisamente più elevata della coppia massima stessa.

Un metodo semplice ed economico per ridurre tale coppia è quello di alimentare solo due fasi del motore durante la commutazione (il tempo di alimentazione a due fasi può essere regolato mediante un relè a tempo):

<b>Coppia di commutazione</b>	
<b><math>Mg_2 = 0.5 \times Mg_3</math></b>	
<b><math>Mg_2</math></b>	Coppia di commutazione alimentando 2 fasi
<b><math>Mg_3</math></b>	Coppia di commutazione alimentando 3 fasi

### b) Carichi radiali

Verificare che i carichi radiali Agenti sugli alberi di entrata e/o uscita rientrino nei valori di catalogo ammessi. Se superiori, aumentare la grandezza del riduttore oppure modificare la supportazione del carico.

Ricordiamo che tutti i valori indicati nel catalogo si riferiscono a carichi agenti sulla mezzzeria della sporgenza dell'albero in esame per cui, in fase di verifica, è indispensabile tenere conto di questa condizione provvedendo, se necessario, a determinare con le apposite formule il carico ammissibile alla distanza  $x$  a cui si applica la risultante del carico radiale.

### c) Carichi assiali

Anche gli eventuali carichi assiali dovranno essere confrontati con i valori ammissibili.

Se si è in presenza di carichi assiali molto elevati o combinati con carichi radiali, si consiglia di interpellare il ns. Servizio Tecnico.

### d) Avviamenti orari

Per servizi diversi da S1, con un numero rilevante di inserzioni/ora si dovrà tener conto di un fattore  $Z$  (determinabile con le indicazioni riportate nel capitolo dei motori) il quale definisce il numero max. di avviamenti specifico per l'applicazione in oggetto.

## 6 INSTALLAZIONE

### 6.1 Specifiche di carattere Generale

a) Assicurarsi che il fissaggio del riduttore sia stabile onde evitare qualsiasi vibrazione.

Se si prevedono urti, sovraccarichi prolungati o possibili bloccaggi installare giunti idraulici, frizioni, limitatori di coppia, ecc.



- b) Prima della eventuale verniciatura proteggere le superfici lavorate e il bordo degli anelli di tenuta per evitare che il solvente venga a contatto con la gomma, pregiudicando l'integrità del paraolio stesso.
- c) Gli organi che vanno calettati sugli alberi di uscita del riduttore devono essere lavorati con tolleranza ISO H7 per evitare accoppiamenti troppo bloccati che, in fase di montaggio potrebbero danneggiare irreparabilmente il riduttore stesso. Inoltre, per il montaggio e lo smontaggio di tali organi si consiglia l'uso di adeguati tiranti ed estrattori utilizzando il foro filettato posto in testa alle estremità degli alberi.
- d) Le superfici di contatto dovranno essere pulite e trattate con adeguati protettivi prima del montaggio, onde evitare l'ossidazione e il conseguente bloccaggio delle parti.
- e) Prima della messa in servizio del riduttore accertarsi che la macchina che lo incorpora sia in regola con le disposizioni della Direttiva Macchine 2006/42/CE, e successivi aggiornamenti.
- f) Prima della messa in funzione della macchina, accertarsi che la posizione del livello del lubrificante sia conforme alla posizione di montaggio del riduttore e che la viscosità sia adeguata.
- g) Nel caso di installazione all'aperto prevedere adeguate protezioni e/o carterature allo scopo di evitare l'esposizione diretta agli agenti atmosferici e alla radiazione solare.

## 6.2 Messa in servizio riduttori serie W

I gruppi W 63, W 75 e W 86 sono forniti di un coperchio laterale orientabile, dotato di un tappo cieco per esigenze di trasporto.

Prima della messa in servizio dell'apparecchiatura questo deve essere sostituito con il tappo di sfiato che è fornito a corredo.

Vedi figura:

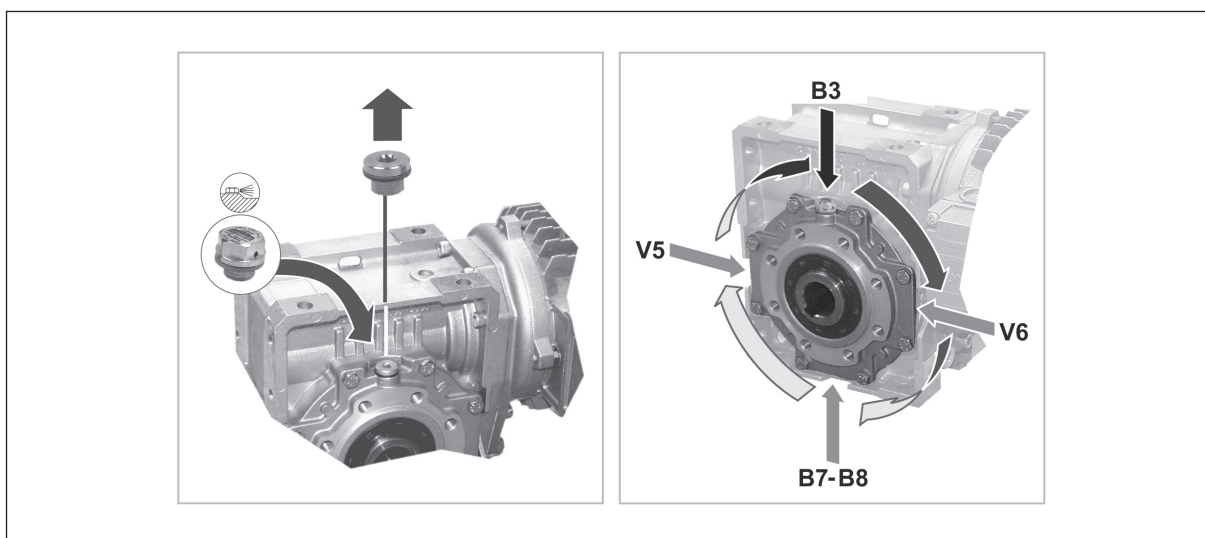

**Nell'orientamento B6 invece il tappo chiuso NON dovrà essere sostituito con il tappo di sfiato.**



## 7 LUBRIFICAZIONE

I riduttori forniti con lubrificazione permanente non necessitano di sostituzioni periodiche dell'olio. Per gli altri si consiglia di consultare il Manuale d'Uso e Manutenzione disponibile al sito [www.bonfiglioli.com](http://www.bonfiglioli.com) per le indicazioni sui controlli periodici del livello dell'olio e sulla sua sostituzione. Evitare di miscelare oli a base minerale con oli sintetici e/o marche differenti. È buona norma comunque controllare il livello una volta al mese per funzionamento intermittente, o più frequentemente, per funzionamento in continuo, e aggiungere olio se necessario.

### 7.1 Scelta della viscosità ottimale dell'olio (dati riferiti ad oli Shell)

Lubrificazione per sbattimento	Olio sintetico (PAG)	Temperatura ambiente di lavoro [C°]																		
		-40	-35	-30	-25	-20	-15	-10	-5	0	+5	+10	+15	+20	+25	+30	+35	+40	+45	+50
		controllo idoneità tenute				con tenute standard fornite a catalogo														
	150 VG	☐	☐	*	*															☎
	220 VG	☐	☐		*	*														☎
	320 VG [1]	☎	☎		*	*														☎
	460 VG [2]					*														☎

☐ Limiti di impiego consigliati.

☎ Limiti di impiego consentiti. ☎

☐ Limiti di impiego non consentiti.

\* = Si suggerisce un avviamento graduale e prevedere un maggior assorbimento del motore. Se necessario e/o nel caso di carichi impulsivi, contattare il Servizio Tecnico Bonfiglioli ☎

[1] Per i riduttori VF - VFR - VF\_EP - W - WR - W\_EP si consiglia la viscosità 320. Per esigenze diverse contattare il Servizio Tecnico Bonfiglioli.

[2] Per i riduttori VFL - WL è obbligatorio l'uso della viscosità 460.

### 7.2 Lubrificazione riduttori W e VF

I gruppi VF 27 ... VF 49, W 63 ... W 86 sono normalmente consegnati con carica di lubrificante del tipo "long life" dalla fabbrica, o dalla rete di vendita ufficiale. Su richiesta gli stessi riduttori possono essere forniti privi di lubrificante, specificando per questi l'opzione **SO**. L'applicabilità dell'opzione è descritta nel capitolo "OPZIONI RIDUTTORE". I gruppi VF 130 ... VF 250 e W 110 sono normalmente forniti privi di lubrificante e sarà cura dell'utilizzatore riempirli di olio prima della messa in servizio. Per questi stessi gruppi è disponibile l'opzione **LUBRIFICAZIONE** che, qualora specificata in fase di ordinativo, garantisce il primo riempimento in fabbrica con differenti tipi di lubrificante sintetico (PAG o ad uso alimentare), in quantità dipendente dalla posizione di montaggio. L'applicabilità dell'opzione è descritta nel capitolo "OPZIONI RIDUTTORE". I riduttori combinati serie VF/VF, VF/W e W/VF sono costituiti da due unità distinte lubrificate autonomamente. Per le tavole di riferimento della collocazione dei tappi di servizio e delle quantità di lubrificante, riferirsi al Manuale Uso e Manutenzione (disponibile su [www.bonfiglioli.com](http://www.bonfiglioli.com)). Il lubrificante "long life" fornito di serie è di natura sintetica (OMALA S4 WE 320) e, a meno di contaminazione dall'esterno, non richiede sostituzioni periodiche per tutto l'arco di vita del riduttore.



## 8 STOCCAGGIO

Il corretto stoccaggio dei prodotti richiede l'esecuzione delle seguenti attività:

- a) Escludere aree all'aperto, zone esposte alle intemperie o con eccessiva umidità.
- b) Interporre sempre tra il pavimento ed i prodotti, pianali lignei o di altra natura, atti ad impedire il diretto contatto col suolo.
- c) Per periodi di stoccaggio e soste prolungate le superfici interessate agli accoppiamenti quali flange, alberi e giunti devono essere protette con idoneo prodotto antiossidante (Mobilarma 248 o equivalente). In questo caso i riduttori dovranno essere posizionati con il tappo di sfiato nella posizione più alta e riempiti interamente d'olio. Prima della loro messa in servizio nei riduttori dovrà essere ripristinata la corretta quantità, e il tipo di lubrificante.

## 9 CONDIZIONI DI FORNITURA

I riduttori vengono forniti come segue:

- a) predisposti per essere installati nella posizione di montaggio come specificato in fase di ordine;
- b) collaudati secondo specifiche Interne;
- c) superfici di accoppiamento non verniciate;
- d) esecuzioni predisposte per l'attacco motore complete di viti e dadi per il fissaggio del motore stesso;
- e) alberi protetti da guaine o cappellotti in plastica per le esigenze del trasporto;
- f) provvisti di golfare di sollevamento (dove previsto).



## RIDUTTORI A VITE SENZA FINE

### 10 CARATTERISTICHE COSTRUTTIVE

#### 10.1 Caratteristiche salienti comuni a tutti i riduttori a vite Bonfiglioli

- Albero lento cavo simmetrico per fissaggio bilaterale del riduttore e degli alberi lenti riportati (disponibili come accessorio).
- Ingranaggi a vite senza fine rettificati e lavorazioni meccaniche di precisione consentono elevati rendimenti e grande silenziosità nel funzionamento.
- Numerose opzioni per il fissaggio del riduttore sfruttando le configurazioni con piedi, con flangia, o pendolare (con braccio di reazione opzionale).
- Estesa possibilità di personalizzazione ricorrendo alla lista delle opzioni disponibili.

#### 10.2 Caratteristiche specifiche dei gruppi tipo VF

- Casse in Alluminio pressofuso per VF27, VF30, VF44 e VF49. Cassa in ghisa per gruppi da VF130 a VF250. Questi ultimi sono verniciati con polveri epossidiche termoindurenti.

#### 10.3 Caratteristiche specifiche dei gruppi tipo W

- Cassa monoblocco in Alluminio, rigida e precisa.
- Grande versatilità e flessibilità nell'applicazione, data dalla forma cubica e dalle numerose superfici lavorate e disponibili per il fissaggio del riduttore, o di organi accessori.
- Configurazione motoriduttore integrale particolarmente compatta, leggera ed economica.
- Anello di tenuta su albero veloce dei gruppi W63, W75 e W86 collocato in posizione interna e con mescola in fluoro-elastomero per migliorate condizioni di funzionamento e durata.

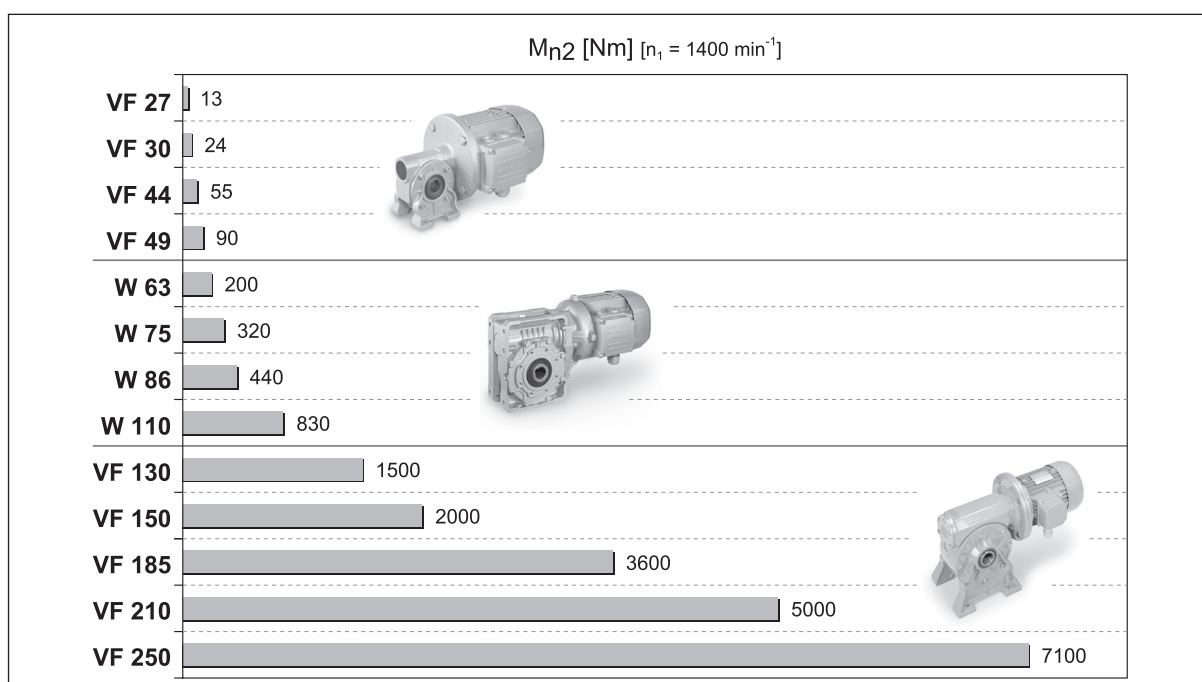



## 11 FORME COSTRUTTIVE

VF_		W_	
	<p><b>N</b> VF 27 ... VF 250</p> <p>Piedi e vite orizzontale in basso</p>		<p><b>U</b> W 63 ... W 110</p> <p>Cassa montaggio universale</p>
	<p><b>A</b> VF 27 ... VF 250</p> <p>Piedi e vite orizzontale in alto</p>		
	<p><b>V</b> VF 27 ... VF 250</p> <p>Piedi e vite verticale</p>		
	<p><b>F</b> VF 27 ... VF 185</p> <p>Flangia standard</p>		<p><b>UF</b> W 63 ... W 110</p> <p>Flangia di montaggio standard</p>
<p><b>F1</b> <b>F2</b></p> <p><b>FA1</b> <b>FA2</b></p>	<p><b>FA</b> VF 44 ... VF 49</p> <p>Flangia alta</p>		
	<p><b>FC</b> VF 130 ... VF 185</p> <p>Flangia corta</p>		
<p><b>FC1</b> <b>FC2</b></p> <p><b>FR1</b> <b>FR2</b></p>	<p><b>FR</b> VF 130 ... VF 185</p> <p>Flangia corta e cuscinetti rinforzati</p>		
	<p><b>P</b> VF 30 ... VF 250</p> <p>Flangia pendolare</p>		<p><b>UFC</b> W 63 ... W 110</p> <p>Flangia di lunghezza ridotta</p>
<p><b>P1</b> <b>P2</b></p> <p>(VF 30...VF 250) (VF 130...VF 185)</p>	<p><b>P1 = P2</b> VF 30 ... VF 49 VF 210, VF 250</p>	<p><b>UFC1</b> <b>UFC2</b></p> <p><b>UFCR1</b> <b>UFCR2</b></p>	<p><b>UFCR</b> W 75</p> <p>Flangia ridotta in lunghezza e diametro</p>
	<p><b>U</b> VF 30 ... VF 49</p> <p>Piedi integrati</p>		

Per i riduttori combinati tipo VF/VF, VF/W e W/VF le forme costruttive si riferiscono al secondo riduttore (lato macchina)



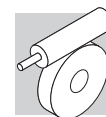

## 12 ESECUZIONE DI MONTAGGIO

Per i riduttori combinati, se non diversamente specificato in fase di ordinativo, verranno configurate le esecuzioni di montaggio evidenziate in grigio nello schema seguente.

	CW1	CCW1	CW2	CCW2	CW3	CCW3	CW4	CCW4
U								
UF_ UFC_ UFR1_								
N								
A								
V								
F1 FA1 FC1 FR1								
F2 FA2 FC2 FR2								
P1								
P2								

Coperchio per fissaggio pendolare



Nella configurazione HS (albero veloce cilindrico) è possibile ottenere tutte le esecuzioni di montaggio raffigurate.

Nella configurazione P (IEC) determinate esecuzioni di montaggio possono essere ottenute solo utilizzando flange IEC (B5 o B14) di grandezza uguale o inferiore a quelle riportate nella tabella seguente.

		CW1 CCW1	CW2 CCW2	CW3	CCW3	CW4 CCW4
VF/VF30/44	A, N, V, P1 F-FA,U	63B14	63B14	63B14	63B14	63B14
VF/VF30/49	A, N, V, P1, F-FA,U	63B14	63B14	63B14	63B14	63B14
VF/W30/63	U, UF-UFC	63B5-63B14	63B5-63B14	63B5-63B14	63B5-63B14	63B5-63B14
VF/W44/75	U, UF-UFC-UFCR	71B5-71B14	71B5-71B14	71B5-71B14	71B5-71B14	71B5-71B14
VF/W44/86	U, UF-UFC	71B5-71B14	71B5-71B14	71B5-71B14	71B5-71B14	71B5-71B14
VF/W49/110	U, UF-UFC	80B5-80B14	80B5-80B14	80B5-80B14	80B5-80B14	80B5-80B14
W/VF63/130	N	71B5-90B14	90B5-90B14	71B5-90B14	71B5-90B14	71B5-90B14
	A	90B5-90B14	71B5-90B14	90B5-90B14	90B5-90B14	90B5-90B14
	V		90B5-90B14			—
	F1	90B5-90B14	71B5-90B14	90B5-90B14	71B5-90B14	90B5-90B14
	FC1-FR1				90B5-90B14	
	P1				90B5-90B14	
	F2	90B5-90B14	71B5-90B14	71B5-90B14	90B5-90B14	90B5-90B14
	FC2-FR2			90B5-90B14		
P2			90B5-90B14			
W/VF86/150	N	112B5-112B14	112B5-112B14	71B5-112B14	71B5-112B14	71B5-112B14
	A	112B5-112B14	90B5-112B14	112B5-112B14	112B5-112B14	112B5-112B14
	V	112B5-90B14	112B5-90B14			71B5-112B14
	F1	112B5-112B14	71B5-90B14	112B5-112B14	71B5-90B14	112B5-112B14
	FC1-FR1		90B5-112B14		112B5-112B14	
	P1		90B5-112B14		112B5-112B14	
	F2	112B5-112B14	71B5-90B14	71B5-90B14	112B5-112B14	112B5-112B14
	FC2-FR2		90B5-112B14	112B5-112B14		
P2			112B5-112B14			
W/VF86/185	N	112B5-112B14	112B5-112B14	90B5-112B14	90B5-112B14	90B5-112B14
	A	90B5-112B14	112B5-112B14	112B5-112B14	112B5-112B14	112B5-112B14
	V	112B5-90B14				90B5-112B14
	F1	112B5-112B14	90B5-112B14	112B5-112B14	90B5-112B14	112B5-112B14
	FC1-FR1				112B5-112B14	
	P1				112B5-112B14	
	F2	112B5-112B14	90B5-112B14	90B5-112B14	112B5-112B14	112B5-112B14
	FC2-FR2			112B5-112B14		
P2			112B5-112B14			
VF/VF130/210	N	#	132B5	#	#	#
	A	132B5	#	132B5	132B5	132B5
	V					
	P					
VF/VF130/250	N	#	132B5	#	#	#
	A	132B5	#	132B5	132B5	132B5
	V		132B5			
	P		#			

# Consultare il ns. servizio Tecnico Commerciale

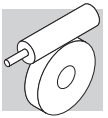

## 12.1 Orientamento morsettiera

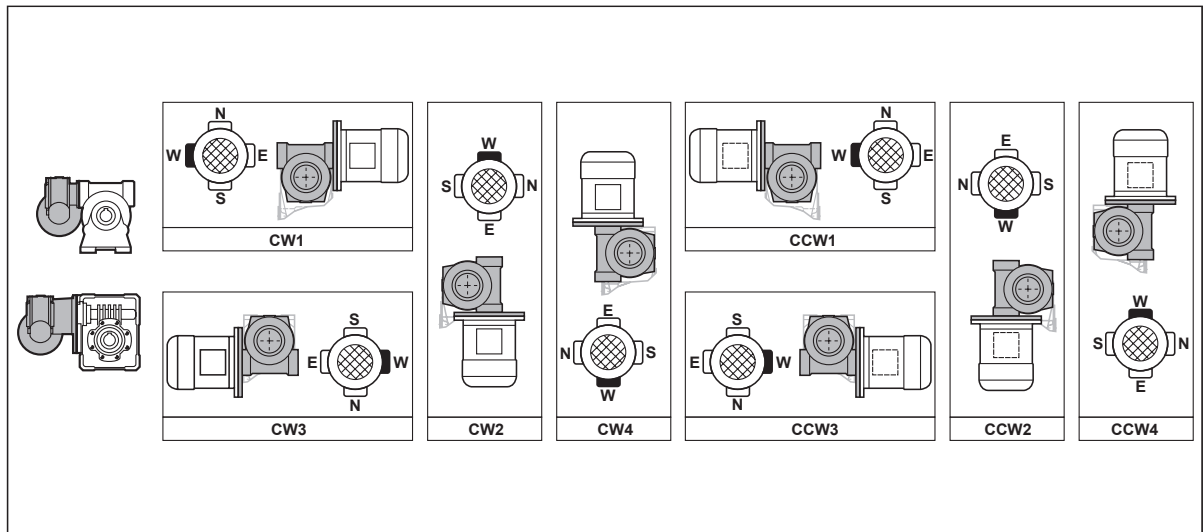



## 13 DESIGNAZIONE

### RIDUTTORE

**W 63 L1 UF1 — 24 S2 — B3** .....

#### OPZIONI

##### ESECUZ. DI MONTAGGIO

VF/VF, VF/W, W/VF	<b>CW (1, 2, 3, 4)</b> <b>CCW (1, 2, 3, 4)</b>
-------------------	---





















##### POSIZIONE DI MONTAGGIO

VF 27...VF 49 VFR 44, VFR 49	<b>B3</b>
W, WR VF 130...VF 250 VFR 130...VFR 250	<b>B3 (default), B6, B7, B8, V5, V6</b>
VF/VF VF/W W/VF	 <b>B3 (default), B6, B7, B8, V5, V6</b>

##### INTERFACCIA MOTORE IEC

<b>B5</b>	(VF 30...VF 250, VFR 49...VFR 250, W, WR)
<b>B14</b>	(VF 30...VF 49, W)

##### DESIGNAZIONE INGRESSO

	VF	VFR	W	WR	VF/VF	VF/W	W/VF
<b>P(IEC)</b>	 P27 (VF 27 only), P56...P225	 P63, P80...P160	 P71...P132	 P63...P112	 P56, P63, P90...P132	 P56...P80	 P71...P112
<b>S_</b>		 S44 (VFR 44 only)	 S1...S3 S10...S30				 S1...S3 S10...S30
<b>HS</b>							

##### RAPPORTO DI RIDUZIONE

##### DIAMETRO ALBERO LENTO

W 75 VF/W 44/75	<b>D30 (default), D28 (Su richiesta)</b>
--------------------	--

##### FORMA COSTRUTTIVA

##### LIMITATORE DI COPPIA

VF, VFR W, WR	<b>L1, L2</b>	VF/VF	<b>LF</b>
------------------	---------------	-------	-----------

##### GRANDEZZA RIDUTTORE

VF	<b>27, 30, 44, 49, 130, 150, 185, 210, 250</b>	VF/VF	<b>30/44, 30/49, 130/210, 130/250</b>
VFR	<b>44, 49, 130, 150, 185, 210, 250</b>	VF/W	<b>30/63, 44/75, 44/86, 49/110</b>
W, WR	<b>63, 75, 86, 110</b>	W/VF	<b>63/130, 86/150, 86/185</b>

##### TIPO RIDUTTORE

<b>VF, W</b>	Riduttore a vite senza fine
<b>VFR, WR</b>	Riduttore con precoppia elicoidale
<b>VF/VF, VF/W, W/VF</b>	Riduttore combinato



MOTORE

FRENO

**BN 63A 4 230/400-50 IP54 CLF ..... W FD 3.5 R SB 220 SA .....**

OPZIONI

ALIMENTAZIONE  
FRENO

TIPO RADDRIZZATORE  
AC/DC  
**NB, SB, NBR, SBR**

LEVA DI SBLOCCO FRENO  
**R, RM**

COPPIA FRENANTE

TIPO FRENO  
**FD** (freno c.c.)  
**FA** (freno c.a.)

POSIZIONE MORSETTIERA  
**W** (default), **N, E, S**

FORMA COSTRUTTIVA  
— (motore integrato)  
**B5, B14** (motore IEC)

CLASSE ISOLAMENTO  
**CL F** standard  
**CL H** option

GRADO DI PROTEZIONE  
**IP55** standard (IP54 - motore autofrenante)

TENSIONE - FREQUENZA

NUMERO DI POLI  
**2, 4, 6, 2/4, 2/6, 2/8, 2/12, 4/6, 4/8**

GRANDEZZA MOTORE  
**1SC ... 3LB** (motore integrato)  
**56A ... 180L** (motore IEC) **BN 27, BN 44** (motori speciali)

TIPO MOTORE

**MX - MXN** = trifase integrato, classe IE3  
**BX - BXN** = trifase IEC, classe IE3

**ME** = trifase integrato, classe IE2  
**BE** = trifase IEC, classe IE2

**M** = trifase integrato, classe IE1  
**BN** = trifase IEC, classe IE1





## 14 OPZIONI RIDUTTORE

### LUBRIFICAZIONE

I riduttori VF 27, VF 30, VF 44, VF 49 e W 63, W 75, W 86 in configurazione standard, sono forniti provvisti di carica di lubrificante. I riduttori VF 130, VF 150, VF 185, VF 210, VF 250 e W 110, in configurazione standard, sono forniti privi di lubrificante.

È possibile comunque, per tutte le taglie di riduttori provviste di carica di lubrificante, richiedere fornitura con ulteriori tipologie di olio, selezionabile in accordo a quanto definito nella tabella (LUB. 01). L'applicabilità dell'opzione LUBRIFICAZIONE è descritta nella tabella (LUB. 02).

(LUB. 01)

LUBRIFICAZIONE	Tipo	Designazione	Produttore
LH	Poliglicole (PAG)	OMALA S4 WE 150	
LS	Poliglicole (PAG)	OMALA S4 WE 220	
LO* [1]	Poliglicole (PAG)	OMALA S4 WE 320	
LK [2]	Poliglicole (PAG)	OMALA S4 WE 460	
LA	Uso alimentare	KLUBERSYNTH UH1 6-150	
LB	Uso alimentare	KLUBERSYNTH UH1 6-220	
LC [1]	Uso alimentare	KLUBERSYNTH UH1 6-320	
LD [2]	Uso alimentare	KLUBERSYNTH UH1 6-460	

\* Se non diversamente specificato, i riduttori VF 27, VF 30, VF 44, VF 49 e W 63, W 75, W 86 forniti con carica di lubrificante "a vita" utilizzano olio OMALA S4 WE 320.

[1] Impiego suggerito per i riduttori tipo VF, VFR, VF\_EP, W, WR, W\_EP.

[2] Impiego obbligatorio per i riduttori tipo VFL, WL.

(LUB. 02)

	LUBRIFICAZIONE					
	Posizione di montaggio					
	B3	B6	B7	B8	V5	V6
W 110 U-UF-UFC	X	X	X	X	⊖	⊖
VF 130 A-N-P-F-FC	X	X	X	X	⊖	⊖
VF 130 V	⊖	X	X	⊖	X	X
VF 130 FR	X	⊖	⊖	X	⊖	⊖
VF 150 A-N-P-F-FC	X	X	X	X	⊖	⊖
VF 150 V	⊖	X	X	⊖	X	X
VF 150 FR	X	⊖	⊖	X	⊖	⊖
VF 185 A-N-P-F-FC	X	X	X	X	⊖	⊖
VF 185 V	⊖	X	X	⊖	X	X
VF 185 FR	X	⊖	⊖	X	⊖	⊖
VF 210 A-N-P	X	⊖	⊖	X	⊖	⊖
VF 210 V	⊖	⊖	⊖	⊖	X	X
VF 250 A-N-P	X	⊖	⊖	X	⊖	⊖
VF 250 V	⊖	⊖	⊖	⊖	X	X

### SO

I riduttori tipo VF 27 ... VF 49, W 63 ... W 86, solitamente riempiti in fabbrica di lubrificante, sono in questo caso forniti privi di olio.



## RB

Albero veloce sporgente sul lato opposto comando (escluso VF 27).

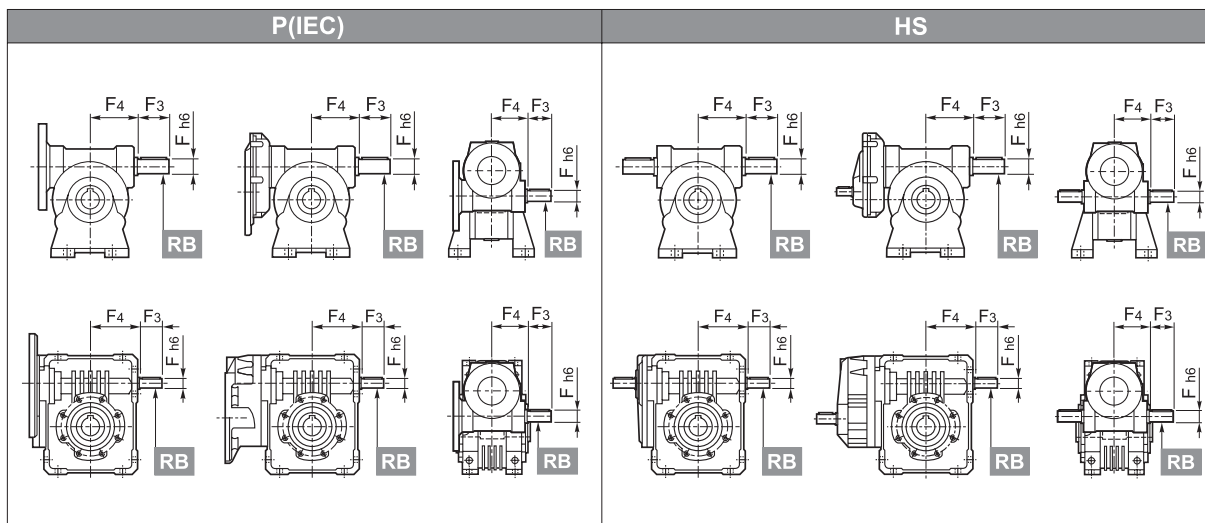

## RBO

Albero veloce sporgente sul 2° riduttore (solo per esecuzioni combinate).

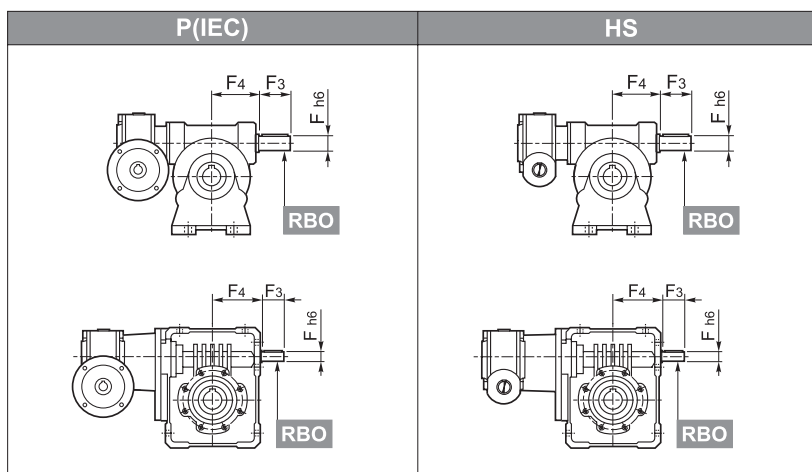

Dimensioni albero sporgente (opzioni RB e RBO)

		F	F1	F2	F3	F4	V	
	<b>VF</b>	<b>30</b>	9	10.2	3	20	—	
	<b>VFR</b>	<b>44</b>	11	12.5	4	30	—	
	<b>VF/VF</b>	<b>49</b>	16	18	5	40	M6	
		<b>63</b>	18	20.5	6	40	M6	
	<b>W</b>	<b>75</b>	19	21.5	6	40	88.5	M6
	<b>WR</b>	<b>86</b>	25	28	8	50	101.5	M8
	<b>VF/W</b>	<b>110</b>	25	28	8	60	127.5	M8
		<b>130</b>	30	33	8	60	160	M8
	<b>VF</b>	<b>150</b>	35	38	10	65	185	M8
	<b>VFR</b>	<b>185</b>	40	43	12	70	214.5	M8
<b>W/VF</b>	<b>210</b>	48	51.5	14	82	185	M16x40	
	<b>250</b>	55	59	16	82	228	M16x40	

Per VF 210 e VF 250, nelle forme costruttive **A** e **P**, normalmente viene montata la ventola di raffreddamento; con l'opzione **RB** non è possibile applicarla.

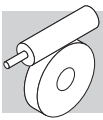

### VV

Anello di tenuta in fluoro-elastomero sull'albero veloce. Disponibile per W110 e per gruppi serie VF, ad esclusione di VF 30 con opzione RB e VF 30\_HS.

### PV

Fornitura di anelli di tenuta in fluoro-elastomero sia sull'albero lento sia sull'albero veloce, ad esclusione di VF 30 con opzione RB, e VF 30\_HS.

### KA

Kit piedi W 63...W 110 per intercambiabilità con gruppi equivalenti VF\_A.

### KV

Kit piedi W 63...W 110 per intercambiabilità con gruppi equivalenti VF\_V (esclusi W con opzione RB e W 110 in posizione di montaggio B6).

### AO

Albero su lato opposto a standard (VF 27).

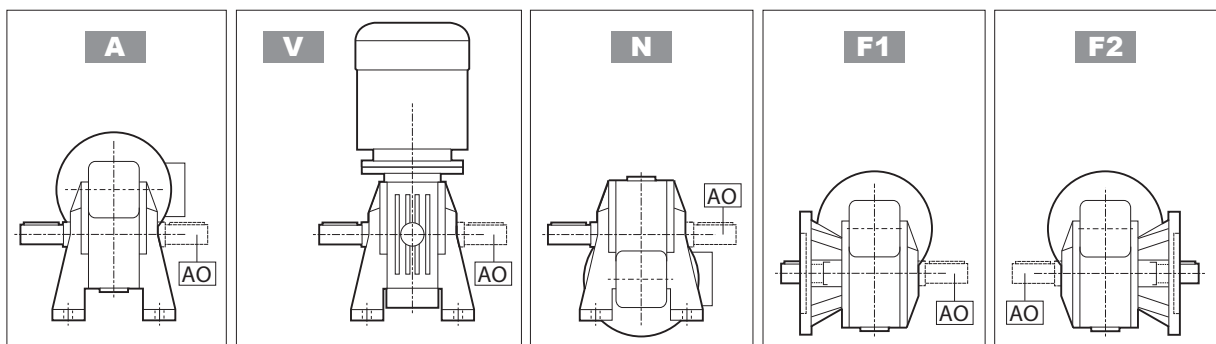

### BP

I riduttori, solitamente forniti con tappo di sfiato aperto, sono forniti con tappo di sfiato a valvola. La taratura della valvola in funzione delle tipologie può variare da 0,10 a 0,15 bar. La valvola si apre ad intervalli e permette l'uscita delle pressioni interne senza permettere l'ingresso di corpi estranei. Per la disponibilità dell'opzione vedere il capitolo "Posizioni di montaggio e tappi di servizio" del Manuale d'Uso e Manutenzione (disponibile su [www.bonfiglioli.com](http://www.bonfiglioli.com)).

Se necessario contattare il Servizio Tecnico Bonfiglioli.

### BRACCIO DI REAZIONE

I riduttori VF 30...VF 250 e W 63... W 110 vengono forniti con il braccio di reazione assemblato. È possibile richiedere il braccio di reazione in diverse posizioni di montaggio (TA1, TA2, TA1B, TA2B, TA1D, TA2D) come illustrato.

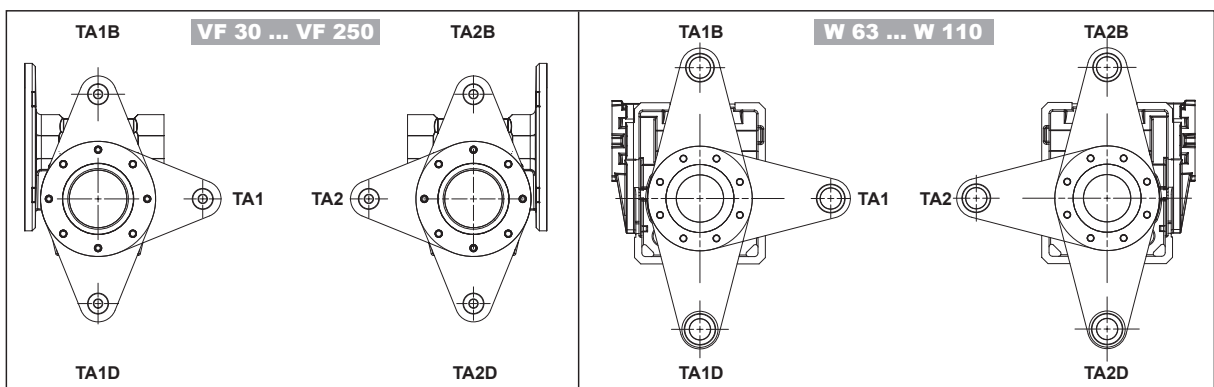





L'applicabilità dell'opzione BRACCIO DI REAZIONE è descritta nella tabella seguente.

		BRACCIO DI REAZIONE	
		TA1 - TA1B - TA1D	TA2 - TA2B - TA2D
VF VFR VF/VF W/VF	VF 30 ... VF 49 F1	⊖	X
	VF 30 ... VF 49 F2	X	⊖
	VF 44 - VF 49 FA1	⊖	X
	VF 44 - VF 49 FA2	X	⊖
	VF 30 ... VF 49 P1	X	X
	VF 210 - VF 250 P1	X	X
	VF 130 ... VF 185 P1	X	⊖
W WR VF/W	VF 130 ... VF 185 P2	⊖	X
	W 63 ... W 110 U	X	X
	W 63 ... W 110 UF1 - UFC1	⊖	X
	W 63 ... W 110 UF2 - UFC2	X	⊖
	W 75 UFCR1	⊖	X
	W 75 UFCR2	X	⊖

L'opzione non è assemblabile nei riduttori VFL-WL nel lato dove è previsto il limitatore di coppia.  
L'opzione non è compatibile con il CAPPELLOTTO DI PROTEZIONE se previsto dallo stesso lato.

### CAPPELLOTTO DI PROTEZIONE

I riduttori W-WR 63-75-86-110 vengono forniti con un cappellotto di protezione dell'asse lento (in materiale plastico).

È possibile indicare il lato su cui prevedere la protezione (SC1, SC2) come illustrato.

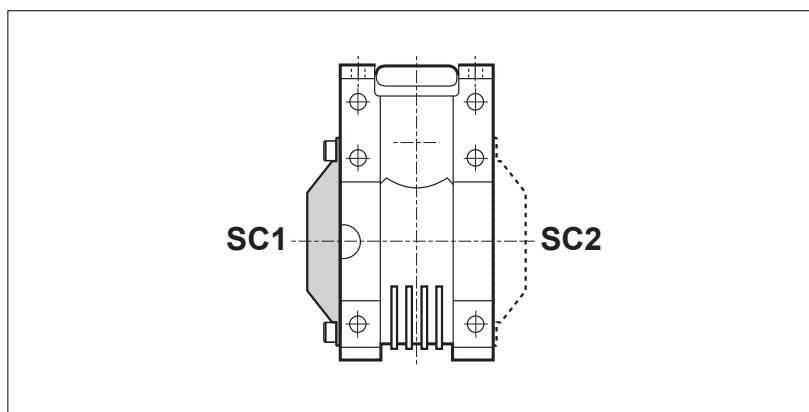

L'applicabilità dell'opzione CAPPELLOTTO DI PROTEZIONE è descritta nella tabella seguente.

		CAPPELLOTTO DI PROTEZIONE	
		SC1	SC2
W WR VF/W	W 63 ... W 110 U	X	X
	W 63 ... W 110 UF1 - UFC1	⊖	X
	W 63 ... W 110 UF2 - UFC2	X	⊖
	W 75 UFCR1	⊖	X
	W 75 UFCR2	X	⊖

L'opzione non è assemblabile nei riduttori VFL-WL nel lato dove è previsto il limitatore di coppia.  
L'opzione non è compatibile con il BRACCIO DI REAZIONE se previsto dallo stesso lato.

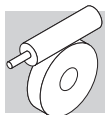

## PROTEZIONE SUPERFICIALE

I riduttori, che laddove non viene richiesta una classe di protezione specifica, nelle zone verniciate (ferrose) rispettano come requisito minimo la classe di protezione C2 (UNI EN ISO 12944-2), sono forniti con protezione superficiale **C3** e **C4** per una migliore resistenza alla corrosione atmosferica, ottenute mediante verniciatura del gruppo completo.

PROTEZIONE SUPERFICIALE	Ambienti tipici	Temperatura superficiale max.	Classe di corrosività secondo UNI EN ISO 12944-2
<b>C3</b>	Ambienti urbani ed industriali, con umidità relativa dell'aria max.100% (inquinamento ambientale medio)	120°C	C3
<b>C4</b>	Aree industriali, zone costiere, impianti chimici, con umidità relativa dell'aria max.100% (inquinamento ambientale alto)	120°C	C4

I riduttori previsti con le protezioni opzionali **C3** e **C4** sono disponibili in diverse tinte.

Se non specificata nessuna tinta (vedere opzione "VERNICIATURA") la fornitura viene eseguita con la tinta RAL7042.

A richiesta sono fornibili riduttori per classe di corrosività **C5** secondo UNI EN ISO 12944-2, contattando il ns. Servizio tecnico-Commerciale.

## VERNICIATURA

I riduttori previsti con le protezioni opzionali C3 e C4 sono disponibili in diverse tinte, secondo la tabella seguente.

VERNICIATURA	Colore	Catalogazione RAL
<b>RAL7042*</b>	Grigio traffico A	7042
<b>RAL5010</b>	Blu genziana	5010
<b>RAL9005</b>	Nero intenso	9005
<b>RAL9006</b>	Alluminio brillante	9006
<b>RAL9010</b>	Bianco puro	9010
<b>RAL7035</b>	Grigio chiaro	7035
<b>RAL7001</b>	Grigio argento	7001
<b>RAL5015</b>	Blu cielo	5015
<b>RAL7037</b>	Grigio polvere	7037
<b>RAL5024</b>	Blu pastello	5024

\* Colore di fornitura standard se non specificato diversamente

NOTA - L'opzione "VERNICIATURA" è configurabile esclusivamente in abbinamento con l'opzione "PROTEZIONE SUPERFICIALE".



## PROVE DOCUMENTALI

### AC - Attestato di conformità

Documento il cui rilascio attesta la conformità del prodotto all'ordinativo e la costruzione dello stesso in conformità alle procedure standard di processo e di controllo previste dal sistema di Qualità Bonfiglioli Riduttori.

### CC - Certificato di collaudo

La specifica comporta la conduzione di verifiche di conformità all'ordine, controlli visivi generali e verifiche strumentali delle dimensioni di accoppiamento. Sono inoltre condotti controlli generali di funzionamento a vuoto e verifiche della funzionalità delle guarnizioni di tenuta in modalità statica e in funzionamento. Il collaudo si applica ad un campione statistico del lotto di spedizione.

### Opzioni motori

Per informazioni sulle opzioni, consultare i relativi capitoli nella sezione Motori Elettrici.

## 15 POSIZIONI DI MONTAGGIO E ORIENTAMENTO MORSETTIERA

Gli orientamenti delle morsettiere dei motori sono identificati osservando il motore dal lato ventola; l'orientamento pre-impostato in fabbrica è evidenziato in nero (W).

**Le posizioni morsettieria illustrate non sono valide per VFR 44. Fare riferimento alla pag. 21 e alle pag. 112-113 per la designazione e l'identificazione della forma costruttiva.**

### Posizione angolare leva di sblocco freno.

Nei motori autofrenanti, la leva di sblocco freno (se richiesta) ha l'orientamento standard a 90° rispetto alla morsettieria (posizione AB); specificare con relative opzioni qualora l'orientamento desiderato sia diverso.

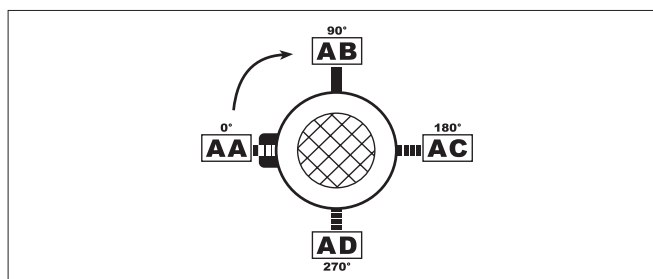

Nelle pagine seguenti sono descritte le posizioni di montaggio dei riduttori tipo VF e W.

Per i riduttori combinati tipo VF/VF, VF/W e W/VF le posizioni di montaggio si riferiscono al secondo riduttore (lato macchina), per il primo riduttore (lato ingresso) fare riferimento al capitolo "Esecuzione di montaggio".



VF 27 \_ ... VF 49 \_

VFR 44 \_ , VFR 49 \_

\_HS

\_S - \_P (IEC)

	_HS			_S - _P (IEC)		
A	B3	B7	V5			 VF
	B6	B8	V6			 VFR*
N	B3	B7	V5			 VF
	B6	B8	V6			 VFR*
V	B3	B7	V5	 VF	 VF	 VFR*
	B6	B8	V6	 VFR	 VF	 VFR*
P	B3	B7	V5			 VF
	B6	B8	V6			 VFR*
F	B3	B7	V5			 VF
	B6	B8	V6			 VFR*
U	B3	B7	V5			 VF
	B6	B8	V6			 VFR*

Posizione di montaggio base.

I riduttori sono targati esclusivamente nella posizione di montaggio base (B3) ma possono essere installati anche nelle posizioni derivate (B6, B7, B8, V5, V6). Dopo l'installazione la posizione di montaggio non può essere variata.

\* Le posizioni morsetti illustrate non sono valide per VFR 44. Fare riferimento alla pag. 21 e alle pag. 126-127 per la designazione e l'identificazione della forma costruttiva.

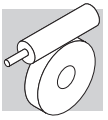

# W 63 U ... W 110 U

# WR 63 U ... WR 110 U

**\_HS**

**\_S - \_P (IEC)**

**B3**

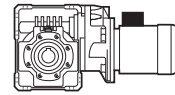
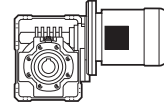
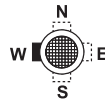
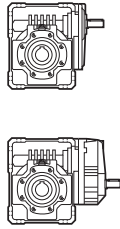
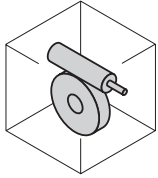

**B6**

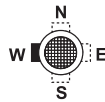
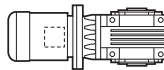
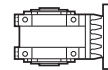
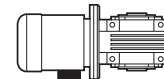
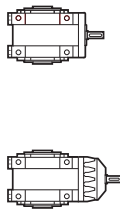
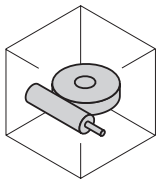

**B7**

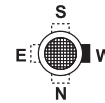
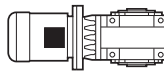
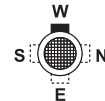
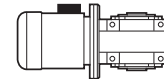
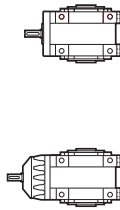
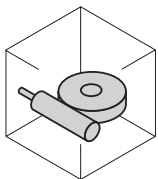

**B8**

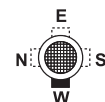
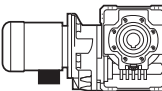
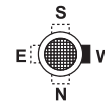
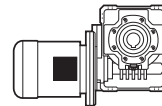
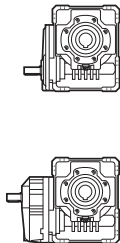
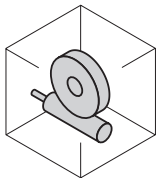

**V5**

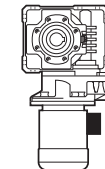
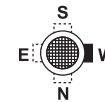
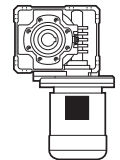
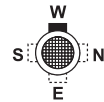
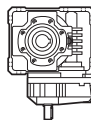
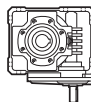
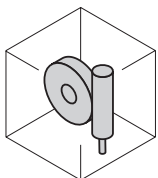

**V6**

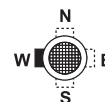
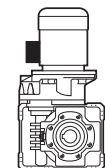
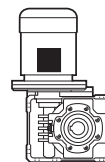
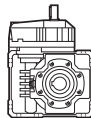
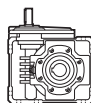
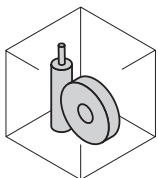



**W 63 UF/UFC ... W 110 UF/UFC    WR 63 UF/UFC ... WR 110 UF/UFC**

**\_HS**

**\_S - \_P (IEC)**

**B3**

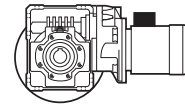
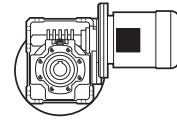
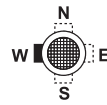
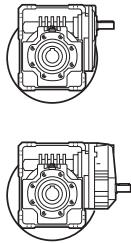
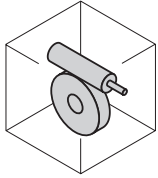

**B6**

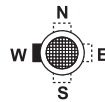
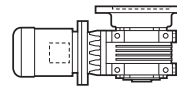
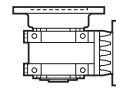
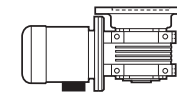
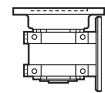
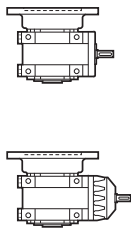
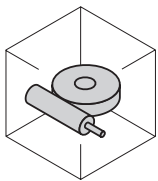

**B7**

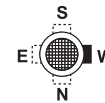
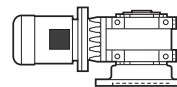
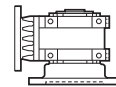
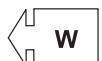
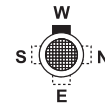
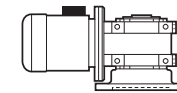
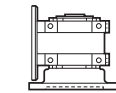
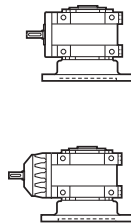
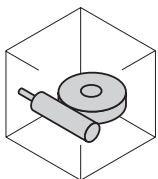

**B8**

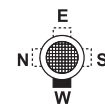
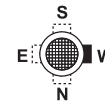
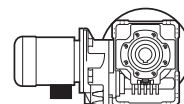
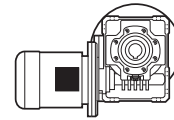
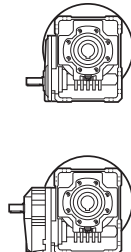
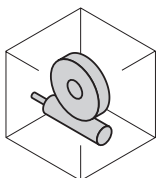

**V5**

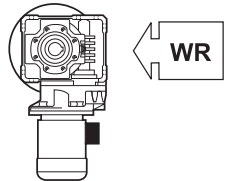
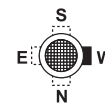
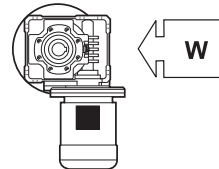
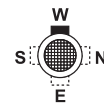
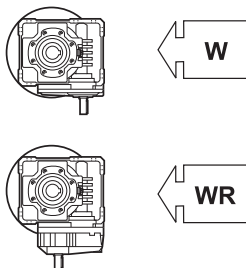
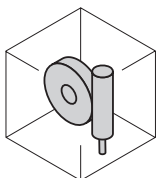

**V6**

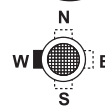
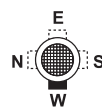
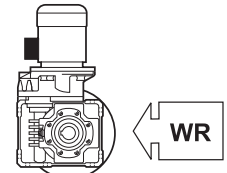
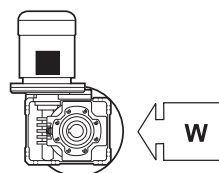
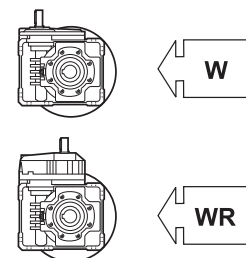
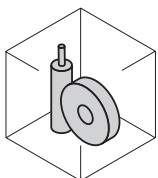

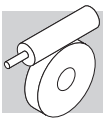

**VF 130 A ... VF 250 A      VFR 130 A ... VFR 250 A**

	<b>_HS</b>	<b>_P (IEC)</b>	
<b>B3</b>			
			<b>VF</b>
			<b>VFR</b>
<b>B6</b>			
			<b>VF</b>
			<b>VFR</b>
<b>B7</b>			
			<b>VF</b>
			<b>VFR</b>
<b>B8</b>			
			<b>VF</b>
			<b>VFR</b>
<b>V5</b>			
			<b>VF</b>
			<b>VFR</b>
<b>V6</b>			
			<b>VF</b>
			<b>VFR</b>



# VF 130 N ... VF 250 N

# VFR 130 N ... VFR 250 N

**\_HS**

**\_P (IEC)**

**B3**

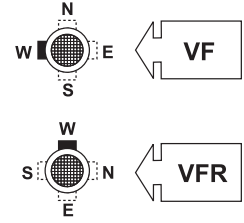
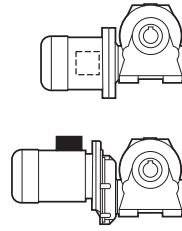
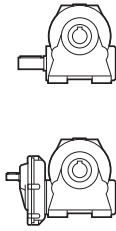
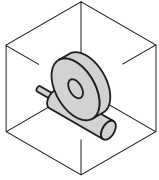

**B6**

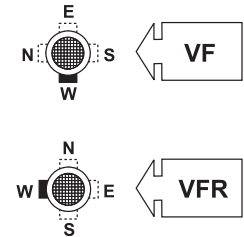
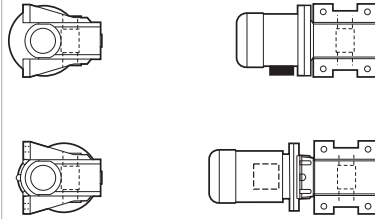
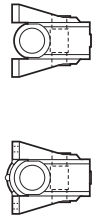
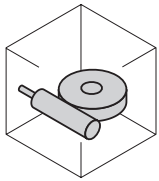

**B7**

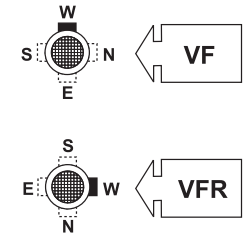
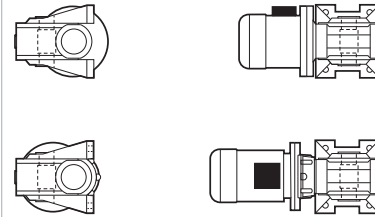
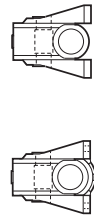
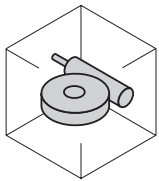

**B8**

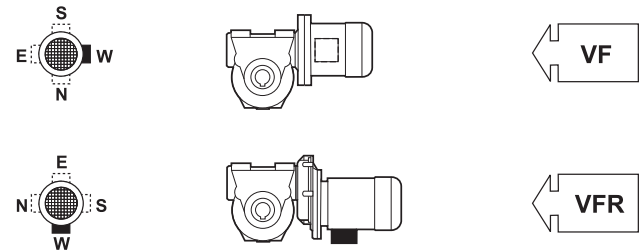
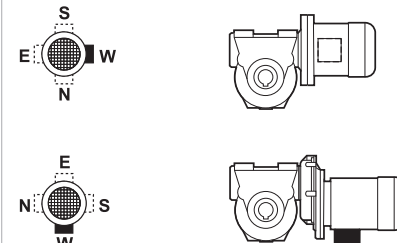
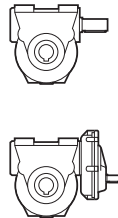
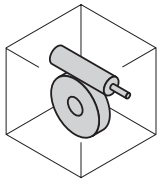

**V5**

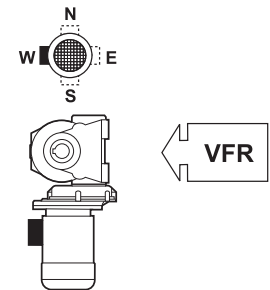
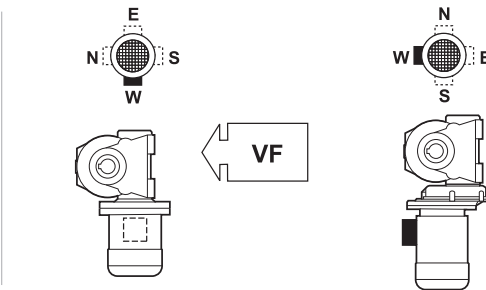
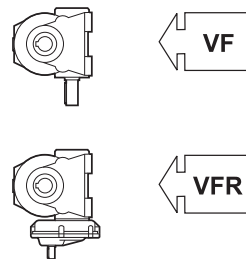
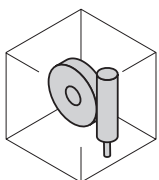



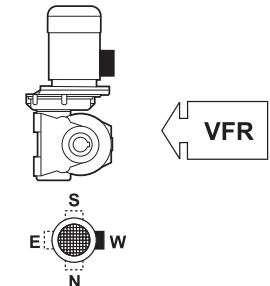
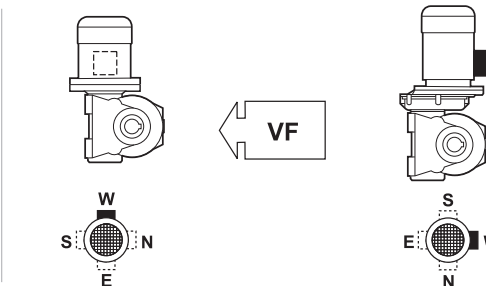
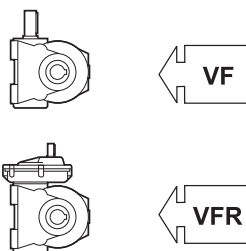
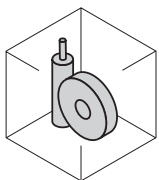



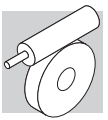



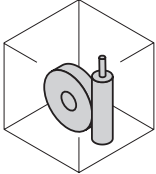
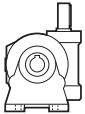

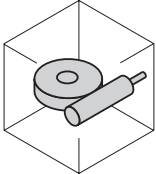
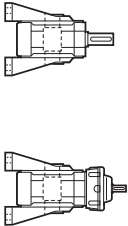
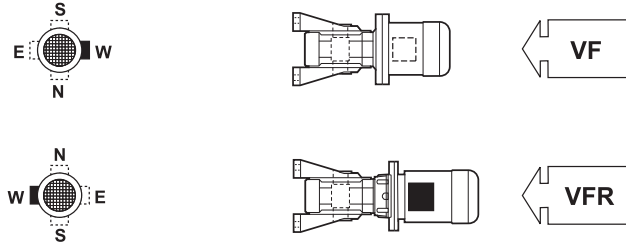
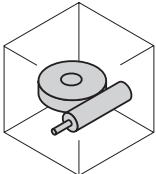
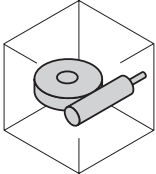
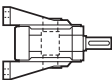
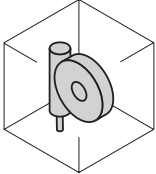
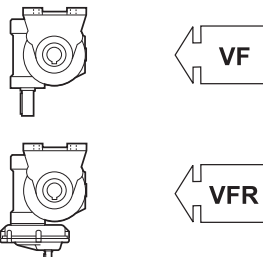
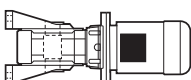
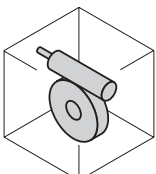
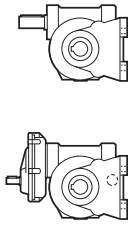
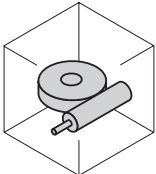
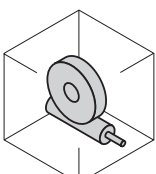
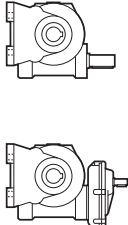
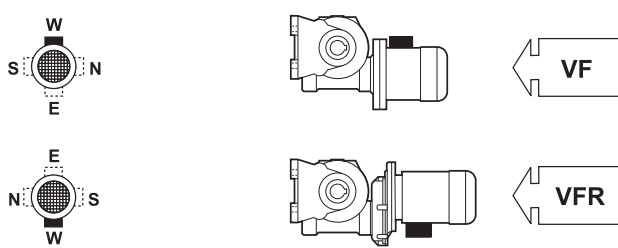
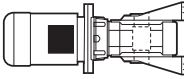

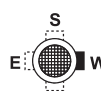
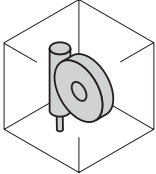



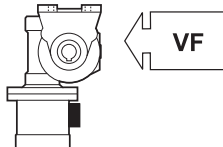

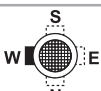
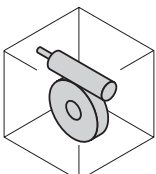

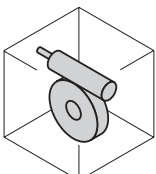
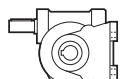
**V6**

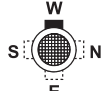

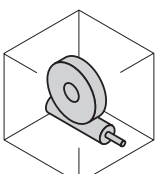
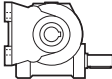



# VF 130 V ... VF 250 V      VFR 130 V ... VFR 250 V

	_HS	_P (IEC)
<b>B3</b>	  ← VF  ← VFR	 ← VF  ← VFR  N, S, E, W  S, N, E, W
<b>B6</b>	  	 ← VF  ← VFR  S, N, E, W  N, S, E, W
<b>B7</b>	  	 ← VF  ← VFR  N, S, E, W  S, N, E, W
<b>B8</b>	  ← VF  ← VFR	 ← VF  ← VF  ← VFR  ← VFR  N, S, E, W  S, N, E, W
<b>V5</b>	  	 ← VF  ← VFR  E, S, N, W  W, S, N, E
<b>V6</b>	  	 ← VF  ← VF  ← VFR  W, S, N, E  E, N, S, W

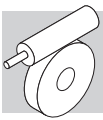

# VF 130 P ... VF 250 P

# VFR 130 P ... VFR 250 P

**\_HS**

**\_P (IEC)**

**B3**

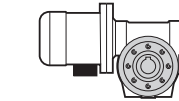
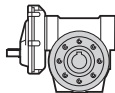
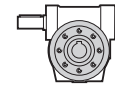
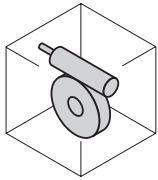

**B6**

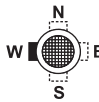
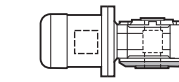
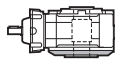
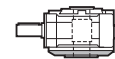
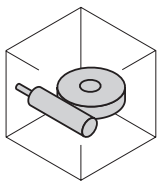

**B7**

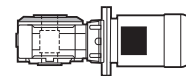
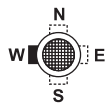
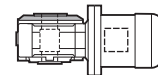
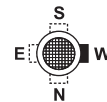
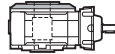
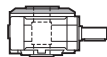
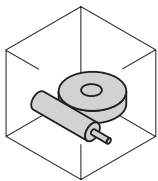

**B8**

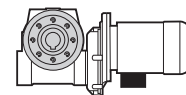
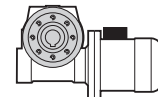
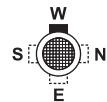
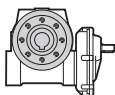
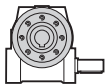
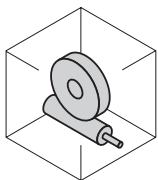

**V5**

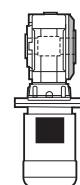
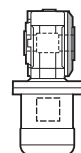
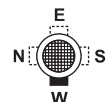
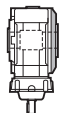
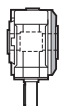
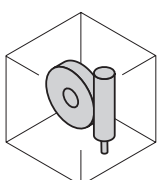

**V6**

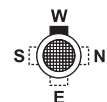
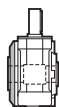
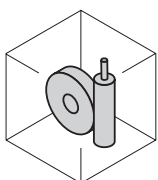



# VF 130 F ... VF 250 F      VFR 130 F ... VFR 250 F

**\_HS**

**\_P (IEC)**

**B3**

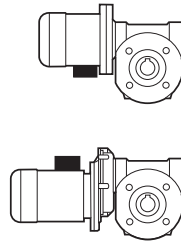
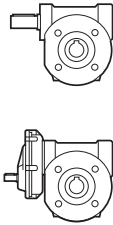
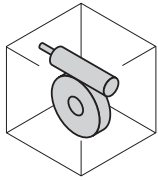

**B6**

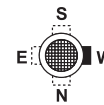
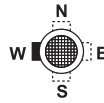
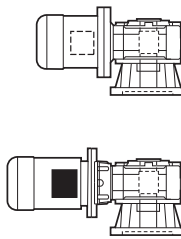
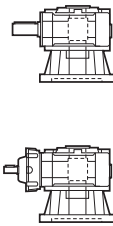
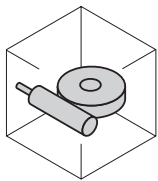

**B7**

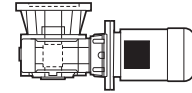
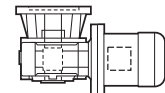
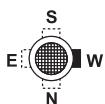
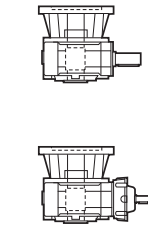
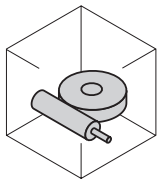

**B8**

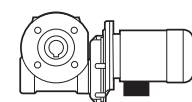
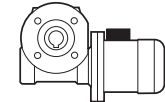
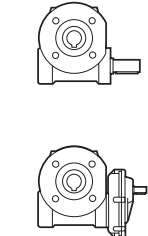
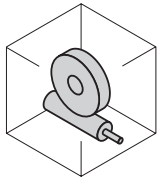

**V5**

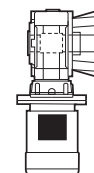
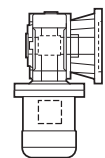
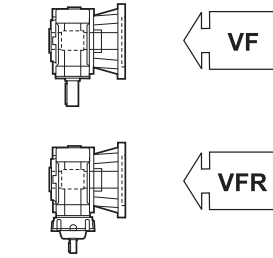
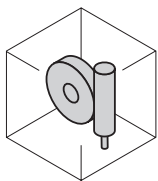

**V6**

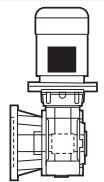
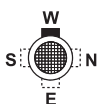
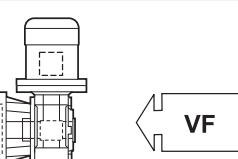
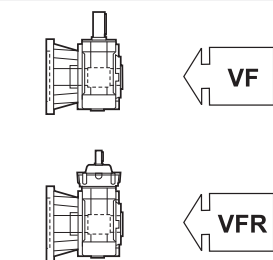
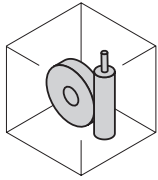

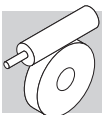

## 16 CARICHI RADIALI

### 16.1 Forza risultante sull'albero

Organi di trasmissione calettati sugli alberi di ingresso e/o di uscita del riduttore generano forze la cui risultante agisce in senso radiale sull'albero stesso.

L'entità di questi carichi deve essere compatibile con la capacità di sopportazione del sistema albero-cuscinetti del riduttore, in particolare il valore assoluto del carico applicato ( $R_{c1}$  per albero di ingresso,  $R_{c2}$  per albero di uscita) deve essere inferiore al valore nominale ( $R_{n1}$  per albero di ingresso,  $R_{n2}$  per albero di uscita) riportato nelle tabelle dati tecnici.

Il procedimento sotto descritto si applica indifferentemente all'albero veloce o all'albero lento avendo l'avvertenza di utilizzare le costanti relative all'albero interessato dal calcolo.

Il carico generato da una trasmissione esterna può essere calcolato, con buona approssimazione, tramite la formula seguente:

$$R_c = \frac{2000 \times M \times K_r}{d}$$

$K_r = 1$		$M$ [Nm]	
$K_r = 1.25$		$d$ [mm]	
$K_r = 1.5 - 2.0$			

### 16.2 Verifica sopportazione radiale

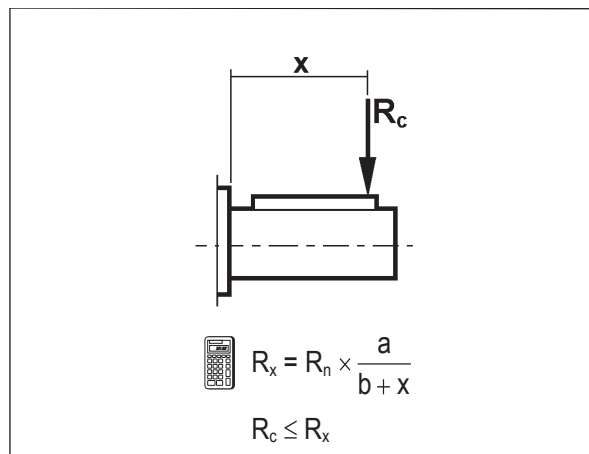
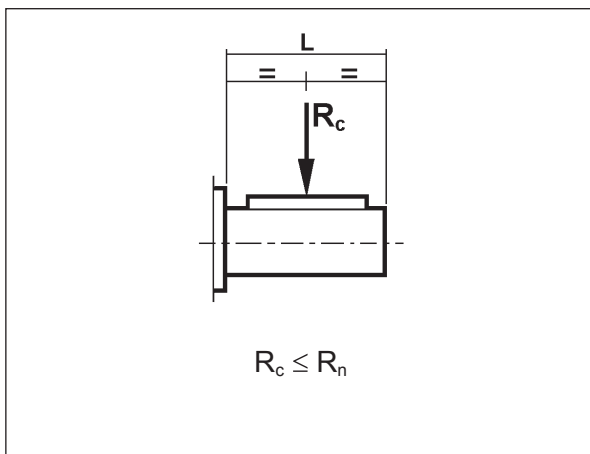



### 16.3 Costanti del riduttore

	Albero lento		$R_{n2} \text{ max}$ [N]
	a	b	
VF 27	56	44	600
VF 30	60	45	1700
VF 44 - VFR 44 - VF/VF 30/44	71	51	2500
VF 49 - VFR 49 - VF/VF 30/49	99	69	3450
W 63 - WR 63 - VF/W 30/63	132	102	5000
W 75 - WR 75 - VF/W 44/75	139	109	6200
W 86 - WR 86 - VF/W 44/86	149	119	7000
W 110 - WR 110 - VF/W 49/110	173	136	8000
VF 130 - VFR 130 - W/VF 63/130	182	142	13800
VF 150 - VFR 150 - W/VF 86/150	198	155	16000
VF 185 - VFR 185 - W/VF 86/185	220	170	19500
VF 210 - VFR 210 - W/VF 130/210	268	203	34500
VF 250 - VFR 250 - W/VF 130/250	334	252	52000

## 17 CARICHI ASSIALI

I valori di carico assiale ammissibile sugli alberi veloce  $[A_{n1}]$  e lento  $[A_{n2}]$  si possono ricavare con riferimento al corrispondente valore di carico radiale  $[R_{n1}]$  e  $[R_{n2}]$  tramite le espressioni che seguono:

$$\begin{aligned} A_{n1} &= R_{n1} \times 0,2 \\ A_{n2} &= R_{n2} \times 0,2 \end{aligned} \quad (14)$$

I valori di carico assiale ammissibile così calcolati si riferiscono al caso di forze assiali agenti contemporaneamente ai carichi radiali nominali.

Nel solo caso in cui il valore del carico radiale agente sull'albero del riduttore sia nullo, si può considerare il carico assiale ammissibile  $[A_n]$  pari al 50% del valore di carico radiale ammissibile  $[R_n]$  sullo stesso albero.

In presenza di carichi assiali eccedenti il valore ammissibile, o di forze assiali fortemente prevalenti sui carichi radiali, è consigliabile contattare il Servizio Tecnico di Bonfiglioli Riduttori per una verifica puntuale.

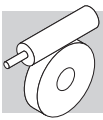

### 17.1 Carichi assiali massimi ammissibili nella forma costruttiva FR

Per soddisfare le applicazioni che richiedono dei carichi assiali molto elevati, è disponibile la forma costruttiva FR prevista nelle grandezze VF 130, VF 150 e VF 185. Questa forma costruttiva, le cui dimensioni esterne sono identiche a quelle della forma FC, può sopportare i carichi assiali (notevolmente superiori a quelli ammessi dalle forme standard) riportati nella tabella seguente riferiti al rapporto di trasmissione [i] ed al senso di rotazione +/- dell'albero lento.

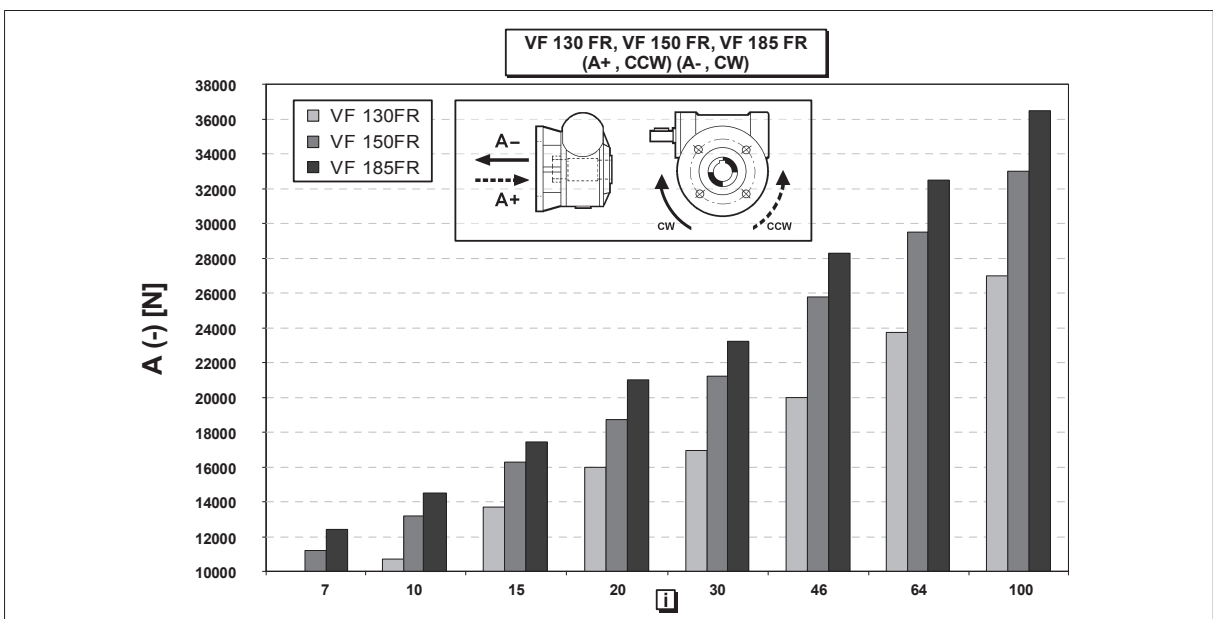
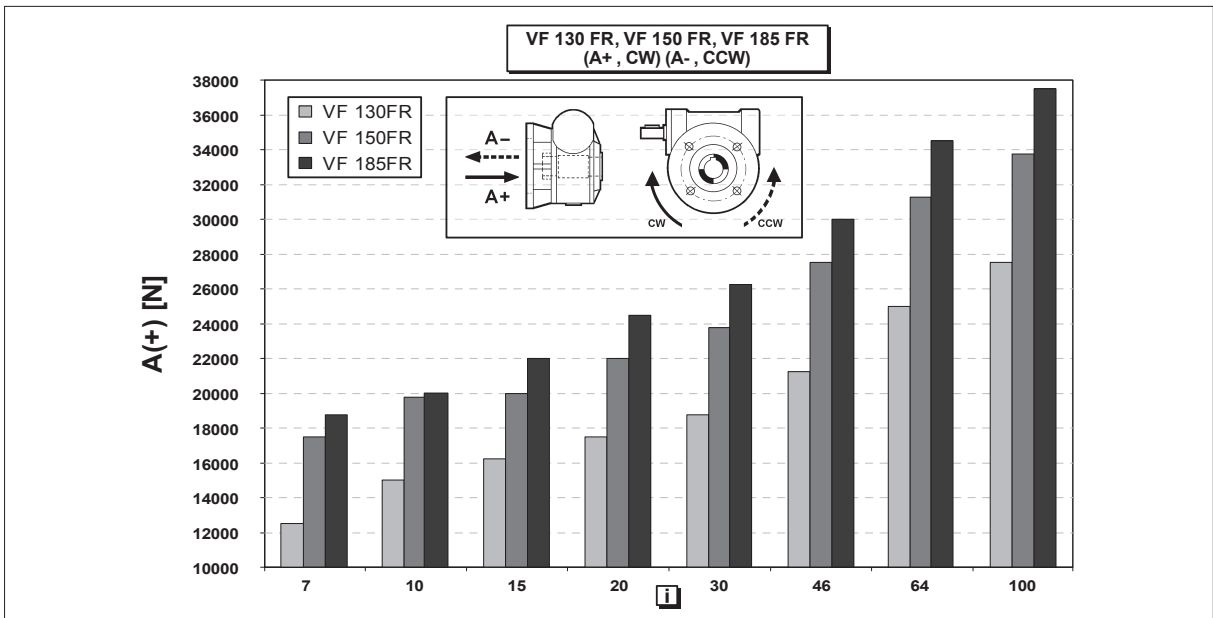
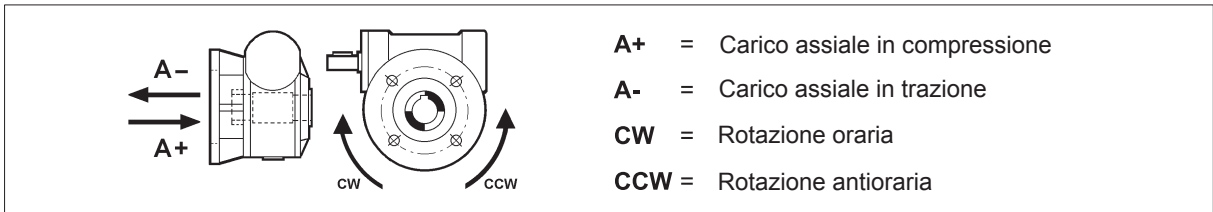

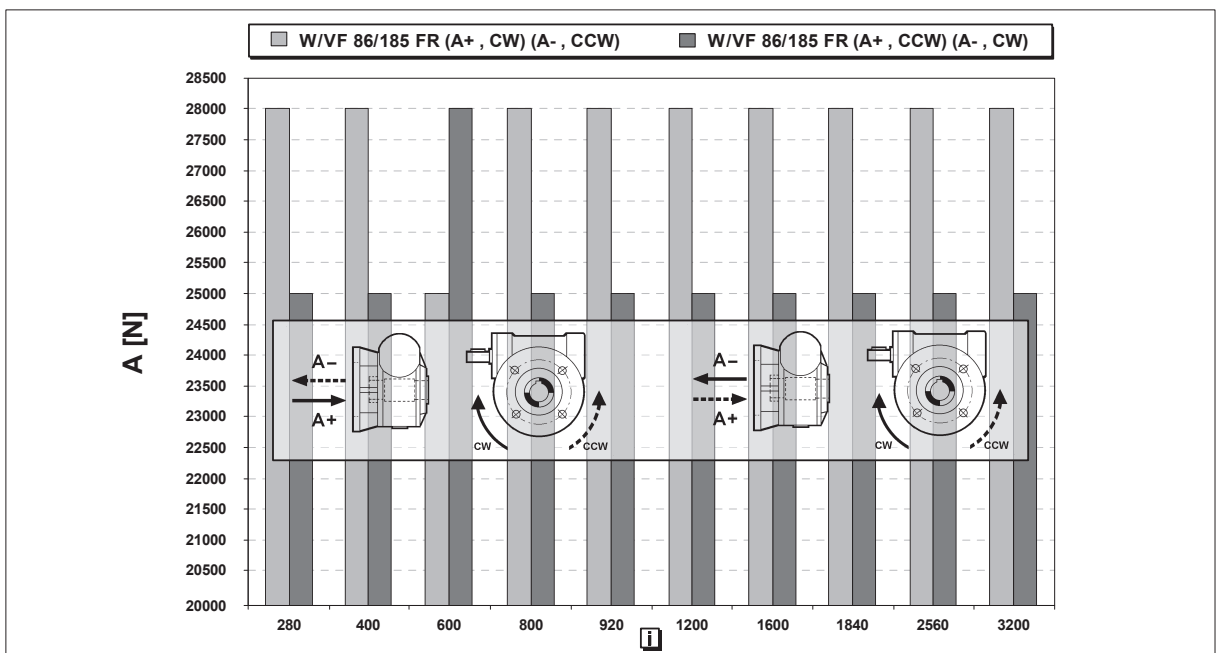
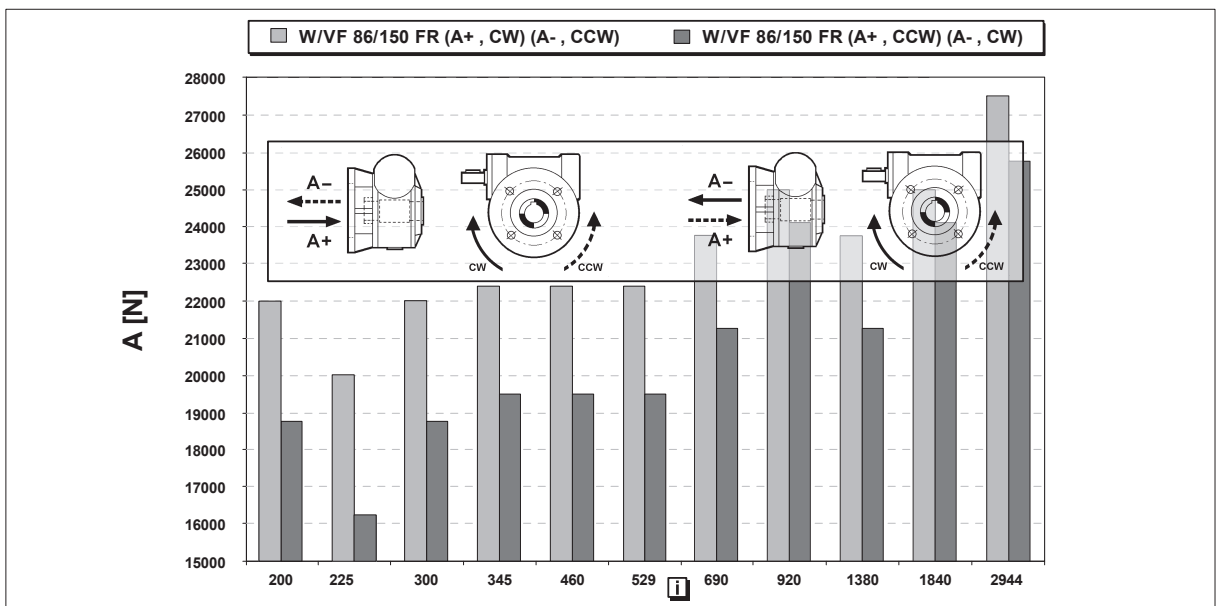
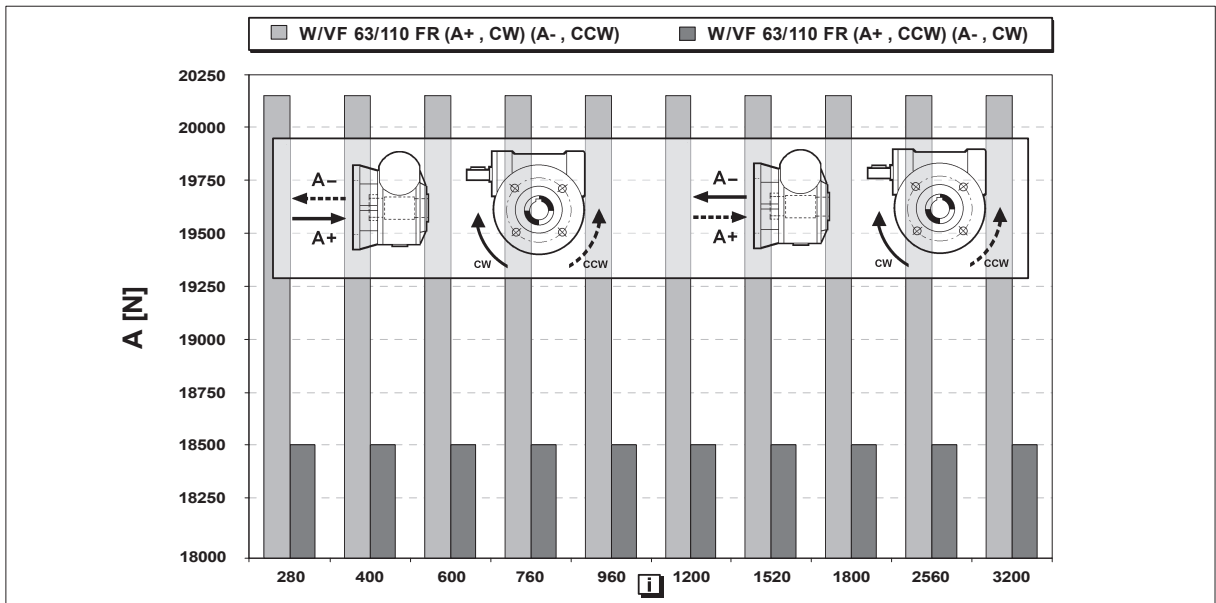



## 18 RENDIMENTO

Il rendimento  $[\eta]$  dipende dai seguenti parametri:

- angolo d'elica dell'ingranaggio
- velocità di comando
- rodaggio dell'ingranaggio

A tale proposito è utile ricordare che il valore ottimale si manifesta dopo alcune ore di rodaggio e viene raggiunto successivamente nei riduttori funzionanti a regime come illustrato nella tabella sotto riportata, per cui in determinate applicazioni dove è previsto un servizio intermittente (sollevamenti, azionamenti, ecc.) è necessario incrementare adeguatamente la potenza del motore al fine di compensare il basso rendimento che si ha nel riduttore all'avviamento.

I valori di coppia nominale  $M_{n2}$  riportati a catalogo sono riferiti al funzionamento a regime, dopo rodaggio. La tabella riporta, a titolo indicativo, il tempo necessario per raggiungere il massimo valore di rendimento dinamico.

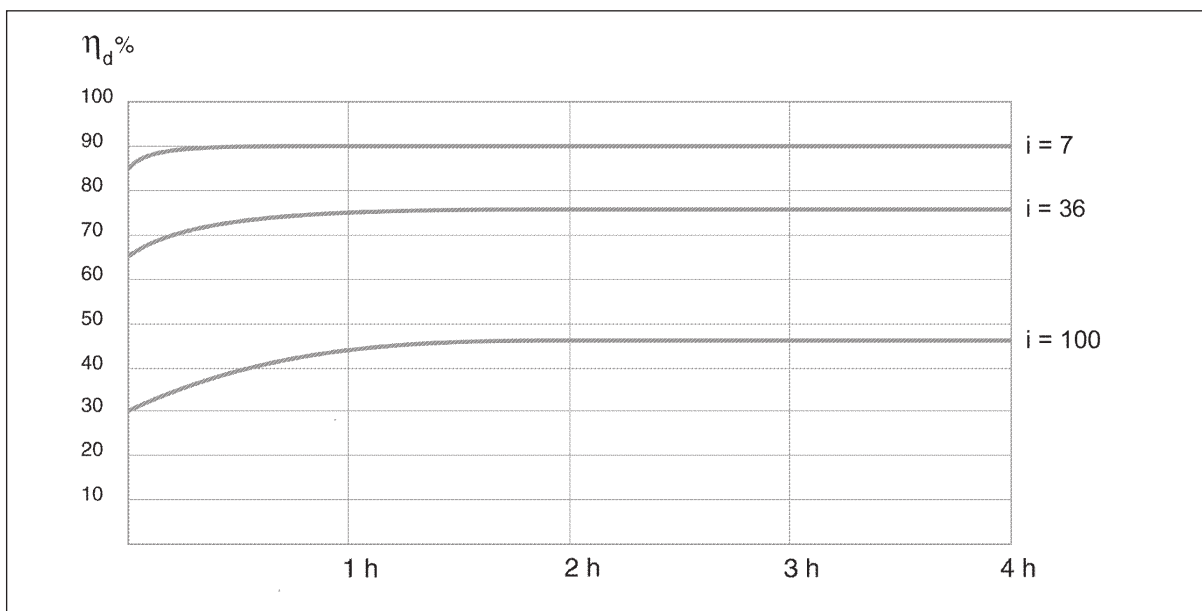

## 19 IRREVERSIBILITÀ

Alcune applicazioni possono comportare occasionalmente la trasmissione del moto retrogrado tramite l'albero lento, mentre altre impongono che il carico sia trattenuto in posizione dal motoriduttore, anche in assenza di alimentazione elettrica.

Alcuni gruppi a vite senza fine offrono la caratteristica di essere irreversibili e il parametro che ne influenza maggiormente questa prestazione è il rendimento.

In particolare il rendimento statico  $\eta_s$  è responsabile della irreversibilità statica (passaggio attraverso una posizione di sosta), mentre il rendimento dinamico  $\eta_d$  è responsabile della eventuale irreversibilità dinamica (moto continuato nella stessa direzione).

L'irreversibilità può esprimersi in misura diversa con i rapporti più lunghi ( $i=64$  e superiori) ad offrire una irreversibilità sempre maggiore.





## 19.1 Irreversibilità statica

Con questa condizione non si può avere la trasmissione del moto con comando dall'asse lento senza escludere però dei ritorni lenti nel caso in cui il gruppo sia sottoposto a vibrazioni. La condizione teorica perchè si verifichi la irreversibilità statica è la seguente:

$$\eta_s < 0.4 - 0.5 \quad (15)$$

dove  $\eta_s$  rappresenta il rendimento statico (valore riportato nelle tabelle dei dati tecnici dei riduttori). Ovviamente, per soddisfare la condizione inversa, cioè la reversibilità statica, si dovrà verificare che:

$$\eta_s > 0.5 \quad (16)$$

## 19.2 Irreversibilità dinamica

La condizione è influenzata direttamente dalla velocità di rotazione, dal rendimento e dalle vibrazioni continue del carico. È caratterizzata da un arresto quasi istantaneo della rotazione quando sull'asse della vite non ci sono più condizioni di moto. Essa è sottoposta alla condizione teorica:

$$\eta_d < 0.5 \quad (17)$$

dove  $\eta_d$  rappresenta il rendimento dinamico del riduttore nelle condizioni di esercizio (valore riportato nelle tabelle dei dati tecnici).

La condizione inversa, cioè di reversibilità dinamica, è fisicamente possibile quando:

$$\eta_d > 0.5 \quad (18)$$

La tabella di seguito propone indicativamente i vari gradi di reversibilità in funzione del tipo di riduttore e del rapporto di riduzione (dati riferiti solo alla coppia vite-corona).

Ovviamente questi dati sono indicativi in quanto si può avere una irreversibilità più o meno accentuata a causa dell'influenza dei fattori citati precedentemente.



**Essendo praticamente impossibile realizzare e garantire una irreversibilità totale è necessario, dove esiste questa esigenza, prevedere un freno esterno sufficiente ad impedire l'avviamento per effetto delle vibrazioni.**



		Grado di reversibilità												
		VF				W				VF				
Reversibilità statica	Reversibilità dinamica	27	30	44	49	63	75	86	110	130	150	185	210	250
<b>si</b>	<b>si</b>	—	—	7	7	7	7	7	7	7	7	7	7	7
<b>si</b>	<b>si</b>	7 10	7 10	10 14	10 14	10 12 15	10 15	10 15 20 23	10 15 20 23	10 15 20 23	10 15 20 23	10 15 20 23	10 15 20 23	10 15 20 23
<b>incerta</b>	<b>si</b>	15 20 30	15 20 30	20 28 35	18 24 28 36	19 24 30 38	20 25 30 40	30 40 46 56	30 40 46 56	30 40 46 56 64	30 40 46 56 64	30 40 50 60	30 40 50 60	30 40 50 60
<b>no</b>	<b>bassa</b>	40 60	40 60	46 60 70	45 60 70	45 64 80	50 60 80	64 80 100	64 80 100	80 100	80 100	80 100	60 80 100	80 100
<b>no</b>	<b>no</b>	70	70	100	80 100	100	100	—	—	—	—	—	—	—

## 20 GIOCHI ANGOLARI

La tabella seguente riporta i valori indicativi del gioco angolare riferito all'albero lento, con albero veloce quindi bloccato.

La misura avviene con l'applicazione di una coppia di 5 Nm all'albero lento.

Giochi angolari (albero veloce bloccato)		
	$\Delta\gamma$ [']	$\Delta\gamma$ [rad]
<b>VF 30</b>	33' ± 10'	0.00873 ± 0.00291
<b>VF 44</b>	25' ± 7'	0.00728 ± 0.00145
<b>VFR 44</b>	30' ± 10'	0.00873 ± 0.00291
<b>VF 49</b>	22' ± 7'	0.00728 ± 0.00145
<b>VFR 49</b>	30' ± 10'	0.00873 ± 0.00291
<b>W 63</b>	20' ± 4'	0.00582 ± 0.00145
<b>WR 63</b>	25' ± 5'	0.00728 ± 0.00145
<b>W 75</b>	18' ± 4'	0.00582 ± 0.00145
<b>WR 75</b>	22' ± 5'	0.00640 ± 0.00145
<b>W 86</b>	15' ± 4'	0.00436 ± 0.00145
<b>WR 86</b>	20' ± 5'	0.00582 ± 0.00145
<b>W 110</b>	9' ± 2'	0.00436 ± 0.00145
<b>WR 110</b>	18' ± 5'	0.00524 ± 0.00145
<b>VF 130</b>	12' ± 3'	0.00349 ± 0.00087
<b>VFR 130</b>	15' ± 3'	0.00436 ± 0.00087
<b>VF 150</b>	12' ± 3'	0.00349 ± 0.00087
<b>VFR 150</b>	15' ± 3'	0.00436 ± 0.00087
<b>VF 185</b>	10' ± 3'	0.00291 ± 0.00087
<b>VFR 185</b>	13' ± 3'	0.00378 ± 0.00087
<b>VF 210</b>	Interpellarci	
<b>VFR 210</b>		
<b>VF 250</b>		
<b>VFR 250</b>		







## 21 DATI TECNICI MOTORIDUTTORI





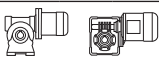

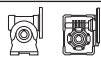
La selezione dei motori senza freno tiene conto delle prescrizioni del Regolamento CE 640/2009 (si veda sezione **M** di questo catalogo). Per potenze nominali inferiori a 0.75kW, possono essere previsti i motori BN/M.

Il Regolamento CE 640/2009 non si applica ai motori autofrenanti, pertanto la selezione dei motori autofrenanti tiene conto dei motori BN/M, a prescindere dal valore della potenza nominale. I motori BX, BE, MX e ME autofrenanti sono disponibili a richiesta.

### 0.04 kW

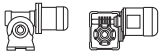
$n_2$ min <sup>-1</sup>	$M_2$ Nm	S	i	$R_{n2}$ N	 IE1		 IEC 			
19.3	9	1.0	70	600			VF 27_70	P27	BN27A4	121
22.5	8	1.1	60	600			VF 27_60	P27	BN27A4	121
34	6	1.4	40	600			VF 27_40	P27	BN27A4	121
45	5	1.7	30	600			VF 27_30	P27	BN27A4	121
68	4	2.2	20	600			VF 27_20	P27	BN27A4	121
90	3	2.8	15	600			VF 27_15	P27	BN27A4	121
135	2	3.8	10	600			VF 27_10	P27	BN27A4	121
193	2	5.5	7	600			VF 27_7	P27	BN27A4	121

### 0.06 kW

$n_2$ min <sup>-1</sup>	$M_2$ Nm	S	i	$R_{n2}$ N	 IE1		 IEC 			
0.59	203	1.0	2280	5000			VF/W 30/63_2280	P56	BN56A4	139
0.89	155	1.4	1520	5000			VF/W 30/63_1520	P56	BN56A4	139
1.1	122	1.7	1200	5000			VF/W 30/63_1200	P56	BN56A4	139
1.5	115	1.8	900	5000			VF/W 30/63_900	P56	BN56A4	139
1.9	113	1.9	720	5000			VF/W 30/63_720	P56	BN56A4	139
2.5	85	1.1	540	3450			VF/VF 30/49_540	P56	BN56A4	134
2.8	50	1.0	500	5000			VFR 44_500	S44	BN44B4	126
3.2	73	1.3	420	3450			VF/VF 30/49_420	P56	BN56A4	134
4.0	54	1.0	350	5000			VFR 44_350	S44	BN44B4	126
4.3	53	1.8	315	3450			VF/VF 30/49_315	P56	BN56A4	134
4.5	59	1.0	300	2500			VFR 44_300	S44	BN44B4	126
5.8	50	1.2	230	2500			VFR 44_230	S44	BN44B4	126
7.7	42	1.5	175	2500			VFR 44_175	S44	BN44B4	126
9.6	36	1.4	140	2500			VFR 44_140	S44	BN44B4	126
13.4	29	1.8	100	2500			VFR 44_100	S44	BN44B4	126
19.1	22	1.8	70	2500			VFR 44_70	S44	BN44B4	126
19.3	14	1.1	70	1600			VF 30_70	P56	BN56A4	122
22.5	13	1.5	60	1600			VF 30_60	P56	BN56A4	122
34	10	0.9	40	600			VF 27_40	P27	BN27B4	121
34	10	1.9	40	1650			VF 30_40	P56	BN56A4	122
45	8	1.1	30	600			VF 27_30	P27	BN27B4	121
45	8	2.4	30	1340			VF 30_30	P56	BN56A4	122
68	6	1.5	20	600			VF 27_20	P27	BN27B4	121
68	6	2.9	20	1180			VF 30_20	P56	BN56A4	122



## 0.06 kW





n <sub>2</sub> min <sup>-1</sup>	M <sub>2</sub> Nm	S	i	R <sub>n2</sub> N	IE1		IE1				
90	5	1.9		15	600			VF 27_15	P27	BN27B4	121
90	5	3.7		15	1080			VF 30_15	P56	BN56A4	122
135	4	2.6		10	590			VF 27_10	P27	BN27B4	121
135	3	4.7		10	950			VF 30_10	P56	BN56A4	122
193	2	3.6		7	530			VF 27_7	P27	BN27B4	121
193	2	6.4		7	840			VF 30_7	P56	BN56A4	122

## 0.09 kW



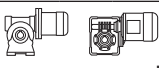

n <sub>2</sub> min <sup>-1</sup>	M <sub>2</sub> Nm	S	i	R <sub>n2</sub> N	IE1		IE1				
0.31	574	1.8		2800	8000			VF/W 49/110_2800	P63	BN63A6	151
0.42	579	1.0		2116	7000			VF/W 44/86_2116	P63	BN63A6	147
0.43	505	2.1		2070	8000			VF/W 49/110_2070	P63	BN63A6	151
0.48	503	1.1		1840	7000			VF/W 44/86_1840	P63	BN63A6	147
0.53	485	2.2		1656	8000			VF/W 49/110_1656	P63	BN63A6	151
0.64	377	1.5		1380	7000			VF/W 44/86_1380	P63	BN63A6	147
0.65	369	2.8		1350	8000			VF/W 49/110_1350	P63	BN63A6	151
0.73	363	1.1		1200	5750			VF/W 44/75_1200	P63	BN63A6	143
0.81	316	3.3		1080	8000			VF/W 49/110_1080	P63	BN63A6	151
0.89	232	0.9		1520	5000			VF/W 30/63_1520	P56	BN56B4	139
0.96	323	1.2		920	5750			VF/W 44/75_920	P63	BN63A6	143
0.96	332	1.7		920	7000			VF/W 44/86_920	P63	BN63A6	147
0.98	255	0.9		900	5000			VF/W 30/63_900	P63	BN63A6	139
1.1	183	1.1		1200	5000			VF/W 30/63_1200	P56	BN56B4	139
1.2	225	1.0		720	5000			VF/W 30/63_720	P63	BN63A6	139
1.3	267	1.5		700	5750			VF/W 44/75_700	P63	BN63A6	143
1.3	253	2.2		700	7000			VF/W 44/86_700	P63	BN63A6	147
1.5	172	1.2		900	5000			VF/W 30/63_900	P56	BN56B4	139
1.7	210	1.9		525	5750			VF/W 44/75_525	P63	BN63A6	143
1.7	200	2.8		525	7000			VF/W 44/86_525	P63	BN63A6	147
1.9	170	1.2		720	5000			VF/W 30/63_720	P56	BN56B4	139
2.2	164	2.4		400	5750			VF/W 44/75_400	P63	BN63A6	143
2.2	160	3.4		400	7000			VF/W 44/86_400	P63	BN63A6	147
2.4	145	1.4		570	5000			VF/W 30/63_570	P56	BN56B4	139
2.9	111	1.2		300	5000			WR 63_300	P63	BN63A6	138
2.9	120	1.7		300	6200			WR 75_300	P63	BN63A6	142
2.9	132	2.4		300	7000			WR 86_300	P63	BN63A6	146
3.0	117	1.8		450	5000			VF/W 30/63_450	P56	BN56B4	139
3.2	110	0.9		420	3450			VF/VF 30/49_420	P56	BN56B4	134
3.7	101	1.4		240	5000			WR 63_240	P63	BN63A6	138
3.7	105	2.1		240	6200			WR 75_240	P63	BN63A6	142
3.7	117	2.6		240	7000			WR 86_240	P63	BN63A6	146
4.2	84	0.9		210	3450			VFR 49_210	P63	BN63A6	132
4.3	80	1.2		315	3450			VF/VF 30/49_315	P56	BN56B4	134
4.3	84	2.5		315	5000			VF/W 30/63_315	P56	BN56B4	139
4.6	88	1.7		192	5000			WR 63_192	P63	BN63A6	138
4.9	79	0.9		180	3450			VFR 49_180	P63	BN63A6	132
4.9	90	3.1		180	6200			WR 75_180	P63	BN63A6	142
5.2	94	4.2		168	7000			WR 86_168	P63	BN63A6	146
5.5	62	1.0		245	2500			VF/VF 30/44_245	P56	BN56B4	128
6.5	66	1.2		135	3450			VFR 49_135	P63	BN63A6	132
6.5	71	2.5		135	5000			WR 63_135	P63	BN63A6	138
7.7	63	1.0		175	2900			VFR 44_175	S44	BN44C4	126
7.7	65	3.1		114	5000			WR 63_114	P63	BN63A6	138
8.1	58	1.4		108	3450			VFR 49_108	P63	BN63A6	132
8.8	41	1.3		100	3300			VF 49_100	P63	BN63A6	130
9.6	54	0.9		140	2900			VFR 44_140	S44	BN44C4	126
9.8	55	3.8		90	5000			WR 63_90	P63	BN63A6	138
10.5	48	1.9		84	3450			VFR 49_84	P63	BN63A6	132
11.0	37	1.6		80	3300			VF 49_80	P63	BN63A6	130
12.2	45	1.8		72	3450			VFR 49_72	P63	BN63A6	132
12.2	48	4.0		72	5000			WR 63_72	P63	BN63A6	138
12.6	35	1.1		70	2300			VF 44_70	P63	BN63A6	124
12.6	34	1.8		70	3300			VF 49_70	P63	BN63A6	130
13.4	43	1.2		100	2900			VFR 44_100	S44	BN44C4	126
14.7	32	1.4		60	2300			VF 44_60	P63	BN63A6	124
14.7	34	1.7		60	3300			VF 49_60	P63	BN63A6	130
16.3	36	2.2		54	3450			VFR 49_54	P63	BN63A6	132
19.1	33	1.2		70	2900			VFR 44_70	S44	BN44C4	126
19.1	27	1.8		46	2300			VF 44_46	P63	BN63A6	124



## 0.09 kW

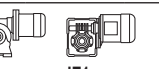



n <sub>2</sub> min <sup>-1</sup>	M <sub>2</sub> Nm	S	i	R <sub>n2</sub> N	 IE1			 IE1			
19.6	26	2.7	45	3300				VF 49_45	P63	BN63A6	130
21.0	30	2.8	42	3360				VFR 49_42	P63	BN63A6	132
22.0	22	0.9	40	1560				VF 30_40	P63	BN63A6	122
22.5	19	1.0	60	1600				VF 30_60	P56	BN56B4	122
24.4	22	3.4	36	3300				VF 49_36	P63	BN63A6	130
25.1	22	2.2	35	2300				VF 44_35	P63	BN63A6	124
29.3	18	1.2	30	1440				VF 30_30	P63	BN63A6	122
31	18	2.7	28	2300				VF 44_28	P63	BN63A6	124
34	15	1.2	40	1410				VF 30_40	P56	BN56B4	122
44	14	1.5	20	1230				VF 30_20	P63	BN63A6	122
44	14	3.1	20	2300				VF 44_20	P63	BN63A6	124
45	12	1.6	30	1290				VF 30_30	P56	BN56B4	122
59	11	1.8	15	1170				VF 30_15	P63	BN63A6	122
68	9	1.9	20	1140				VF 30_20	P56	BN56B4	122
69	9	1.0	20	600				VF 27_20	P27	BN27C4	121
88	8	2.3	10	1050				VF 30_10	P63	BN63A6	122
90	7	2.5	15	1050				VF 30_15	P56	BN56B4	122
92	7	1.3	15	600				VF 27_15	P27	BN27C4	121
126	6	3.2	7	920				VF 30_7	P63	BN63A6	122
135	5	3.1	10	920				VF 30_10	P56	BN56B4	122
138	5	1.7	10	565				VF 27_10	P27	BN27C4	121
193	4	4.3	7	820				VF 30_7	P56	BN56B4	122
197	4	2.5	7	510				VF 27_7	P27	BN27C4	121

## 0.12 kW



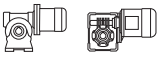

n <sub>2</sub> min <sup>-1</sup>	M <sub>2</sub> Nm	S	i	R <sub>n2</sub> N	 IE1 IE2			 IE1 IE2				
0.31	775	1.4	2800	8000				VF/W 49/110_2800	P63	BN63B6	151	
0.47	588	1.7	2800	8000				VF/W 49/110_2800	P63	BN63A4	BE63A4	151
0.53	654	1.6	1656	8000				VF/W 49/110_1656	P63	BN63B6		151
0.62	518	1.0	2116	7000				VF/W 44/86_2116	P63	BN63A4	BE63A4	147
0.63	507	2.0	2070	8000				VF/W 49/110_2070	P63	BN63A4	BE63A4	151
0.71	483	1.0	1840	7000				VF/W 44/86_1840	P63	BN63A4	BE63A4	147
0.79	435	2.3	1656	8000				VF/W 49/110_1656	P63	BN63A4	BE63A4	151
0.95	386	1.3	1380	7000				VF/W 44/86_1380	P63	BN63A4	BE63A4	147
0.97	354	2.8	1350	8000				VF/W 49/110_1350	P63	BN63A4	BE63A4	151
1.2	293	3.4	1080	8000				VF/W 49/110_1080	P63	BN63A4	BE63A4	151
1.4	322	1.1	920	5750				VF/W 44/75_920	P63	BN63A4	BE63A4	143
1.4	322	1.6	920	7000				VF/W 44/86_920	P63	BN63A4	BE63A4	147
1.5	236	0.9	900	5000				VF/W 30/63_900	P63	BN63A4	BE63A4	139
1.8	233	0.9	720	5000				VF/W 30/63_720	P63	BN63A4	BE63A4	139
1.9	257	1.4	700	5750				VF/W 44/75_700	P63	BN63A4	BE63A4	143
1.9	239	2.1	700	7000				VF/W 44/86_700	P63	BN63A4	BE63A4	147
2.3	199	1.1	570	5000				VF/W 30/63_570	P63	BN63A4	BE63A4	139
2.5	202	1.8	525	5750				VF/W 44/75_525	P63	BN63A4	BE63A4	143
2.5	193	2.6	525	7000				VF/W 44/86_525	P63	BN63A4	BE63A4	147
2.9	150	0.9	300	5000				WR 63_300	P63	BN63B6		138
2.9	162	1.2	300	6200				WR 75_300	P63	BN63B6		142
2.9	178	1.7	300	7000				WR 86_300	P63	BN63B6		146
2.9	161	1.3	450	5000				VF/W 30/63_450	P63	BN63A4	BE63A4	139
3.3	161	2.3	400	5750				VF/W 44/75_400	P63	BN63A4	BE63A4	143
3.3	143	3.5	400	7000				VF/W 44/86_400	P63	BN63A4	BE63A4	147
3.6	136	1.0	240	5000				WR 63_240	P63	BN63B6		138
3.6	142	1.5	240	6200				WR 75_240	P63	BN63B6		142
3.6	142	1.6	240	5000				VF/W 30/63_240	P63	BN63B6		139
3.6	158	2.0	240	7000				WR 86_240	P63	BN63B6		146
4.2	110	0.9	315	3450				VF/VF 30/49_315	P63	BN63A4	BE63A4	134
4.2	116	1.8	315	5000				VF/W 30/63_315	P63	BN63A4	BE63A4	139
4.4	108	1.2	300	5000				WR 63_300	P63	BN63A4	BE63A4	138
4.4	115	1.6	300	6200				WR 75_300	P63	BN63A4	BE63A4	142
4.4	129	2.1	300	7000				WR 86_300	P63	BN63A4	BE63A4	146
4.4	134	2.8	300	5750				VF/W 44/75_300	P63	BN63A4	BE63A4	143
4.8	121	2.3	180	6200				WR 75_180	P63	BN63B6		142
5.2	126	3.1	168	7000				WR 86_168	P63	BN63B6		146
5.2	125	3.0	250	5750				VF/W 44/75_250	P63	BN63A4	BE63A4	143
5.5	94	1.0	240	3450				VF/VF 30/49_240	P63	BN63A4	BE63A4	134
5.5	97	1.4	240	5000				WR 63_240	P63	BN63A4	BE63A4	138
5.5	103	2.1	240	6200				WR 75_240	P63	BN63A4	BE63A4	142
5.5	99	2.1	240	5000				VF/W 30/63_240	P63	BN63A4	BE63A4	139
5.5	111	2.7	240	7000				WR 86_240	P63	BN63A4	BE63A4	146
5.8	109	2.9	150	6200				WR 75_150	P63	BN63B6		142

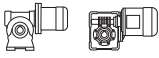

## 0.12 kW

n <sub>2</sub> min <sup>-1</sup>	M <sub>2</sub> Nm	S	i	R <sub>n2</sub> N	 IE1 IE2			 IEC IE1 IE2			
6.4	89	0.9	135	3300			VFR 49_135	P63	BN63B6	132	
6.4	96	1.9	135	5000			WR 63_135	P63	BN63B6	138	
6.8	86	1.8	192	5000			WR 63_192	P63	BN63A4	BE63A4	138
7.3	76	0.9	180	3300			VFR 49_180	P63	BN63A4	BE63A4	132
7.3	87	2.7	180	6200			WR 75_180	P63	BN63A4	BE63A4	142
8.7	55	0.9	100	3300			VF 49_100	P63	BN63B6	130	
9.7	64	1.4	135	3450			VFR 49_135	P63	BN63A4	BE63A4	132
9.7	68	2.5	135	5000			WR 63_135	P63	BN63A4	BE63A4	138
10.9	50	1.2	80	3300			VF 49_80	P63	BN63B6	130	
11.5	61	3.0	114	5000			WR 63_114	P63	BN63A4	BE63A4	138
12.1	55	1.5	108	3450			VFR 49_108	P63	BN63A4	BE63A4	132
13.1	41	1.2	100	3150			VF 49_100	P63	BN63A4	BE63A4	130
14.5	43	1.1	60	2300			VF 44_60	P63	BN63B6	124	
15.3	53	3.6	57	5000			WR 63_57	P63	BN63B6	138	
15.6	46	1.9	84	3450			VFR 49_84	P63	BN63A4	BE63A4	132
16.4	36	1.5	80	3150			VF 49_80	P63	BN63A4	BE63A4	130
18.2	42	1.8	72	3430			VFR 49_72	P63	BN63A4	BE63A4	132
18.7	34	0.9	70	3300			VF 44_70	P63	BN63A4	BE63A4	124
18.7	33	1.7	70	3150			VF 49_70	P63	BN63A4	BE63A4	130
21.8	30	1.3	60	2300			VF 44_60	P63	BN63A4	BE63A4	124
21.8	30	1.9	60	3150			VF 49_60	P63	BN63A4	BE63A4	130
24.3	34	2.2	54	3140			VFR 49_54	P63	BN63A4	BE63A4	132
28.5	25	1.5	46	2300			VF 44_46	P63	BN63A4	BE63A4	124
29.0	24	0.9	30	1360			VF 30_30	P63	BN63B6	122	
29.1	25	2.6	45	3040			VF 49_45	P63	BN63A4	BE63A4	130
31	27	2.9	42	2920			VFR 49_42	P63	BN63A4	BE63A4	132
33	21	0.9	40	1360			VF 30_40	P63	BN63A4	BE63A4	122
36	21	3.3	36	2830			VF 49_36	P63	BN63A4	BE63A4	130
37	21	1.9	35	2300			VF 44_35	P63	BN63A4	BE63A4	124
44	17	1.2	30	1250			VF 30_30	P63	BN63A4	BE63A4	122
47	17	2.2	28	2300			VF 44_28	P63	BN63A4	BE63A4	124
58	15	1.4	15	1130			VF 30_15	P63	BN63B6	122	
62	14	2.7	14	2150			VF 44_14	P63	BN63B6	124	
66	13	1.4	20	1110			VF 30_20	P63	BN63A4	BE63A4	122
66	13	2.9	20	2100			VF 44_20	P63	BN63A4	BE63A4	124
87	10	1.8	15	1020			VF 30_15	P63	BN63A4	BE63A4	122
94	10	2.9	14	1870			VF 44_14	P63	BN63A4	BE63A4	124
124	8	2.4	7	900			VF 30_7	P63	BN63B6	122	
131	7	2.3	10	900			VF 30_10	P63	BN63A4	BE63A4	122
138	6	1.1	20	560			VF 27_20	P27	BN27C2	121	
138	7	2.2	20	840			VF 30_20	P56	BN56B2	122	
183	5	1.4	15	520			VF 27_15	P27	BN27C2	121	
187	5	3.1	7	810			VF 30_7	P63	BN63A4	BE63A4	122
275	4	2.0	10	460			VF 27_10	P27	BN27C2	121	
275	4	3.4	10	740			VF 30_10	P56	BN56B2	122	
393	3	2.8	7	410			VF 27_7	P27	BN27C2	121	
393	3	4.7	7	660			VF 30_7	P56	BN56B2	122	

## 0.12 kW

n <sub>2</sub> min <sup>-1</sup>	M <sub>2</sub> Nm	S	i	R <sub>n2</sub> N	 IE3			 IEC IE3		
0.31	775	1.4	2800	8000			VF/W 49/110_2800	P63	BXN63MA4	151
0.47	588	1.7	2800	8000						
0.53	654	1.6	1656	8000						
0.62	518	1.0	2116	7000			VF/W 44/86_2116	P63	BXN63MA4	147
0.63	507	2.0	2070	8000			VF/W 49/110_2070	P63	BXN63MA4	151
0.71	483	1.0	1840	7000			VF/W 44/86_1840	P63	BXN63MA4	147
0.79	435	2.3	1656	8000			VF/W 49/110_1656	P63	BXN63MA4	151
0.95	386	1.3	1380	7000			VF/W 44/86_1380	P63	BXN63MA4	147
0.97	354	2.8	1350	8000			VF/W 49/110_1350	P63	BXN63MA4	151
1.2	293	3.4	1080	8000			VF/W 49/110_1080	P63	BXN63MA4	151
1.4	322	1.1	920	5750			VF/W 44/75_920	P63	BXN63MA4	143
1.4	322	1.6	920	7000			VF/W 44/86_920	P63	BXN63MA4	147
1.5	236	0.9	900	5000			VF/W 30/63_900	P63	BXN63MA4	139
1.8	233	0.9	720	5000			VF/W 30/63_720	P63	BXN63MA4	139
1.9	257	1.4	700	5750			VF/W 44/75_700	P63	BXN63MA4	143
1.9	239	2.1	700	7000			VF/W 44/86_700	P63	BXN63MA4	147
2.3	199	1.1	570	5000			VF/W 30/63_570	P63	BXN63MA4	139
2.5	202	1.8	525	5750			VF/W 44/75_525	P63	BXN63MA4	143
2.5	193	2.6	525	7000			VF/W 44/86_525	P63	BXN63MA4	147
2.9	150	0.9	300	5000						

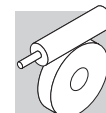





## 0.12 kW

n <sub>2</sub> min <sup>-1</sup>	M <sub>2</sub> Nm	S	i	R <sub>n2</sub> N	IE3		IEC		IEC
2.9	162	1.2	300	6200					
2.9	178	1.7	300	7000					146
2.9	161	1.3	450	5000			VF/W 30/63_450	P63 BXN63MA4	139
3.3	161	2.3	400	5750			VF/W 44/75_400	P63 BXN63MA4	143
3.3	143	3.5	400	7000			VF/W 44/86_400	P63 BXN63MA4	147
3.6	136	1.0	240	5000					
3.6	142	1.5	240	6200					
3.6	142	1.6	240	5000					
3.6	158	2.0	240	7000					
4.2	110	0.9	315	3450			VF/VF 30/49_315	P63 BXN63MA4	134
4.2	116	1.8	315	5000			VF/W 30/63_315	P63 BXN63MA4	139
4.4	108	1.2	300	5000			WR 63_300	P63 BXN63MA4	138
4.4	115	1.6	300	6200			WR 75_300	P63 BXN63MA4	142
4.4	129	2.1	300	7000			WR 86_300	P63 BXN63MA4	146
4.4	134	2.8	300	5750			VF/W 44/75_300	P63 BXN63MA4	143
4.8	121	2.3	180	6200					
5.2	126	3.1	168	7000					
5.2	125	3.0	250	5750			VF/W 44/75_250	P63 BXN63MA4	143
5.5	94	1.0	240	3450			VF/VF 30/49_240	P63 BXN63MA4	134
5.5	97	1.4	240	5000			WR 63_240	P63 BXN63MA4	138
5.5	103	2.1	240	6200			WR 75_240	P63 BXN63MA4	142
5.5	99	2.1	240	5000			VF/W 30/63_240	P63 BXN63MA4	139
5.5	111	2.7	240	7000			WR 86_240	P63 BXN63MA4	146
5.8	109	2.9	150	6200					
6.4	89	0.9	135	3300					
6.4	96	1.9	135	5000					
6.8	86	1.8	192	5000			WR 63_192	P63 BXN63MA4	138
7.3	76	0.9	180	3300			VFR 49_180	P63 BXN63MA4	132
7.3	87	2.7	180	6200			WR 75_180	P63 BXN63MA4	142
8.7	55	0.9	100	3300					
9.7	64	1.4	135	3450			VFR 49_135	P63 BXN63MA4	132
9.7	68	2.5	135	5000			WR 63_135	P63 BXN63MA4	138
10.9	50	1.2	80	3300					
11.5	61	3.0	114	5000			WR 63_114	P63 BXN63MA4	138
12.1	55	1.5	108	3450			VFR 49_108	P63 BXN63MA4	132
13.1	41	1.2	100	3150			VF 49_100	P63 BXN63MA4	130
14.5	43	1.1	60	2300					
15.3	53	3.6	57	5000					
15.6	46	1.9	84	3450			VFR 49_84	P63 BXN63MA4	132
16.4	36	1.5	80	3150			VF 49_80	P63 BXN63MA4	130
18.2	42	1.8	72	3430			VFR 49_72	P63 BXN63MA4	132
18.7	34	0.9	70	3300			VF 44_70	P63 BXN63MA4	124
18.7	33	1.7	70	3150			VF 49_70	P63 BXN63MA4	130
21.8	30	1.3	60	2300			VF 44_60	P63 BXN63MA4	124
21.8	30	1.9	60	3150			VF 49_60	P63 BXN63MA4	130
24.3	34	2.2	54	3140			VFR 49_54	P63 BXN63MA4	132
28.5	25	1.5	46	2300			VF 44_46	P63 BXN63MA4	124
29.0	24	0.9	30	1360					
29.1	25	2.6	45	3040			VF 49_45	P63 BXN63MA4	130
31	27	2.9	42	2920			VFR 49_42	P63 BXN63MA4	132
33	21	0.9	40	1360			VF 30_40	P63 BXN63MA4	122
36	21	3.3	36	2830			VF 49_36	P63 BXN63MA4	130
37	21	1.9	35	2300			VF 44_35	P63 BXN63MA4	124
44	17	1.2	30	1250			VF 30_30	P63 BXN63MA4	122
47	17	2.2	28	2300			VF 44_28	P63 BXN63MA4	124
58	15	1.4	15	1130					
62	14	2.7	14	2150					
66	13	1.4	20	1110			VF 30_20	P63 BXN63MA4	122
66	13	2.9	20	2100			VF 44_20	P63 BXN63MA4	124
87	10	1.8	15	1020			VF 30_15	P63 BXN63MA4	122
94	10	2.9	14	1870			VF 44_14	P63 BXN63MA4	124
124	8	2.4	7	900					
131	7	2.3	10	900			VF 30_10	P63 BXN63MA4	122
138	6	1.1	20	560					
138	7	2.2	20	840					
183	5	1.4	15	520					
187	5	3.1	7	810			VF 30_7	P63 BXN63MA4	122
275	4	2.0	10	460					
275	4	3.4	10	740					
393	3	2.8	7	410					
393	3	4.7	7	660					

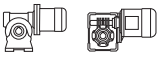



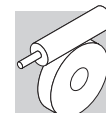

## 0.18 kW

n <sub>2</sub> min <sup>-1</sup>	M <sub>2</sub> Nm	S	i	R <sub>n2</sub> N	 IE1 IE2			 IEC IE1 IE2				
0.28	978	1.9	3200	13800				W/VF 63/130_3200	P71	BN71A6		158
0.28	1345	3.3	3200	19500				W/VF 86/185_3200	P71	BN71A6		174
0.31	1406	1.9	2944	16000				W/VF 86/150_2944	P71	BN71A6		166
0.35	1027	1.8	2560	13800				W/VF 63/130_2560	P71	BN71A6		158
0.35	1320	3.3	2560	19500				W/VF 86/185_2560	P71	BN71A6		174
0.47	875	1.1	2800	8000				VF/W 49/110_2800	P63	BN63B4	BE63B4	151
0.49	1265	2.1	1840	16000				W/VF 86/150_1840	P71	BN71A6		166
0.50	894	2.1	1800	13800				W/VF 63/130_1800	P71	BN71A6		158
0.54	949	1.1	1656	8000				VF/W 49/110_1656	P71	BN71A6		151
0.59	871	2.1	1520	13800				W/VF 63/130_1520	P71	BN71A6		158
0.64	755	1.3	2070	8000				VF/W 49/110_2070	P63	BN63B4	BE63B4	151
0.65	1054	2.6	1380	16000				W/VF 86/150_1380	P71	BN71A6		166
0.75	733	2.5	1200	13800				W/VF 63/130_1200	P71	BN71A6		158
0.80	647	1.5	1656	8000				VF/W 49/110_1656	P63	BN63B4	BE63B4	151
0.94	642	2.9	960	13800				W/VF 63/130_960	P71	BN71A6		158
0.98	527	1.9	1350	8000				VF/W 49/110_1350	P63	BN63B4	BE63B4	151
0.98	756	3.6	920	16000				W/VF 86/150_920	P71	BN71A6		166
1.2	537	3.4	760	13800				W/VF 63/130_760	P71	BN71A6		158
1.2	436	2.3	1080	8000				VF/W 49/110_1080	P63	BN63B4	BE63B4	151
1.4	479	1.0	920	7000				VF/W 44/86_920	P63	BN63B4	BE63B4	147
1.7	391	1.4	525	7000				VF/W 44/86_525	P71	BN71A6		147
1.8	375	2.7	720	8000				VF/W 49/110_720	P63	BN63B4	BE63B4	151
1.9	356	1.4	700	7000				VF/W 44/86_700	P63	BN63B4	BE63B4	147
2.3	321	1.2	400	5750				VF/W 44/75_400	P71	BN71A6		143
2.3	313	1.8	400	7000				VF/W 44/86_400	P71	BN71A6		147
2.3	344	3.1	400	8000				VF/W 49/110_400	P71	BN71A6		151
2.4	288	3.5	540	8000				VF/W 49/110_540	P63	BN63B4	BE63B4	151
2.5	301	1.2	525	5750				VF/W 44/75_525	P63	BN63B4	BE63B4	143
2.5	287	1.7	525	7000				VF/W 44/86_525	P63	BN63B4	BE63B4	147
3.0	258	1.2	300	7000				WR 86_300	P71	BN71A6		146
3.0	264	1.5	300	5750				VF/W 44/75_300	P71	BN71A6		143
3.0	275	2.1	300	8000				WR 110_300	P71	BN71A6		150
3.0	241	2.3	300	7000				VF/W 44/86_300	P71	BN71A6		147
3.0	269	3.9	300	8000				VF/W 49/110_300	P71	BN71A6		151
3.3	240	1.5	400	5750				VF/W 44/75_400	P63	BN63B4	BE63B4	143
3.3	214	2.3	400	7000				VF/W 44/86_400	P63	BN63B4	BE63B4	147
3.8	206	1.1	240	6200				WR 75_240	P71	BN71A6		142
3.8	229	1.4	240	7000				WR 86_240	P71	BN71A6		146
3.8	243	2.4	240	8000				WR 110_240	P71	BN71A6		150
3.9	233	2.4	230	7000				VF/W 44/86_230	P71	BN71A6		147
4.2	172	1.2	315	5000				VF/W 30/63_315	P63	BN63B4	BE63B4	139
4.4	172	1.0	300	6200				WR 75_300	P63	BN63B4	BE63B4	142
4.4	191	1.4	300	7000				WR 86_300	P63	BN63B4	BE63B4	146
4.4	199	1.9	300	5750				VF/W 44/75_300	P63	BN63B4	BE63B4	143
4.4	176	2.8	300	7000				VF/W 44/86_300	P63	BN63B4	BE63B4	147
4.7	202	1.9	192	7000				WR 86_192	P71	BN71A6		146
5.0	175	1.6	180	6200				WR 75_180	P71	BN71A6		142
5.3	186	2.0	250	5750				VF/W 44/75_250	P63	BN63B4	BE63B4	143
5.4	183	2.1	168	7000				WR 86_168	P71	BN71A6		146
5.5	144	0.9	240	5000				WR 63_240	P63	BN63B4	BE63B4	138
5.5	153	1.4	240	6200				WR 75_240	P63	BN63B4	BE63B4	142
5.5	147	1.4	240	5000				VF/W 30/63_240	P63	BN63B4	BE63B4	139
5.5	166	1.8	240	7000				WR 86_240	P63	BN63B4	BE63B4	146
5.7	162	3.1	230	7000				VF/W 44/86_230	P63	BN63B4	BE63B4	147
6.0	158	2.0	150	6200				WR 75_150	P71	BN71A6		142
6.5	161	2.7	138	7000				WR 86_138	P71	BN71A6		146
6.9	128	1.2	192	5000				WR 63_192	P63	BN63B4	BE63B4	138
6.9	145	2.3	192	7000				WR 86_192	P63	BN63B4	BE63B4	146
7.3	129	1.8	180	6200				WR 75_180	P63	BN63B4	BE63B4	142
7.5	138	2.4	120	6200				WR 75_120	P71	BN71A6		142
7.9	131	2.7	168	7000				WR 86_168	P63	BN63B4	BE63B4	146
7.9	126	1.6	114	5000				WR 63_114	P71	BN71A6		138
8.8	113	2.3	150	6200				WR 75_150	P63	BN63B4	BE63B4	142
9.0	88	1.4	100	5000	W 63_100	S1	M1SC6	136	W 63_100	P71	BN71A6	138
9.0	96	1.7	100	6200	W 75_100	S1	M1SC6	140	W 75_100	P71	BN71A6	141
9.0	105	2.4	100	7000	W 86_100	S1	M1SC6	144	W 86_100	P71	BN71A6	145
9.8	102	1.7	135	5000				WR 63_135	P63	BN63B4	BE63B4	138
10.0	107	1.9	90	5000				WR 63_90	P71	BN71A6		138
11.0	98	3.1	120	6200				WR 75_120	P63	BN63B4	BE63B4	142
11.3	79	1.6	80	5000	W 63_80	S1	M1SC6	136	W 63_80	P71	BN71A6	138
11.3	83	2.4	80	6200	W 75_80	S1	M1SC6	140	W 75_80	P71	BN71A6	141
11.3	90	3.1	80	7000	W 86_80	S1	M1SC6	144	W 86_80	P71	BN71A6	145
11.6	91	2.0	114	5000				WR 63_114	P63	BN63B4	BE63B4	138
12.0	100	3.3	75	6200				WR 75_75	P71	BN71A6		142
12.2	82	1.0	108	3450				VFR 49_108	P63	BN63B4	BE63B4	132
14.7	75	2.5	90	5000				WR 63_90	P63	BN63B4	BE63B4	138



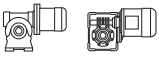



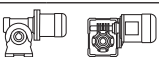

## 0.18 kW

n <sub>2</sub> min-1	M <sub>2</sub> Nm	S	i	R <sub>n2</sub> N	 IE1 IE2			 IEC IE1 IE2				
15.0	61	1.1	60	3000				VF 49_60	P71	BN71A6	130	
15.0	60	1.1	180	3300				VFR 49_180	P63	BN63A2	132	
15.7	68	1.3	84	3420				VFR 49_84	P63	BN63B4	BE63B4	132
16.5	54	1.0	80	3150				VF 49_80	P63	BN63B4	BE63B4	130
18.3	63	1.2	72	3270				VFR 49_72	P63	BN63B4	BE63B4	132
18.3	66	2.8	72	5000				WR 63_72	P63	BN63B4	BE63B4	138
18.9	49	1.1	70	3150				VF 49_70	P63	BN63B4	BE63B4	130
20.0	50	1.4	135	3280				VFR 49_135	P63	BN63A2		132
20.0	54	2.9	45	5000				W 63_45	P71	BN71A6		138
22.0	45	0.9	60	2300				VF 44_60	P63	BN63B4	BE63B4	124
22.0	45	1.3	60	3150				VF 49_60	P63	BN63B4	BE63B4	130
23.2	54	3.3	57	4910				WR 63_57	P63	BN63B4	BE63B4	138
24.4	50	1.5	54	3010				VFR 49_54	P63	BN63B4	BE63B4	132
28.7	38	1.0	46	2500				VF 44_46	P63	BN63B4	BE63B4	124
29.3	37	1.8	45	2300				VF 49_45	P63	BN63B4	BE63B4	130
31	40	1.9	42	2810				VFR 49_42	P63	BN63B4	BE63B4	132
32	36	1.4	28	2290				VF 44_28	P71	BN71A6		124
37	31	2.2	36	2760				VF 49_36	P63	BN63B4	BE63B4	130
38	31	1.3	35	2430				VF 44_35	P63	BN63B4	BE63B4	124
47	26	1.5	28	2270				VF 44_28	P63	BN63B4	BE63B4	124
47	26	2.9	28	2560				VF 49_28	P63	BN63B4	BE63B4	130
55	23	2.7	24	2430				VF 49_24	P63	BN63B4	BE63B4	130
66	19	0.9	20	1040				VF 30_20	P63	BN63B4	BE63B4	122
66	20	1.9	20	2040				VF 44_20	P63	BN63B4	BE63B4	124
73	18	3.2	18	2230				VF 49_18	P63	BN63B4	BE63B4	130
77	16	1.8	35	1970				VF 44_35	P63	BN63A2		124
88	15	1.2	15	960				VF 30_15	P63	BN63B4	BE63B4	122
94	15	2.0	14	1830				VF 44_14	P63	BN63B4	BE63B4	124
132	11	1.5	10	860				VF 30_10	P63	BN63B4	BE63B4	122
132	11	2.7	10	1640				VF 44_10	P63	BN63B4	BE63B4	124
189	8	2.1	7	770				VF 30_7	P63	BN63B4	BE63B4	122
193	7	2.9	14	1470				VF 44_14	P63	BN63A2		124
270	5	2.2	10	710				VF 30_10	P63	BN63A2		122
386	4	3.1	7	640				VF 30_7	P63	BN63A2		122

## 0.18 kW

n <sub>2</sub> min-1	M <sub>2</sub> Nm	S	i	R <sub>n2</sub> N	 IE3			 IEC IE3			
0.28	978	1.9	3200	13800							
0.28	1345	3.3	3200	19500							
0.31	1406	1.9	2944	16000							
0.35	1027	1.8	2560	13800							
0.35	1320	3.3	2560	19500							
0.47	875	1.1	2800	8000				VF/W 49/110_2800	P63	BXN63MB4	151
0.49	1265	2.1	1840	16000							
0.50	894	2.1	1800	13800							
0.54	949	1.1	1656	8000							
0.59	871	2.1	1520	13800							
0.64	755	1.3	2070	8000				VF/W 49/110_2070	P63	BXN63MB4	151
0.65	1054	2.6	1380	16000							
0.75	733	2.5	1200	13800							
0.80	647	1.5	1656	8000				VF/W 49/110_1656	P63	BXN63MB4	151
0.94	642	2.9	960	13800							
0.98	527	1.9	1350	8000				VF/W 49/110_1350	P63	BXN63MB4	151
0.98	756	3.6	920	16000							
1.2	537	3.4	760	13800							
1.2	436	2.3	1080	8000				VF/W 49/110_1080	P63	BXN63MB4	151
1.4	479	1.0	920	7000				VF/W 44/86_920	P63	BXN63MB4	147
1.7	391	1.4	525	7000							
1.8	375	2.7	720	8000				VF/W 49/110_720	P63	BXN63MB4	151
1.9	356	1.4	700	7000				VF/W 44/86_700	P63	BXN63MB4	147
2.3	321	1.2	400	5750							
2.3	313	1.8	400	7000							
2.3	344	3.1	400	8000							
2.4	288	3.5	540	8000				VF/W 49/110_540	P63	BXN63MB4	151
2.5	301	1.2	525	5750				VF/W 44/75_525	P63	BXN63MB4	143
2.5	287	1.7	525	7000				VF/W 44/86_525	P63	BXN63MB4	147
3.0	258	1.2	300	7000							
3.0	264	1.5	300	5750							
3.0	275	2.1	300	8000							
3.0	241	2.3	300	7000							



## 0.18 kW

n <sub>2</sub> min <sup>-1</sup>	M <sub>2</sub> Nm	S	i	R <sub>n2</sub> N	IE3		IEC		
3.0	269	3.9	300	8000					
3.3	240	1.5	400	5750					
3.3	214	2.3	400	7000					
3.8	206	1.1	240	6200					
3.8	229	1.4	240	7000					
3.8	243	2.4	240	8000					
3.9	233	2.4	230	7000					
4.2	172	1.2	315	5000					
4.4	172	1.0	300	6200					
4.4	191	1.4	300	7000					
4.4	199	1.9	300	5750					
4.4	176	2.8	300	7000					
4.7	202	1.9	192	7000					
5.0	175	1.6	180	6200					
5.3	186	2.0	250	5750					
5.4	183	2.1	168	7000					
5.5	144	0.9	240	5000					
5.5	153	1.4	240	6200					
5.5	147	1.4	240	5000					
5.5	166	1.8	240	7000					
5.7	162	3.1	230	7000					
6.0	158	2.0	150	6200					
6.5	161	2.7	138	7000					
6.9	128	1.2	192	5000					
6.9	145	2.3	192	7000					
7.3	129	1.8	180	6200					
7.5	138	2.4	120	6200					
7.9	131	2.7	168	7000					
7.9	126	1.6	114	5000					
8.8	113	2.3	150	6200					
9.0	88	1.4	100	5000					
9.0	96	1.7	100	6200					
9.0	105	2.4	100	7000					
9.8	102	1.7	135	5000					
10.0	107	1.9	90	5000					
11.0	98	3.1	120	6200					
11.3	79	1.6	80	5000					
11.3	83	2.4	80	6200					
11.3	90	3.1	80	7000					
11.6	91	2.0	114	5000					
12.0	100	3.3	75	6200					
12.2	82	1.0	108	3450					
14.7	75	2.5	90	5000					
15.0	61	1.1	60	3000					
15.0	60	1.1	180	3300					
15.7	68	1.3	84	3420					
16.5	54	1.0	80	3150					
18.3	63	1.2	72	3270					
18.3	66	2.8	72	5000					
18.9	49	1.1	70	3150					
20.0	50	1.4	135	3280					
20.0	54	2.9	45	5000					
22.0	45	0.9	60	2300					
22.0	45	1.3	60	3150					
23.2	54	3.3	57	4910					
24.4	50	1.5	54	3010					
28.7	38	1.0	46	2500					
29.3	37	1.8	45	2300					
31	40	1.9	42	2810					
32	36	1.4	28	2290					
37	31	2.2	36	2760					
38	31	1.3	35	2430					
47	26	1.5	28	2270					
47	26	2.9	28	2560					
55	23	2.7	24	2430					
66	19	0.9	20	1040					
66	20	1.9	20	2040					
73	18	3.2	18	2230					
77	16	1.8	35	1970					
88	15	1.2	15	960					
94	15	2.0	14	1830					
132	11	1.5	10	860					
132	11	2.7	10	1640					
189	8	2.1	7	770					
193	7	2.9	14	1470					
270	5	2.2	10	710					
386	4	3.1	7	640					

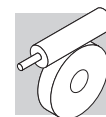

## 0.25 kW

n <sub>2</sub> min <sup>-1</sup>	M <sub>2</sub> Nm	S	i	R <sub>n2</sub> N	IE1 IE2		IEC	IE1 IE2			
0.28	1358	1.4	3200	13800			W/VF 63/130_3200	P71	BN71B6	158	
0.28	1868	2.4	3200	19500			W/VF 86/185_3200	P71	BN71B6	174	
0.31	1952	1.4	2944	16000			W/VF 86/150_2944	P71	BN71B6	166	
0.43	945	1.9	3200	13800			W/VF 63/130_3200	P71	BN71A4	BE71A4	158
0.43	1334	3.1	3200	19500			W/VF 86/185_3200	P71	BN71A4	BE71A4	174
0.47	1380	1.9	2944	16000			W/VF 86/150_2944	P71	BN71A4	BE71A4	166
0.49	1562	2.8	1840	19500			W/VF 86/185_1840	P71	BN71B6		174
0.54	1022	1.8	2560	13800			W/VF 63/130_2560	P71	BN71A4	BE71A4	158
0.54	1289	3.3	2560	19500			W/VF 86/185_2560	P71	BN71A4	BE71A4	174
0.65	1464	1.8	1380	16000			W/VF 86/150_1380	P71	BN71B6		166
0.66	1006	1.0	2070	8000			VF/W 49/110_2070	P71	BN71A4	BE71A4	151
0.75	1214	2.1	1840	16000			W/VF 86/150_1840	P71	BN71A4	BE71A4	166
0.75	1019	1.8	1200	13800			W/VF 63/130_1200	P71	BN71B6		158
0.76	875	2.1	1800	13800			W/VF 63/130_1800	P71	BN71A4	BE71A4	158
0.83	863	1.2	1656	8000			VF/W 49/110_1656	P71	BN71A4	BE71A4	151
0.90	845	2.1	1520	13800			W/VF 63/130_1520	P71	BN71A4	BE71A4	158
0.98	1049	2.6	920	16000			W/VF 86/150_920	P71	BN71B6		166
1.0	1006	2.6	1380	16000			W/VF 86/150_1380	P71	BN71A4	BE71A4	166
1.0	703	1.4	1350	8000			VF/W 49/110_1350	P71	BN71A4	BE71A4	151
1.1	708	2.5	1200	13800			W/VF 63/130_1200	P71	BN71A4	BE71A4	158
1.2	746	2.5	760	13800			W/VF 63/130_760	P71	BN71B6		158
1.3	581	1.7	1080	8000			VF/W 49/110_1080	P71	BN71A4	BE71A4	151
1.3	860	3.1	690	16000			W/VF 86/150_690	P71	BN71B6		166
1.4	617	2.9	960	13800			W/VF 63/130_960	P71	BN71A4	BE71A4	158
1.7	544	1.9	540	8000			VF/W 49/110_540	P71	BN71B6		151
1.7	543	1.0	525	7000			VF/W 44/86_525	P71	BN71B6		147
1.8	515	3.5	760	13800			W/VF 63/130_760	P71	BN71A4	BE71A4	158
1.9	500	2.0	720	8000			VF/W 49/110_720	P71	BN71A4	BE71A4	151
2.0	474	1.1	700	7000			VF/W 44/86_700	P71	BN71A4	BE71A4	147
2.5	384	2.6	540	8000			VF/W 49/110_540	P71	BN71A4	BE71A4	151
2.6	383	1.3	525	7000			VF/W 44/86_525	P71	BN71A4	BE71A4	147
3.0	366	1.1	300	5750			VF/W 44/75_300	P71	BN71B6		143
3.0	382	1.5	300	8000			WR 110_300	P71	BN71B6		150
3.0	374	2.8	300	8000			VF/W 49/110_300	P71	BN71B6		151
3.4	319	1.2	400	5750			VF/W 44/75_400	P71	BN71A4	BE71A4	143
3.4	285	1.8	400	7000			VF/W 44/86_400	P71	BN71A4	BE71A4	147
3.4	313	3.2	400	8000			VF/W 49/110_400	P71	BN71A4	BE71A4	151
3.8	318	1.0	240	7000			WR 86_240	P71	BN71B6		146
3.8	337	1.7	240	8000			WR 110_240	P71	BN71B6		150
3.9	323	1.7	230	7000			VF/W 44/86_230	P71	BN71B6		147
3.9	311	3.4	230	8000			VF/W 49/110_230	P71	BN71B6		151
4.6	255	1.1	300	7000			WR 86_300	P71	BN71A4	BE71A4	146
4.6	266	1.4	300	5750			VF/W 44/75_300	P71	BN71A4	BE71A4	143
4.6	266	2.1	300	8000			WR 110_300	P71	BN71A4	BE71A4	150
4.6	234	2.1	300	7000			VF/W 44/86_300	P71	BN71A4	BE71A4	147
4.7	280	1.4	192	7000			WR 86_192	P71	BN71B6		146
5.5	247	1.5	250	5750			VF/W 44/75_250	P71	BN71A4	BE71A4	143
5.7	204	1.1	240	6200			WR 75_240	P71	BN71A4	BE71A4	142
5.7	221	1.4	240	7000			WR 86_240	P71	BN71A4	BE71A4	146
5.7	233	2.4	240	8000			WR 110_240	P71	BN71A4	BE71A4	150
6.0	216	2.3	230	7000			VF/W 44/86_230	P71	BN71A4	BE71A4	147
6.0	219	1.4	150	6200			WR 75_150	P71	BN71B6		142
6.7	193	0.9	135	5000			WR 63_135	P71	BN71B6		138
7.2	193	1.7	192	7000			WR 86_192	P71	BN71A4	BE71A4	146
7.2	200	3.1	192	8000			WR 110_192	P71	BN71A4	BE71A4	150
7.6	172	1.4	180	6200			WR 75_180	P71	BN71A4	BE71A4	142
7.9	175	1.1	114	5000			WR 63_114	P71	BN71B6		138
8.2	175	2.0	168	7000			WR 86_168	P71	BN71A4	BE71A4	146
9.0	122	1.0	100	5000	W 63_100 S1	M1SD6					136
9.0	133	1.2	100	6200	W 75_100 S1	M1SD6					140
9.0	146	1.7	100	7000	W 86_100 S1	M1SD6					144
9.2	151	1.7	150	6200			W 75_100	P71	BN71B6		141
10.0	151	2.7	138	7000			W 86_100	P71	BN71B6		145
10.0	160	2.3	90	6200			WR 75_150	P71	BN71A4	BE71A4	142
10.2	136	1.3	135	5000			WR 86_138	P71	BN71A4	BE71A4	146
10.2	136	1.3	135	5000			WR 75_90	P71	BN71B6		142
10.2	136	1.3	135	5000			WR 63_135	P71	BN71A4	BE71A4	138
11.3	110	1.1	80	5000	W 63_80 S1	M1SD6					136
11.3	115	1.7	80	6200	W 75_80 S1	M1SD6					140
11.3	125	2.2	80	7000	W 86_80 S1	M1SD6					144
11.5	131	2.3	120	6200			W 86_80	P71	BN71B6		145
11.5	138	2.8	120	7000			WR 75_120	P71	BN71A4	BE71A4	142
11.5	138	2.8	120	7000			WR 86_120	P71	BN71A4	BE71A4	146
12.1	121	1.5	114	5000			WR 63_114	P71	BN71A4	BE71A4	138
13.8	89	1.3	100	5000			W 63_100	P71	BN71A4	BE71A4	138
13.8	96	1.6	100	6200			W 75_100	P71	BN71A4	BE71A4	141
13.8	102	2.2	100	7000			W 86_100	P71	BN71A4	BE71A4	145
15.3	100	1.9	90	5000			WR 63_90	P71	BN71A4	BE71A4	138
15.3	108	3.0	90	6200			WR 75_90	P71	BN71A4	BE71A4	142



### 0.25 kW

n2	M2	S	i	Rn2	IE1 IE2			IEC IE1 IE2				
min-1	Nm			N								
17.2	78	1.5	80	5000				W 63_80	P71	BN71A4	BE71A4	138
17.2	82	2.2	80	6200				W 75_80	P71	BN71A4	BE71A4	141
17.2	89	2.9	80	7000				W 86_80	P71	BN71A4	BE71A4	145
18.3	95	3.1	75	6200				WR 75_75	P71	BN71A4	BE71A4	142
19.1	88	2.1	72	5000				WR 63_72	P71	BN71A4	BE71A4	138
21.5	68	1.8	64	5000				W 63_64	P71	BN71A4	BE71A4	138
22.9	68	3.0	60	6200				W 75_60	P71	BN71A4	BE71A4	141
24.1	72	2.5	57	4780				WR 63_57	P71	BN71A4	BE71A4	138
31	52	2.8	45	4550				W 63_45	P71	BN71A4	BE71A4	138
31	59	3.0	45	4460				WR 63_45	P71	BN71A4	BE71A4	138
32	50	1.0	28	2300				VF 44_28	P71	BN71B6		124
36	46	3.4	38	4320				W 63_38	P71	BN71A4	BE71A4	138
37	44	1.6	36	2670				VF 49_36	P71	BN71A4	BE71A4	130
38	43	0.9	35	2300				VF 44_35	P71	BN71A4	BE71A4	124
38	49	3.3	36	4160				WR 63_36	P71	BN71A4	BE71A4	138
45	39	1.1	20	2190				VF 44_20	P71	BN71B6		124
47	36	1.1	28	2190				VF 44_28	P71	BN71A4	BE71A4	124
47	36	2.1	28	2480				VF 49_28	P71	BN71A4	BE71A4	130
55	33	1.9	24	2360				VF 49_24	P71	BN71A4	BE71A4	130
64	29	1.3	14	1980				VF 44_14	P71	BN71B6		124
64	29	2.5	14	2260				VF 49_14	P71	BN71B6		130
66	28	1.4	20	1970				VF 44_20	P71	BN71A4	BE71A4	124
73	25	2.3	18	2170				VF 49_18	P71	BN71A4	BE71A4	130
77	23	1.3	35	1930				VF 44_35	P63	BN63B2		124
90	22	1.8	10	1780				VF 44_10	P71	BN71B6		124
90	22	2.9	10	2040				VF 49_10	P71	BN71B6		130
94	21	1.4	14	1770				VF 44_14	P71	BN71A4	BE71A4	124
94	21	3.2	14	2010				VF 49_14	P71	BN71A4	BE71A4	130
113	17	2.8	24	1930				VF 49_24	P63	BN63B2		130
129	16	2.5	7	1590				VF 44_7	P71	BN71B6		124
132	15	1.9	10	1590				VF 44_10	P71	BN71A4	BE71A4	124
135	14	1.0	20	840				VF 30_20	P63	BN63B2		122
180	11	1.3	15	780				VF 30_15	P63	BN63B2		122
189	11	2.7	7	1420				VF 44_7	P71	BN71A4	BE71A4	124
270	8	1.6	10	690				VF 30_10	P63	BN63B2		122
270	8	2.9	10	1300				VF 44_10	P63	BN63B2		124
386	5	2.2	7	620				VF 30_7	P63	BN63B2		122

### 0.25 kW

n2	M2	S	i	Rn2	IE3			IEC IE3				
min-1	Nm			N								
0.28	1358	1.4	3200	13800								
0.28	1868	2.4	3200	19500								
0.31	1952	1.4	2944	16000								
0.43	945	1.9	3200	13800	W/VF 63/130_3200	S10	MXN10MA4	158	W/VF 63/130_3200	P71	BXN71MA4	158
0.43	1334	3.1	3200	19500	W/VF 86/185_3200	S10	MXN10MA4	174	W/VF 86/185_3200	P71	BXN71MA4	174
0.47	1380	1.9	2944	16000	W/VF 86/150_2944	S10	MXN10MA4	166	W/VF 86/150_2944	P71	BXN71MA4	166
0.49	1562	2.8	1840	19500								
0.54	1022	1.8	2560	13800	W/VF 63/130_2560	S10	MXN10MA4	158	W/VF 63/130_2560	P71	BXN71MA4	158
0.54	1289	3.3	2560	19500	W/VF 86/185_2560	S10	MXN10MA4	174	W/VF 86/185_2560	P71	BXN71MA4	174
0.65	1464	1.8	1380	16000								
0.66	1006	1.0	2070	8000					VF/W 49/110_2070	P71	BXN71MA4	151
0.75	1214	2.1	1840	16000	W/VF 86/150_1840	S10	MXN10MA4	166	W/VF 86/150_1840	P71	BXN71MA4	166
0.75	1019	1.8	1200	13800								
0.76	875	2.1	1800	13800	W/VF 63/130_1800	S10	MXN10MA4	158	W/VF 63/130_1800	P71	BXN71MA4	158
0.83	863	1.2	1656	8000					VF/W 49/110_1656	P71	BXN71MA4	151
0.90	845	2.1	1520	13800	W/VF 63/130_1520	S10	MXN10MA4	158	W/VF 63/130_1520	P71	BXN71MA4	158
0.98	1049	2.6	920	16000								
1.0	1006	2.6	1380	16000	W/VF 86/150_1380	S10	MXN10MA4	166	W/VF 86/150_1380	P71	BXN71MA4	166
1.0	703	1.4	1350	8000					VF/W 49/110_1350	P71	BXN71MA4	151
1.1	708	2.5	1200	13800	W/VF 63/130_1200	S10	MXN10MA4	158	W/VF 63/130_1200	P71	BXN71MA4	158
1.2	746	2.5	760	13800								
1.3	581	1.7	1080	8000					VF/W 49/110_1080	P71	BXN71MA4	151
1.3	860	3.1	690	16000								
1.4	617	2.9	960	13800	W/VF 63/130_960	S10	MXN10MA4	158	W/VF 63/130_960	P71	BXN71MA4	158
1.7	544	1.9	540	8000								
1.7	543	1.0	525	7000								
1.8	515	3.5	760	13800	W/VF 63/130_760	S10	MXN10MA4	158	W/VF 63/130_760	P71	BXN71MA4	158
1.9	500	2.0	720	8000					VF/W 49/110_720	P71	BXN71MA4	151
2.0	474	1.1	700	7000					VF/W 44/86_700	P71	BXN71MA4	147
2.5	384	2.6	540	8000					VF/W 49/110_540	P71	BXN71MA4	151

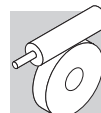

## 0.25 kW

n <sub>2</sub> min-1	M <sub>2</sub> Nm	S	i	R <sub>n2</sub> N	 IE3			 IEC			 IE3			
2.6	383	1.3	525	7000						VF/W 44/86_525	P71	BXN71MA4	147	
3.0	366	1.1	300	5750										
3.0	382	1.5	300	8000										
3.0	374	2.8	300	8000										
3.4	319	1.2	400	5750						VF/W 44/75_400	P71	BXN71MA4	143	
3.4	285	1.8	400	7000						VF/W 44/86_400	P71	BXN71MA4	147	
3.4	313	3.2	400	8000						VF/W 49/110_400	P71	BXN71MA4	151	
3.8	318	1.0	240	7000										
3.8	337	1.7	240	8000										
3.9	323	1.7	230	7000										
3.9	311	3.4	230	8000										
4.6	255	1.1	300	7000						WR 86_300	P71	BXN71MA4	146	
4.6	266	1.4	300	5750						VF/W 44/75_300	P71	BXN71MA4	143	
4.6	266	2.1	300	8000						WR 110_300	P71	BXN71MA4	150	
4.6	234	2.1	300	7000						VF/W 44/86_300	P71	BXN71MA4	147	
4.7	280	1.4	192	7000										
5.5	247	1.5	250	5750						VF/W 44/75_250	P71	BXN71MA4	143	
5.7	204	1.1	240	6200						WR 75_240	P71	BXN71MA4	142	
5.7	221	1.4	240	7000						WR 86_240	P71	BXN71MA4	146	
5.7	233	2.4	240	8000						WR 110_240	P71	BXN71MA4	150	
6.0	216	2.3	230	7000						VF/W 44/86_230	P71	BXN71MA4	147	
6.0	219	1.4	150	6200										
6.7	193	0.9	135	5000										
7.2	193	1.7	192	7000						WR 86_192	P71	BXN71MA4	146	
7.2	200	3.1	192	8000						WR 110_192	P71	BXN71MA4	150	
7.6	172	1.4	180	6200						WR 75_180	P71	BXN71MA4	142	
7.9	175	1.1	114	5000										
8.2	175	2.0	168	7000						WR 86_168	P71	BXN71MA4	146	
9.0	122	1.0	100	5000										
9.0	133	1.2	100	6200										
9.0	146	1.7	100	7000										
9.2	151	1.7	150	6200						WR 75_150	P71	BXN71MA4	142	
10.0	151	2.7	138	7000						WR 86_138	P71	BXN71MA4	146	
10.0	160	2.3	90	6200										
10.2	136	1.3	135	5000						WR 63_135	P71	BXN71MA4	138	
11.3	110	1.1	80	5000										
11.3	115	1.7	80	6200										
11.3	125	2.2	80	7000										
11.5	131	2.3	120	6200						WR 75_120	P71	BXN71MA4	142	
11.5	138	2.8	120	7000						WR 86_120	P71	BXN71MA4	146	
12.1	121	1.5	114	5000						WR 63_114	P71	BXN71MA4	138	
13.8	89	1.3	100	5000	W 63_100	S10	MXN10MA4	138	W 63_100	P71	BXN71MA4	138	138	
13.8	96	1.6	100	6200	W 75_100	S10	MXN10MA4	141	W 75_100	P71	BXN71MA4	141	141	
13.8	102	2.2	100	7000	W 86_100	S10	MXN10MA4	145	W 86_100	P71	BXN71MA4	145	145	
15.3	100	1.9	90	5000						WR 63_90	P71	BXN71MA4	138	138
15.3	108	3.0	90	6200						WR 75_90	P71	BXN71MA4	142	142
17.2	78	1.5	80	5000	W 63_80	S10	MXN10MA4	138	W 63_80	P71	BXN71MA4	138	138	
17.2	82	2.2	80	6200	W 75_80	S10	MXN10MA4	141	W 75_80	P71	BXN71MA4	141	141	
17.2	89	2.9	80	7000	W 86_80	S10	MXN10MA4	145	W 86_80	P71	BXN71MA4	145	145	
18.3	95	3.1	75	6200						WR 75_75	P71	BXN71MA4	142	142
19.1	88	2.1	72	5000						WR 63_72	P71	BXN71MA4	138	138
21.5	68	1.8	64	5000	W 63_64	S10	MXN10MA4	138	W 63_64	P71	BXN71MA4	138	138	
22.9	68	3.0	60	6200	W 75_60	S10	MXN10MA4	141	W 75_60	P71	BXN71MA4	141	141	
24.1	72	2.5	57	4780						WR 63_57	P71	BXN71MA4	138	138
31	52	2.8	45	4550	W 63_45	S10	MXN10MA4	138	W 63_45	P71	BXN71MA4	138	138	
31	59	3.0	45	4460						WR 63_45	P71	BXN71MA4	138	138
32	50	1.0	28	2300										
36	46	3.4	38	4320	W 63_38	S10	MXN10MA4	138	W 63_38	P71	BXN71MA4	138	138	
37	44	1.6	36	2670						VF 49_36	P71	BXN71MA4	130	130
38	43	0.9	35	2300						VF 44_35	P71	BXN71MA4	124	124
38	49	3.3	36	4160						WR 63_36	P71	BXN71MA4	138	138
45	39	1.1	20	2190										
47	36	1.1	28	2190						VF 44_28	P71	BXN71MA4	124	124
47	36	2.1	28	2480						VF 49_28	P71	BXN71MA4	130	130
55	33	1.9	24	2360						VF 49_24	P71	BXN71MA4	130	130
64	29	1.3	14	1980										
64	29	2.5	14	2260										
66	28	1.4	20	1970						VF 44_20	P71	BXN71MA4	124	124
73	25	2.3	18	2170						VF 49_18	P71	BXN71MA4	130	130
77	23	1.3	35	1930										
90	22	1.8	10	1780										
90	22	2.9	10	2040										
94	21	1.4	14	1770										
94	21	3.2	14	2010						VF 44_14	P71	BXN71MA4	124	124
113	17	2.8	24	1930						VF 49_14	P71	BXN71MA4	130	130
129	16	2.5	7	1590										

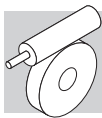

## 0.25 kW

n <sub>2</sub> min <sup>-1</sup>	M <sub>2</sub> Nm	S	i	R <sub>n2</sub> N	 IE3		 IEC		
					VF 44_10	P71	BNX71MA4		
132	15	1.9	10	1590					124
135	14	1.0	20	840					
180	11	1.3	15	780					
189	11	2.7	7	1420					
270	8	1.6	10	690					
270	8	2.9	10	1300					
386	5	2.2	7	620					

## 0.37 kW

n <sub>2</sub> min <sup>-1</sup>	M <sub>2</sub> Nm	S	i	R <sub>n2</sub> N	 IE1 IE2		 IEC				
					W/VF	P80	BN80A6	BE71B4			
0.28	2734	1.6	3200	19500			W/VF 86/150_3200	P80	BN80A6		174
0.31	2858	0.9	2944	16000			W/VF 86/150_2944	P80	BN80A6		166
0.36	2684	1.6	2560	19500			W/VF 86/185_2560	P80	BN80A6		174
0.43	1403	1.3	3200	13800			W/VF 63/130_3200	P71	BN71B4	BE71B4	158
0.43	1981	2.1	3200	19500			W/VF 86/185_3200	P71	BN71B4	BE71B4	174
0.47	2050	1.3	2944	16000			W/VF 86/150_2944	P71	BN71B4	BE71B4	166
0.54	1519	1.2	2560	13800			W/VF 63/130_2560	P71	BN71B4	BE71B4	158
0.54	1915	2.2	2560	19500			W/VF 86/185_2560	P71	BN71B4	BE71B4	174
0.60	1771	1.0	1520	13800			W/VF 63/130_1520	P80	BN80A6		158
0.66	2143	1.3	1380	16000			W/VF 86/150_1380	P80	BN80A6		166
0.74	1803	1.4	1840	16000			W/VF 86/150_1840	P71	BN71B4	BE71B4	166
0.74	1614	2.6	1840	19500			W/VF 86/185_1840	P71	BN71B4	BE71B4	174
0.76	1300	1.4	1800	13800			W/VF 63/130_1800	P71	BN71B4	BE71B4	158
0.86	1444	2.9	1600	19500			W/VF 86/185_1600	P71	BN71B4	BE71B4	174
0.90	1255	1.4	1520	13800			W/VF 63/130_1520	P71	BN71B4	BE71B4	158
0.99	1357	3.2	920	19500			W/VF 86/185_920	P80	BN80A6		174
1.0	1495	1.7	1380	16000			W/VF 86/150_1380	P71	BN71B4	BE71B4	166
1.0	1045	1.0	1350	8000			VF/W 49/110_1350	P71	BN71B4	BE71B4	151
1.1	1052	1.7	1200	13800			W/VF 63/130_1200	P71	BN71B4	BE71B4	158
1.3	864	1.2	1080	8000			VF/W 49/110_1080	P71	BN71B4	BE71B4	151
1.3	1259	2.1	690	16000			W/VF 86/150_690	P80	BN80A6		166
1.4	916	2.0	960	13800			W/VF 63/130_960	P71	BN71B4	BE71B4	158
1.5	1068	2.4	920	16000			W/VF 86/150_920	P71	BN71B4	BE71B4	166
1.7	797	1.3	540	8000			VF/W 49/110_540	P80	BN80A6		151
1.7	1068	2.5	529	16000			W/VF 86/150_529	P80	BN80A6		166
1.8	764	2.4	760	13800			W/VF 63/130_760	P71	BN71B4	BE71B4	158
1.9	743	1.3	720	8000			VF/W 49/110_720	P71	BN71B4	BE71B4	151
2.0	890	2.9	690	16000			W/VF 86/150_690	P71	BN71B4	BE71B4	166
2.3	619	2.9	600	13800			W/VF 63/130_600	P71	BN71B4	BE71B4	158
2.5	571	1.8	540	8000			VF/W 49/110_540	P71	BN71B4	BE71B4	151
2.6	750	3.5	529	16000			W/VF 86/150_529	P71	BN71B4	BE71B4	166
3.0	559	1.0	300	8000			WR 110_300	P80	BN80A6		150
3.0	571	1.8	300	13800			VFR 130_300	P80	BN80A6		154
3.0	547	1.9	300	8000			VF/W 49/110_300	P80	BN80A6		151
3.4	423	1.2	400	7000			VF/W 44/86_400	P71	BN71B4	BE71B4	147
3.4	464	2.2	400	8000			VF/W 49/110_400	P71	BN71B4	BE71B4	151
3.8	494	1.2	240	8000			WR 110_240	P80	BN80A6		150
3.8	503	2.4	240	13800			VFR 130_240	P80	BN80A6		154
4.0	455	2.3	230	8000			VF/W 49/110_230	P80	BN80A6		151
4.6	395	1.4	300	8000			WR 110_300	P71	BN71B4	BE71B4	150
4.6	348	1.4	300	7000			VF/W 44/86_300	P71	BN71B4	BE71B4	147
4.6	371	2.7	300	8000			VF/W 49/110_300	P71	BN71B4	BE71B4	151
4.7	410	1.0	192	7000			WR 86_192	P80	BN80A6		146
4.7	425	1.6	192	8000			WR 110_192	P80	BN80A6		150
4.7	432	3.0	192	13800			VFR 130_192	P80	BN80A6		154
5.4	372	1.0	168	7000			WR 86_168	P80	BN80A6		146
5.4	391	2.0	168	8000			WR 110_168	P80	BN80A6		150
5.4	391	3.4	168	13800			VFR 130_168	P80	BN80A6		154
5.7	328	0.9	240	7000			WR 86_240	P71	BN71B4	BE71B4	146
5.7	347	1.6	240	8000			WR 110_240	P71	BN71B4	BE71B4	150
6.0	320	1.6	230	7000			VF/W 44/86_230	P71	BN71B4	BE71B4	147
6.0	308	3.2	230	8000			VF/W 49/110_230	P71	BN71B4	BE71B4	151
6.1	320	1.0	150	6200			WR 75_150	P80	BN80A6		142
6.6	327	1.3	138	7000			WR 86_138	P80	BN80A6		146
6.6	338	2.4	138	8000			WR 110_138	P80	BN80A6		150
7.1	287	1.1	192	7000			WR 86_192	P71	BN71B4	BE71B4	146



## 0.37 kW

n <sub>2</sub> min-1	M <sub>2</sub> Nm	S	i	R <sub>n2</sub> N						
					IE1	IE2		IE1	IE2	
7.1	297	2.1	192	8000				WR 110_192	P71 BN71B4 BE71B4	150
7.6	294	1.5	120	7000				WR 86_120	P80 BN80A6	146
7.6	303	2.9	120	8000				WR 110_120	P80 BN80A6	150
7.6	255	0.9	180	6200				WR 75_180	P71 BN71B4 BE71B4	142
8.2	260	1.4	168	7000				WR 86_168	P71 BN71B4 BE71B4	146
8.2	273	2.6	168	8000				WR 110_168	P71 BN71B4 BE71B4	150
9.1	214	1.2	100	7000	W 86_100	S1 M1LA6	144	W 86_100	P80 BN80A6	145
9.1	224	1.2	150	6200				WR 75_150	P71 BN71B4 BE71B4	142
9.9	224	1.8	138	7000				WR 86_138	P71 BN71B4 BE71B4	146
9.9	235	3.0	138	8000				WR 110_138	P71 BN71B4 BE71B4	150
10.1	234	1.6	90	6200				WR 75_90	P80 BN80A6	142
11.4	168	1.2	80	6200	W 75_80	S1 M1LA6	140	W 75_80	P80 BN80A6	141
11.4	183	1.5	80	7000	W 86_80	S1 M1LA6	144	W 86_80	P80 BN80A6	145
11.4	195	1.6	120	6200				WR 75_120	P71 BN71B4 BE71B4	142
11.4	204	1.9	120	7000				WR 86_120	P71 BN71B4 BE71B4	146
12.0	179	1.0	114	5000				WR 63_114	P71 BN71B4 BE71B4	138
12.1	204	1.6	75	6200				WR 75_75	P80 BN80A6 BN80A6	142
13.2	196	2.0	69	7000				WR 86_69	P80 BN80A6	146
13.7	142	1.1	100	6200	W 75_100	S1 M1SD4 ME1SB4	140	W 75_100	P71 BN71B4 BE71B4	141
13.7	152	1.5	100	7000	W 86_100	S1 M1SD4 ME1SB4	144	W 86_100	P71 BN71B4 BE71B4	145
14.2	139	1.0	64	5000	W 63_64	S1 M1LA6	136	W 63_64	P80 BN80A6	138
15.2	140	1.5	60	6200	W 75_60	S1 M1LA6	140	W 75_60	P80 BN80A6	141
15.2	149	1.3	90	5000				WR 63_90	P71 BN71B4 BE71B4	138
15.2	160	2.0	90	6200				WR 75_90	P71 BN71B4 BE71B4	142
15.2	156	2.8	90	7000				WR 86_90	P71 BN71B4 BE71B4	146
16.3	144	2.3	56	7000	W 86_56	S1 M1LA6	144	W 86_56	P80 BN80A6	145
17.1	116	1.0	80	5000	W 63_80	S1 M1SD4 ME1SB4	136	W 63_80	P71 BN71B4 BE71B4	138
17.1	122	1.5	80	6200	W 75_80	S1 M1SD4 ME1SB4	140	W 75_80	P71 BN71B4 BE71B4	141
17.1	132	1.9	80	7000	W 86_80	S1 M1SD4 ME1SB4	144	W 86_80	P71 BN71B4 BE71B4	145
18.3	141	2.1	75	6200				WR 75_75	P71 BN71B4 BE71B4	142
19.0	130	1.4	72	4830				WR 63_72	P71 BN71B4 BE71B4	138
19.9	133	2.8	69	7000				WR 86_69	P71 BN71B4 BE71B4	146
20.2	136	2.6	45	6200				WR 75_45	P80 BN80A6	142
21.4	101	1.2	64	4870	W 63_64	S1 M1SD4 ME1SB4	136	W 63_64	P71 BN71B4 BE71B4	138
21.4	112	2.5	64	7000	W 86_64	S1 M1SD4 ME1SB4	144	W 86_64	P71 BN71B4 BE71B4	145
22.8	101	2.0	60	6200	W 75_60	S1 M1SD4 ME1SB4	140	W 75_60	P71 BN71B4 BE71B4	141
22.8	119	2.5	60	6200				WR 75_60	P71 BN71B4 BE71B4	142
22.8	119	3.2	60	7000				WR 86_60	P71 BN71B4 BE71B4	146
24.0	107	1.7	57	4540				WR 63_57	P71 BN71B4 BE71B4	138
24.5	101	3.0	56	7000	W 86_56	S1 M1SD4 ME1SB4	144	W 86_56	P71 BN71B4 BE71B4	145
27.4	88	2.5	50	6200	W 75_50	S1 M1SD4 ME1SB4	140	W 75_50	P71 BN71B4 BE71B4	141
30	73	0.9	45	2680				VF 49_45	P71 BN71B4 BE71B4	130
30	78	1.9	45	4400	W 63_45	S1 M1SD4 ME1SB4	136	W 63_45	P71 BN71B4 BE71B4	138
30	88	2.0	45	4250				WR 63_45	P71 BN71B4 BE71B4	138
30	93	3.2	45	5880				WR 75_45	P71 BN71B4 BE71B4	142
34	74	3.4	40	5820	W 75_40	S1 M1SD4 ME1SB4	140	W 75_40	P71 BN71B4 BE71B4	141
36	69	2.3	38	4180	W 63_38	S1 M1SD4 ME1SB4	136	W 63_38	P71 BN71B4 BE71B4	138
38	62	1.1	36	2530				VF 49_36	P71 BN71B4 BE71B4	130
38	73	2.2	36	3980				WR 63_36	P71 BN71B4 BE71B4	138
46	57	2.8	30	3900	W 63_30	S1 M1SD4 ME1SB4	136	W 63_30	P71 BN71B4 BE71B4	138
49	51	1.4	28	2360				VF 49_28	P71 BN71B4 BE71B4	130
57	46	1.4	24	2250				VF 49_24	P71 BN71B4 BE71B4	130
57	48	3.2	24	3650	W 63_24	S1 M1SD4 ME1SB4	136	W 63_24	P71 BN71B4 BE71B4	138
65	42	1.7	14	1940				VF 49_14	P80 BN80A6	130
69	40	1.0	20	1870				VF 44_20	P71 BN71B4 BE71B4	124
72	40	3.8	19	3400	W 63_19	S1 M1SD4 ME1SB4	136	W 63_19	P71 BN71B4 BE71B4	138
76	36	1.6	18	2080				VF 49_18	P71 BN71B4 BE71B4	130
79	33	0.9	35	1860				VF 44_35	P71 BN71A2	124
91	32	2.0	10	1930				VF 49_10	P80 BN80A6	130
98	29	1.0	14	1690				VF 44_14	P71 BN71B4 BE71B4	124
98	29	2.2	14	1940				VF 49_14	P71 BN71B4 BE71B4	130
117	24	2.0	24	1880				VF 49_24	P71 BN71A2	130
137	22	1.3	10	1520				VF 44_10	P71 BN71B4 BE71B4	124
137	22	2.7	10	1750				VF 49_10	P71 BN71B4 BE71B4	130
138	21	1.4	20	1570				VF 44_20	P71 BN71A2	124
153	19	2.3	18	1720				VF 49_18	P71 BN71A2	130
196	16	1.9	7	1360				VF 44_7	P71 BN71B4 BE71B4	124
196	16	3.5	7	1570				VF 49_7	P71 BN71B4 BE71B4	130
275	11	2.0	10	1260				VF 44_10	P71 BN71A2	124
393	8	2.8	7	1120				VF 44_7	P71 BN71A2	124

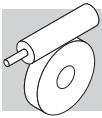

## 0.37 kW

n <sub>2</sub> min-1	M <sub>2</sub> Nm	S	i	R <sub>n2</sub> N		IE3			IEC			
									IE3			
0.28	2734	1.6	3200	19500								
0.31	2858	0.9	2944	16000								
0.36	2684	1.6	2560	19500								
0.43	1403	1.3	3200	13800	W/VF 63/130_3200	S10	MXN10MB4	158	W/VF 63/130_3200	P71	BXN71MB4	158
0.43	1981	2.1	3200	19500	W/VF 86/185_3200	S10	MXN10MB4	174	W/VF 86/185_3200	P71	BXN71MB4	174
0.47	2050	1.3	2944	16000	W/VF 86/150_2944	S10	MXN10MB4	166	W/VF 86/150_2944	P71	BXN71MB4	166
0.54	1519	1.2	2560	13800	W/VF 63/130_2560	S10	MXN10MB4	158	W/VF 63/130_2560	P71	BXN71MB4	158
0.54	1915	2.2	2560	19500	W/VF 86/185_2560	S10	MXN10MB4	174	W/VF 86/185_2560	P71	BXN71MB4	174
0.60	1771	1.0	1520	13800								
0.66	2143	1.3	1380	16000								
0.74	1803	1.4	1840	16000	W/VF 86/150_1840	S10	MXN10MB4	166	W/VF 86/150_1840	P71	BXN71MB4	166
0.74	1614	2.6	1840	19500	W/VF 86/185_1840	S10	MXN10MB4	174	W/VF 86/185_1840	P71	BXN71MB4	174
0.76	1300	1.4	1800	13800	W/VF 63/130_1800	S10	MXN10MB4	158	W/VF 63/130_1800	P71	BXN71MB4	158
0.86	1444	2.9	1600	19500	W/VF 86/185_1600	S10	MXN10MB4	174	W/VF 86/185_1600	P71	BXN71MB4	174
0.90	1255	1.4	1520	13800	W/VF 63/130_1520	S10	MXN10MB4	158	W/VF 63/130_1520	P71	BXN71MB4	158
0.99	1357	3.2	920	19500								
1.0	1495	1.7	1380	16000	W/VF 86/150_1380	S10	MXN10MB4	166	W/VF 86/150_1380	P71	BXN71MB4	166
1.0	1045	1.0	1350	8000					VF/W 49/110_1350	P71	BXN71MB4	151
1.1	1052	1.7	1200	13800	W/VF 63/130_1200	S10	MXN10MB4	158	W/VF 63/130_1200	P71	BXN71MB4	158
1.3	864	1.2	1080	8000					VF/W 49/110_1080	P71	BXN71MB4	151
1.3	1259	2.1	690	16000								
1.4	916	2.0	960	13800	W/VF 63/130_960	S10	MXN10MB4	158	W/VF 63/130_960	P71	BXN71MB4	158
1.5	1068	2.4	920	16000	W/VF 86/150_920	S10	MXN10MB4	166	W/VF 86/150_920	P71	BXN71MB4	166
1.7	797	1.3	540	8000								
1.7	1068	2.5	529	16000								
1.8	764	2.4	760	13800	W/VF 63/130_760	S10	MXN10MB4	158	W/VF 63/130_760	P71	BXN71MB4	158
1.9	743	1.3	720	8000					VF/W 49/110_720	P71	BXN71MB4	151
2.0	890	2.9	690	16000	W/VF 86/150_690	S10	MXN10MB4	166	W/VF 86/150_690	P71	BXN71MB4	166
2.3	619	2.9	600	13800	W/VF 63/130_600	S10	MXN10MB4	158	W/VF 63/130_600	P71	BXN71MB4	158
2.5	571	1.8	540	8000					VF/W 49/110_540	P71	BXN71MB4	151
2.6	750	3.5	529	16000	W/VF 86/150_529	S10	MXN10MB4	166	W/VF 86/150_529	P71	BXN71MB4	166
3.0	559	1.0	300	8000								
3.0	571	1.8	300	13800								
3.0	547	1.9	300	8000								
3.4	423	1.2	400	7000					VF/W 44/86_400	P71	BXN71MB4	147
3.4	464	2.2	400	8000					VF/W 49/110_400	P71	BXN71MB4	151
3.8	494	1.2	240	8000								
3.8	503	2.4	240	13800								
4.0	455	2.3	230	8000								
4.6	395	1.4	300	8000					WR 110_300	P71	BXN71MB4	150
4.6	348	1.4	300	7000					VF/W 44/86_300	P71	BXN71MB4	147
4.6	371	2.7	300	8000					VF/W 49/110_300	P71	BXN71MB4	151
4.7	410	1.0	192	7000								
4.7	425	1.6	192	8000								
4.7	432	3.0	192	13800								
5.4	372	1.0	168	7000								
5.4	391	2.0	168	8000								
5.4	391	3.4	168	13800								
5.7	328	0.9	240	7000					WR 86_240	P71	BXN71MB4	146
5.7	347	1.6	240	8000					WR 110_240	P71	BXN71MB4	150
6.0	320	1.6	230	7000					VF/W 44/86_230	P71	BXN71MB4	147
6.0	308	3.2	230	8000					VF/W 49/110_230	P71	BXN71MB4	151
6.1	320	1.0	150	6200								
6.6	327	1.3	138	7000								
6.6	338	2.4	138	8000								
7.1	287	1.1	192	7000					WR 86_192	P71	BXN71MB4	146
7.1	297	2.1	192	8000					WR 110_192	P71	BXN71MB4	150
7.6	294	1.5	120	7000								
7.6	303	2.9	120	8000								
7.6	255	0.9	180	6200					WR 75_180	P71	BXN71MB4	142
8.2	260	1.4	168	7000					WR 86_168	P71	BXN71MB4	146
8.2	273	2.6	168	8000					WR 110_168	P71	BXN71MB4	150
9.1	214	1.2	100	7000								
9.1	224	1.2	150	6200					WR 75_150	P71	BXN71MB4	142
9.9	224	1.8	138	7000					WR 86_138	P71	BXN71MB4	146
9.9	235	3.0	138	8000					WR 110_138	P71	BXN71MB4	150
10.1	234	1.6	90	6200								
11.4	168	1.2	80	6200								
11.4	183	1.5	80	7000								
11.4	195	1.6	120	6200					WR 75_120	P71	BXN71MB4	142
11.4	204	1.9	120	7000					WR 86_120	P71	BXN71MB4	146



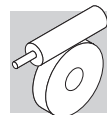

## 0.37 kW

n <sub>2</sub> min-1	M <sub>2</sub> Nm	S	i	R <sub>n2</sub> N	 IE3			 IE3				
12.0	179	1.0	114	5000				WR 63_114	P71	BXN71MB4	138	
12.1	204	1.6	75	6200								
13.2	196	2.0	69	7000								
13.7	142	1.1	100	6200	W 75_100	S10	MXN10MB4	140	W 75_100	P71	BXN71MB4	141
13.7	152	1.5	100	7000	W 86_100	S10	MXN10MB4	144	W 86_100	P71	BXN71MB4	145
14.2	139	1.0	64	5000								
15.2	140	1.5	60	6200								
15.2	149	1.3	90	5000				WR 63_90	P71	BXN71MB4	138	
15.2	160	2.0	90	6200				WR 75_90	P71	BXN71MB4	142	
15.2	156	2.8	90	7000				WR 86_90	P71	BXN71MB4	146	
16.3	144	2.3	56	7000								
17.1	116	1.0	80	5000	W 63_80	S10	MXN10MB4	136	W 63_80	P71	BXN71MB4	138
17.1	122	1.5	80	6200	W 75_80	S10	MXN10MB4	140	W 75_80	P71	BXN71MB4	141
17.1	132	1.9	80	7000	W 86_80	S10	MXN10MB4	144	W 86_80	P71	BXN71MB4	145
18.3	141	2.1	75	6200				WR 75_75	P71	BXN71MB4	142	
19.0	130	1.4	72	4830				WR 63_72	P71	BXN71MB4	138	
19.9	133	2.8	69	7000				WR 86_69	P71	BXN71MB4	146	
20.2	136	2.6	45	6200								
21.4	101	1.2	64	4870	W 63_64	S10	MXN10MB4	136	W 63_64	P71	BXN71MB4	138
21.4	112	2.5	64	7000	W 86_64	S10	MXN10MB4	144	W 86_64	P71	BXN71MB4	145
22.8	101	2.0	60	6200	W 75_60	S10	MXN10MB4	140	W 75_60	P71	BXN71MB4	141
22.8	119	2.5	60	6200				WR 75_60	P71	BXN71MB4	142	
22.8	119	3.2	60	7000				WR 86_60	P71	BXN71MB4	146	
24.0	107	1.7	57	4540				WR 63_57	P71	BXN71MB4	138	
24.5	101	3.0	56	7000	W 86_56	S10	MXN10MB4	144	W 86_56	P71	BXN71MB4	145
27.4	88	2.5	50	6200	W 75_50	S10	MXN10MB4	140	W 75_50	P71	BXN71MB4	141
30	73	0.9	45	2680				VF 49_45	P71	BXN71MB4	130	
30	78	1.9	45	4400	W 63_45	S10	MXN10MB4	136	W 63_45	P71	BXN71MB4	138
30	88	2.0	45	4250				WR 63_45	P71	BXN71MB4	138	
30	93	3.2	45	5880				WR 75_45	P71	BXN71MB4	142	
34	74	3.4	40	5820	W 75_40	S10	MXN10MB4	140	W 75_40	P71	BXN71MB4	141
36	69	2.3	38	4180	W 63_38	S10	MXN10MB4	136	W 63_38	P71	BXN71MB4	138
38	62	1.1	36	2530				VF 49_36	P71	BXN71MB4	130	
38	73	2.2	36	3980				WR 63_36	P71	BXN71MB4	138	
46	57	2.8	30	3900	W 63_30	S10	MXN10MB4	136	W 63_30	P71	BXN71MB4	138
49	51	1.4	28	2360				VF 49_28	P71	BXN71MB4	130	
57	46	1.4	24	2250				VF 49_24	P71	BXN71MB4	130	
57	48	3.2	24	3650	W 63_24	S10	MXN10MB4	136	W 63_24	P71	BXN71MB4	138
65	42	1.7	14	1940								
69	40	1.0	20	1870				VF 44_20	P71	BXN71MB4	124	
72	40	3.8	19	3400	W 63_19	S10	MXN10MB4	136	W 63_19	P71	BXN71MB4	138
76	36	1.6	18	2080				VF 49_18	P71	BXN71MB4	130	
79	33	0.9	35	1860								
91	32	2.0	10	1930								
98	29	1.0	14	1690				VF 44_14	P71	BXN71MB4	124	
98	29	2.2	14	1940				VF 49_14	P71	BXN71MB4	130	
117	24	2.0	24	1880								
137	22	1.3	10	1520				VF 44_10	P71	BXN71MB4	124	
137	22	2.7	10	1750				VF 49_10	P71	BXN71MB4	130	
138	21	1.4	20	1570								
153	19	2.3	18	1720								
196	16	1.9	7	1360				VF 44_7	P71	BXN71MB4	124	
196	16	3.5	7	1570				VF 49_7	P71	BXN71MB4	130	
275	11	2.0	10	1260								
393	8	2.8	7	1120								

## 0.55 kW

n <sub>2</sub> min-1	M <sub>2</sub> Nm	S	i	R <sub>n2</sub> N	 IE1 IE2		 IE1 IE2				
0.29	4019	1.1	3200	19500			W/VF 86/185_3200	P80	BN80B6	174	
0.36	3946	1.1	2560	19500			W/VF 86/185_2560	P80	BN80B6	174	
0.43	2902	1.4	3200	19500			W/VF 86/185_3200	P80	BN80A4	BE80A4	174
0.47	3004	0.9	2944	16000			W/VF 86/150_2944	P80	BN80A4	BE80A4	166
0.50	3362	1.3	1840	19500			W/VF 86/185_1840	P80	BN80B6	174	
0.54	2805	1.5	2560	19500			W/VF 86/185_2560	P80	BN80A4	BE80A4	174
0.76	2642	1.0	1840	16000			W/VF 86/150_1840	P80	BN80A4	BE80A4	166
0.76	2364	1.8	1840	19500			W/VF 86/185_1840	P80	BN80A4	BE80A4	174

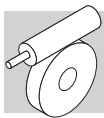

## 0.55 kW

n <sub>2</sub> min <sup>-1</sup>	M <sub>2</sub> Nm	S	i	Rn <sub>2</sub> N						
					IE1	IE2	IE1	IE2		
0.77	1905	0.9	1800	13800					W/VF 63/130_1800 P80 BN80A4 BE80A4	158
0.87	2116	2.0	1600	19500					W/VF 86/185_1600 P80 BN80A4 BE80A4	174
0.91	1838	1.0	1520	13800					W/VF 63/130_1520 P80 BN80A4 BE80A4	158
1.0	1996	2.2	920	19500					W/VF 86/185_920 P80 BN80B6	174
1.0	2190	1.2	1380	16000					W/VF 86/150_1380 P80 BN80A4 BE80A4	166
1.2	1542	1.2	1200	13800					W/VF 63/130_1200 P80 BN80A4 BE80A4	158
1.2	1542	2.7	1200	19500					W/VF 86/185_1200 P80 BN80A4 BE80A4	174
1.3	1852	1.5	690	16000					W/VF 86/150_690 P80 BN80B6	166
1.4	1342	1.3	960	13800					W/VF 63/130_960 P80 BN80A4 BE80A4	158
1.5	1564	1.7	920	16000					W/VF 86/150_920 P80 BN80A4 BE80A4	166
1.5	1460	2.9	920	19500					W/VF 86/185_920 P80 BN80A4 BE80A4	174
1.5	1473	3.0	600	19500					W/VF 86/185_600 P80 BN80B6	174
1.7	1300	3.2	800	19500					W/VF 86/185_800 P80 BN80A4 BE80A4	174
1.7	1570	1.7	529	16000					W/VF 86/150_529 P80 BN80B6	166
1.8	1120	1.6	760	13800					W/VF 63/130_760 P80 BN80A4 BE80A4	158
2.0	1304	2.0	690	16000					W/VF 86/150_690 P80 BN80A4 BE80A4	166
2.3	1028	1.0	400	8000					VF/W 49/110_400 P80 BN80B6	151
2.3	907	2.0	600	13800					W/VF 63/130_600 P80 BN80A4 BE80A4	158
2.6	837	1.2	540	8000					VF/W 49/110_540 P80 BN80A4 BE80A4	151
2.6	1099	2.4	529	16000					W/VF 86/150_529 P80 BN80A4 BE80A4	166
3.0	956	2.7	460	16000					W/VF 86/150_460 P80 BN80A4 BE80A4	166
3.1	839	1.2	300	13800					VFR 130_300 P80 BN80B6	154
3.1	805	1.3	300	8000					VF/W 49/110_300 P80 BN80B6	151
3.5	680	1.5	400	8000					VF/W 49/110_400 P80 BN80A4 BE80A4	151
3.5	665	2.7	400	13800					W/VF 63/130_400 P80 BN80A4 BE80A4	158
3.8	740	1.6	240	13800					VFR 130_240 P80 BN80B6	154
4.0	670	1.6	230	8000					VF/W 49/110_230 P80 BN80B6	151
4.0	756	3.4	345	16000					W/VF 86/150_345 P80 BN80A4 BE80A4	166
4.6	578	0.9	300	8000					WR 110_300 P80 BN80A4 BE80A4	150
4.6	601	1.5	300	13800					VFR 130_300 P80 BN80A4 BE80A4	154
4.6	544	1.8	300	8000					VF/W 49/110_300 P80 BN80A4 BE80A4	151
4.8	625	1.1	192	8000					WR 110_192 P80 BN80B6	150
5.0	529	3.4	280	13800					W/VF 63/130_280 P80 BN80A4 BE80A4	158
5.8	508	1.1	240	8000					WR 110_240 P80 BN80A4 BE80A4	150
5.8	517	2.2	240	13800					VFR 130_240 P80 BN80A4 BE80A4	154
6.0	452	2.2	230	8000					VF/W 49/110_230 P80 BN80A4 BE80A4	151
6.7	504	3.0	138	13800					VFR 130_138 P80 BN80B6	154
7.2	435	1.4	192	8000					WR 110_192 P80 BN80A4 BE80A4	150
7.2	443	2.7	192	13800					VFR 130_192 P80 BN80A4 BE80A4	154
7.7	432	1.0	120	7000					WR 86_120 P80 BN80B6	146
8.3	381	0.9	168	7000					WR 86_168 P80 BN80A4 BE80A4	146
8.3	400	1.8	168	8000					WR 110_168 P80 BN80A4 BE80A4	150
8.3	406	3.0	168	13800					VFR 130_168 P80 BN80A4 BE80A4	154
9.2	325	1.5	100	8000	W 110_100 S2	M2SA6		148	W 110_100 P80 BN80B6	149
10.1	329	1.2	138	7000					WR 86_138 P80 BN80A4 BE80A4	146
10.1	344	2.1	138	8000					WR 110_138 P80 BN80A4 BE80A4	150
10.2	344	1.1	90	6200					WR 75_90 P80 BN80B6	142
11.5	269	1.0	80	7000	W 86_80 S2	M2SA6		144	W 86_80 P80 BN80B6	145
11.6	286	1.1	120	6200					WR 75_120 P80 BN80A4 BE80A4	142
11.6	299	1.3	120	7000					WR 86_120 P80 BN80A4 BE80A4	146
11.6	308	2.6	120	8000					WR 110_120 P80 BN80A4 BE80A4	150
12.3	300	1.1	75	6200					WR 75_75 P80 BN80B6	142
13.3	288	1.4	69	7000					WR 86_69 P80 BN80B6	146
13.3	295	2.5	69	8000					WR 110_69 P80 BN80B6	150
13.8	225	1.0	100	7000	W 86_100 S1	M1LA4	ME2SA4	144	W 86_100 P80 BN80A4 BE80A4	145
15.4	235	1.4	90	6200					WR 75_90 P80 BN80A4 BE80A4	142
15.4	228	1.9	90	7000					WR 86_90 P80 BN80A4 BE80A4	146
15.4	238	3.5	90	8000					WR 110_90 P80 BN80A4 BE80A4	150
16.4	211	1.5	56	7000	W 86_56 S2	M2SA6		144	W 86_56 P80 BN80B6	145
17.3	180	1.0	80	6200	W 75_80 S1	M1LA4	ME2SA4	140	W 75_80 P80 BN80A4 BE80A4	141
17.3	195	1.3	80	7000	W 86_80 S1	M1LA4	ME2SA4	144	W 86_80 P80 BN80A4 BE80A4	145
18.5	207	1.4	75	6200					WR 75_75 P80 BN80A4 BE80A4	142
20.1	196	1.9	69	7000					WR 86_69 P80 BN80A4 BE80A4	146
20.1	201	3.2	69	8000					WR 110_69 P80 BN80A4 BE80A4	150
20.4	162	1.0	45	4540	W 63_45 S2	M2SA6		136	W 63_45 P80 BN80B6	138
21.6	166	1.7	64	7000	W 86_64 S1	M1LA4	ME2SA4	144	W 86_64 P80 BN80A4 BE80A4	145
23.0	148	1.3	60	6200	W 75_60 S1	M1LA4	ME2SA4	140	W 75_60 P80 BN80A4 BE80A4	141
23.0	162	2.2	40	7000	W 86_40 S2	M2SA6		144	W 86_40 P80 BN80B6	145
23.2	175	1.7	60	6040					WR 75_60 P80 BN80A4 BE80A4	142
23.2	175	2.2	60	7000					WR 86_60 P80 BN80A4 BE80A4	146
24.2	143	1.2	38	4340	W 63_38 S2	M2SA6		136	W 63_38 P80 BN80B6	138
24.6	149	2.0	56	7000	W 86_56 S1	M1LA4	ME2SA4	144	W 86_56 P80 BN80A4 BE80A4	145
27.6	129	1.7	50	5960	W 75_50 S1	M1LA4	ME2SA4	140	W 75_50 P80 BN80A4 BE80A4	141
30	128	2.7	46	7000	W 86_46 S1	M1LA4	ME2SA4	144	W 86_46 P80 BN80A4 BE80A4	145
31	115	1.3	45	4140	W 63_45 S1	M1LA4	ME2SA4	136	W 63_45 P80 BN80A4 BE80A4	138
31	136	2.2	45	5580					WR 75_45 P80 BN80A4 BE80A4	142

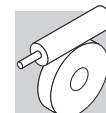

### 0.55 kW

n2 min-1	M2 Nm	S	i	Rn2 N	IE1		IE2		IEC					
									IE1	IE2				
31	133	2.9	45	7000					WR 86_45	P80	BN80A4	BE80A4	146	
35	110	2.3	40	5610	W 75_40	S1	M1LA4	ME2SA4	140	W 75_40	P80	BN80A4	BE80A4	141
35	114	2.9	40	7000	W 86_40	S1	M1LA4	ME2SA4	144	W 86_40	P80	BN80A4	BE80A4	145
36	101	1.5	38	3950	W 63_38	S1	M1LA4	ME2SA4	136	W 63_38	P80	BN80A4	BE80A4	138
40	105	3.3	23	7000	W 86_23	S2	M2SA6		144	W 86_23	P80	BN80B6		145
46	84	1.9	30	3700	W 63_30	S1	M1LA4	ME2SA4	136	W 63_30	P80	BN80A4	BE80A4	138
46	88	3.1	30	5150	W 75_30	S1	M1LA4	ME2SA4	140	W 75_30	P80	BN80A4	BE80A4	141
46	95	2.9	30	4950						WR 75_30	P80	BN80A4	BE80A4	142
49	76	1.0	28	2170						VF 49_28	P80	BN80A4	BE80A4	130
55	76	3.3	25	4880	W 75_25	S1	M1LA4	ME2SA4	140	W 75_25	P80	BN80A4	BE80A4	141
58	69	0.9	24	2080						VF 49_24	P80	BN80A4	BE80A4	130
58	71	2.2	24	3480	W 63_24	S1	M1LA4	ME2SA4	136	W 63_24	P80	BN80A4	BE80A4	138
66	62	1.1	14	1960						VF 49_14	P80	BN80B6		130
73	59	2.6	19	3260	W 63_19	S1	M1LA4	ME2SA4	136	W 63_19	P80	BN80A4	BE80A4	138
77	53	1.1	18	1930						VF 49_18	P80	BN80A4	BE80A4	130
92	47	1.4	10	1800						VF 49_10	P80	BN80B6		130
92	47	3.2	15	3050	W 63_15	S1	M1LA4	ME2SA4	136	W 63_15	P80	BN80A4	BE80A4	138
99	43	1.5	14	1810						VF 49_14	P80	BN80A4	BE80A4	130
115	39	3.6	12	2850	W 63_12	S1	M1LA4	ME2SA4	136	W 63_12	P80	BN80A4	BE80A4	138
117	35	1.3	24	1800						VF 49_24	P71	BN71B2		130
131	35	3.7	7	2700	W 63_7	S2	M2SA6		136	W 63_7	P80	BN80B6		138
138	32	1.8	10	1650						VF 49_10	P80	BN80A4	BE80A4	130
141	30	1.0	20	1490						VF 44_20	P71	BN71B2		124
156	28	1.6	18	1650						VF 49_18	P71	BN71B2		130
197	23	2.4	7	1480						VF 49_7	P80	BN80A4	BE80A4	130
281	16	1.4	10	1210						VF 44_10	P71	BN71B2		124
281	16	2.7	10	1390						VF 49_10	P71	BN71B2		130
401	12	1.9	7	1080						VF 44_7	P71	BN71B2		124

### 0.55 kW

n2 min-1	M2 Nm	S	i	Rn2 N	IE3			IEC					
								IE3	IE3				
0.29	4019	1.1	3200	19500									
0.36	3946	1.1	2560	19500									
0.43	2902	1.4	3200	19500	W/VF 86/185_3200	S20	MXN20MA4	174	W/VF 86/185_3200	P80	BXN80MA4	174	
0.47	3004	0.9	2944	16000	W/VF 86/150_2944	S20	MXN20MA4	166	W/VF 86/150_2944	P80	BXN80MA4	166	
0.50	3362	1.3	1840	19500									
0.54	2805	1.5	2560	19500	W/VF 86/185_2560	S20	MXN20MA4	174	W/VF 86/185_2560	P80	BXN80MA4	174	
0.76	2642	1.0	1840	16000	W/VF 86/150_1840	S20	MXN20MA4	166	W/VF 86/150_1840	P80	BXN80MA4	166	
0.76	2364	1.8	1840	19500	W/VF 86/185_1840	S20	MXN20MA4	174	W/VF 86/185_1840	P80	BXN80MA4	174	
0.77	1905	0.9	1800	13800	W/VF 63/130_1800	S20	MXN20MA4	158	W/VF 63/130_1800	P80	BXN80MA4	158	
0.87	2116	2.0	1600	19500	W/VF 86/185_1600	S20	MXN20MA4	174	W/VF 86/185_1600	P80	BXN80MA4	174	
0.91	1838	1.0	1520	13800	W/VF 63/130_1520	S20	MXN20MA4	158	W/VF 63/130_1520	P80	BXN80MA4	158	
1.0	1996	2.2	920	19500									
1.0	2190	1.2	1380	16000	W/VF 86/150_1380	S20	MXN20MA4	166	W/VF 86/150_1380	P80	BXN80MA4	166	
1.2	1542	1.2	1200	13800	W/VF 63/130_1200	S20	MXN20MA4	158	W/VF 63/130_1200	P80	BXN80MA4	158	
1.2	1542	2.7	1200	19500	W/VF 86/185_1200	S20	MXN20MA4	174	W/VF 86/185_1200	P80	BXN80MA4	174	
1.3	1852	1.5	690	16000									
1.4	1342	1.3	960	13800	W/VF 63/130_960	S20	MXN20MA4	158	W/VF 63/130_960	P80	BXN80MA4	158	
1.5	1564	1.7	920	16000	W/VF 86/150_920	S20	MXN20MA4	166	W/VF 86/150_920	P80	BXN80MA4	166	
1.5	1460	2.9	920	19500	W/VF 86/185_920	S20	MXN20MA4	174	W/VF 86/185_920	P80	BXN80MA4	174	
1.5	1473	3.0	600	19500									
1.7	1300	3.2	800	19500	W/VF 86/185_800	S20	MXN20MA4	174	W/VF 86/185_800	P80	BXN80MA4	174	
1.7	1570	1.7	529	16000									
1.8	1120	1.6	760	13800	W/VF 63/130_760	S20	MXN20MA4	158	W/VF 63/130_760	P80	BXN80MA4	158	
2.0	1304	2.0	690	16000	W/VF 86/150_690	S20	MXN20MA4	166	W/VF 86/150_690	P80	BXN80MA4	166	
2.3	1028	1.0	400	8000									
2.3	907	2.0	600	13800	W/VF 63/130_600	S20	MXN20MA4	158	W/VF 63/130_600	P80	BXN80MA4	158	
2.6	837	1.2	540	8000						VF/W 49/110_540	P80	BXN80MA4	151
2.6	1099	2.4	529	16000	W/VF 86/150_529	S20	MXN20MA4	166	W/VF 86/150_529	P80	BXN80MA4	166	
3.0	956	2.7	460	16000	W/VF 86/150_460	S20	MXN20MA4	166	W/VF 86/150_460	P80	BXN80MA4	166	
3.1	839	1.2	300	13800									
3.1	805	1.3	300	8000									
3.5	680	1.5	400	8000									
3.5	665	2.7	400	13800	W/VF 63/130_400	S20	MXN20MA4	158	VF/W 49/110_400	P80	BXN80MA4	151	
3.8	740	1.6	240	13800						W/VF 63/130_400	P80	BXN80MA4	158
4.0	670	1.6	230	8000									
4.0	756	3.4	345	16000	W/VF 86/150_345	S20	MXN20MA4	166	W/VF 86/150_345	P80	BXN80MA4	166	
4.6	578	0.9	300	8000						WR 110_300	P80	BXN80MA4	150
4.6	601	1.5	300	13800						VFR 130_300	P80	BXN80MA4	154







# 0.55 kW

n2 min-1	M2 Nm	S	i	Rn2 N	IE3			IEC	IE3			
4.6	544	1.8	300	8000					VF/W 49/110_300	P80	BXN80MA4	151
4.8	625	1.1	192	8000								
5.0	529	3.4	280	13800	W/VF 63/130_280	S20	MXN20MA4	158	W/VF 63/130_280	P80	BXN80MA4	158
5.8	508	1.1	240	8000					WR 110_240	P80	BXN80MA4	150
5.8	517	2.2	240	13800					VFR 130_240	P80	BXN80MA4	154
6.0	452	2.2	230	8000					VF/W 49/110_230	P80	BXN80MA4	151
6.7	504	3.0	138	13800								
7.2	435	1.4	192	8000					WR 110_192	P80	BXN80MA4	150
7.2	443	2.7	192	13800					VFR 130_192	P80	BXN80MA4	154
7.7	432	1.0	120	7000								
8.3	381	0.9	168	7000					WR 86_168	P80	BXN80MA4	146
8.3	400	1.8	168	8000					WR 110_168	P80	BXN80MA4	150
8.3	406	3.0	168	13800					VFR 130_168	P80	BXN80MA4	154
9.2	325	1.5	100	8000								
10.1	329	1.2	138	7000					WR 86_138	P80	BXN80MA4	146
10.1	344	2.1	138	8000					WR 110_138	P80	BXN80MA4	150
10.2	344	1.1	90	6200								
11.5	269	1.0	80	7000								
11.6	286	1.1	120	6200					WR 75_120	P80	BXN80MA4	142
11.6	299	1.3	120	7000					WR 86_120	P80	BXN80MA4	146
11.6	308	2.6	120	8000					WR 110_120	P80	BXN80MA4	150
12.3	300	1.1	75	6200								
13.3	288	1.4	69	7000								
13.3	295	2.5	69	8000								
13.8	225	1.0	100	7000	W 86_100	S20	MXN20MA4	144	W 86_100	P80	BXN80MA4	145
15.4	235	1.4	90	6200					WR 75_90	P80	BXN80MA4	142
15.4	228	1.9	90	7000					WR 86_90	P80	BXN80MA4	146
15.4	238	3.5	90	8000					WR 110_90	P80	BXN80MA4	150
16.4	211	1.5	56	7000								
17.3	180	1.0	80	6200	W 75_80	S20	MXN20MA4	140	W 75_80	P80	BXN80MA4	141
17.3	195	1.3	80	7000	W 86_80	S20	MXN20MA4	144	W 86_80	P80	BXN80MA4	145
18.5	207	1.4	75	6200					WR 75_75	P80	BXN80MA4	142
20.1	196	1.9	69	7000					WR 86_69	P80	BXN80MA4	146
20.1	201	3.2	69	8000					WR 110_69	P80	BXN80MA4	150
20.4	162	1.0	45	4540								
21.6	166	1.7	64	7000	W 86_64	S20	MXN20MA4	144	W 86_64	P80	BXN80MA4	145
23.0	148	1.3	60	6200	W 75_60	S20	MXN20MA4	140	W 75_60	P80	BXN80MA4	141
23.0	162	2.2	40	7000								
23.2	175	1.7	60	6040					WR 75_60	P80	BXN80MA4	142
23.2	175	2.2	60	7000					WR 86_60	P80	BXN80MA4	146
24.2	143	1.2	38	4340								
24.6	149	2.0	56	7000	W 86_56	S20	MXN20MA4	144	W 86_56	P80	BXN80MA4	145
27.6	129	1.7	50	5960	W 75_50	S20	MXN20MA4	140	W 75_50	P80	BXN80MA4	141
30	128	2.7	46	7000	W 86_46	S20	MXN20MA4	144	W 86_46	P80	BXN80MA4	145
31	115	1.3	45	4140	W 63_45	S20	MXN20MA4	136	W 63_45	P80	BXN80MA4	138
31	136	2.2	45	5580					WR 75_45	P80	BXN80MA4	142
31	133	2.9	45	7000					WR 86_45	P80	BXN80MA4	146
35	110	2.3	40	5610	W 75_40	S20	MXN20MA4	140	W 75_40	P80	BXN80MA4	141
35	114	2.9	40	7000	W 86_40	S20	MXN20MA4	144	W 86_40	P80	BXN80MA4	145
36	101	1.5	38	3950	W 63_38	S20	MXN20MA4	136	W 63_38	P80	BXN80MA4	138
40	105	3.3	23	7000								
46	84	1.9	30	3700	W 63_30	S20	MXN20MA4	136	W 63_30	P80	BXN80MA4	138
46	88	3.1	30	5150	W 75_30	S20	MXN20MA4	140	W 75_30	P80	BXN80MA4	141
46	95	2.9	30	4950					WR 75_30	P80	BXN80MA4	142
49	76	1.0	28	2170					VF 49_28	P80	BXN80MA4	130
55	76	3.3	25	4880	W 75_25	S20	MXN20MA4	140	W 75_25	P80	BXN80MA4	141
58	69	0.9	24	2080					VF 49_24	P80	BXN80MA4	130
58	71	2.2	24	3480	W 63_24	S20	MXN20MA4	136	W 63_24	P80	BXN80MA4	138
66	62	1.1	14	1960								
73	59	2.6	19	3260	W 63_19	S20	MXN20MA4	136	W 63_19	P80	BXN80MA4	138
77	53	1.1	18	1930					VF 49_18	P80	BXN80MA4	130
92	47	1.4	10	1800								
92	47	3.2	15	3050	W 63_15	S20	MXN20MA4	136	W 63_15	P80	BXN80MA4	138
99	43	1.5	14	1810					VF 49_14	P80	BXN80MA4	130
115	39	3.6	12	2850	W 63_12	S20	MXN20MA4	136	W 63_12	P80	BXN80MA4	138
117	35	1.3	24	1800								
131	35	3.7	7	2700								
138	32	1.8	10	1650					VF 49_10	P80	BXN80MA4	130
141	30	1.0	20	1490								
156	28	1.6	18	1650								
197	23	2.4	7	1480					VF 49_7	P80	BXN80MA4	130
281	16	1.4	10	1210								
281	16	2.7	10	1390								
401	12	1.9	7	1080								

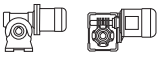

## 0.75 kW

n <sub>2</sub> min <sup>-1</sup>	M <sub>2</sub> Nm	S	i	R <sub>n2</sub> N	 IE2 IE3			 IE2 IE3						
0.29	4867	1.3	3200	34500				VF/NF 130/210_3200	P90	BE90S6		180		
0.29	4623	1.9	3200	52000				VF/NF 130/250_3200	P90	BE90S6		186		
0.37	4672	1.4	2560	34500				VF/NF 130/210_2560	P90	BE90S6		180		
0.37	4478	2.0	2560	52000				VF/NF 130/250_2560	P90	BE90S6		186		
0.45	3852	1.1	3200	19500				W /NF 86/185_3200	P80	BE80B4	BX80B4	174		
0.51	4478	1.0	1840	19500				W /NF 86/185_1840	P90	BE90S6		174		
0.51	3918	1.6	1840	34500				VF/NF 130/210_1840	P90	BE90S6		180		
0.51	4058	2.3	1840	52000				VF/NF 130/250_1840	P90	BE90S6		186		
0.56	3724	1.1	2560	19500				W /NF 86/185_2560	P80	BE80B4	BX80B4	174		
0.78	3138	1.3	1840	19500				W /NF 86/185_1840	P80	BE80B4	BX80B4	174		
0.90	2809	1.5	1600	19500				W /NF 86/185_1600	P80	BE80B4	BX80B4	174		
1.0	2659	1.6	920	19500				W /NF 86/185_920	P90	BE90S6		174		
1.2	2046	0.9	1200	13800				W /NF 63/130_1200	P80	BE80B4	BX80B4	158		
1.2	2046	2.0	1200	19500				W /NF 86/185_1200	P80	BE80B4	BX80B4	174		
1.4	2466	1.1	690	16000				W /NF 86/150_690	P90	BE90S6		166		
1.5	1781	1.0	960	13800				W /NF 63/130_960	P80	BE80B4	BX80B4	158		
1.5	2076	1.2	920	16000				W /NF 86/150_920	P80	BE80B4	BX80B4	166		
1.5	1938	2.1	920	19500				W /NF 86/185_920	P80	BE80B4	BX80B4	174		
1.8	2092	1.3	529	16000				W /NF 86/150_529	P90	BE90S6		166		
1.8	1725	2.4	800	19500				W /NF 86/185_800	P80	BE80B4	BX80B4	174		
1.8	1486	1.2	760	13800				W /NF 63/130_760	P80	BE80B4	BX80B4	158		
2.0	1730	1.5	690	16000				W /NF 86/150_690	P80	BE80B4	BX80B4	166		
2.3	1204	1.5	600	13800				W /NF 63/130_600	P80	BE80B4	BX80B4	158		
2.3	1354	3.1	600	19500				W /NF 86/185_600	P80	BE80B4	BX80B4	174		
2.7	1460	1.7	529	16000				W /NF 86/150_529	P80	BE80B4	BX80B4	166		
3.1	1269	2.0	460	16000				W /NF 86/150_460	P80	BE80B4	BX80B4	166		
3.1	1140	1.2	300	16000				VFR 150_300	P90	BE90S6		162		
3.1	1141	2.1	300	19500				VFR 185_300	P90	BE90S6		170		
3.6	903	1.1	400	8000				VF/W 49/110_400	P80	BE80B4	BX80B4	151		
3.6	882	2.0	400	13800				W /NF 63/130_400	P80	BE80B4	BX80B4	158		
3.9	986	1.2	240	13800				VFR 130_240	P90	BE90S6		154		
3.9	986	1.7	240	16000				VFR 150_240	P90	BE90S6		162		
3.9	986	2.9	240	19500				VFR 185_240	P90	BE90S6		170		
4.2	1004	2.6	345	16000				W /NF 86/150_345	P80	BE80B4	BX80B4	166		
4.8	797	1.1	300	13800				VFR 130_300	P80	BE80B4	BX80B4	154		
4.8	723	1.4	300	8000				VF/W 49/110_300	P80	BE80B4	BX80B4	151		
4.8	873	3.0	300	16000				W /NF 86/150_300	P80	BE80B4	BX80B4	166		
4.9	862	2.3	192	16000				VFR 150_192	P90	BE90S6		162		
5.1	702	2.6	280	13800				W /NF 63/130_280	P80	BE80B4	BX80B4	158		
5.6	767	1.0	168	8000				WR 110_168	P90	BE90S6		150		
5.6	661	1.2	168	16000				VFR 150_168	P90	BE90S6		162		
5.9	394	1.9	240	13800				VFR 130_240	P80	BE80B4	BX80B4	154		
6.2	267	1.3	230	8000				VF/W 49/110_230	P80	BE80B4	BX80B4	151		
6.8	661	1.2	138	8000				WR 110_138	P90	BE90S6		150		
6.8	672	2.3	138	13800				VFR 130_138	P90	BE90S6		154		
7.4	577	1.1	192	8000				WR 110_192	P80	BE80B4	BX80B4	150		
7.5	587	2.0	192	13800				VFR 130_192	P80	BE80B4	BX80B4	154		
8.5	530	1.3	168	8000				WR 110_168	P80	BE80B4	BX80B4	150		
8.5	539	2.2	168	13800				VFR 130_168	P80	BE80B4	BX80B4	154		
9.4	434	1.1	100	8000	W110_100	S3	ME3SA6	148	W 110_100	P90	BE90S6		149	
9.4	448	1.7	100	13200				VF 130_100	P90	BE90S6		152		
10.4	436	0.9	138	7000				WR 86_138	P80	BE80B4	BX80B4	146		
10.4	455	1.6	138	8000				WR 110_138	P80	BE80B4	BX80B4	150		
10.3	464	3.0	138	13800				VFR 130_138	P80	BE80B4	BX80B4	154		
11.8	372	1.4	80	8000	W110_80	S3	ME3SA6	148	W 110_80	P90	BE90S6		149	
11.8	390	2.5	80	13200				VF 130_80	P90	BE90S6		152		
12.0	397	1.0	120	7000				WR 86_120	P80	BE80B4	BX80B4	146		
12.0	409	1.9	120	8000				WR 110_120	P80	BE80B4	BX80B4	150		
12.0	403	3.5	120	13800				VFR 130_120	P80	BE80B4	BX80B4	154		
13.6	394	1.9	69	8000				WR 110_69	P90	BE90S6		150		
14.3	311	1.5	100	8000	W110_100	S2	ME2SB4	MX2SB4	148	W 110_100	P80	BE80B4	BX80B4	149
14.7	307	1.0	64	7000	W86_64	S3	ME3SA6	144	W 86_64	P90	BE90S6		145	
14.7	331	3.2	64	13200				VF 130_64	P90	BE90S6		152		
15.9	312	1.0	90	6200				WR 75_90	P80	BE80B4	BX80B4	142		
15.9	302	1.5	90	7000				WR 86_90	P80	BE80B4	BX80B4	146		
15.9	316	2.6	90	8000				WR 110_90	P80	BE80B4	BX80B4	150		
16.8	281	1.2	56	7000	W86_56	S3	ME3SA6	144	W 86_56	P90	BE90S6		145	
16.8	289	2.2	56	8000	W110_56	S3	ME3SA6	148	W 110_56	P90	BE90S6		149	
17.9	257	1.0	80	7000	W86_80	S2	ME2SB4	MX2SB4	144	W 86_80	P80	BE80B4	BX80B4	145
17.9	265	1.8	80	8000	W110_80	S2	ME2SB4	MX2SB4	148	W 110_80	P80	BE80B4	BX80B4	149
18.8	239	1.0	50	6200	W75_50	S3	ME3SA6	140	W 75_50	P90	BE90S6	BE90S6	141	
19.1	275	1.1	75	5980				WR 75_75	P80	BE80B4	BX80B4	142		

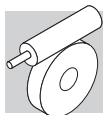

### 0.75 kW





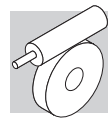

n <sub>2</sub> min <sup>-1</sup>	M <sub>2</sub> Nm	S	i	R <sub>n2</sub> N										
					IE2	IE3		IE2	IE3					
20.7	260	1.5	69	7000				WR 86_69	P80	BE80B4	BX80B4	146		
20.7	267	2.4	69	8000				WR 110_69	P80	BE80B4	BX80B4	150		
20.9	267	1.3	45	6010				WR 75_45	P90	BE90S6		142		
22.4	219	1.3	64	7000	W86_64	S2	ME2SB4	MX2SB4	144	W 86_64	P80	BE80B4	BX80B4	145
22.4	225	2.4	64	8000	W110_64	S2	ME2SB4	MX2SB4	148	W 110_64	P80	BE80B4	BX80B4	149
23.5	207	1.3	40	5930	W75_40	S3	ME3SA6		140	W 75_40	P90	BE90S6		141
23.8	196	1.0	60	5960	W75_60	S2	ME2SB4	MX2SB4	140	W 75_60	P80	BE80B4	BX80B4	141
23.8	231	1.3	60	5640				WR 75_60	P80	BE80B4	BX80B4	142		
23.8	231	1.6	60	7000				WR 86_60	P80	BE80B4	BX80B4	146		
23.8	238	2.8	60	8000				WR 110_60	P80	BE80B4	BX80B4	150		
25.5	197	1.5	56	7000	W86_56	S2	ME2SB4	MX2SB4	144	W 86_56	P80	BE80B4	BX80B4	145
25.5	202	3.0	56	8000	W110_56	S2	ME2SB4	MX2SB4	148	W 110_56	P80	BE80B4	BX80B4	149
28.6	171	1.3	50	5670	W75_50	S2	ME2SB4	MX2SB4	140	W 75_50	P80	BE80B4	BX80B4	141
30.6	169	2.0	46	7000	W86_46	S2	ME2SB4	MX2SB4	144	W 86_46	P80	BE80B4	BX80B4	145
30.6	171	3.5	46	8000	W110_46	S2	ME2SB4	MX2SB4	148	W 110_46	P80	BE80B4	BX80B4	149
32	151	1.0	45	3860	W63_45	S2	ME2SB4	MX2SB4	136	W 63_45	P80	BE80B4	BX80B4	138
32	180	1.6	45	5250				WR 75_45	P80	BE80B4	BX80B4	142		
32	176	2.2	45	7000				WR 86_45	P80	BE80B4	BX80B4	146		
36	144	1.8	40	5370	W75_40	S2	ME2SB4	MX2SB4	140	W 75_40	P80	BE80B4	BX80B4	141
36	150	2.2	40	7000	W86_40	S2	ME2SB4	MX2SB4	144	W 86_40	P80	BE80B4	BX80B4	145
38	133	1.2	38	3700	W63_38	S2	ME2SB4	MX2SB4	136	W 63_38	P80	BE80B4	BX80B4	138
41	140	2.5	23	7000	W86_23	S3	ME3SA6		144	W 86_23	P90	BE90S6		145
48	112	1.4	30	3490	W63_30	S2	ME2SB4	MX2SB4	136	W 63_30	P80	BE80B4	BX80B4	138
48	126	2.2	30	4680				WR 75_30	P80	BE80B4	BX80B4	142		
48	116	2.3	30	4950	W75_30	S2	ME2SB4	MX2SB4	140	W 75_30	P80	BE80B4	BX80B4	141
48	115	3.3	30	7000	W86_30	S2	ME2SB4	MX2SB4	144	W 86_30	P80	BE80B4	BX80B4	145
57	100	2.5	25	4700	W75_25	S2	ME2SB4	MX2SB4	140	W 75_25	P80	BE80B4	BX80B4	141
60	94	1.7	24	3290	W63_24	S2	ME2SB4	MX2SB4	136	W 63_24	P80	BE80B4	BX80B4	138
62	94	3.4	23	7000	W86_23	S2	ME2SB4	MX2SB4	144	W 86_23	P80	BE80B4	BX80B4	145
72	83	3.0	20	4400	W75_20	S2	ME2SB4	MX2SB4	140	W 75_20	P80	BE80B4	BX80B4	141
75	77	1.9	19	3100	W63_19	S2	ME2SB4	MX2SB4	136	W 63_19	P80	BE80B4	BX80B4	138
95	63	2.4	15	2910	W63_15	S2	ME2SB4	MX2SB4	136	W 63_15	P80	BE80B4	BX80B4	138
102	57	1.1	14	1690				VF 49_14	P80	BE80B4	BX80B4	130		
119	47	1.0	24	1710				VF 49_24	P80	BE80A2		130		
119	51	2.7	12	2740	W63_12	S2	ME2SB4	MX2SB4	136	W 63_12	P80	BE80B4	BX80B4	138
134	46	2.8	7	2590				W 63_7	P90	BE90S6		138		
143	42	1.4	10	1540				VF 49_10	P80	BE80B4	BX80B4	130		
143	43	3.3	10	2600	W63_10	S2	ME2SB4	MX2SB4	136	W 63_10	P80	BE80B4	BX80B4	138
190	32	3.9	15	2440	W 63_15	S2	ME2SA2		136	W 63_15	P80	BE80A2		138
204	30	1.8	7	1400				VF 49_7	P80	BE80B4	BX80B4	130		
204	31	3.9	7	2340	W63_7	S2	ME2SB4	MX2SB4	136	W 63_7	P80	BE80B4	BX80B4	138
285	21	2.1	10	1340				VF 49_10	P80	BE80A2		130		
407	15.5	2.7	7	1200				VF 49_7	P80	BE80A2		130		

### 0.75 kW

n <sub>2</sub> min <sup>-1</sup>	M <sub>2</sub> Nm	S	i	R <sub>n2</sub> N								
					IE3			IE3				
0.29	4867	1.3	3200	34500								
0.29	4623	1.9	3200	52000								
0.37	4672	1.4	2560	34500								
0.37	4478	2.0	2560	52000								
0.45	3852	1.1	3200	19500	W /VF 86/185_3200	S20	MXN20MB4	174	W /VF 86/185_3200	P80	BXN80MB4	174
0.51	4478	1.0	1840	19500								
0.51	3918	1.6	1840	34500								
0.51	4058	2.3	1840	52000								
0.56	3724	1.1	2560	19500	W /VF 86/185_2560	S20	MXN20MB4	174	W /VF 86/185_2560	P80	BXN80MB4	174
0.78	3138	1.3	1840	19500	W /VF 86/185_1840	S20	MXN20MB4	174	W /VF 86/185_1840	P80	BXN80MB4	174
0.90	2809	1.5	1600	19500	W /VF 86/185_1600	S20	MXN20MB4	174	W /VF 86/185_1600	P80	BXN80MB4	174
1.0	2659	1.6	920	19500								
1.2	2046	0.9	1200	13800	W /VF 63/130_1200	S20	MXN20MB4	158	W /VF 63/130_1200	P80	BXN80MB4	158
1.2	2046	2.0	1200	19500	W /VF 86/185_1200	S20	MXN20MB4	174	W /VF 86/185_1200	P80	BXN80MB4	174
1.4	2466	1.1	690	16000								
1.5	1781	1.0	960	13800	W /VF 63/130_960	S20	MXN20MB4	158	W /VF 63/130_960	P80	BXN80MB4	158
1.5	2076	1.2	920	16000	W /VF 86/150_920	S20	MXN20MB4	166	W /VF 86/150_920	P80	BXN80MB4	166
1.5	1938	2.1	920	19500	W /VF 86/185_920	S20	MXN20MB4	174	W /VF 86/185_920	P80	BXN80MB4	174
1.8	2092	1.3	529	16000								











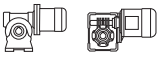

# 0.75 kW











n2 min-1	M2 Nm	S	i	Rn2 N	IE3			IEC				
												
1.8	1725	2.4	800	19500	W /VF 86/185_800	S20	MXN20MB4	174	W /VF 86/185_800	P80	BXN80MB4	174
1.8	1486	1.2	760	13800	W /VF 63/130_760	S20	MXN20MB4	158	W /VF 63/130_760	P80	BXN80MB4	158
2.0	1730	1.5	690	16000	W /VF 86/150_690	S20	MXN20MB4	166	W /VF 86/150_690	P80	BXN80MB4	166
2.3	1204	1.5	600	13800	W /VF 63/130_600	S20	MXN20MB4	158	W /VF 63/130_600	P80	BXN80MB4	158
2.3	1354	3.1	600	19500	W /VF 86/185_600	S20	MXN20MB4	174	W /VF 86/185_600	P80	BXN80MB4	174
2.7	1460	1.7	529	16000	W /VF 86/150_529	S20	MXN20MB4	166	W /VF 86/150_529	P80	BXN80MB4	166
3.1	1269	2.0	460	16000	W /VF 86/150_460	S20	MXN20MB4	166	W /VF 86/150_460	P80	BXN80MB4	166
3.1	1140	1.2	300	16000								
3.1	1141	2.1	300	19500								
3.6	903	1.1	400	8000					VF/W 49/110_400	P80	BXN80MB4	151
3.6	882	2.0	400	13800	W /VF 63/130_400	S20	MXN20MB4	158	W /VF 63/130_400	P80	BXN80MB4	158
3.9	986	1.2	240	13800								
3.9	986	1.7	240	16000								
3.9	986	2.9	240	19500								
4.2	1004	2.6	345	16000	W /VF 86/150_345	S20	MXN20MB4	166	W /VF 86/150_345	P80	BXN80MB4	166
4.8	797	1.1	300	13800					VFR 130_300	P80	BXN80MB4	154
4.8	723	1.4	300	8000					VF/W 49/110_300	P80	BXN80MB4	151
4.8	873	3.0	300	16000	W /VF 86/150_300	S20	MXN20MB4	166	W /VF 86/150_300	P80	BXN80MB4	166
4.9	862	2.3	192	16000								
5.1	702	2.6	280	13800	W /VF 63/130_280	S20	MXN20MB4	158	W /VF 63/130_280	P80	BXN80MB4	158
5.6	767	1.0	168	8000								
5.6	661	1.2	168	16000					VFR 130_240	P80	BXN80MB4	154
5.9	394	1.9	240	13800					VF/W 49/110_230	P80	BXN80MB4	151
6.2	267	1.3	230	8000								
6.8	661	1.2	138	8000								
6.8	672	2.3	138	13800								
7.4	577	1.1	192	8000					WR 110_192	P80	BXN80MB4	150
7.5	587	2.0	192	13800					VFR 130_192	P80	BXN80MB4	154
8.5	530	1.3	168	8000					WR 110_168	P80	BXN80MB4	150
8.5	539	2.2	168	13800					VFR 130_168	P80	BXN80MB4	154
9.4	434	1.1	100	8000								
9.4	448	1.7	100	13200								
10.4	436	0.9	138	7000					WR 86_138	P80	BXN80MB4	146
10.4	455	1.6	138	8000					WR 110_138	P80	BXN80MB4	150
10.3	464	3.0	138	13800					VFR 130_138	P80	BXN80MB4	154
11.8	372	1.4	80	8000								
11.8	390	2.5	80	13200								
12.0	397	1.0	120	7000					WR 86_120	P80	BXN80MB4	146
12.0	409	1.9	120	8000					WR 110_120	P80	BXN80MB4	150
12.0	403	3.5	120	13800					VFR 130_120	P80	BXN80MB4	154
13.6	394	1.9	69	8000								
14.3	311	1.5	100	8000					W 110_100	P80	BXN80MB4	149
14.7	307	1.0	64	7000								
14.7	331	3.2	64	13200								
15.9	312	1.0	90	6200					WR 75_90	P80	BXN80MB4	142
15.9	302	1.5	90	7000					WR 86_90	P80	BXN80MB4	146
15.9	316	2.6	90	8000					WR 110_90	P80	BXN80MB4	150
16.8	281	1.2	56	7000								
16.8	289	2.2	56	8000								
17.9	257	1.0	80	7000	W86_80	S20	MXN20MB4	144	W 86_80	P80	BXN80MB4	145
17.9	265	1.8	80	8000					W 110_80	P80	BXN80MB4	149
18.8	239	1.0	50	6200								
19.1	275	1.1	75	5980					WR 75_75	P80	BXN80MB4	142
20.7	260	1.5	69	7000					WR 86_69	P80	BXN80MB4	146
20.7	267	2.4	69	8000					WR 110_69	P80	BXN80MB4	150
20.9	267	1.3	45	6010								
22.4	219	1.3	64	7000	W86_64	S20	MXN20MB4	144	W 86_64	P80	BXN80MB4	145
22.4	225	2.4	64	8000					W 110_64	P80	BXN80MB4	149
23.5	207	1.3	40	5930								
23.8	196	1.0	60	5960	W75_60	S20	MXN20MB4	140	W 75_60	P80	BXN80MB4	141
23.8	231	1.3	60	5640					WR 75_60	P80	BXN80MB4	142
23.8	231	1.6	60	7000					WR 86_60	P80	BXN80MB4	146
23.8	238	2.8	60	8000					WR 110_60	P80	BXN80MB4	150
25.5	197	1.5	56	7000	W86_56	S20	MXN20MB4	144	W 86_56	P80	BXN80MB4	145
25.5	202	3.0	56	8000					W 110_56	P80	BXN80MB4	149
28.6	171	1.3	50	5670	W75_50	S20	MXN20MB4	140	W 75_50	P80	BXN80MB4	141
30.6	169	2.0	46	7000	W86_46	S20	MXN20MB4	144	W 86_46	P80	BXN80MB4	145
30.6	171	3.5	46	8000					W 110_46	P80	BXN80MB4	149
32	151	1.0	45	3860	W63_45	S20	MXN20MB4	136	W 63_45	P80	BXN80MB4	138
32	180	1.6	45	5250					WR 75_45	P80	BXN80MB4	142
32	176	2.2	45	7000					WR 86_45	P80	BXN80MB4	146
36	144	1.8	40	5370	W75_40	S20	MXN20MB4	140	W 75_40	P80	BXN80MB4	141



## 0.75 kW

n <sub>2</sub> min-1	M <sub>2</sub> Nm	S	i	R <sub>n2</sub> N	 IE3				 IEC  IE3			
												
36	150	2.2	40	7000	W86_40	S20	MXN20MB4	144	W 86_40	P80	BXN80MB4	145
38	133	1.2	38	3700	W63_38	S20	MXN20MB4	136	W 63_38	P80	BXN80MB4	138
41	140	2.5	23	7000								
48	112	1.4	30	3490	W63_30	S20	MXN20MB4	136	W 63_30	P80	BXN80MB4	138
48	126	2.2	30	4680				WR 75_30	P80	BXN80MB4	142	
48	116	2.3	30	4950	W75_30	S20	MXN20MB4	140	W 75_30	P80	BXN80MB4	141
48	115	3.3	30	7000	W86_30	S20	MXN20MB4	144	W 86_30	P80	BXN80MB4	145
57	100	2.5	25	4700	W75_25	S20	MXN20MB4	140	W 75_25	P80	BXN80MB4	141
60	94	1.7	24	3290	W63_24	S20	MXN20MB4	136	W 63_24	P80	BXN80MB4	138
62	94	3.4	23	7000	W86_23	S20	MXN20MB4	144	W 86_23	P80	BXN80MB4	145
72	83	3.0	20	4400	W75_20	S20	MXN20MB4	140	W 75_20	P80	BXN80MB4	141
75	77	1.9	19	3100	W63_19	S20	MXN20MB4	136	W 63_19	P80	BXN80MB4	138
95	63	2.4	15	2910	W63_15	S20	MXN20MB4	136	W 63_15	P80	BXN80MB4	138
102	57	1.1	14	1690				VF 49_14	P80	BXN80MB4	130	
119	47	1.0	24	1710								
119	51	2.7	12	2740	W63_12	S20	MXN20MB4	136	W 63_12	P80	BXN80MB4	138
134	46	2.8	7	2590								
143	42	1.4	10	1540				VF 49_10	P80	BXN80MB4	130	
143	43	3.3	10	2600	W63_10	S20	MXN20MB4	136	W 63_10	P80	BXN80MB4	138
190	32	3.9	15	2440								
204	30	1.8	7	1400				VF 49_7	P80	BXN80MB4	130	
204	31	3.9	7	2340	W63_7	S20	MXN20MB4	136	W 63_7	P80	BXN80MB4	138
285	21	2.1	10	1340								
407	15.5	2.7	7	1200								





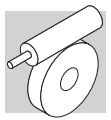

## 1.1 kW

n <sub>2</sub> min-1	M <sub>2</sub> Nm	S	i	R <sub>n2</sub> N	 IE2  IE3			 IEC  IE3				
												
0.30	7126	0.9	3200	34500				VF/VF 130/210_3200	P100	BE100M6	180	
0.30	6769	1.3	3200	52000				VF/VF 130/250_3200	P100	BE100M6	186	
0.37	6841	0.9	2560	34500				VF/VF 130/210_2560	P100	BE100M6	180	
0.37	6555	1.4	2560	52000				VF/VF 130/250_2560	P100	BE100M6	186	
0.45	5213	1.2	3200	34500				VF/VF 130/210_3200	P90	BE90S4	BX90S4	180
0.45	4975	1.8	3200	52000				VF/VF 130/250_3200	P90	BE90S4	BX90S4	186
0.51	6965	0.9	1840	34500				VF/VF 130/210_1840	P100	BE100M6	180	
0.51	5941	1.5	1840	52000				VF/VF 130/250_1840	P100	BE100M6	186	
0.56	4549	1.4	2560	34500				VF/VF 130/210_2560	P90	BE90S4	BX90S4	180
0.56	4738	1.9	2560	52000				VF/VF 130/250_2560	P90	BE90S4	BX90S4	186
0.78	4631	0.9	1840	19500				W /VF 86/185_1840	P90	BE90S4	BX90S4	174
0.78	4768	1.3	1840	34500				VF/VF 130/210_1840	P90	BE90S4	BX90S4	180
0.78	4223	2.1	1840	52000				VF/VF 130/250_1840	P90	BE90S4	BX90S4	186
0.90	4146	1.0	1600	19500				W /VF 86/185_1600	P90	BE90S4	BX90S4	174
1.0	3892	1.1	920	19500				W /VF 86/185_920	P100	BE100M6	174	
1.2	3020	1.4	1200	19500				W /VF 86/185_1200	P90	BE90S4	BX90S4	174
1.5	2860	1.4	920	19500				W /VF 86/185_920	P90	BE90S4	BX90S4	174
1.8	2547	1.6	800	19500				W /VF 86/185_800	P90	BE90S4	BX90S4	174
2.0	2554	1.0	690	16000				W /VF 86/150_690	P90	BE90S4	BX90S4	166
2.3	1777	1.0	600	13800				W /VF 63/130_600	P90	BE90S4	BX90S4	158
2.3	1999	2.1	600	19500				W /VF 86/185_600	P90	BE90S4	BX90S4	174
2.7	2154	1.2	529	16000				W /VF 86/150_529	P90	BE90S4	BX90S4	166
3.1	1873	1.4	460	16000				W /VF 86/150_460	P90	BE90S4	BX90S4	166
3.2	1670	1.4	300	19500				VFR 185_300	P100	BE100M6	170	
3.6	1303	1.4	400	13800				W /VF 63/130_400	P90	BE90S4	BX90S4	158
3.6	1422	2.9	400	19500				W /VF 86/185_400	P90	BE90S4	BX90S4	174
3.9	1443	1.1	240	16000				VFR 150_240	P100	BE100M6	162	
3.9	1443	1.9	240	19500				VFR 185_240	P100	BE100M6	170	
4.2	1481	1.7	345	16000				W /VF 86/150_345	P90	BE90S4	BX90S4	166
4.8	1206	1.1	300	16000				VFR 150_300	P90	BE90S4	BX90S4	162
4.8	1221	1.9	300	19500				VFR 185_300	P90	BE90S4	BX90S4	170
4.8	1289	2.0	300	16000				W /VF 86/150_300	P90	BE90S4	BX90S4	166
4.9	1240	1.0	192	13800				VFR 130_192	P100	BE100M6	154	
5.1	1037	1.7	280	13800				W /VF 63/130_280	P90	BE90S4	BX90S4	158
5.9	1012	1.1	240	13800				VFR 130_240	P90	BE90S4	BX90S4	154
5.9	1030	1.5	240	16000				VFR 150_240	P90	BE90S4	BX90S4	162
5.9	1049	2.6	240	19500				VFR 185_240	P90	BE90S4	BX90S4	170
6.3	1050	2.4	225	16000				W /VF 86/150_225	P90	BE90S4	BX90S4	166





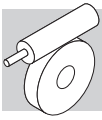

## 1.1 kW

n <sub>2</sub> min <sup>-1</sup>	M <sub>2</sub> Nm	S	i	R <sub>n2</sub> N	 				  					
					IE2	IE3	IE2		IE3					
6.8	983	1.5	138	13800				VFR 130_138	P100	BE100M6		154		
6.8	983	2.3	138	16000				VFR 150_138	P100	BE100M6		162		
7.2	947	2.7	200	16000				W /VF 86/150_200	P90	BE90S4	BX90S4	166		
7.5	867	1.4	192	13800				VFR 130_192	P90	BE90S4	BX90S4	154		
7.5	881	1.9	192	16000				VFR 150_192	P90	BE90S4	BX90S4	162		
7.9	869	1.0	120	8000				WR 110_120	P100	BE100M6		150		
8.0	866	3.4	180	19500				VFR 185_180	P90	BE90S4	BX90S4	170		
8.5	796	1.5	168	13800				VFR 130_168	P90	BE90S4	BX90S4	154		
8.5	808	2.1	168	16000				VFR 150_168	P90	BE90S4	BX90S4	162		
9.5	657	1.2	100	13200				VF 130_100	P100	BE100M6		152		
10.3	674	1.1	138	8000				WR 110_138	P90	BE90S4	BX90S4	150		
10.3	685	1.9	138	13800				VFR 130_138	P90	BE90S4	BX90S4	154		
10.3	695	2.8	138	16000				VFR 150_138	P90	BE90S4	BX90S4	162		
10.5	661	1.4	90	8000				WR 110_90	P100	BE100M6		150		
11.8	570	1.6	80	13200				VF 130_80	P100	BE100M6		152		
12.0	604	1.3	120	8000				WR 110_120	P90	BE90S4	BX90S4	150		
12.0	595	2.3	120	13800				VFR 130_120	P90	BE90S4	BX90S4	154		
12.0	604	3.3	120	16000				VFR 150_120	P90	BE90S4	BX90S4	162		
14.3	459	1.0	100	8000	W110_100	S3	ME3SA4	MX3SA4	148	W 110_100	P90	BE90S4	BX90S4	149
14.3	518	1.1	100	12600				VF 130_100	P90	BE90S4	BX90S4	152		
15.9	467	1.8	90	8000				WR 110_90	P90	BE90S4	BX90S4	150		
15.9	473	3.1	90	13800				VFR 130_90	P90	BE90S4	BX90S4	154		
17.9	391	1.2	80	8000	W110_80	S3	ME3SA4	MX3SA4	148	W 110_80	P90	BE90S4	BX90S4	149
17.9	403	2.2	80	12600				VF 130_80	P90	BE90S4	BX90S4	152		
20.5	353	1.0	46	7000	W86_46	S3	ME3LA6		144	W 86_46	P100	BE100M6		145
20.5	373	3.1	46	13200				VF 130_46	P100	BE100M6		152		
20.7	383	1.0	69	7000				WR 86_69	P90	BE90S4	BX90S4	146		
20.7	394	1.6	69	8000				WR 110_69	P90	BE90S4	BX90S4	150		
20.7	388	3.3	69	13800				VFR 130_69	P90	BE90S4	BX90S4	154		
22.4	332	1.6	64	8000	W110_64	S3	ME3SA4	MX3SA4	148	W 110_64	P90	BE90S4	BX90S4	149
22.4	336	2.7	64	12600				VF 130_64	P90	BE90S4	BX90S4	152		
23.6	316	1.1	40	7000	W86_40	S3	ME3LA6		144	W 86_40	P100	BE100M6		145
23.8	342	1.1	60	7000				WR 86_60	P90	BE90S4	BX90S4	146		
23.8	351	1.9	60	8000				WR 110_60	P90	BE90S4	BX90S4	150		
25.5	290	1.0	56	7000	W86_56	S3	ME3SA4	MX3SA4	144	W 86_56	P90	BE90S4	BX90S4	145
25.5	299	2.0	56	8000	W110_56	S3	ME3SA4	MX3SA4	148	W 110_56	P90	BE90S4	BX90S4	149
25.5	303	3.1	56	12600				VF 130_56	P90	BE90S4	BX90S4	152		
31	249	1.4	46	7000	W86_46	S3	ME3SA4	MX3SA4	144	W 86_46	P90	BE90S4	BX90S4	145
31	252	2.4	46	8000	W110_46	S3	ME3SA4	MX3SA4	148	W 110_46	P90	BE90S4	BX90S4	149
32	266	1.1	45	5010				WR 75_45	P90	BE90S4	BX90S4	142		
32	259	1.5	45	7000				WR 86_45	P90	BE90S4	BX90S4	146		
32	266	2.7	45	8000				WR 110_45	P90	BE90S4	BX90S4	150		
36	213	1.2	40	4980	W75_40	S3	ME3SA4	MX3SA4	140	W 75_40	P90	BE90S4	BX90S4	141
36	222	1.5	40	7000	W86_40	S3	ME3SA4	MX3SA4	144	W 86_40	P90	BE90S4	BX90S4	145
36	225	3.0	40	8000	W110_40	S3	ME3SA4	MX3SA4	148	W 110_40	P90	BE90S4	BX90S4	149
38	214	1.3	38	4790				WR 75_37.5	P90	BE90S4	BX90S4	142		
41	205	1.6	23	7000	W86_23	S3	ME3LA6		144	W 86_23	P100	BE100M6		145
41	204	1.7	35	7000				WR 86_34.5	P90	BE90S4	BX90S4	146		
48	165	1.0	30	3130				W 63_30	P90	BE90S4	BX90S4	138		
48	186	1.5	30	4530				WR 75_30	P90	BE90S4	BX90S4	142		
48	171	1.6	30	4640	W75_30	S3	ME3SA4	MX3SA4	140	W 75_30	P90	BE90S4	BX90S4	141
48	183	1.9	30	7000				WR 86_30	P90	BE90S4	BX90S4	146		
48	169	2.2	30	7000	W86_30	S3	ME3SA4	MX3SA4	144	W 86_30	P90	BE90S4	BX90S4	145
57	148	1.7	25	4420	W75_25	S3	ME3SA4	MX3SA4	140	W 75_25	P90	BE90S4	BX90S4	141
59	138	1.1	24	2990				W 63_24	P90	BE90S4	BX90S4	138		
62	140	2.3	23	7000	W86_23	S3	ME3SA4	MX3SA4	144	W 86_23	P90	BE90S4	BX90S4	145
72	123	2.0	20	4160	W75_20	S3	ME3SA4	MX3SA4	140	W 75_20	P90	BE90S4	BX90S4	141
72	124	2.6	20	7000	W86_20	S3	ME3SA4	MX3SA4	144	W 86_20	P90	BE90S4	BX90S4	145
76	113	1.3	19	2840				W 63_19	P90	BE90S4	BX90S4	138		
95	92	1.6	15	2690				W 63_15	P90	BE90S4	BX90S4	138		
95	95	2.6	15	3850	W75_15	S3	ME3SA4	MX3SA4	140	W 75_15	P90	BE90S4	BX90S4	141
95	95	3.4	15	6820	W86_15	S3	ME3SA4	MX3SA4	144	W 86_15	P90	BE90S4	BX90S4	145
119	75	1.9	12	2550				W 63_12	P90	BE90S4	BX90S4	138		
143	64	2.2	10	2440				W 63_10	P90	BE90S4	BX90S4	138		
143	65	3.5	10	3420	W75_10	S3	ME3SA4	MX3SA4	140	W 75_10	P90	BE90S4	BX90S4	141
189	47	2.6	15	2330	W63_15	S2	ME2SB2		136	W 63_15	P80	BE80B2		138
204	45	2.6	7	2210				W 63_7	P90	BE90S4	BX90S4	138		
236	38	3.3	12	2190	W63_12	S2	ME2SB2		136	W 63_12	P80	BE80B2		138
283	32	3.9	10	2080	W63_10	S2	ME2SB2		136	W 63_10	P80	BE80B2		138

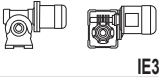

## 1.1 kW

n <sub>2</sub> min <sup>-1</sup>	M <sub>2</sub> Nm	S	i	Rn <sub>2</sub> N	 IE3		 IEC		
					VF/VF	W/VF	P90	BXN90S4	
0.30	7126	0.9	3200	34500					
0.30	6769	1.3	3200	52000					
0.37	6841	0.9	2560	34500					
0.37	6555	1.4	2560	52000					
0.45	5213	1.2	3200	34500			VF/VF 130/210_3200	P90 BXN90S4	180
0.45	4975	1.8	3200	52000			VF/VF 130/250_3200	P90 BXN90S4	186
0.51	6965	0.9	1840	34500					
0.51	5941	1.5	1840	52000					
0.56	4549	1.4	2560	34500			VF/VF 130/210_2560	P90 BXN90S4	180
0.56	4738	1.9	2560	52000			VF/VF 130/250_2560	P90 BXN90S4	186
0.78	4631	0.9	1840	19500			W/VF 86/185_1840	P90 BXN90S4	174
0.78	4768	1.3	1840	34500			VF/VF 130/210_1840	P90 BXN90S4	180
0.78	4223	2.1	1840	52000			VF/VF 130/250_1840	P90 BXN90S4	186
0.90	4146	1.0	1600	19500			W/VF 86/185_1600	P90 BXN90S4	174
1.0	3892	1.1	920	19500					
1.2	3020	1.4	1200	19500			W/VF 86/185_1200	P90 BXN90S4	174
1.5	2860	1.4	920	19500			W/VF 86/185_920	P90 BXN90S4	174
1.8	2547	1.6	800	19500			W/VF 86/185_800	P90 BXN90S4	174
2.0	2554	1.0	690	16000			W/VF 86/150_690	P90 BXN90S4	166
2.3	1777	1.0	600	13800			W/VF 63/130_600	P90 BXN90S4	158
2.3	1999	2.1	600	19500			W/VF 86/185_600	P90 BXN90S4	174
2.7	2154	1.2	529	16000			W/VF 86/150_529	P90 BXN90S4	166
3.1	1873	1.4	460	16000			W/VF 86/150_460	P90 BXN90S4	166
3.2	1670	1.4	300	19500					
3.6	1303	1.4	400	13800			W/VF 63/130_400	P90 BXN90S4	158
3.6	1422	2.9	400	19500			W/VF 86/185_400	P90 BXN90S4	174
3.9	1443	1.1	240	16000					
3.9	1443	1.9	240	19500					
4.2	1481	1.7	345	16000			W/VF 86/150_345	P90 BXN90S4	166
4.8	1206	1.1	300	16000			VFR 150_300	P90 BXN90S4	162
4.8	1221	1.9	300	19500			VFR 185_300	P90 BXN90S4	170
4.8	1289	2.0	300	16000			W/VF 86/150_300	P90 BXN90S4	166
4.9	1240	1.0	192	13800					
5.1	1037	1.7	280	13800			W/VF 63/130_280	P90 BXN90S4	158
5.9	1012	1.1	240	13800			VFR 130_240	P90 BXN90S4	154
5.9	1030	1.5	240	16000			VFR 150_240	P90 BXN90S4	162
5.9	1049	2.6	240	19500			VFR 185_240	P90 BXN90S4	170
6.3	1050	2.4	225	16000			W/VF 86/150_225	P90 BXN90S4	166
6.8	983	1.5	138	13800					
6.8	983	2.3	138	16000					
7.2	947	2.7	200	16000			W/VF 86/150_200	P90 BXN90S4	166
7.5	867	1.4	192	13800			VFR 130_192	P90 BXN90S4	154
7.5	881	1.9	192	16000			VFR 150_192	P90 BXN90S4	162
7.9	869	1.0	120	8000					
8.0	866	3.4	180	19500			VFR 185_180	P90 BXN90S4	170
8.5	796	1.5	168	13800			VFR 130_168	P90 BXN90S4	154
8.5	808	2.1	168	16000			VFR 150_168	P90 BXN90S4	162
9.5	657	1.2	100	13200					
10.3	674	1.1	138	8000			WR 110_138	P90 BXN90S4	150
10.3	685	1.9	138	13800			VFR 130_138	P90 BXN90S4	154
10.3	695	2.8	138	16000			VFR 150_138	P90 BXN90S4	162
10.5	661	1.4	90	8000					
11.8	570	1.6	80	13200					
12.0	604	1.3	120	8000			WR 110_120	P90 BXN90S4	150
12.0	595	2.3	120	13800			VFR 130_120	P90 BXN90S4	154
12.0	604	3.3	120	16000			VFR 150_120	P90 BXN90S4	162
14.3	459	1.0	100	8000			W 110_100	P90 BXN90S4	149
14.3	518	1.1	100	12600			VF 130_100	P90 BXN90S4	152
15.9	467	1.8	90	8000			WR 110_90	P90 BXN90S4	150
15.9	473	3.1	90	13800			VFR 130_90	P90 BXN90S4	154
17.9	391	1.2	80	8000			W 110_80	P90 BXN90S4	149
17.9	403	2.2	80	12600			VF 130_80	P90 BXN90S4	152
20.5	353	1.0	46	7000					
20.5	373	3.1	46	13200					
20.7	383	1.0	69	7000			WR 86_69	P90 BXN90S4	146
20.7	394	1.6	69	8000			WR 110_69	P90 BXN90S4	150
20.7	388	3.3	69	13800			VFR 130_69	P90 BXN90S4	154
22.4	332	1.6	64	8000			W 110_64	P90 BXN90S4	149
22.4	336	2.7	64	12600			VF 130_64	P90 BXN90S4	152
23.6	316	1.1	40	7000					

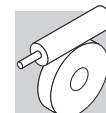

## 1.1 kW







n <sub>2</sub> min <sup>-1</sup>	M <sub>2</sub> Nm	S	i	R <sub>n2</sub> N	 IE3		 IEC			
23.8	342	1.1	60	7000			WR 86_60	P90	BXN90S4	146
23.8	351	1.9	60	8000			WR 110_60	P90	BXN90S4	150
25.5	290	1.0	56	7000			W 86_56	P90	BXN90S4	145
25.5	299	2.0	56	8000			W 110_56	P90	BXN90S4	149
25.5	303	3.1	56	12600			VF 130_56	P90	BXN90S4	152
31	249	1.4	46	7000			W 86_46	P90	BXN90S4	145
31	252	2.4	46	8000			W 110_46	P90	BXN90S4	149
32	266	1.1	45	5010			WR 75_45	P90	BXN90S4	142
32	259	1.5	45	7000			WR 86_45	P90	BXN90S4	146
32	266	2.7	45	8000			WR 110_45	P90	BXN90S4	150
36	213	1.2	40	4980			W 75_40	P90	BXN90S4	141
36	222	1.5	40	7000			W 86_40	P90	BXN90S4	145
36	225	3.0	40	8000			W 110_40	P90	BXN90S4	149
38	214	1.3	38	4790			WR 75_37.5	P90	BXN90S4	142
41	205	1.6	23	7000						
41	204	1.7	35	7000			WR 86_34.5	P90	BXN90S4	146
48	165	1.0	30	3130			W 63_30	P90	BXN90S4	138
48	186	1.5	30	4530			WR 75_30	P90	BXN90S4	142
48	171	1.6	30	4640			W 75_30	P90	BXN90S4	141
48	183	1.9	30	7000			WR 86_30	P90	BXN90S4	146
48	169	2.2	30	7000			W 86_30	P90	BXN90S4	145
57	148	1.7	25	4420			W 75_25	P90	BXN90S4	141
59	138	1.1	24	2990			W 63_24	P90	BXN90S4	138
62	140	2.3	23	7000			W 86_23	P90	BXN90S4	145
72	123	2.0	20	4160			W 75_20	P90	BXN90S4	141
72	124	2.6	20	7000			W 86_20	P90	BXN90S4	145
76	113	1.3	19	2840			W 63_19	P90	BXN90S4	138
95	92	1.6	15	2690			W 63_15	P90	BXN90S4	138
95	95	2.6	15	3850			W 75_15	P90	BXN90S4	141
95	95	3.4	15	6820			W 86_15	P90	BXN90S4	145
119	75	1.9	12	2550			W 63_12	P90	BXN90S4	138
143	64	2.2	10	2440			W 63_10	P90	BXN90S4	138
143	65	3.5	10	3420			W 75_10	P90	BXN90S4	141
189	47	2.6	15	2330						
204	45	2.6	7	2210			W 63_7	P90	BXN90S4	138
236	38	3.3	12	2190						
283	32	3.9	10	2080						

## 1.5 kW

n <sub>2</sub> min <sup>-1</sup>	M <sub>2</sub> Nm	S	i	R <sub>n2</sub> N	 IE2 IE3		 IEC			
0.30	9240	1.0	3200	52000			VF/VF 130/250_3200	P100	BE100LA6	172
0.37	8948	1.0	2560	52000			VF/VF 130/250_2560	P100	BE100LA6	172
0.45	7012	0.9	3200	34500			VF/VF 130/210_3200	P90	BE90LA4 BX90LA4	166
0.45	6693	1.3	3200	52000			VF/VF 130/250_3200	P90	BE90LA4 BX90LA4	172
0.51	8109	1.1	1840	52000			VF/VF 130/250_1840	P100	BE100LA6	172
0.56	6120	1.0	2560	34500			VF/VF 130/210_2560	P90	BE90LA4 BX90LA4	166
0.56	6375	1.4	2560	52000			VF/VF 130/250_2560	P90	BE90LA4 BX90LA4	172
0.78	6415	1.0	1840	34500			VF/VF 130/210_1840	P90	BE90LA4 BX90LA4	166
0.78	5681	1.6	1840	52000			VF/VF 130/250_1840	P90	BE90LA4 BX90LA4	172
1.0	4893	1.3	920	34500			VF/VF 130/210_920	P100	BE100LA6	166
1.0	4893	1.9	920	52000			VF/VF 130/250_920	P100	BE100LA6	172
1.2	4064	1.0	1200	19500			W /VF 86/185_1200	P90	BE90LA4 BX90LA4	160
1.2	4620	1.4	800	34500			VF/VF 130/210_800	P100	BE100LA6	166
1.2	4863	1.9	800	52000			VF/VF 130/250_800	P100	BE100LA6	172
1.5	3849	1.1	920	19500			W /VF 86/185_920	P90	BE90LA4 BX90LA4	160
1.6	3921	1.7	600	34500			VF/VF 130/210_600	P100	BE100LA6	166
1.6	3921	2.3	600	52000			VF/VF 130/250_600	P100	BE100LA6	172
1.8	3426	1.2	800	19500			W /VF 86/185_800	P90	BE90LA4 BX90LA4	160
2.4	2689	1.5	600	19500			W /VF 86/185_600	P90	BE90LA4 BX90LA4	160
2.4	2918	2.2	400	34500			VF/VF 130/210_400	P100	BE100LA6	166
2.4	2857	3.2	400	52000			VF/VF 130/250_400	P100	BE100LA6	172





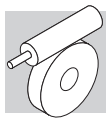

## 1.5 kW



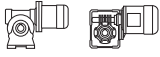

n <sub>2</sub> min <sup>-1</sup>	M <sub>2</sub> Nm	S	i	R <sub>n2</sub> N	 			 				
					IE2	IE3		IE2	IE2			
2.7	2898	0.9	529	16000				W /VF 86/150_529	P90 BE90LA4 BX90LA4	152		
3.1	2520	1.0	460	16000				W /VF 86/150_460	P90 BE90LA4 BX90LA4	152		
3.2	2280	1.0	300	19500				VFR 185_300	P100 BE100LA6	156		
3.2	2234	1.6	300	34500				VFR 210_300	P100 BE100LA6	164		
3.2	2370	2.2	300	52000				VFR 250_300	P100 BE100LA6	170		
3.4	2128	3.0	280	34500				VF/VF 130/210_280	P100 BE100LA6	166		
3.5	1753	1.0	400	13800				W /VF 63/130_400	P90 BE90LA4 BX90LA4	144		
3.5	1913	2.2	400	19500				W /VF 86/185_400	P90 BE90LA4 BX90LA4	160		
3.9	1969	0.9	240	16000				VFR 150_240	P100 BE100LA6	148		
3.9	1969	1.4	240	19500				VFR 185_240	P100 BE100LA6	156		
3.9	1969	2.2	240	34500				VFR 210_240	P100 BE100LA6	164		
4.2	1993	1.3	345	16000				W /VF 86/150_345	P90 BE90LA4 BX90LA4	152		
4.8	1643	1.4	300	19500				VFR 185_300	P90 BE90LA4 BX90LA4	156		
4.8	1733	1.5	300	16000				W /VF 86/150_300	P90 BE90LA4 BX90LA4	152		
4.9	1721	1.1	192	16000				VFR 150_192	P100 BE100LA6	148		
5.1	1394	1.3	280	13800				W /VF 63/130_280	P90 BE90LA4 BX90LA4	144		
5.1	1450	2.9	280	19500				W /VF 86/185_280	P90 BE90LA4 BX90LA4	160		
5.3	1641	2.0	180	19500				VFR 185_180	P100 BE100LA6	156		
5.3	1477	3.3	180	34500				VFR 210_180	P100 BE100LA6	164		
5.6	1532	0.9	168	13800				VFR 130_168	P100 BE100LA6	140		
6.0	1386	1.1	240	16000				VFR 150_240	P90 BE90LA4 BX90LA4	148		
6.0	1411	1.9	240	19500				VFR 185_240	P90 BE90LA4 BX90LA4	156		
6.4	1412	1.8	225	16000				W /VF 86/150_225	P90 BE90LA4 BX90LA4	152		
7.2	1275	2.0	200	16000				W /VF 86/150_200	P90 BE90LA4 BX90LA4	152		
7.4	1167	1.0	192	13800				VFR 130_192	P90 BE90LA4 BX90LA4	140		
7.4	1185	1.4	192	16000				VFR 150_192	P90 BE90LA4 BX90LA4	148		
7.9	1166	2.6	180	19500				VFR 185_180	P90 BE90LA4 BX90LA4	156		
8.5	1071	1.1	168	13800				VFR 130_168	P90 BE90LA4 BX90LA4	140		
8.5	1087	1.6	168	16000				VFR 150_168	P90 BE90LA4 BX90LA4	148		
9.5	927	1.2	100	15500				VF 150_100	P100 BE100LA6	146		
9.5	942	2.1	100	19500				VF 185_100	P100 BE100LA6	154		
9.5	1001	3.3	150	16000				VFR 185_150	P90 BE90LA4 BX90LA4	156		
10.3	921	1.4	138	13800				VFR 130_138	P90 BE90LA4 BX90LA4	140		
10.3	934	2.1	138	16000				VFR 150_138	P90 BE90LA4 BX90LA4	148		
10.5	902	1.0	90	8000				WR 110_90	P100 BE100LA6	136		
10.5	998	3.2	90	19500				VFR 185_90	P100 BE100LA6	156		
11.8	778	1.2	80	13200				VF 130_80	P100 BE100LA6	138		
11.8	790	1.7	80	15500				VF 150_80	P100 BE100LA6	146		
11.9	816	1.0	120	8000				WR 110_120	P90 BE90LA4 BX90LA4	136		
12.0	801	1.7	120	13800				VFR 130_120	P90 BE90LA4 BX90LA4	140		
12.0	813	2.4	120	16000				VFR 150_120	P90 BE90LA4 BX90LA4	148		
13.7	787	1.0	69	8000				WR 110_69	P100 BE100LA6	136		
13.7	776	1.9	69	13800				VFR 130_69	P100 BE100LA6	140		
13.7	776	2.6	69	16000				VFR 150_69	P100 BE100LA6	148		
14.8	671	2.2	64	15500				VF 150_64	P100 BE100LA6	146		
15.9	627	1.3	90	8000				WR 110_90	P90 BE90LA4 BX90LA4	136		
15.9	636	2.3	90	13800				VFR 130_90	P90 BE90LA4 BX90LA4	140		
15.9	645	3.1	90	16000				VFR 150_90	P90 BE90LA4 BX90LA4	148		
16.9	578	1.1	56	8000	W110_56	S3	ME3LB6	148	W 110_56	P100 BE100LA6	135	
16.9	595	1.8	56	13200				VF 130_56	P100 BE100LA6	138		
16.9	604	2.5	56	15500				VF 150_56	P100 BE100LA6	146		
17.8	542	1.6	80	12600				VF 130_80	P90 BE90LA4 BX90LA4	138		
20.5	497	1.3	46	8000	W110_46	S3	ME3LB6	148	W 110_46	P100 BE100LA6	135	
20.5	518	3.4	46	15500				VF 150_46	P100 BE100LA6	146		
20.7	529	1.2	69	8000				WR 110_69	P90 BE90LA4 BX90LA4	136		
20.7	523	2.4	69	13800				VFR 130_69	P90 BE90LA4 BX90LA4	140		
20.7	529	3.5	69	16000				VFR 150_69	P90 BE90LA4 BX90LA4	148		
22.3	446	1.2	64	8000	W110_64	S3	ME3SB4	MX3SB4	148	W 110_64	P90 BE90LA4 BX90LA4	135
22.3	453	2.0	64	12600				VF 130_64	P90 BE90LA4 BX90LA4	138		
23.6	444	2.7	40	13200				VF 130_40	P100 BE100LA6	138		



## 1.5 kW

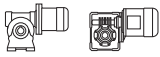

n <sub>2</sub> min-1	M <sub>2</sub> Nm	S	i	R <sub>n2</sub> N										
					IE2	IE3			IE2	IE2				
23.8	473	1.4	60	8000					WR 110_60	P90	BE90LA4	BX90LA4	136	
23.8	466	2.9	60	13800					VFR 130_60	P90	BE90LA4	BX90LA4	140	
25.6	402	1.5	56	8000	W110_56	S3	ME3SB4	MX3SB4	148	W 110_56	P90	BE90LA4	BX90LA4	135
25.6	407	2.3	56	12600					VF 130_56	P90	BE90LA4	BX90LA4	138	
31	334	1.0	46	7000	W86_46	S3	ME3SB4	MX3SB4	144	W 86_46	P90	BE90LA4	BX90LA4	131
31	339	1.8	46	8000	W110_46	S3	ME3SB4	MX3SB4	148	W 110_46	P90	BE90LA4	BX90LA4	135
31	348	3.1	46	12600					VF 130_46	P90	BE90LA4	BX90LA4	138	
32	350	1.1	45	7000					WR 86_45	P90	BE90LA4	BX90LA4	132	
32	359	2.0	45	8000					WR 110_45	P90	BE90LA4	BX90LA4	136	
35	299	1.1	40	7000	W86_40	S3	ME3SB4	MX3SB4	144	W 86_40	P90	BE90LA4	BX90LA4	131
35	303	2.2	40	8000	W110_40	S3	ME3SB4	MX3SB4	148	W 110_40	P90	BE90LA4	BX90LA4	135
38	292	0.9	25	4330	W75_25	S3	ME3LB6		140	W 75_25	P100	BE100LA6		127
38	287	0.9	38	4330					WR 75_37.5	P90	BE90LA4	BX90LA4	128	
41	279	1.2	23	7000	W86_23	S3	ME3LB6		144	W 86_23	P100	BE100LA6		131
41	275	1.3	35	7000					WR 86_34.5	P90	BE90LA4	BX90LA4	132	
48	251	1.1	30	4130					WR 75_30	P90	BE90LA4	BX90LA4	128	
48	230	1.2	30	4270	W75_30	S3	ME3SB4	MX3SB4	140	W 75_30	P90	BE90LA4	BX90LA4	127
48	245	1.4	30	7000					WR 86_30	P90	BE90LA4	BX90LA4	132	
48	227	1.6	30	7000	W86_30	S3	ME3SB4	MX3SB4	144	W 86_30	P90	BE90LA4	BX90LA4	131
48	230	3.1	30	8000	W110_30	S3	ME3SB4	MX3SB4	148	W 110_30	P90	BE90LA4	BX90LA4	135
57	199	1.3	25	4100	W75_25	S3	ME3SB4	MX3SB4	140	W 75_25	P90	BE90LA4	BX90LA4	127
62	188	1.7	23	7000	W86_23	S3	ME3SB4	MX3SB4	144	W 86_23	P90	BE90LA4	BX90LA4	131
62	190	2.8	23	8000	W110_23	S3	ME3SB4	MX3SB4	148	W 110_23	P90	BE90LA4	BX90LA4	135
72	166	1.5	20	3880	W75_20	S3	ME3SB4	MX3SB4	140	W 75_20	P90	BE90LA4	BX90LA4	127
72	168	1.9	20	7000	W86_20	S3	ME3SB4	MX3SB4	144	W 86_20	P90	BE90LA4	BX90LA4	131
72	168	3.4	20	8000	W110_20	S3	ME3SB4	MX3SB4	148	W 110_20	P90	BE90LA4	BX90LA4	135
75	153	1.0	19	2550					W 63_19	P90	BE90LA4	BX90LA4	124	
95	124	1.2	15	2450					W 63_15	P90	BE90LA4	BX90LA4	124	
95	127	2.0	15	3630	W75_15	S3	ME3SB4	MX3SB4	140	W 75_15	P90	BE90LA4	BX90LA4	127
95	128	2.4	15	6520					WR 86_15	P90	BE90LA4	BX90LA4	132	
95	127	2.6	15	6610	W86_15	S3	ME3SB4	MX3SB4	144	W 86_15	P90	BE90LA4	BX90LA4	131
120	102	1.4	12	2340					W 63_12	P90	BE90LA4	BX90LA4	124	
135	94	2.2	7	3150	W75_7	S3	ME3LB6		140	W 75_7	P100	BE100LA6		127
143	85	1.6	10	2250					W 63_10	P90	BE90LA4	BX90LA4	124	
143	87	2.6	10	3250	W75_10	S3	ME3SB4	MX3SB4	140	W 75_10	P90	BE90LA4	BX90LA4	127
143	87	3.3	10	5850	W86_10	S3	ME3SB4	MX3SB4	144	W 86_10	P90	BE90LA4	BX90LA4	131
190	65	1.9	15	2200					W 63_15	P90	BE90SA2		124	
190	67	3.4	15	3120	W75_15	S3	ME3SA2		140	W 75_15	P90	BE90SA2		127
204	62	1.9	7	2060					W 63_7	P90	BE90LA4	BX90LA4	124	
204	63	3.1	7	2920	W75_7	S3	ME3SB4	MX3SB4	140	W 75_7	P90	BE90LA4	BX90LA4	127
204	62	4.0	7	5240	W86_7	S3	ME3SB4	MX3SB4	144	W 86_7	P90	BE90LA4	BX90LA4	131
238	52	2.4	12	2080					W 63_12	P90	BE90SA2		124	
286	44	2.8	10	1980	W63_10	S3	ME3SA2		136	W 63_10	P90	BE90SA2		124

## 1.5 kW

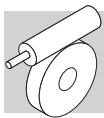
n <sub>2</sub> min-1	M <sub>2</sub> Nm	S	i	R <sub>n2</sub> N									
					IE3				IE3				
0.30	9240	1.0	3200	52000									
0.37	8948	1.0	2560	52000									
0.45	7012	0.9	3200	34500					VF/VF 130/210_3200	P90	BXN90L4		180
0.45	6693	1.3	3200	52000					VF/VF 130/250_3200	P90	BXN90L4		186
0.51	8109	1.1	1840	52000									
0.56	6120	1.0	2560	34500					VF/VF 130/210_2560	P90	BXN90L4		180
0.56	6375	1.4	2560	52000					VF/VF 130/250_2560	P90	BXN90L4		186
0.78	6415	1.0	1840	34500					VF/VF 130/210_1840	P90	BXN90L4		180
0.78	5681	1.6	1840	52000					VF/VF 130/250_1840	P90	BXN90L4		186

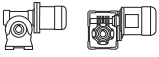

## 1.5 kW

n <sub>2</sub> min-1	M <sub>2</sub> Nm	S	i	R <sub>n2</sub> N	 IE3		 IEC			
					W /VF		P90	BXN90L4		
1.0	4893	1.3	920	34500						
1.0	4893	1.9	920	52000						
1.2	4064	1.0	1200	19500			W /VF 86/185_1200	P90	BXN90L4	174
1.2	4620	1.4	800	34500						
1.2	4863	1.9	800	52000						
1.5	3849	1.1	920	19500			W /VF 86/185_920	P90	BXN90L4	174
1.6	3921	1.7	600	34500						
1.6	3921	2.3	600	52000						
1.8	3426	1.2	800	19500			W /VF 86/185_800	P90	BXN90L4	174
2.4	2689	1.5	600	19500			W /VF 86/185_600	P90	BXN90L4	174
2.4	2918	2.2	400	34500						
2.4	2857	3.2	400	52000						
2.7	2898	0.9	529	16000			W /VF 86/150_529	P90	BXN90L4	166
3.1	2520	1.0	460	16000			W /VF 86/150_460	P90	BXN90L4	166
3.2	2280	1.0	300	19500						
3.2	2234	1.6	300	34500						
3.2	2370	2.2	300	52000						
3.4	2128	3.0	280	34500						
3.5	1753	1.0	400	13800			W /VF 63/130_400	P90	BXN90L4	158
3.5	1913	2.2	400	19500			W /VF 86/185_400	P90	BXN90L4	174
3.9	1969	0.9	240	16000						
3.9	1969	1.4	240	19500						
3.9	1969	2.2	240	34500						
4.2	1993	1.3	345	16000			W /VF 86/150_345	P90	BXN90L4	166
4.8	1643	1.4	300	19500			VFR 185_300	P90	BXN90L4	170
4.8	1733	1.5	300	16000			W /VF 86/150_300	P90	BXN90L4	166
4.9	1721	1.1	192	16000						
5.1	1394	1.3	280	13800			W /VF 63/130_280	P90	BXN90L4	158
5.1	1450	2.9	280	19500			W /VF 86/185_280	P90	BXN90L4	174
5.3	1641	2.0	180	19500						
5.3	1477	3.3	180	34500						
5.6	1532	0.9	168	13800						
6.0	1386	1.1	240	16000			VFR 150_240	P90	BXN90L4	162
6.0	1411	1.9	240	19500			VFR 185_240	P90	BXN90L4	170
6.4	1412	1.8	225	16000			W /VF 86/150_225	P90	BXN90L4	166
7.2	1275	2.0	200	16000			W /VF 86/150_200	P90	BXN90L4	166
7.4	1167	1.0	192	13800			VFR 130_192	P90	BXN90L4	154
7.4	1185	1.4	192	16000			VFR 150_192	P90	BXN90L4	162
7.9	1166	2.6	180	19500			VFR 185_180	P90	BXN90L4	170
8.5	1071	1.1	168	13800			VFR 130_168	P90	BXN90L4	154
8.5	1087	1.6	168	16000			VFR 150_168	P90	BXN90L4	162
9.5	927	1.2	100	15500						
9.5	942	2.1	100	19500						
9.5	1001	3.3	150	16000			VFR 185_150	P90	BXN90L4	170
10.3	921	1.4	138	13800			VFR 130_138	P90	BXN90L4	154
10.3	934	2.1	138	16000			VFR 150_138	P90	BXN90L4	162
10.5	902	1.0	90	8000						
10.5	998	3.2	90	19500						
11.8	778	1.2	80	13200						
11.8	790	1.7	80	15500						
11.9	816	1.0	120	8000			WR 110_120	P90	BXN90L4	150
12.0	801	1.7	120	13800			VFR 130_120	P90	BXN90L4	154
12.0	813	2.4	120	16000			VFR 150_120	P90	BXN90L4	162
13.7	787	1.0	69	8000						
13.7	776	1.9	69	13800						
13.7	776	2.6	69	16000						
14.8	671	2.2	64	15500						
15.9	627	1.3	90	8000			WR 110_90	P90	BXN90L4	150
15.9	636	2.3	90	13800			VFR 130_90	P90	BXN90L4	154
15.9	645	3.1	90	16000			VFR 150_90	P90	BXN90L4	162



## 1.5 kW

n <sub>2</sub> min <sup>-1</sup>	M <sub>2</sub> Nm	S	i	R <sub>n2</sub> N	IE3		IEC		
16.9	578	1.1	56	8000					
16.9	595	1.8	56	13200					
16.9	604	2.5	56	15500					
17.8	542	1.6	80	12600			VF 130_80	P90 BXN90L4	152
20.5	497	1.3	46	8000					
20.5	518	3.4	46	15500					
20.7	529	1.2	69	8000			WR 110_69	P90 BXN90L4	150
20.7	523	2.4	69	13800			VFR 130_69	P90 BXN90L4	154
20.7	529	3.5	69	16000			VFR 150_69	P90 BXN90L4	162
22.3	446	1.2	64	8000			W 110_64	P90 BXN90L4	149
22.3	453	2.0	64	12600			VF 130_64	P90 BXN90L4	152
23.6	444	2.7	40	13200					
23.8	473	1.4	60	8000			WR 110_60	P90 BXN90L4	150
23.8	466	2.9	60	13800			VFR 130_60	P90 BXN90L4	154
25.6	402	1.5	56	8000			W 110_56	P90 BXN90L4	149
25.6	407	2.3	56	12600			VF 130_56	P90 BXN90L4	152
31	334	1.0	46	7000			W 86_46	P90 BXN90L4	145
31	339	1.8	46	8000			W 110_46	P90 BXN90L4	149
31	348	3.1	46	12600			VF 130_46	P90 BXN90L4	152
32	350	1.1	45	7000			WR 86_45	P90 BXN90L4	146
32	359	2.0	45	8000			WR 110_45	P90 BXN90L4	150
35	299	1.1	40	7000			W 86_40	P90 BXN90L4	145
35	303	2.2	40	8000			W 110_40	P90 BXN90L4	149
38	292	0.9	25	4330					
38	287	0.9	38	4330			WR 75_37.5	P90 BXN90L4	142
41	279	1.2	23	7000					
41	275	1.3	35	7000			WR 86_34.5	P90 BXN90L4	146
48	251	1.1	30	4130			WR 75_30	P90 BXN90L4	142
48	230	1.2	30	4270			W 75_30	P90 BXN90L4	141
48	245	1.4	30	7000			WR 86_30	P90 BXN90L4	146
48	227	1.6	30	7000			W 86_30	P90 BXN90L4	145
48	230	3.1	30	8000			W 110_30	P90 BXN90L4	149
57	199	1.3	25	4100			W 75_25	P90 BXN90L4	141
62	188	1.7	23	7000			W 86_23	P90 BXN90L4	145
62	190	2.8	23	8000			W 110_23	P90 BXN90L4	149
72	166	1.5	20	3880			W 75_20	P90 BXN90L4	141
72	168	1.9	20	7000			W 86_20	P90 BXN90L4	145
72	168	3.4	20	8000			W 110_20	P90 BXN90L4	149
75	153	1.0	19	2550			W 63_19	P90 BXN90L4	138
95	124	1.2	15	2450			W 63_15	P90 BXN90L4	138
95	127	2.0	15	3630			W 75_15	P90 BXN90L4	141
95	128	2.4	15	6520			WR 86_15	P90 BXN90L4	146
95	127	2.6	15	6610			W 86_15	P90 BXN90L4	145
120	102	1.4	12	2340			W 63_12	P90 BXN90L4	138
135	94	2.2	7	3150					
143	85	1.6	10	2250			W 63_10	P90 BXN90L4	138
143	87	2.6	10	3250			W 75_10	P90 BXN90L4	141
143	87	3.3	10	5850			W 86_10	P90 BXN90L4	145
190	65	1.9	15	2200					
190	67	3.4	15	3120					
204	62	1.9	7	2060			W 63_7	P90 BXN90L4	138
204	63	3.1	7	2920			W 75_7	P90 BXN90L4	141
204	62	4.0	7	5240			W 86_7	P90 BXN90L4	145
238	52	2.4	12	2080					
286	44	2.8	10	1980					

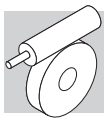

## 2.2 kW

n <sub>2</sub> min <sup>-1</sup>	M <sub>2</sub> Nm	S	i	R <sub>n2</sub> N								
					IE2	IE3	IE2	IE3				
0.45	9879	0.9	3200	52000				VF/VF 130/250_3200	P100	BE100LA4	BX100LA4	186
0.56	9408	0.9	2560	52000				VF/VF 130/250_2560	P100	BE100LA4	BX100LA4	186
0.78	8385	1.1	1840	52000				VF/VF 130/250_1840	P100	BE100LA4	BX100LA4	186
0.89	7527	1.2	1600	52000				VF/VF 130/250_1600	P100	BE100LA4	BX100LA4	186
1.0	6884	0.9	920	34500				VF/VF 130/210_920	P112	BE112M6		180
1.0	6884	1.4	920	52000				VF/VF 130/250_920	P112	BE112M6		186
1.2	6174	1.0	1200	34500				VF/VF 130/210_1200	P100	BE100LA4	BX100LA4	180
1.2	6174	1.4	1200	52000				VF/VF 130/250_1200	P100	BE100LA4	BX100LA4	186
1.5	5004	1.2	920	34500				VF/VF 130/210_920	P100	BE100LA4	BX100LA4	180
1.5	5004	1.8	920	52000				VF/VF 130/250_920	P100	BE100LA4	BX100LA4	186
1.8	4821	1.3	800	34500				VF/VF 130/210_800	P100	BE100LA4	BX100LA4	180
1.8	4940	1.8	800	52000				VF/VF 130/250_800	P100	BE100LA4	BX100LA4	186
2.4	3969	1.0	600	19500				W /VF 86/185_600	P100	BE100LA4	BX100LA4	174
2.4	3792	1.6	600	34500				VF/VF 130/210_600	P100	BE100LA4	BX100LA4	180
2.4	3881	2.3	600	52000				VF/VF 130/250_600	P100	BE100LA4	BX100LA4	186
3.2	3143	1.2	300	34500				VFR 210_300	P112	BE112M6		178
3.2	3335	1.6	300	52000				VFR 250_300	P112	BE112M6		184
3.5	2823	1.5	400	19500				W /VF 86/185_400	P100	BE100LA4	BX100LA4	174
3.5	2940	2.1	400	34500				VF/VF 130/210_400	P100	BE100LA4	BX100LA4	180
3.5	2882	3.1	400	52000				VF/VF 130/250_400	P100	BE100LA4	BX100LA4	186
4.0	2771	1.0	240	19500				VFR 185_240	P112	BE112M6		170
4.0	2771	1.6	240	34500				VFR 210_240	P112	BE112M6		178
4.0	2873	2.0	240	52000				VFR 250_240	P112	BE112M6		184
4.8	2426	0.9	300	19500				VFR 185_300	P100	BE100LA4	BX100LA4	170
4.8	2426	1.4	300	34500				VFR 210_300	P100	BE100LA4	BX100LA4	178
4.8	2514	2.0	300	52000				VFR 250_300	P100	BE100LA4	BX100LA4	184
5.1	2141	1.9	280	19500				W /VF 86/185_280	P100	BE100LA4	BX100LA4	174
5.1	2141	2.9	280	34500				VF/VF 130/210_280	P100	BE100LA4	BX100LA4	180
5.7	2191	0.9	168	16000				VFR 150_168	P112	BE112M6		162
6.0	2082	1.3	240	19500				VFR 185_240	P100	BE100LA4	BX100LA4	170
6.0	2082	1.8	240	34500				VFR 210_240	P100	BE100LA4	BX100LA4	178
6.0	2152	2.5	240	52000				VFR 250_240	P100	BE100LA4	BX100LA4	184
7.4	1750	1.0	192	16000				VFR 150_192	P100	BE100LA4	BX100LA4	162
7.9	1720	1.7	180	19500				VFR 185_180	P100	BE100LA4	BX100LA4	170
7.9	1694	2.5	180	34500				VFR 210_180	P100	BE100LA4	BX100LA4	178
7.9	1773	3.5	180	52000				VFR 250_180	P100	BE100LA4	BX100LA4	184
8.0	1616	0.9	120	13800				VFR 130_120	P112	BE112M6		154
8.5	1605	1.1	168	16000				VFR 150_168	P100	BE100LA4	BX100LA4	162
9.5	1478	2.2	150	19500				VFR 185_150	P100	BE100LA4	BX100LA4	170
9.5	1478	3.0	150	34500				VFR 210_150	P100	BE100LA4	BX100LA4	178
9.6	1326	1.5	100	19000				VF 185_100	P112	BE112M6		168
10.3	1360	1.0	138	13800				VFR 130_138	P100	BE100LA4	BX100LA4	154
10.3	1379	1.4	138	16000				VFR 150_138	P100	BE100LA4	BX100LA4	162
10.6	1404	2.3	90	19500				VFR 185_90	P112	BE112M6		170
10.6	1385	3.3	90	34500				VFR 210_90	P112	BE112M6		178
11.9	1111	1.3	80	15500				VF 150_80	P112	BE112M6		160
11.9	1129	2.1	80	19000				VF 185_80	P112	BE112M6		168
12.0	1182	1.2	120	13800				VFR 130_120	P100	BE100LA4	BX100LA4	154
12.0	1200	1.6	120	16000				VFR 150_120	P100	BE100LA4	BX100LA4	162
12.0	1235	2.9	120	19500				VFR 185_120	P100	BE100LA4	BX100LA4	170
12.0	1235	4.1	120	34500				VFR 210_120	P100	BE100LA4	BX100LA4	178
13.8	1091	1.4	69	13800				VFR 130_69	P112	BE112M6		154
13.8	1091	1.9	69	16000				VFR 150_69	P112	BE112M6		162
14.3	956	1.2	100	14700				VF 150_100	P100	BE100LA4	BX100LA4	160
14.3	956	2.0	100	18000				VF 185_100	P100	BE100LA4	BX100LA4	168
14.9	931	1.2	64	13200				VF 130_64	P112	BE112M6		152
15.9	939	1.6	90	13800				VFR 130_90	P100	BE100LA4	BX100LA4	154
15.9	953	2.0	90	16000				VFR 150_90	P100	BE100LA4	BX100LA4	162
15.9	911	2.8	60	19000				VF 185_60	P112	BE112M6		168
15.9	1005	2.7	90	19500				VFR 185_90	P100	BE100LA4	BX100LA4	170
17.1	838	1.3	56	13200				VF 130_56	P112	BE112M6		152
17.8	800	1.1	80	12600				VF 130_80	P100	BE100LA4	BX100LA4	152
17.8	812	1.5	80	14700				VF 150_80	P100	BE100LA4	BX100LA4	160





## 2.2 kW

n <sub>2</sub> min-1	M <sub>2</sub> Nm	S	i	R <sub>n2</sub> N	 IE2 IE3			 IEC IE2 IE3						
					17.8	812		2.6	80	18000				
20.7	771	1.7	69	13800				VFR 130_69	P100	BE100LA4	BX100LA4	154		
20.7	781	2.3	69	16000				VFR 150_69	P100	BE100LA4	BX100LA4	162		
20.8	718	1.6	46	13200				VF 130_46	P112	BE112M6		152		
20.8	728	2.4	46	15500				VF 150_46	P112	BE112M6		160		
21.2	762	1.1	45	8000				WR 110_45	P112	BE112M6		150		
22.3	668	1.4	64	12600				VF 130_64	P100	BE100LA4	BX100LA4	152		
22.3	678	1.9	64	14700				VF 150_64	P100	BE100LA4	BX100LA4	160		
23.8	697	1.0	60	8000				WR 110_60	P100	BE100LA4	BX100LA4	150		
23.8	688	1.9	60	13800				VFR 130_60	P100	BE100LA4	BX100LA4	154		
23.8	697	2.7	60	16000				VFR 150_60	P100	BE100LA4	BX100LA4	162		
23.8	653	3.4	60	18000				VF 185_60	P100	BE100LA4	BX100LA4	168		
23.9	631	1.2	40	8000				W 110_40	P112	BE112M6	BE112M6	149		
25.6	593	1.0	56	8000	W110_56	S3	ME3LA4	MX3LA4	148	W 110_56	P100	BE100LA4	BX100LA4	149
25.6	601	1.6	56	12600				VF 130_56	P100	BE100LA4	BX100LA4	152		
25.6	609	2.2	56	14200				VF 150_56	P100	BE100LA4	BX100LA4	160		
31	500	1.2	46	8000	W110_46	S3	ME3LA4	MX3LA4	148	W 110_46	P100	BE100LA4	BX100LA4	149
31	514	2.0	46	12600				VF 130_46	P100	BE100LA4	BX100LA4	152		
31	521	2.9	46	14700				VF 150_46	P100	BE100LA4	BX100LA4	160		
32	529	1.3	45	8000				WR 110_45	P100	BE100LA4	BX100LA4	150		
31	543	3.1	45	16000				VFR 150_45	P100	BE100LA4	BX100LA4	162		
35	447	1.5	40	8000	W110_40	S3	ME3LA4	MX3LA4	148	W 110_40	P100	BE100LA4	BX100LA4	149
35	447	2.4	40	12600				VF 130_40	P100	BE100LA4	BX100LA4	152		
35	453	3.4	40	14700				VF 150_40	P100	BE100LA4	BX100LA4	160		
42	398	2.6	23	13200				VF 130_23	P112	BE112M6		152		
48	335	1.1	30	7000	W86_30	S3	ME3LA4	MX3LA4	144	W 86_30	P100	BE100LA4	BX100LA4	145
48	339	2.1	30	8000	W110_30	S3	ME3LA4	MX3LA4	148	W 110_30	P100	BE100LA4	BX100LA4	149
48	348	3.0	30	12600				VF 130_30	P100	BE100LA4	BX100LA4	152		
62	277	1.2	23	6990	W86_23	S3	ME3LA4	MX3LA4	144	W 86_23	P100	BE100LA4	BX100LA4	145
62	280	1.9	23	8000	W110_23	S3	ME3LA4	MX3LA4	148	W 110_23	P100	BE100LA4	BX100LA4	149
62	280	3.1	23	12600				VF 130_23	P100	BE100LA4	BX100LA4	152		
72	244	1.0	20	3410	W75_20	S3	ME3LA4	MX3LA4	140	W 75_20	P100	BE100LA4	BX100LA4	141
72	247	1.3	20	6730	W86_20	S3	ME3LA4	MX3LA4	144	W 86_20	P100	BE100LA4	BX100LA4	145
72	247	2.3	20	8000	W110_20	S3	ME3LA4	MX3LA4	148	W 110_20	P100	BE100LA4	BX100LA4	149
95	187	1.3	15	3240	W75_15	S3	ME3LA4	MX3LA4	140	W 75_15	P100	BE100LA4	BX100LA4	141
95	187	1.8	15	6270	W86_15	S3	ME3LA4	MX3LA4	144	W 86_15	P100	BE100LA4	BX100LA4	145
95	185	3.2	15	8000	W110_15	S3	ME3LA4	MX3LA4	148	W 110_15	P100	BE100LA4	BX100LA4	149
136	133	1.6	7	2780				W 75_7	P112	BE112M6		141		
136	133	2.0	7	5540				W 86_7	P112	BE112M6		145		
143	129	1.8	10	2940	W75_10	S3	ME3LA4	MX3LA4	140	W 75_10	P100	BE100LA4	BX100LA4	141
143	129	2.2	10	5590	W86_10	S3	ME3LA4	MX3LA4	144	W 86_10	P100	BE100LA4	BX100LA4	145
191	98	2.3	15	2920	W75_15	S3	ME3LA2		140	W 75_15	P90	BE90L2	141	
191	93	1.3	15	1980				W 63_15	P90	BE90L2		138		
204	93	2.1	7	2660	W75_7	S3	ME3LA4	MX3LA4	140	W 75_7	P100	BE100LA4	BX100LA4	141
204	92	2.7	7	5030	W86_7	S3	ME3LA4	MX3LA4	144	W 86_7	P100	BE100LA4	BX100LA4	145
239	75	1.6	12	1890				W 63_12	P90	BE90L2		138		
287	66	3.0	10	2610	W75_10	S3	ME3LA2		140	W 75_10	P90	BE90L2	141	
287	63	1.9	10	1820				W 63_10	P90	BE90L2		138		
409	48	3.6	7	2350	W75_7	S3	ME3LA2		140	W 75_7	P90	BE90L2	141	
409	46	2.3	7	1660				W 63_7	P90	BE90L2		138		

## 3 kW

n <sub>2</sub> min-1	M <sub>2</sub> Nm	S	i	R <sub>n2</sub> N	 IE2 IE3			 IEC IE2 IE3				
					0.90	10403		0.9	1600	52000		
1.0	9813	0.9	920	52000				VF/VF 130/250_920	P132	BE132S6		186
1.2	8534	1.1	1200	52000				VF/VF 130/250_1200	P100	BE100LB4	BX100LB4	186
1.5	6917	0.9	920	34500				VF/VF 130/210_920	P100	BE100LB4	BX100LB4	180
1.5	6917	1.3	920	52000				VF/VF 130/250_920	P100	BE100LB4	BX100LB4	186

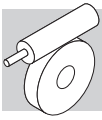

## 3 kW

n <sub>2</sub> min <sup>-1</sup>	M <sub>2</sub> Nm	S	i	R <sub>n2</sub> N									
					IE2	IE3		IE2	IE3				
1.8	6665	0.9	800	34500				VF/VF 130/210_800	P100	BE100LB4	BX100LB4	180	
1.8	6827	1.3	800	52000				VF/VF 130/250_800	P100	BE100LB4	BX100LB4	186	
2.5	5242	1.2	600	34500				VF/VF 130/210_600	P100	BE100LB4	BX100LB4	180	
2.5	5364	1.7	600	52000				VF/VF 130/250_600	P100	BE100LB4	BX100LB4	186	
3.2	4755	1.1	300	52000				VFR 250_300	P132	BE132S6		184	
3.6	3901	1.1	400	19500				W /VF 86/185_400	P100	BE100LB4	BX100LB4	174	
3.6	4064	1.6	400	34500				VF/VF 130/210_400	P100	BE100LB4	BX100LB4	180	
3.6	3983	2.3	400	52000				VF/VF 130/250_400	P100	BE100LB4	BX100LB4	186	
4.0	3950	1.1	240	34500				VFR 210_240	P132	BE132S6		178	
4.0	4096	1.4	240	52000				VFR 250_240	P132	BE132S6		184	
4.8	3353	1.0	300	34500				VFR 210_300	P100	BE100LB4	BX100LB4	178	
4.8	3475	1.4	300	52000				VFR 250_300	P100	BE100LB4	BX100LB4	184	
5.1	2958	1.4	280	19500				W /VF 86/185_280	P100	BE100LB4	BX100LB4	174	
5.1	2958	2.1	280	34500				VF/VF 130/210_280	P100	BE100LB4	BX100LB4	180	
5.1	3015	3.0	280	52000				VF/VF 130/250_280	P100	BE100LB4	BX100LB4	186	
6.0	2877	1.0	240	19500				VFR 185_240	P100	BE100LB4	BX100LB4	170	
6.0	2877	1.4	240	34500				VFR 210_240	P100	BE100LB4	BX100LB4	178	
6.0	2975	1.8	240	52000				VFR 250_240	P100	BE100LB4	BX100LB4	184	
8.0	2377	1.3	180	19500				VFR 185_180	P100	BE100LB4	BX100LB4	170	
8.0	2341	1.8	180	34500				VFR 210_180	P100	BE100LB4	BX100LB4	178	
8.0	2450	2.6	180	52000				VFR 250_180	P100	BE100LB4	BX100LB4	184	
9.6	2042	1.6	150	19500				VFR 185_150	P100	BE100LB4	BX100LB4	170	
9.6	1859	1.6	100	33000				VF 210_100	P132	BE132S6		176	
9.6	2042	2.2	150	34500				VFR 210_150	P100	BE100LB4	BX100LB4	178	
9.6	1920	2.5	100	50000				VF 250_100	P132	BE132S6		182	
9.6	2042	3.2	150	52000				VFR 250_150	P100	BE100LB4	BX100LB4	184	
10.4	1907	1.0	138	16000				VFR 150_138	P100	BE100LB4	BX100LB4	162	
11.9	1609	1.5	80	19000				VF 185_80	P132	BE132S6		168	
11.9	1585	2.1	80	33000				VF 210_80	P132	BE132S6		176	
12.1	1634	0.9	120	13800				VFR 130_120	P100	BE100LB4	BX100LB4	154	
12.1	1658	1.2	120	16000				VFR 150_120	P100	BE100LB4	BX100LB4	162	
12.1	1707	2.1	120	19500				VFR 185_120	P100	BE100LB4	BX100LB4	170	
12.1	1707	2.9	120	34500				VFR 210_120	P100	BE100LB4	BX100LB4	178	
12.1	1731	4.0	120	52000				VFR 250_120	P100	BE100LB4	BX100LB4	184	
14.4	1321	0.9	100	14700				VF 150_100	P100	BE100LB4	BX100LB4	160	
14.4	1321	1.4	100	18000				VF 185_100	P100	BE100LB4	BX100LB4	168	
15.9	1298	2.0	60	19000				VF 185_60	P132	BE132S6		168	
15.9	1280	2.9	60	33000				VF 210_60	P132	BE132S6		176	
16.0	1298	1.2	90	13800				VFR 130_90	P100	BE100LB4	BX100LB4	154	
16.0	1317	1.5	90	16000				VFR 150_90	P100	BE100LB4	BX100LB4	162	
16.0	1390	2.0	90	19500				VFR 185_90	P100	BE100LB4	BX100LB4	170	
16.0	1390	2.9	90	34500				VFR 210_90	P100	BE100LB4	BX100LB4	178	
18.0	1122	1.1	80	14700				VF 150_80	P100	BE100LB4	BX100LB4	160	
18.0	1122	1.9	80	18000				VF 185_80	P100	BE100LB4	BX100LB4	168	
20.8	1066	1.2	69	13800				VFR 130_69	P100	BE100LB4	BX100LB4	154	
20.8	1080	1.7	69	16000				VFR 150_69	P100	BE100LB4	BX100LB4	162	
22.5	923	1.0	64	12600				VF 130_64	P100	BE100LB4	BX100LB4	152	
22.5	936	1.4	64	14700				VF 150_64	P100	BE100LB4	BX100LB4	160	
24.0	951	1.4	60	13800				VFR 130_60	P100	BE100LB4	BX100LB4	154	
24.0	963	2.0	60	16000				VFR 150_60	P100	BE100LB4	BX100LB4	162	
24.0	902	2.5	60	18000				VF 185_60	P100	BE100LB4	BX100LB4	168	
25.7	831	1.2	56	12600				VF 130_56	P100	BE100LB4	BX100LB4	152	
25.7	842	1.6	56	14700				VF 150_56	P100	BE100LB4	BX100LB4	160	
28.8	772	3.2	50	18000				VF 185_50	P100	BE100LB4	BX100LB4	168	
32	710	1.5	46	12600				VF 130_46	P100	BE100LB4	BX100LB4	152	
32	720	2.2	46	14700				VF 150_46	P100	BE100LB4	BX100LB4	160	
32	720	1.0	45	8000				WR 110_45	P100	BE100LB4	BX100LB4	150	
32	750	2.3	45	16000				VFR 150_45	P100	BE100LB4	BX100LB4	162	
36	608	1.1	40	8000	W110_40 S3	ME3LB4	MX3LB4	148	W 110_40	P100	BE100LB4	BX100LB4	149
36	618	1.8	40	12600				VF 130_40	P100	BE100LB4	BX100LB4	152	
36	626	2.5	40	14700				VF 150_40	P100	BE100LB4	BX100LB4	160	
42	568	1.0	23	8000				W 110_23	P132	BE132S6		149	
42	568	1.8	23	13200				VF 130_23	P132	BE132S6		152	

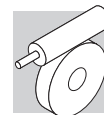

### 3 kW







n <sub>2</sub> min-1	M <sub>2</sub> Nm	S	i	R <sub>n2</sub> N	IE2		IE3		IEC	IE2		IE3		IEC
48	462	1.5	30	8000	W110_30	S3	ME3LB4	MX3LB4	148	W 110_30	P100	BE100LB4	BX100LB4	149
48	482	2.2	30	12600						VF 130_30	P100	BE100LB4	BX100LB4	152
48	488	2.8	30	14700						VF 150_30	P100	BE100LB4	BX100LB4	160
48	518	2.9	30	16000						VFR 150_30	P100	BE100LB4	BX100LB4	162
62	382	1.4	23	8000	W110_23	S3	ME3LB4	MX3LB4	148	W 110_23	P100	BE100LB4	BX100LB4	149
62	388	2.3	23	12600						VF 130_23	P100	BE100LB4	BX100LB4	152
62	388	3.3	23	14700						VF 150_23	P100	BE100LB4	BX100LB4	160
72	336	1.0	20	6240	W86_20	S3	ME3LB4	MX3LB4	144	W 86_20	P100	BE100LB4	BX100LB4	145
72	336	1.7	20	8000	W110_20	S3	ME3LB4	MX3LB4	148	W 110_20	P100	BE100LB4	BX100LB4	149
73	341	2.6	20	12600						VF 130_20	P100	BE100LB4	BX100LB4	152
96	259	1.0	15	2800	W75_15	S3	ME3LB4	MX3LB4	140	W 75_15	P100	BE100LB4	BX100LB4	141
96	259	1.3	15	5890	W86_15	S3	ME3LB4	MX3LB4	144	W 86_15	P100	BE100LB4	BX100LB4	145
96	256	2.4	15	8000	W110_15	S3	ME3LB4	MX3LB4	148	W 110_15	P100	BE100LB4	BX100LB4	149
96	262	3.5	15	11800						VF 130_15	P100	BE100LB4	BX100LB4	152
125	197	3.4	23	11000						VF 130_23	P100	BE100L2		152
144	179	1.3	10	2600	W75_10	S3	ME3LB4	MX3LB4	140	W 75_10	P100	BE100LB4	BX100LB4	141
144	179	1.6	10	5300	W86_10	S3	ME3LB4	MX3LB4	144	W 86_10	P100	BE100LB4	BX100LB4	145
144	177	3.1	10	8000	W110_10	S3	ME3LB4	MX3LB4	148	W 110_10	P100	BE100LB4	BX100LB4	149
192	131	1.7	15	2680	W75_15	S3	ME3LB2		140	W 75_15	P100	BE100L2		141
192	130	2.3	15	5070	W86_15	S3	ME3LB2		144	W 86_15	P100	BE100L2		145
206	128	1.5	7	2380	W75_7	S3	ME3LB4	MX3LB4	140	W 75_7	P100	BE100LB4	BX100LB4	141
206	127	2.0	7	4780	W86_7	S3	ME3LB4	MX3LB4	144	W 86_7	P100	BE100LB4	BX100LB4	145
288	90	2.3	10	2430	W75_10	S3	ME3LB2		140	W 75_10	P100	BE100L2		141
288	90	2.9	10	4510	W86_10	S3	ME3LB2		144	W 86_10	P100	BE100L2		145
411	64	2.7	7	2190	W75_7	S3	ME3LB2		140	W 75_7	P100	BE100L2		141
411	64	3.5	7	4040	W86_7	S3	ME3LB2		144	W 86_7	P100	BE100L2		145

### 4 kW

n <sub>2</sub> min-1	M <sub>2</sub> Nm	S	i	R <sub>n2</sub> N	IE2		IE3		IEC	IE2		IE3		IEC
1.5	9157	1.0	920	52000						VF/VF 130/250_920	P112	BE112M4	BX112M4	186
1.9	9039	1.0	800	52000						VF/VF 130/250_800	P112	BE112M4	BX112M4	186
2.5	6941	0.9	600	34500						VF/VF 130/210_600	P112	BE112M4	BX112M4	180
2.5	7102	1.3	600	52000						VF/VF 130/250_600	P112	BE112M4	BX112M4	186
3.7	5380	1.2	400	34500						VF/VF 130/210_400	P112	BE112M4	BX112M4	180
3.7	5273	1.7	400	52000						VF/VF 130/250_400	P112	BE112M4	BX112M4	186
4.0	5348	1.1	240	52000						VFR 250_240	P132	BE132MA6		184
4.8	4600	1.1	300	52000						VFR 250_300	P112	BE112M4	BX112M4	184
5.2	3917	1.1	280	19500						W / VF 86/185_280	P112	BE112M4	BX112M4	174
5.2	3917	1.6	280	34500						VF/VF 130/210_280	P112	BE112M4	BX112M4	180
5.2	3992	2.3	280	52000						VF/VF 130/250_280	P112	BE112M4	BX112M4	186
5.4	3867	1.3	180	34500						VFR 210_180	P132	BE132MA6		178
5.4	4440	1.5	180	52000						VFR 250_180	P132	BE132MA6		184
6.1	3809	1.0	240	34500						VFR 210_240	P112	BE112M4	BX112M4	178
6.1	3938	1.4	240	52000						VFR 250_240	P112	BE112M4	BX112M4	184
8.1	3147	1.0	180	19500						VFR 185_180	P112	BE112M4	BX112M4	170
8.1	3099	1.4	180	34500						VFR 210_180	P112	BE112M4	BX112M4	178
8.1	3244	1.9	180	52000						VFR 250_180	P112	BE112M4	BX112M4	184
9.7	2427	1.2	100	33000						VF 210_100	P132	BE132MA6		176
9.7	2507	1.9	100	50000						VF 250_100	P132	BE132MA6		182
9.8	2704	1.2	150	19500						VFR 185_150	P112	BE112M4	BX112M4	170
9.8	2704	1.7	150	34500						VFR 210_150	P112	BE112M4	BX112M4	178
9.8	2704	2.4	150	52000						VFR 250_150	P112	BE112M4	BX112M4	184
12.1	2195	0.9	120	16000						VFR 150_120	P112	BE112M4	BX112M4	162
12.1	2260	1.6	120	19500						VFR 185_120	P112	BE112M4	BX112M4	170
12.1	2260	2.2	120	34500						VFR 210_120	P112	BE112M4	BX112M4	178
12.1	2292	3.1	120	52000						VFR 250_120	P112	BE112M4	BX112M4	184
14.6	1749	1.1	100	18000						VF 185_100	P112	BE112M4	BX112M4	168
16.1	1695	1.5	60	19000						VF 185_60	P132	BE132MA6		168
16.1	1671	2.2	60	33000						VF 210_60	P132	BE132MA6		176



## 4 kW

n <sub>2</sub> min <sup>-1</sup>	M <sub>2</sub> Nm	S	i	R <sub>n2</sub> N	 			 		
					IE2	IE3		IE2	IE2	
16.1	1719	3.2	60	50000				VF 250_60	P132 BE132MA6	182
16.3	1719	0.9	90	13800				VFR 130_90	P112 BE112M4 BX112M4	154
16.3	1743	1.1	90	16000				VFR 150_90	P112 BE112M4 BX112M4	162
16.3	1840	1.5	90	19500				VFR 185_90	P112 BE112M4 BX112M4	170
16.3	1840	2.2	90	34500				VFR 210_90	P112 BE112M4 BX112M4	178
16.3	1888	3.2	90	52000				VFR 250_90	P112 BE112M4 BX112M4	184
18.3	1485	1.4	80	18000				VF 185_80	P112 BE112M4 BX112M4	168
21.0	1355	1.3	46	15500				VF 150_46	P132 BE132MA6	160
21.2	1411	0.9	69	13800				VFR 130_69	P112 BE112M4 BX112M4	154
21.2	1429	1.3	69	16000				VFR 150_69	P112 BE112M4 BX112M4	162
21.4	1433	3.4	45	34500				VFR 210_45	P132 BE132MA6	178
22.8	1240	1.1	64	14700				VF 150_64	P112 BE112M4 BX112M4	160
24.1	1162	1.0	40	13200				VF 130_40	P132 BE132MA6	152
24.1	1193	3.6	40	33000				VF 210_40	P132 BE132MA6	176
24.4	1259	1.1	60	13800				VFR 130_60	P112 BE112M4 BX112M4	154
24.4	1275	1.5	60	16000				VFR 150_60	P112 BE112M4 BX112M4	162
24.4	1194	1.9	60	18000				VF 185_60	P112 BE112M4 BX112M4	168
24.4	1307	2.5	60	19500				VFR 185_60	P112 BE112M4 BX112M4	170
24.4	1291	3.6	60	34500				VFR 210_60	P112 BE112M4 BX112M4	178
26.1	1100	0.9	56	12500				VF 130_56	P112 BE112M4 BX112M4	152
26.1	1115	1.2	56	14700				VF 150_56	P112 BE112M4 BX112M4	160
29.2	1022	2.4	50	18000				VF 185_50	P112 BE112M4 BX112M4	168
32	940	1.1	46	12600				VF 130_46	P112 BE112M4 BX112M4	152
32	953	1.6	46	14700				VF 150_46	P112 BE112M4 BX112M4	160
32	967	2.5	30	19000				VF 185_30	P132 BE132MA6	168
32	955	3.5	30	33000				VF 210_30	P132 BE132MA6	176
33	993	1.7	45	16000				VFR 150_45	P112 BE112M4 BX112M4	162
33	1017	2.8	45	19500				VFR 185_45	P112 BE112M4 BX112M4	170
36	762	0.9	80	12600				VF 130_80	P112 BE112M2	152
37	818	1.3	40	12600				VF 130_40	P112 BE112M4 BX112M4	152
37	829	1.9	40	14700				VF 150_40	P112 BE112M4 BX112M4	160
42	741	1.4	23	13200				VF 130_23	P132 BE132MA6	152
42	750	2.0	23	13200				VF 150_23	P132 BE132MA6	160
45	635	1.1	64	12600				VF 130_64	P112 BE112M2	152
48	624	1.1	30	8000				W 110_30	P112 BE112M4 BX112M4	149
48	638	1.6	30	12600				VF 130_30	P112 BE112M4 BX112M4	152
48	646	2.1	30	14700				VF 150_30	P112 BE112M4 BX112M4	160
48	686	2.2	30	16000				VFR 150_30	P112 BE112M4 BX112M4	162
63	515	1.0	23	8000				W 110_23	P112 BE112M4 BX112M4	149
63	480	1.6	46	12600				VF 130_46	P112 BE112M2	152
64	514	1.7	23	12600				VF 130_23	P112 BE112M4 BX112M4	152
64	514	2.5	23	14700				VF 150_23	P112 BE112M4 BX112M4	160
72	454	1.3	20	8000				W 110_20	P112 BE112M4 BX112M4	149
73	452	2.0	20	12400				VF 130_20	P112 BE112M4 BX112M4	152
96	344	1.0	15	5410				W 86_15	P112 BE112M4 BX112M4	145
96	340	1.8	15	8000				W 110_15	P112 BE112M4 BX112M4	149
97	346	3.4	10	12700				VF 150_10	P132 BE132MA6	160
98	347	2.7	15	11400				VF 130_15	P112 BE112M4 BX112M4	152
144	238	1.0	10	2160				W 75_10	P112 BE112M4 BX112M4	141
144	238	1.2	10	4940				W 86_10	P112 BE112M4 BX112M4	145
144	235	2.3	10	7840				W 110_10	P112 BE112M4 BX112M4	149
146	237	3.3	10	10100				VF 130_10	P112 BE112M4 BX112M4	152
193	174	1.3	15	2400				W 75_15	P112 BE112M2	141
193	172	1.7	15	4820				W 86_15	P112 BE112M2	145
206	173	1.1	7	1900				W 75_7	P112 BE112M4 BX112M4	141
206	171	1.5	7	4490				W 86_7	P112 BE112M4 BX112M4	145
206	171	3.0	7	7040				W 110_7	P112 BE112M4 BX112M4	149
290	119	1.7	10	2210				W 75_10	P112 BE112M2	141
290	119	2.2	10	4320				W 86_10	P112 BE112M2	145
414	84	2.0	7	2010				W 75_7	P112 BE112M2	141
414	84	2.7	7	3890				W 86_7	P112 BE112M2	145



## 5.5 kW

n <sub>2</sub> min-1	M <sub>2</sub> Nm	S	i	R <sub>n2</sub> N								
					IE2	IE3		IE2	IE3			
2.4	9630	0.9	600	52000				VF/VF 130/250_600	P132	BE132S4	BX132S4	186
3.4	7714	1.2	280	52000				VF/VF 130/250_280	P160	BE160MA6		186
3.7	7295	0.9	400	34500				VF/VF 130/210_400	P132	BE132S4	BX132S4	180
3.7	7149	1.3	400	52000				VF/VF 130/250_400	P132	BE132S4	BX132S4	186
5.2	5311	1.2	280	34500				VF/VF 130/210_280	P132	BE132S4	BX132S4	180
5.2	5413	1.7	280	52000				VF/VF 130/250_280	P132	BE132S4	BX132S4	186
5.4	6029	1.1	180	52000				VFR 250_180	P160	BE160MA6		184
6.4	5024	1.0	150	34500				VFR 210_150	P160	BE160MA6		178
6.4	5105	1.3	150	52000				VFR 250_150	P160	BE160MA6		184
8.1	4202	1.0	180	34500				VFR 210_180	P132	BE132S4	BX132S4	178
8.1	4399	1.4	180	52000				VFR 250_180	P132	BE132S4	BX132S4	184
9.7	3296	0.9	100	33000				VF 210_100	P160	BE160MA6		176
9.7	3666	1.2	150	34500				VFR 210_150	P132	BE132S4	BX132S4	178
9.7	3666	1.8	150	52000				VFR 250_150	P132	BE132S4	BX132S4	184
12.1	2809	1.1	80	33000				VF 210_80	P160	BE160MA6		176
12.1	2895	1.7	80	50000				VF 250_80	P160	BE160MA6		182
12.2	3064	1.6	120	34500				VFR 210_120	P132	BE132S4	BX132S4	178
12.2	3108	2.3	120	52000				VFR 250_120	P132	BE132S4	BX132S4	184
14.6	2371	1.1	100	31500				VF 210_100	P132	BE132S4	BX132S4	176
14.6	2590	1.4	100	19500				VFR 185_100	P132	BE132S4	BX132S4	170
14.6	2480	1.5	100	47000				VF 250_100	P132	BE132S4	BX132S4	182
16.1	2301	1.1	60	19000				VF 185_60	P160	BE160MA6		168
16.1	2268	1.6	60	33000				VF 210_60	P160	BE160MA6		176
16.1	2334	2.4	60	50000				VF 250_60	P160	BE160MA6		182
16.2	2495	1.6	90	34500				VFR 210_90	P132	BE132S4	BX132S4	178
16.2	2561	2.3	90	52000				VFR 250_90	P132	BE132S4	BX132S4	184
18.3	2013	1.1	80	18000				VF 185_80	P132	BE132S4	BX132S4	168
18.3	2013	1.4	80	31500				VF 210_80	P132	BE132S4	BX132S4	176
18.3	2072	1.9	80	47000				VF 250_80	P132	BE132S4	BX132S4	182
19.5	2106	1.3	75	19500				VFR 185_75	P132	BE132S4	BX132S4	170
21.0	1839	0.9	46	15500				VF 150_46	P160	BE160MA6		160
21.4	1945	2.5	45	34500				VFR 210_45	P160	BE160MA6		178
21.4	1993	3.4	45	52000				VFR 250_45	P160	BE160MA6		184
24.1	1599	1.1	40	15500				VF 150_40	P160	BE160MA6		160
24.3	1620	1.4	60	18000				VF 185_60	P132	BE132S4	BX132S4	168
24.3	1598	1.9	60	31500				VF 210_60	P132	BE132S4	BX132S4	176
24.3	1751	2.7	60	34500				VFR 210_60	P132	BE132S4	BX132S4	178
24.3	1663	2.7	60	47000				VF 250_60	P132	BE132S4	BX132S4	182
24.3	1773	4.0	60	52000				VFR 250_60	P132	BE132S4	BX132S4	184
29.2	1430	1.3	50	15940				VFR 150_50	P132	BE132S4	BX132S4	162
29.2	1386	1.8	50	18000				VF 185_50	P132	BE132S4	BX132S4	168
29.2	1477	2.2	50	19500				VFR 185_50	P132	BE132S4	BX132S4	170
29.2	1386	2.4	50	31500				VF 210_50	P132	BE132S4	BX132S4	176
29.2	1386	3.2	50	47000				VF 250_50	P132	BE132S4	BX132S4	182
31	1292	1.2	46	14700				VF 150_46	P132	BE132S4	BX132S4	160
32	1248	1.0	30	13200				VF 130_30	P160	BE160MA6		152
32	1362	3.0	45	34500				VFR 210_45	P132	BE132S4	BX132S4	178
37	1109	1.0	40	12600				VF 130_40	P132	BE132S4	BX132S4	152
37	1123	1.4	40	14700				VF 150_40	P132	BE132S4	BX132S4	160
37	1138	2.3	40	18000				VF 185_40	P132	BE132S4	BX132S4	168
37	1138	3.1	40	31500				VF 210_40	P132	BE132S4	BX132S4	176
39	1101	1.5	38	15400				VFR 150_37.5	P132	BE132S4	BX132S4	162
39	1149	2.4	38	19500				VFR 185_37.5	P132	BE132S4	BX132S4	170
42	1006	1.0	23	13000				VF 130_23	P160	BE160MA6		152
42	1019	1.4	23	15300				VF 150_23	P160	BE160MA6		160
49	864	1.2	30	12600				VF 130_30	P132	BE132S4	BX132S4	152
49	875	1.6	30	14700				VF 150_30	P132	BE132S4	BX132S4	160
49	908	2.2	30	18000				VF 185_30	P132	BE132S4	BX132S4	168
49	908	3.4	30	31500				VF 210_30	P132	BE132S4	BX132S4	176
59	775	1.9	25	13400				VFR 150_25	P132	BE132S4	BX132S4	162
59	784	3.3	25	19500				VFR 185_25	P132	BE132S4	BX132S4	170
64	673	0.9	15	8000				W 110_15	P160	BE160MA6		149
64	696	1.3	23	12100				VF 130_23	P132	BE132S4	BX132S4	152
64	696	1.8	23	14000				VF 150_23	P132	BE132S4	BX132S4	160
73	605	0.9	20	8000				W 110_20	P132	BE132S4	BX132S4	149

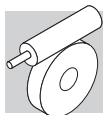

## 5.5 kW

n <sub>2</sub> min-1	M <sub>2</sub> Nm	S	i	R <sub>n2</sub> N							
					IE2	IE3	IE2	IE3			
73	613	1.5	20	11700			VF 130_20	P132	BE132S4	BX132S4	152
73	613	2.1	20	13500			VF 150_20	P132	BE132S4	BX132S4	160
97	454	1.3	15	8000			W 110_15	P132	BE132S4	BX132S4	149
97	471	2.0	15	12800			VF 130_15	P132	BE132S4	BX132S4	152
97	476	2.4	15	12400			VF 150_15	P132	BE132S4	BX132S4	160
127	354	1.9	23	10400			VF 130_23	P132	BE132SA2		152
127	354	2.7	23	11800			VF 150_23	P132	BE132SA2		160
146	313	1.8	10	7330			W 110_10	P132	BE132S4	BX132S4	149
146	321	2.5	10	9680			VF 130_10	P132	BE132S4	BX132S4	152
146	321	3.3	10	11000			VF 150_10	P132	BE132S4	BX132S4	160
195	234	2.3	15	7060			W 110_15	P132	BE132SA2		149
209	227	2.2	7	6600			W 110_7	P132	BE132S4	BX132S4	149
209	227	3.3	7	8650			VF 130_7	P132	BE132S4	BX132S4	152
293	160	3.0	10	6290			W 110_10	P132	BE132SA2		149
293	162	3.6	10	8110			VF 130_10	P132	BE132SA2		152
418	113	4.0	7	5640			W 110_7	P132	BE132SA2		149
418	114	4.9	7	7230			VF 130_7	P132	BE132SA2		152

## 7.5 kW

n <sub>2</sub> min-1	M <sub>2</sub> Nm	S	i	R <sub>n2</sub> N							
					IE2	IE3	IE2	IE2			
3.6	9554	0.9	400	52000			VF/VF 130/250_400	P132	BE132MA4	BX132MA4	186
5.2	7097	0.9	280	34500			VF/VF 130/210_280	P132	BE132MA4	BX132MA4	180
5.2	7233	1.2	280	52000			VF/VF 130/250_280	P132	BE132MA4	BX132MA4	186
6.4	7014	1.0	150	52000			VFR 250_150	P160	BE160MB6		184
8.0	5878	1.0	120	34500			VFR 210_120	P160	BE160MB6		178
8.1	5879	1.1	180	52000			VFR 250_180	P132	BE132MA4	BX132MA4	184
9.7	4676	1.0	100	50000			VF 250_100	P160	BE160MB6		182
9.7	4899	1.3	150	52000			VFR 250_150	P132	BE132MA4	BX132MA4	184
10.7	4809	0.9	90	34500			VFR 210_90	P160	BE160MB6		178
12.1	3978	1.3	80	50000			VF 250_80	P160	BE160MB6		182
12.1	4094	1.2	120	34500			VFR 210_120	P132	BE132MA4	BX132MA4	178
12.1	4153	1.7	120	52000			VFR 250_120	P132	BE132MA4	BX132MA4	184
14.6	3461	1.0	100	19500			VFR 185_100	P132	BE132MA4	BX132MA4	170
14.6	3314	1.1	100	47000			VF 250_100	P132	BE132MA4	BX132MA4	182
16.1	3117	1.2	60	33000			VF 210_60	P160	BE160MB6		176
16.2	3334	1.2	90	34500			VFR 210_90	P132	BE132MA4	BX132MA4	178
16.2	3422	1.7	90	52000			VFR 250_90	P132	BE132MA4	BX132MA4	184
18.2	2691	1.1	80	31500			VF 210_80	P132	BE132MA4	BX132MA4	176
18.2	2769	1.4	80	47000			VF 250_80	P132	BE132MA4	BX132MA4	182
19.4	2815	1.0	75	19500			VFR 185_75	P132	BE132MA4	BX132MA4	170
21.4	2672	1.8	45	34500			VFR 210_45	P160	BE160MB6		178
21.4	2739	2.5	45	52000			VFR 250_45	P160	BE160MB6		184
24.3	2164	1.0	60	18000			VF 185_60	P132	BE132MA4	BX132MA4	168
24.3	2135	1.4	60	31500			VF 210_60	P132	BE132MA4	BX132MA4	176
24.3	2340	2.0	60	31500			VFR 210_60	P132	BE132MA4	BX132MA4	178
24.3	2223	2.0	60	47000			VF 250_60	P132	BE132MA4	BX132MA4	182
24.3	2369	3.0	60	52000			VFR 250_60	P132	BE132MA4	BX132MA4	184
29.1	1911	1.0	50	14100			VFR 150_50	P132	BE132MA4	BX132MA4	162
29.1	1852	1.3	50	18000			VF 185_50	P132	BE132MA4	BX132MA4	168
29.1	1974	1.6	50	19500			VFR 185_50	P132	BE132MA4	BX132MA4	170
29.1	1852	1.7	50	31500			VF 210_50	P132	BE132MA4	BX132MA4	176
29.1	1852	2.4	50	47000			VF 250_50	P132	BE132MA4	BX132MA4	182
31	1727	0.9	46	14700			VF 150_46	P132	BE132MA4	BX132MA4	160
32	1821	2.2	45	34500			VFR 210_45	P132	BE132MA4	BX132MA4	178
32	1842	3.5	45	48800			VFR 250_45	P132	BE132MA4	BX132MA4	184
36	1501	1.0	40	14700			VF 150_40	P132	BE132MA4	BX132MA4	160
36	1521	1.7	40	18000			VF 185_40	P132	BE132MA4	BX132MA4	168
36	1521	2.3	40	31500			VF 210_40	P132	BE132MA4	BX132MA4	176
36	1541	3.2	40	47000			VF 250_40	P132	BE132MA4	BX132MA4	182
38	1471	1.1	38	13200			VFR 150_37.5	P132	BE132MA4	BX132MA4	162
38	1536	1.8	38	18300			VFR 185_37.5	P132	BE132MA4	BX132MA4	170
49	1155	0.9	30	11900			VF 130_30	P132	BE132MA4	BX132MA4	152
49	1170	1.1	30	14200			VF 150_30	P132	BE132MA4	BX132MA4	160
49	1214	1.6	30	18000			VF 185_30	P132	BE132MA4	BX132MA4	168
49	1214	2.6	30	31500			VF 210_30	P132	BE132MA4	BX132MA4	176



## 7.5 kW





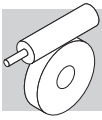

n <sub>2</sub> min-1	M <sub>2</sub> Nm	S	i	R <sub>n2</sub> N							
					IE2	IE3		IE2	IE3		
49	1257	3.1	30	33400			VFR 210_30	P132	BE132MA4	BX132MA4	178
49	1228	3.3	30	4440			VF 250_30	P132	BE132MA4	BX132MA4	182
59	1036	1.4	25	11000			VFR 150_25	P132	BE132MA4	BX132MA4	162
59	1048	2.4	25	16700			VFR 185_25	P132	BE132MA4	BX132MA4	170
64	931	0.9	23	11200			VF 130_23	P132	BE132MA4	BX132MA4	152
64	931	1.3	23	13200			VF 150_23	P132	BE132MA4	BX132MA4	160
64	958	2.3	15	16700			VF 185_15	P160	BE160MB6		168
73	819	1.1	20	10800			VF 130_20	P132	BE132MA4	BX132MA4	152
73	819	1.6	20	12700			VF 150_20	P132	BE132MA4	BX132MA4	160
97	614	1.0	15	7370			W 110_15	P132	BE132MA4	BX132MA4	149
97	629	1.4	15	10200			VF 130_15	P132	BE132MA4	BX132MA4	152
97	636	1.8	15	11700			VF 150_15	P132	BE132MA4	BX132MA4	160
127	479	1.4	23	9900			VF 130_23	P132	BE132SB2		152
127	479	2.0	23	11400			VF 150_23	P132	BE132SB2		160
138	462	2.5	7	10200			VF 150_7	P160	BE160MB6		160
146	424	1.3	10	6720			W 110_10	P132	BE132MA4	BX132MA4	149
146	429	1.8	10	9150			VF 130_10	P132	BE132MA4	BX132MA4	152
146	429	2.4	10	10500			VF 150_10	P132	BE132MA4	BX132MA4	160
195	320	1.7	15	6660			W 110_15	P132	BE132SB2		149
208	304	1.6	7	6100			W 110_7	P132	BE132MA4	BX132MA4	149
208	304	2.4	7	8210			VF 130_7	P132	BE132MA4	BX132MA4	152
208	307	3.3	7	9400			VF 150_7	P132	BE132MA4	BX132MA4	160
293	215	2.2	10	5980			W 110_10	P132	BE132SB2		149
293	217	2.8	10	7840			VF 130_10	P132	BE132SB2		152
418	153	2.9	7	5380			W 110_7	P132	BE132SB2		149
418	154	3.6	7	7010			VF 130_7	P132	BE132SB2		152

## 9.2 kW







n <sub>2</sub> min-1	M <sub>2</sub> Nm	S	i	R <sub>n2</sub> N							
					IE2	IE3		IE2	IE3		
5.1	9054	1.0	280	52000			VF/VF 130/250_280	P132	BE132MB4		186
9.7	6132	1.1	150	52000			VFR 250_150	P132	BE132MB4	BX160MA4	184
12.1	5198	1.3	120	52000			VFR 250_120	P132	BE132MB4	BX160MA4	184
14.5	4149	0.9	100	47000			VF 250_100	P132	BE132MB4	BX160MA4	182
16.1	4173	1.0	90	34500			VFR 210_90	P132	BE132MB4	BX160MA4	178
16.1	4283	1.4	90	52000			VFR 250_90	P132	BE132MB4	BX160MA4	184
18.1	3368	0.9	80	31500			VF 210_80	P132	BE132MB4	BX160MA4	176
18.1	3466	1.1	80	47000			VF 250_80	P132	BE132MB4	BX160MA4	182
24.2	2672	1.1	60	31500			VF 210_60	P132	BE132MB4	BX160MA4	176
24.2	2929	1.6	60	34500			VFR 210_60	P132	BE132MB4	BX160MA4	178
24.2	2782	1.6	60	47000			VF 250_60	P132	BE132MB4	BX160MA4	182
24.2	2965	2.4	60	51900			VFR 250_60	P132	BE132MB4	BX160MA4	184
29.0	2319	1.1	50	18000			VF 185_50	P132	BE132MB4	BX160MA4	168
29.0	2471	1.3	50	18600			VFR 185_50	P132	BE132MB4		170
29.0	2319	1.4	50	31500			VF 210_50	P132	BE132MB4	BX160MA4	176
29.0	2319	1.9	50	47000			VF 250_50	P132	BE132MB4	BX160MA4	182
32	2279	1.8	45	34500			VFR 210_45	P132	BE132MB4	BX160MA4	178
32	2306	2.8	45	48000			VFR 250_45	P132	BE132MB4	BX160MA4	184
36	1904	1.4	40	18000			VF 185_40	P132	BE132MB4	BX160MA4	168
36	1904	1.8	40	31500			VF 210_40	P132	BE132MB4	BX160MA4	176
36	1928	2.5	40	47000			VF 250_40	P132	BE132MB4	BX160MA4	182
38	1884	0.9	38	11900			VFR 150_37.5	P132	BE132MB4		162
38	1922	1.5	38	17200			VFR 185_37.5	P132	BE132MB4		170
48	1464	0.9	30	11300			VF 150_30	P132	BE132MB4	BX160MA4	160
48	1519	1.3	30	17900			VF 185_30	P132	BE132MB4	BX160MA4	168
48	1519	2.0	30	31500			VF 210_30	P132	BE132MB4	BX160MA4	176
48	1574	2.4	30	32600			VFR 210_30	P132	BE132MB4	BX160MA4	178
48	1538	2.6	30	43900			VF 250_30	P132	BE132MB4	BX160MA4	182
48	1574	3.8	30	42800			VFR 250_30	P132	BE132MB4	BX160MA4	184
58	1297	1.2	25	11200			VFR 150_25	P132	BE132MB4		162
58	1312	2.0	25	15800			VFR 185_25	P132	BE132MB4		170
63	1165	1.1	23	12500			VF 150_23	P132	BE132MB4	BX160MA4	160
73	1025	0.9	20	10100			VF 130_20	P132	BE132MB4	BX160MA4	152
73	1025	1.3	20	12100			VF 150_20	P132	BE132MB4		160
73	1037	3.0	20	30400			VF 210_20	P132	BE132MB4	BX160MA4	176
97	787	1.2	15	9560			VF 130_15	P132	BE132MB4		152
97	796	1.4	15	11200			VF 150_15	P132	BE132MB4	BX160MA4	160
127	601	1.1	23	9510			VF 130_23	P132	BE132MB2		152









## 9.2 kW

n <sub>2</sub> min-1	M <sub>2</sub> Nm	S	i	R <sub>n2</sub> N	  			  				
					IE2	IE3		IE2	IE3			
127	601	1.6	23	11000				VF 150_23	P132	BE132MB2		160
145	531	1.0	10	6210				W 110_10	P132	BE132MB4		149
145	537	1.5	10	8690				VF 130_10	P132	BE132MB4	BX160MA4	152
145	537	2.0	10	16100				VF 150_10	P132	BE132MB4		160
195	396	1.4	15	6320				W 110_15	P132	BE132MB2		149
207	380	1.3	7	5670				W 110_7	P132	BE132MB4		149
207	380	1.9	7	7820				VF 130_7	P132	BE132MB4		152
207	384	2.6	7	9030				VF 150_7	P132	BE132MB4		BX160MA4
292	271	1.8	10	5720				W 110_10	P132	BE132MB2		149
292	274	2.2	10	7620				VF 130_10	P132	BE132MB2		152
292	274	2.9	10	8690				VF 150_10	P132	BE132MB2		160
417	192	2.3	7	5170				W 110_7	P132	BE132MB2		149
417	194	2.9	7	6820				VF 130_7	P132	BE132MB2		152

## 11 kW

n <sub>2</sub> min-1	M <sub>2</sub> Nm	S	i	R <sub>n2</sub> N	  			  				
					IE2	IE3		IE2	IE2			
12.3	6130	1.1	120	52000				VFR 250_120	P160	BE160M4	BX160MB4	184
16.3	5051	1.2	90	52000				VFR 250_90	P160	BE160M4	BX160MB4	184
18.4	4087	0.9	80	47000				VF 250_80	P160	BE160M4	BX160MB4	182
24.5	3151	0.9	60	31500				VF 210_60	P160	BE160M4	BX160MB4	176
24.5	3454	1.3	60	34500				VFR 210_60	P160	BE160M4	BX160MB4	178
24.5	3281	1.4	60	47000				VF 250_60	P160	BE160M4	BX160MB4	182
24.5	3496	2.0	60	50900				VFR 250_60	P160	BE160M4	BX160MB4	184
29.4	2734	1.2	50	31500				VF 210_50	P160	BE160M4	BX160MB4	176
29.4	2734	1.6	50	47000				VF 250_50	P160	BE160M4	BX160MB4	182
33	2688	1.5	45	34500				VFR 210_45	P160	BE160M4	BX160MB4	178
33	2720	2.3	45	47100				VFR 250_45	P160	BE160M4	BX160MB4	184
37	2245	1.2	40	18500				VF 185_40	P160	BE160M4	BX160MB4	168
37	2245	1.5	40	31500				VF 210_40	P160	BE160M4	BX160MB4	176
37	2273	2.1	40	47000				VF 250_40	P160	BE160M4	BX160MB4	182
49	1791	1.1	30	17200				VF 185_30	P160	BE160M4	BX160MB4	168
49	1791	1.7	30	31500				VF 210_30	P160	BE160M4	BX160MB4	176
49	1856	2.0	30	31800				VFR 210_30	P160	BE160M4	BX160MB4	178
49	1813	2.2	30	43400				VF 250_30	P160	BE160M4	BX160MB4	182
49	1856	3.2	30	42100				VFR 250_30	P160	BE160M4	BX160MB4	184
74	1209	1.1	20	11400				VF 150_20	P160	BE160M4	BX160MB4	160
74	1223	1.8	20	15600				VF 185_20	P160	BE160M4	BX160MB4	168
74	1223	2.5	20	30000				VF 210_20	P160	BE160M4	BX160MB4	176
98	939	1.2	15	10600				VF 150_15	P160	BE160M4	BX160MB4	160
98	950	1.9	15	14200				VF 185_15	P160	BE160M4	BX160MB4	168
98	950	3.0	15	27700				VF 210_15	P160	BE160M4	BX160MB4	176
147	630	2.7	20	13300				VF 185_20	P160	BE160MA2		168
147	633	1.6	10	9670				VF 150_10	P160	BE160M4	BX160MB4	160
196	478	2.9	15	12200				VF 185_15	P160	BE160MA2		168
210	454	2.2	7	8660				VF 150_7	P160	BE160M4	BX160MB4	160
294	323	2.4	10	8440				VF 150_10	P160	BE160MA2		160
420	228	3.3	7	7530				VF 150_7	P160	BE160MA2		160







## 15 kW

n <sub>2</sub> min-1	M <sub>2</sub> Nm	S	i	R <sub>n2</sub> N	  			  				
					IE2	IE3		IE2	IE3			
24.5	4474	1.0	60	47000				VF 250_60	P160	BE160L4	BX160LA4	182
24.5	4768	1.5	60	48700				VFR 250_60	P160	BE160L4	BX160LA4	184
29.4	3728	0.9	50	31500				VF 210_50	P160	BE160L4	BX160LA4	176
29.4	3728	1.2	50	47000				VF 250_50	P160	BE160L4	BX160LA4	182
32	3665	1.1	45	33200				VFR 210_45	P160	BE160L4	BX160LA4	178
32	3709	1.7	45	45200				VFR 250_45	P160	BE160L4	BX160LA4	184
37	3061	0.9	40	16600				VF 185_40	P160	BE160L4	BX160LA4	168
37	3061	1.1	40	31500				VF 210_40	P160	BE160L4	BX160LA4	176
37	3100	1.5	40	45900				VF 250_40	P160	BE160L4	BX160LA4	182
49	2443	1.2	30	31500				VF 210_30	P160	BE160L4	BX160LA4	176



















## 15 kW

n <sub>2</sub> min-1	M <sub>2</sub> Nm	S	i	R <sub>n2</sub> N	 			  				
					IE2	IE3		IE2	IE3	IEC		
49	2531	1.5	30	30000				VFR 210_30	P160	BE160L4	BX160LA4	178
49	2473	1.6	30	42400				VF 250_30	P160	BE160L4	BX160LA4	182
49	2531	2.4	30	40600				VFR 250_30	P160	BE160L4	BX160LA4	184
74	1668	1.4	20	14300				VF 185_20	P160	BE160L4	BX160LA4	168
74	1668	1.9	20	29100				VF 210_20	P160	BE160L4	BX160LA4	176
74	1688	2.6	20	38100				VF 250_20	P160	BE160L4	BX160LA4	182
98	1280	0.9	15	9360				VF 150_15	P160	BE160L4	BX160LA4	160
98	1295	1.4	15	13200				VF 185_15	P160	BE160L4	BX160LA4	168
98	1295	2.2	15	27000				VF 210_15	P160	BE160L4	BX160LA4	176
98	1295	3.1	15	35100				VF 250_15	P160	BE160L4	BX160LA4	182
147	855	2.0	20	12700				VF 185_20	P160	BE160MB2		168
147	863	1.2	10	8720				VF 150_10	P160	BE160L4	BX160LA4	160
147	873	3.0	10	24000				VF 210_10	P160	BE160L4	BX160LA4	176
196	649	2.1	15	11600				VF 185_15	P160	BE160MB2		168
196	649	3.3	15	22700				VF 210_15	P160	BE160MB2		176
210	618	1.6	7	7840				VF 150_7	P160	BE160L4	BX160LA4	160
294	437	1.8	10	7960				VF 150_10	P160	BE160MB2		160
420	309	2.4	7	7120				VF 150_7	P160	BE160MB2		160

## 18.5 kW





n <sub>2</sub> min-1	M <sub>2</sub> Nm	S	i	R <sub>n2</sub> N	 			  				
					IE2	IE3		IE2	IE3	IEC		
29.4	4560	1.0	50	47000				VF 250_50	P180	BE180M4	BX180M4	182
37	3745	0.9	40	31500				VF 210_40	P180	BE180M4	BX180M4	176
37	3792	1.3	40	44900				VF 250_40	P180	BE180M4	BX180M4	182
49	2988	1.0	30	31200				VF 210_30	P180	BE180M4	BX180M4	176
49	3024	1.3	30	41500				VF 250_30	P180	BE180M4	BX180M4	182
74	2040	1.1	20	13200				VF 185_20	P180	BE180M4	BX180M4	168
74	2040	1.5	20	28300				VF 210_20	P180	BE180M4	BX180M4	176
74	2064	2.1	20	37400				VF 250_20	P180	BE180M4	BX180M4	182
98	1584	1.2	15	12200				VF 185_15	P180	BE180M4	BX180M4	168
98	1584	1.8	15	26200				VF 210_15	P180	BE180M4	BX180M4	176
98	1584	2.5	15	34500				VF 250_15	P180	BE180M4	BX180M4	182
147	1068	1.7	10	11400				VF 185_10	P180	BE180M4	BX180M4	168
147	1068	2.5	10	23400				VF 210_10	P180	BE180M4	BX180M4	176
147	1080	3.4	10	37800				VF 250_10	P180	BE180M4	BX180M4	182
196	805	1.1	15	8260				VF 150_15	P160	BE160L2		160
210	756	2.3	7	10100				VF 185_7	P180	BE180M4	BX180M4	168
210	756	3.0	7	21200				VF 210_7	P180	BE180M4	BX180M4	176
295	543	1.5	10	7550				VF 150_10	P160	BE160L2		160
421	384	2.0	7	6760				VF 150_7	P160	BE160L2		160

## 22 kW





n <sub>2</sub> min-1	M <sub>2</sub> Nm	S	i	R <sub>n2</sub> N	 			  				
					IE2	IE3		IE2	IE3	IEC		
37	4501	1.1	40	43900				VF 250_40	P180	BE180L4	BX180L4	182
49	3546	0.9	30	30200				VF 210_30	P180	BE180L4	BX180L4	176
49	3589	1.1	30	44700				VF 250_30	P180	BE180L4	BX180L4	182
74	2421	0.9	20	12200				VF 185_20	P180	BE180L4	BX180L4	168
74	2421	1.3	20	27500				VF 210_20	P180	BE180L4	BX180L4	176
74	2450	1.8	20	36700				VF 250_20	P180	BE180L4	BX180L4	182
99	1880	1.0	15	11300				VF 185_15	P180	BE180L4	BX180L4	168
99	1880	1.5	15	25500				VF 210_15	P180	BE180L4	BX180L4	176
99	1880	2.1	15	33900				VF 250_15	P180	BE180L4	BX180L4	182
148	1267	1.4	10	10700				VF 185_10	P180	BE180L4	BX180L4	168
148	1267	2.1	10	22900				VF 210_10	P180	BE180L4	BX180L4	176
148	1282	2.9	10	30300				VF 250_10	P180	BE180L4	BX180L4	182
210	898	1.9	7	9510				VF 185_7	P180	BE180L4	BX180L4	168
210	898	2.5	7	20800				VF 210_7	P180	BE180L4	BX180L4	176
210	908	3.5	7	27500				VF 250_7	P180	BE180L4	BX180L4	182







## 30 kW

<b>n<sub>2</sub></b> min <sup>-1</sup>	<b>M<sub>2</sub></b> Nm	<b>S</b>	<b>i</b>	<b>R<sub>n2</sub></b> N	 IE...	 IEC	 IEC	 IEC	 IEC
147	1754	2,1	10	29200		VF 250_10	P200	IEC200L4	182
210	1228	1,9	7	19700		VF 210_7	P200	IEC200L4	176
210	1242	2,6	7	26600		VF 250_7	P200	IEC200L4	182
295	874	2,3	10	19000		VF 210_10	P200	IEC200LA2	176
421	619	2,8	7	17200		VF 210_7	P200	IEC200LA2	176

## 37 kW

<b>n<sub>2</sub></b> min <sup>-1</sup>	<b>M<sub>2</sub></b> Nm	<b>S</b>	<b>i</b>	<b>R<sub>n2</sub></b> N	 IE...	 IEC	 IEC	 IEC	 IEC
74	4107	1,1	20	22800		VF 250_20	P225	IEC225S4	182
99	3152	0,9	15	22600		VF 210_15	P225	IEC225S4	176
99	3152	1,3	15	31400		VF 250_15	P225	IEC225S4	182
148	2125	1,2	10	20500		VF 210_10	P225	IEC225S4	176
148	2149	1,7	10	28300		VF 250_10	P225	IEC225S4	182
211	1504	1,5	7	18800		VF 210_7	P225	IEC225S4	176
211	1521	2,1	7	25800		VF 250_7	P225	IEC225S4	182
296	1074	1,9	10	18400		VF 210_10	P200	IEC200L2	176
296	1086	2,6	10	24500		VF 250_10	P200	IEC200L2	182
423	760	2,3	7	16800		VF 210_7	P200	IEC200L2	176

## 45 kW

<b>n<sub>2</sub></b> min <sup>-1</sup>	<b>M<sub>2</sub></b> Nm	<b>S</b>	<b>i</b>	<b>R<sub>n2</sub></b> N	 IE...	 IEC	 IEC	 IEC	 IEC
74	4994	0,9	20	32300		VF 250_20	P225	IEC225M4	182
99	3833	1	15	30100		VF 250_15	P225	IEC225M4	182
148	2584	1	10	19200		VF 210_10	P225	IEC225M4	176
148	2613	1,4	10	27300		VF 250_10	P225	IEC225M4	182
211	1829	1,3	7	17800		VF 210_7	P225	IEC225M4	176
211	1850	1,7	7	25000		VF 250_7	P225	IEC225M4	182
296	1307	1,5	10	17800		VF 210_10	P200	IEC225M2	176
296	1321	2,1	10	24000		VF 250_10	P200	IEC225M2	182
423	925	1,9	7	16200		VF 210_7	P200	IEC225M2	176
423	935	2,6	7	21800		VF 250_7	P200	IEC225M2	182

I dati tecnici riportati sono da considerarsi indicativi, le configurazioni dovrebbero trovare riscontro presso i produttori dei motori elettrici per le potenze superiori ai 22 kW.

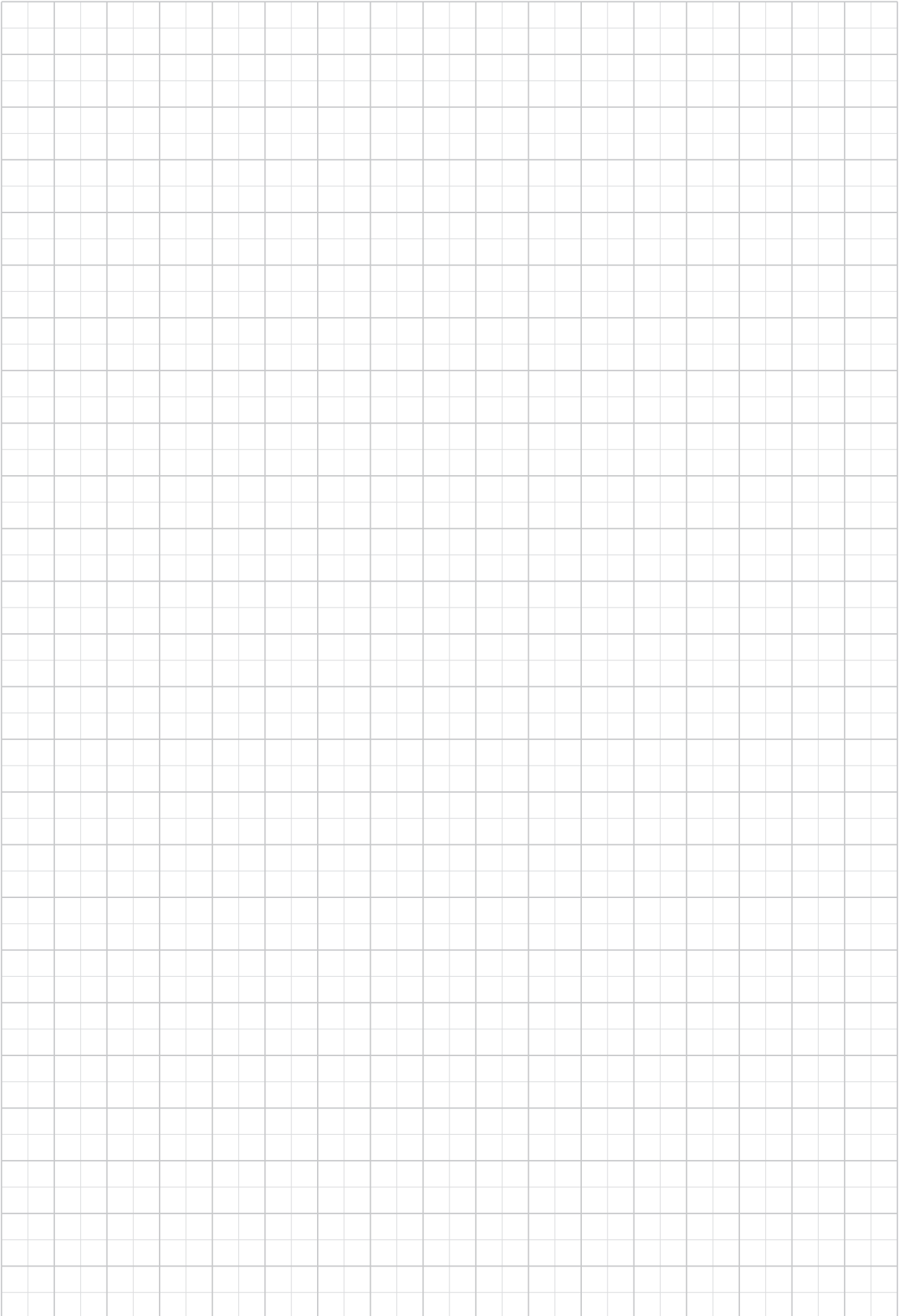
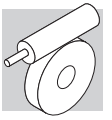



## 22 TABELLE DATI TECNICI RIDUTTORI

### VF 27

13 Nm

	i	$\eta_s$ %	$n_2$	$M_{n2}$	$P_{n1}$	$R_{n1}$	$R_{n2}$	$\eta_d$	$n_2$	$M_{n2}$	$P_{n1}$	$R_{n1}$	$R_{n2}$	$\eta_d$		
			min <sup>-1</sup>	Nm	kW	N	N	%	min <sup>-1</sup>	Nm	kW	N	N	%		
			$n_1 = 2800 \text{ min}^{-1}$						$n_1 = 1400 \text{ min}^{-1}$							
VF 27	VF 27_7	7	67	400	7	0.34	—	330	86	200	9	0.23	35	410	83	187
	VF 27_10	10	62	280	7	0.24	—	400	84	140	9	0.16	30	500	80	
	VF 27_15	15	54	187	7	0.17	—	480	79	93	9	0.12	—	600	75	
	VF 27_20	20	49	140	7	0.14	—	540	76	70	9	0.09	—	600	71	
	VF 27_30	30	38	93	7	0.10	—	600	69	47	9	0.07	—	600	62	
	VF 27_40	40	33	70	7	0.08	—	600	64	35	9	0.06	—	600	57	
	VF 27_60	60	26	47	7	0.06	—	600	56	23.3	9	0.04	—	600	49	
	VF 27_70	70	24	40	7	0.06	—	600	53	20.0	9	0.04	—	600	45	
				$n_1 = 900 \text{ min}^{-1}$						$n_1 = 500 \text{ min}^{-1}$						
	VF 27_7	7	67	129	10	0.17	90	480	81	71	11	0.11	90	600	79	187
	VF 27_10	10	62	90	11	0.13	20	570	78	50	12	0.08	90	600	76	
	VF 27_15	15	54	60	11	0.09	—	600	72	33	12	0.06	90	600	69	
	VF 27_20	20	49	45	11	0.08	—	600	68	25.0	12	0.05	90	600	65	
	VF 27_30	30	38	30.0	11	0.06	—	600	59	16.7	13	0.04	—	600	55	
VF 27_40	40	33	22.5	11	0.05	—	600	54	12.5	13	0.04	—	600	50		
VF 27_60	60	26	15.0	11	0.04	—	600	45	8.3	12	0.02	—	600	41		
VF 27_70	70	24	12.9	10	0.03	—	600	42	7.1	11	0.02	—	600	38		

### VF 30

24 Nm

	i	$\eta_s$ %	$n_2$	$M_{n2}$	$P_{n1}$	$R_{n1}$	$R_{n2}$	$\eta_d$	$n_2$	$M_{n2}$	$P_{n1}$	$R_{n1}$	$R_{n2}$	$\eta_d$		
			min <sup>-1</sup>	Nm	kW	N	N	%	min <sup>-1</sup>	Nm	kW	N	N	%		
			$n_1 = 2800 \text{ min}^{-1}$						$n_1 = 1400 \text{ min}^{-1}$							
VF 30	VF 30_7	7	69	400	12	0.58	120	510	87	200	16	0.41	140	630	84	188
	VF 30_10	10	64	280	12	0.41	70	620	85	140	16	0.30	80	770	81	
	VF 30_15	15	56	187	14	0.34	—	720	81	93	18	0.24	—	910	76	
	VF 30_20	20	51	140	14	0.26	—	820	78	70	18	0.19	—	1030	73	
	VF 30_30	30	41	93	15	0.21	—	960	71	47	20	0.15	—	1200	65	
	VF 30_40	40	36	70	14	0.16	—	1090	66	35	19	0.12	—	1360	60	
	VF 30_60	60	29	47	14	0.12	—	1270	59	23.3	19	0.09	—	1590	51	
	VF 30_70	70	26	40	11	0.08	—	1380	55	20.0	15	0.07	—	1600	48	
				$n_1 = 900 \text{ min}^{-1}$						$n_1 = 500 \text{ min}^{-1}$						
	VF 30_7	7	69	129	18	0.30	150	730	82	71	20	0.19	150	920	81	188
	VF 30_10	10	64	90	18	0.22	150	900	79	50	20	0.14	150	1120	77	
	VF 30_15	15	56	60	20	0.17	—	1060	74	33	22	0.11	150	1320	71	
	VF 30_20	20	51	45	20	0.14	—	1200	70	25.0	22	0.09	150	1490	67	
	VF 30_30	30	41	30	22	0.12	—	1400	61	16.7	24	0.07	—	1700	58	
VF 30_40	40	36	23	20	0.09	—	1590	56	12.5	22	0.06	—	1700	53		
VF 30_60	60	29	15	20	0.07	—	1650	48	8.3	22	0.05	—	1700	44		
VF 30_70	70	26	13	17	0.05	—	1700	45	7.0	19	0.04	—	1700	41		

(-) Interpellare il ns. servizio tecnico comunicando i dati relativi al carico radiale (senso di rotazione, orientamento, posizione)



## VF 44 - VF/VF 30/44

**55 Nm**

		i	η <sub>s</sub> %	n <sub>1</sub> = 2800 min <sup>-1</sup>						n <sub>1</sub> = 1400 min <sup>-1</sup>						
				n <sub>2</sub> min <sup>-1</sup>	M <sub>n2</sub> Nm	P <sub>n1</sub> kW	R <sub>n1</sub> N	R <sub>n2</sub> N	η <sub>d</sub> %	n <sub>2</sub> min <sup>-1</sup>	M <sub>n2</sub> Nm	P <sub>n1</sub> kW	R <sub>n1</sub> N	R <sub>n2</sub> N	η <sub>d</sub> %	
				<b>VF 44</b>	<b>VF 44_7</b>	7	71	400	22	1.1	220	950	88	200	29	
<b>VF 44_10</b>	10	66	280	22	0.74	220	1150	87	140	29	0.51	220	1430	84		
<b>VF 44_14</b>	14	60	200	22	0.55	220	1340	84	100	29	0.37	220	1680	81		
<b>VF 44_20</b>	20	55	140	29	0.52	220	1490	81	70	39	0.37	220	1860	77		
<b>VF 44_28</b>	28	45	100	29	0.40	220	1710	76	50	39	0.29	220	2140	71		
<b>VF 44_35</b>	35	42	80	29	0.33	220	1870	73	40	39	0.25	220	2300	68		
<b>VF 44_46</b>	46	37	61	29	0.27	220	2080	69	30.0	39	0.19	220	2300	63		
<b>VF 44_60</b>	60	32	47	29	0.22	220	2290	65	23.3	39	0.16	220	2300	58		
<b>VF 44_70</b>	70	30	40	22	0.15	220	2300	62	20.0	29	0.11	220	2300	55		
<b>VF 44_100</b>	100	24	28	21	0.11	220	2300	55	14.0	28	0.09	220	2300	47		
				n <sub>1</sub> = 900 min <sup>-1</sup>						n <sub>1</sub> = 500 min <sup>-1</sup>						
	<b>VF 44_7</b>	7	71	129	39	0.63	220	1300	85	71	45	0.41	220	1610	83	188
	<b>VF 44_10</b>	10	66	90	39	0.45	220	1610	82	50	45	0.29	220	1980	80	
	<b>VF 44_14</b>	14	60	64	39	0.34	220	1890	78	36	50	0.25	220	2280	76	
	<b>VF 44_20</b>	20	55	45	45	0.29	220	2160	74	25.0	50	0.18	220	2500	72	
	<b>VF 44_28</b>	28	45	32	49	0.24	220	2300	67	17.9	55	0.16	220	2500	64	
	<b>VF 44_35</b>	35	42	25.7	49	0.20	220	2300	64	14.3	55	0.14	220	2500	60	
	<b>VF 44_46</b>	46	37	19.6	49	0.17	220	2300	59	10.9	50	0.10	220	2500	55	
	<b>VF 44_60</b>	60	32	15.0	45	0.13	200	2300	54	8.3	50	0.09	220	2500	50	
	<b>VF 44_70</b>	70	30	12.9	39	0.10	220	2300	51	7.1	45	0.07	220	2500	47	
	<b>VF 44_100</b>	100	24	9.0	30	0.06	220	2300	43	5.0	32	0.04	220	2500	39	

**70 Nm**

		i	η <sub>s</sub> %	n <sub>1</sub> = 1400 min <sup>-1</sup>						n <sub>1</sub> = 900 min <sup>-1</sup>						
				n <sub>2</sub> min <sup>-1</sup>	M <sub>n2</sub> Nm	P <sub>n1</sub> kW	R <sub>n1</sub> N	R <sub>n2</sub> N	η <sub>d</sub> %	n <sub>2</sub> min <sup>-1</sup>	M <sub>n2</sub> Nm	P <sub>n1</sub> kW	R <sub>n1</sub> N	R <sub>n2</sub> N	η <sub>d</sub> %	
				<b>VF/VF 30/44</b>	<b>VF/VF 30/44_245</b>	245	29	5.7	60	0.09	140	2500	40	3.7	70	
<b>VF/VF 30/44_350</b>	350	27	4.0	60	0.07	80	2500	36	2.6	70	0.05	150	2500	38		
<b>VF/VF 30/44_420</b>	420	25	3.3	60	0.06	—	2500	35	2.1	70	0.04	—	2500	39		
<b>VF/VF 30/44_560</b>	560	23	2.5	60	0.05	—	2500	31	1.6	70	0.04	—	2500	29		
<b>VF/VF 30/44_700</b>	700	21	2.0	60	0.04	—	2500	31	1.3	70	0.03	—	2500	31		
<b>VF/VF 30/44_840</b>	840	18	1.7	60	0.04	—	2500	26	1.1	70	0.03	—	2500	26		
<b>VF/VF 30/44_1120</b>	1120	16	1.3	60	0.03	—	2500	26	0.80	70	0.02	—	2500	29		
<b>VF/VF 30/44_1680</b>	1680	13	0.83	60	0.02	—	2500	26	0.54	70	0.02	—	2500	20		
<b>VF/VF 30/44_2100</b>	2100	12	0.67	60	0.02	—	2500	21	0.43	70	0.02	—	2500	16		

(-) Interpellare il ns. servizio tecnico comunicando i dati relativi al carico radiale (senso di rotazione, orientamento, posizione)



## VF 49 - VFR 49

88 Nm

		i	η <sub>s</sub> %	n <sub>1</sub> = 2800 min <sup>-1</sup>						n <sub>1</sub> = 1400 min <sup>-1</sup>						
				n <sub>2</sub> min <sup>-1</sup>	M <sub>n2</sub> Nm	P <sub>n1</sub> kW	R <sub>n1</sub> N	R <sub>n2</sub> N	η <sub>d</sub> %	n <sub>2</sub> min <sup>-1</sup>	M <sub>n2</sub> Nm	P <sub>n1</sub> kW	R <sub>n1</sub> N	R <sub>n2</sub> N	η <sub>d</sub> %	
				VF 49												
				400	41	2.0	400	950	88	200	54	1.3	400	1170	86	188
				280	44	1.5	400	1140	86	140	59	1.0	400	1410	84	
				200	49	1.2	400	1310	84	100	65	0.90	400	1630	81	
				156	44	0.87	400	1520	82	78	59	0.60	400	1890	78	
				117	47	0.73	400	1670	79	58	63	0.50	400	2110	75	
				100	56	0.78	400	1740	75	50	74	0.55	400	2170	71	
				78	52	0.59	400	1970	72	39	69	0.42	400	2460	67	
				62	49	0.46	400	2180	69	31	65	0.33	400	2725	63	
				47	44	0.34	400	2480	64	23.3	59	0.25	400	3100	58	
				40	41	0.28	400	2650	61	20.0	55	0.21	400	3150	54	
				35	41	0.25	400	2780	59	17.5	54	0.19	400	3150	52	
				28.0	37	0.20	400	3050	54	14.0	49	0.13	400	3150	47	
				n <sub>1</sub> = 900 min <sup>-1</sup>						n <sub>1</sub> = 500 min <sup>-1</sup>						
				129	61	0.97	400	1370	85	71	74	0.67	400	1670	83	188
				90	64	0.75	400	1670	82	50	74	0.49	400	2060	80	
				64	71	0.61	400	1920	78	36	78	0.39	400	2400	75	
				50	68	0.47	400	2190	75	27.8	74	0.30	400	2730	72	
				38	68	0.36	400	2480	71	20.8	74	0.24	400	3090	68	
				32	82	0.41	400	2540	67	17.9	88	0.26	400	3180	63	
				25.0	75	0.31	400	2880	63	13.9	80	0.20	400	3450	59	
				20.0	71	0.25	400	3190	59	11.1	78	0.17	400	3450	55	
				15.0	64	0.19	400	3300	53	8.3	69	0.12	400	3450	49	
				12.9	60	0.16	400	3300	50	7.1	69	0.11	400	3450	46	
				11.3	58	0.14	400	3300	47	6.3	59	0.09	400	3450	43	
				9.0	52	0.11	400	3300	42	5.0	59	0.08	400	3450	38	



95 Nm

		i	η <sub>s</sub> %	n <sub>1</sub> = 2800 min <sup>-1</sup>						n <sub>1</sub> = 1400 min <sup>-1</sup>						
				n <sub>2</sub> min <sup>-1</sup>	M <sub>n2</sub> Nm	P <sub>n1</sub> kW	R <sub>n1</sub> N	R <sub>n2</sub> N	η <sub>d</sub> %	n <sub>2</sub> min <sup>-1</sup>	M <sub>n2</sub> Nm	P <sub>n1</sub> kW	R <sub>n1</sub> N	R <sub>n2</sub> N	η <sub>d</sub> %	
				VFR 49												
				67	71	0.65	230	1920	76	33	78	0.37	230	2500	74	189
				52	68	0.50	230	2180	74	25.9	74	0.28	230	2830	71	
				39	68	0.40	230	2470	70	19.4	74	0.22	230	3190	67	
				33	82	0.44	230	2520	66	16.6	88	0.25	230	3290	62	
				25.9	75	0.33	230	2860	62	12.9	80	0.19	230	3450	58	
				20.7	71	0.27	230	3160	58	10.3	88	0.18	230	3450	54	
				15.6	64	0.20	230	3300	52	7.7	69	0.12	230	3450	48	
				13.3	60	0.17	230	3300	49	6.6	69	0.11	230	3450	45	
				11.7	58	0.15	230	3300	46	5.8	59	0.09	230	3450	42	
				9.3	52	0.12	230	3300	41	4.7	59	0.08	230	3450	37	
				n <sub>1</sub> = 900 min <sup>-1</sup>						n <sub>1</sub> = 500 min <sup>-1</sup>						
				21.4	82	0.26	230	2960	72	11.9	90	0.16	230	3450	70	189
				16.7	79	0.20	230	3330	69	9.3	83	0.12	230	3450	67	
				12.5	79	0.16	230	3450	64	6.9	83	0.10	230	3450	62	
				10.7	91	0.17	230	3450	59	6.0	95	0.10	230	3450	57	
				8.3	84	0.13	230	3450	55	4.6	90	0.08	230	3450	52	
				6.7	82	0.11	230	3450	50	3.7	90	0.07	230	3450	48	
				5.0	75	0.09	230	3450	45	2.8	78	0.05	230	3450	42	
				4.3	75	0.08	230	3450	41	2.4	78	0.05	230	3450	39	
				3.8	64	0.06	230	3450	39	2.1	68	0.04	230	3450	36	
				3.0	63	0.06	230	3450	34	1.7	65	0.04	230	3450	32	



## VF/VF 30/49

100 Nm

		i	η <sub>s</sub> %	n <sub>1</sub> = 1400 min <sup>-1</sup>						n <sub>1</sub> = 900 min <sup>-1</sup>						
				n <sub>2</sub> min <sup>-1</sup>	M <sub>n2</sub> Nm	P <sub>n1</sub> kW	R <sub>n1</sub> N	R <sub>n2</sub> N	η <sub>d</sub> %	n <sub>2</sub> min <sup>-1</sup>	M <sub>n2</sub> Nm	P <sub>n1</sub> kW	R <sub>n1</sub> N	R <sub>n2</sub> N	η <sub>d</sub> %	
				VF/VF 30/49												
	<b>VF/VF 30/49_240</b>	240	32	5.8	95	0.13	80	3450	45	3.8	100	0.09	150	3450	44	190
	<b>VF/VF 30/49_315</b>	315	24	4.4	95	0.11	140	3450	40	2.9	100	0.07	150	3450	43	
	<b>VF/VF 30/49_420</b>	420	24	3.3	95	0.08	—	3450	41	2.1	100	0.06	—	3450	37	
	<b>VF/VF 30/49_540</b>	540	22	2.6	95	0.07	—	3450	37	1.7	100	0.05	—	3450	35	
	<b>VF/VF 30/49_720</b>	720	20	1.9	95	0.05	—	3450	39	1.3	100	0.04	—	3450	33	
	<b>VF/VF 30/49_900</b>	900	18	1.6	95	0.05	—	3450	31	1.0	100	0.04	—	3450	26	
	<b>VF/VF 30/49_1120</b>	1120	15	1.3	95	0.04	—	3450	31	0.80	100	0.03	—	3450	28	
	<b>VF/VF 30/49_1440</b>	1440	14	0.97	95	0.04	—	3450	24	0.63	100	0.03	—	3450	22	
	<b>VF/VF 30/49_2160</b>	2160	11	0.65	95	0.03	—	3450	21	0.42	100	0.02	—	3450	22	
	<b>VF/VF 30/49_2700</b>	2700	10	0.52	95	0.03	—	3450	17	0.33	100	0.02	—	3450	17	

(-) Interpellare il ns. servizio tecnico comunicando i dati relativi al carico radiale (senso di rotazione, orientamento, posizione)

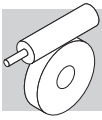

# W 63 - WR 63

**190 Nm**

	i	$\eta_s$ %	$n_1 = 2800 \text{ min}^{-1}$							$n_1 = 1400 \text{ min}^{-1}$								
			$n_2$ min <sup>-1</sup>	$M_{n2}$ Nm	$P_{n1}$ kW	$R_{n1}$ N	$R_{n2}$ N	$\eta_d$ %	$n_2$ min <sup>-1</sup>	$M_{n2}$ Nm	$P_{n1}$ kW	$R_{n1}$ N	$R_{n2}$ N	$\eta_d$ %				
<b>W 63</b>	W 63_7	7	70	400	105	4.9	480	1010	90	200	120	2.9	480	1550	88	188		
	W 63_10	10	66	280	125	4.2	370	1360	88	140	140	2.4	480	1840	86			
	W 63_12	12	63	233	125	3.5	435	1540	87	117	140	2.0	480	2070	85			
	W 63_15	15	59	187	125	2.8	410	1770	86	93	150	1.8	480	2280	83			
	W 63_19	19	55	147	130	2.4	310	1990	84	74	150	1.4	480	2600	81			
	W 63_24	24	52	117	130	1.9	370	2250	82	58	155	1.2	480	2890	78			
	W 63_30	30	44	93	125	1.6	440	2540	78	47	160	1.1	460	3170	74			
	W 63_38	38	40	74	130	1.3	330	2800	75	37	155	0.85	480	3580	70			
	W 63_45	45	37	62	130	1.2	380	3020	73	31	145	0.71	480	3920	67			
	W 63_64	64	31	44	110	0.75	480	3650	67	21.9	125	0.47	480	4680	61			
W 63_80	80	27	35	100	0.59	480	4050	62	17.5	115	0.38	480	5000	56				
W 63_100	100	23	28	100	0.51	480	4420	58	14.0	115	0.33	480	5000	51				
			$n_1 = 900 \text{ min}^{-1}$							$n_1 = 500 \text{ min}^{-1}$								
<b>W 63</b>	W 63_7	7	70	129	130	2.0	480	1870	87	71	140	1.2	480	2420	84	188		
	W 63_10	10	66	90	150	1.7	480	2220	84	50	165	1.1	480	2830	81			
	W 63_12	12	63	75	150	1.4	480	2480	82	42	165	0.92	480	3140	79			
	W 63_15	15	59	60	160	1.3	480	2740	80	33	180	0.83	480	3430	76			
	W 63_19	19	55	47	160	1.0	480	3100	78	26.3	180	0.68	480	3860	73			
	W 63_24	24	52	38	165	0.86	480	3440	75	20.8	185	0.58	480	4280	70			
	W 63_30	30	44	30	170	0.76	480	3770	70	16.7	190	0.52	480	4690	64			
	W 63_38	38	40	23.7	165	0.62	480	4240	66	13.2	185	0.42	480	5000	61			
	W 63_45	45	37	20.0	155	0.52	480	4630	63	11.1	170	0.34	480	5000	58			
	W 63_64	64	31	14.1	135	0.35	480	5000	56	7.8	150	0.24	480	5000	51			
W 63_80	80	27	11.3	125	0.28	480	5000	52	6.3	135	0.19	480	5000	46				
W 63_100	100	23	9.0	120	0.25	480	5000	46	5.0	130	0.17	480	5000	41				

**220 Nm**



	i	$\eta_s$ %	$n_1 = 2800 \text{ min}^{-1}$							$n_1 = 1400 \text{ min}^{-1}$								
			$n_2$ min <sup>-1</sup>	$M_{n2}$ Nm	$P_{n1}$ kW	$R_{n1}$ N	$R_{n2}$ N	$\eta_d$ %	$n_2$ min <sup>-1</sup>	$M_{n2}$ Nm	$P_{n1}$ kW	$R_{n1}$ N	$R_{n2}$ N	$\eta_d$ %				
<b>WR 63</b>	WR 63_21	21	69	133	130	2.1	180	1840	87	67	140	1.2	320	2510	84	189		
	WR 63_30	30	65	93	150	1.7	300	2180	84	47	165	1.0	320	2920	81			
	WR 63_36	36	62	78	150	1.5	320	2430	82	39	165	0.85	320	3240	79			
	WR 63_45	45	58	62	160	1.3	320	2690	80	31	180	0.77	320	3540	76			
	WR 63_57	57	54	49	160	1.1	320	3050	78	24.6	180	0.63	320	3980	73			
	WR 63_72	72	51	39	165	0.90	320	3390	75	19.4	185	0.54	320	4410	70			
	WR 63_90	90	44	31	170	0.79	320	3710	70	15.6	190	0.48	320	4830	64			
	WR 63_114	114	39	24.6	165	0.62	320	4170	68	12.3	185	0.39	320	5000	61			
	WR 63_135	135	36	20.7	155	0.53	320	4560	63	10.4	170	0.32	320	5000	58			
	WR 63_192	192	30	14.6	135	0.37	320	5000	56	7.3	150	0.22	320	5000	51			
WR 63_240	240	26	11.7	125	0.29	320	5000	52	5.8	135	0.18	320	5000	46				
WR 63_300	300	22	9.3	120	0.25	320	5000	46	4.7	130	0.15	320	5000	41				
			$n_1 = 900 \text{ min}^{-1}$							$n_1 = 500 \text{ min}^{-1}$								
<b>WR 63</b>	WR 63_21	21	69	43	155	0.85	320	2960	82	23.8	170	0.53	320	3750	80	189		
	WR 63_30	30	65	30	180	0.72	320	3470	79	16.7	200	0.45	320	4360	77			
	WR 63_36	36	62	25.0	180	0.61	320	3830	77	14.0	200	0.40	320	4790	74			
	WR 63_45	45	58	20.0	190	0.54	320	4230	74	11.1	200	0.33	320	5000	71			
	WR 63_57	57	54	15.8	190	0.44	320	4740	71	8.8	200	0.27	320	5000	68			
	WR 63_72	72	51	12.5	190	0.37	320	5000	68	6.9	190	0.22	320	5000	64			
	WR 63_90	90	44	10.0	205	0.35	320	5000	62	5.6	220	0.22	320	5000	58			
	WR 63_114	114	39	7.9	200	0.29	320	5000	58	4.4	210	0.18	320	5000	54			
	WR 63_135	135	36	6.7	180	0.23	320	5000	54	3.7	190	0.15	320	5000	50			
	WR 63_192	192	30	4.7	150	0.16	320	5000	47	2.6	150	0.10	320	5000	43			
WR 63_240	240	26	3.8	140	0.13	320	5000	43	2.1	140	0.08	320	5000	39				
WR 63_300	300	22	3.0	130	0.11	320	5000	38	1.7	130	0.07	320	5000	34				





## VF/W 30/63

230 Nm



		i	η <sub>s</sub> %	n <sub>1</sub> = 1400 min <sup>-1</sup>						n <sub>1</sub> = 900 min <sup>-1</sup>						
				n <sub>2</sub> min <sup>-1</sup>	M <sub>n2</sub> Nm	P <sub>n1</sub> kW	R <sub>n1</sub> N	R <sub>n2</sub> N	η <sub>d</sub> %	n <sub>2</sub> min <sup>-1</sup>	M <sub>n2</sub> Nm	P <sub>n1</sub> kW	R <sub>n1</sub> N	R <sub>n2</sub> N	η <sub>d</sub> %	
				VF/W 30/63												
	VF/W 30/63_240	240	33	5.8	210	0.27	80	5000	47	3.8	230	0.20	150	5000	45	190
	VF/W 30/63_315	315	26	4.4	210	0.23	140	5000	42	2.9	230	0.17	150	5000	41	
	VF/W 30/63_450	450	25	3.1	210	0.17	—	5000	41	2.0	230	0.11	—	5000	42	
	VF/W 30/63_570	570	22	2.5	210	0.14	—	5000	40	1.6	230	0.11	—	5000	36	
	VF/W 30/63_720	720	21	1.9	210	0.12	—	5000	37	1.3	230	0.09	—	5000	32	
	VF/W 30/63_900	900	18	1.6	210	0.11	—	5000	30	1.0	230	0.08	—	5000	29	
	VF/W 30/63_1200	1200	16	1.2	210	0.11	—	5000	24	0.75	230	0.07	—	5000	25	
	VF/W 30/63_1520	1520	14	0.92	210	0.08	—	5000	24	0.59	230	0.06	—	5000	23	
	VF/W 30/63_2280	2280	12	0.61	210	0.06	—	5000	21	0.39	230	0.04	—	5000	23	
	VF/W 30/63_2700	2700	11	0.52	210	0.05	—	5000	22	0.33	230	0.04	—	5000	19	

(-) Interpellare il ns. servizio tecnico comunicando i dati relativi al carico radiale (senso di rotazione, orientamento, posizione)





## W 75 - WR 75

**320 Nm**

		i	$\eta_s$ %	$n_1 = 2800 \text{ min}^{-1}$						$n_1 = 1400 \text{ min}^{-1}$							
				$n_2$ min <sup>-1</sup>	$M_{n2}$ Nm	$P_{n1}$ kW	$R_{n1}$ N	$R_{n2}$ N	$\eta_d$ %	$n_2$ min <sup>-1</sup>	$M_{n2}$ Nm	$P_{n1}$ kW	$R_{n1}$ N	$R_{n2}$ N	$\eta_d$ %		
<b>W 75</b>	W 75_7	7	71	400	170	7.8	750	700	91	200	190	4.4	750	1530	90	188	
	W 75_10	10	67	280	205	6.7	750	1610	90	140	230	3.8	750	2240	88		
	W 75_15	15	60	187	225	5.0	750	2120	88	93	250	2.9	750	2870	85		
	W 75_20	20	56	140	225	3.8	750	2550	86	70	250	2.2	750	3410	83		
	W 75_25	25	52	112	225	3.2	750	2900	83	56	250	1.8	750	3840	80		
	W 75_30	30	45	93	240	2.9	750	3100	81	47	270	1.7	750	4090	77		
	W 75_40	40	40	70	225	2.1	750	3660	77	35	255	1.3	750	4770	72		
	W 75_50	50	36	56	195	1.6	750	4180	73	28.0	220	0.95	750	5410	68		
	W 75_60	60	33	47	180	1.3	750	4610	70	23.3	200	0.75	750	5960	65		
	W 75_80	80	28	35	160	0.90	750	5310	65	17.5	180	0.56	750	6200	59		
W 75_100	100	25	28.0	135	0.65	750	5960	61	14.0	150	0.40	750	6200	55			
				$n_1 = 900 \text{ min}^{-1}$						$n_1 = 500 \text{ min}^{-1}$							
<b>W 75</b>	W 75_7	7	71	129	205	3.1	750	2120	88	71	225	2.0	750	2940	86	188	
	W 75_10	10	67	90	250	2.7	750	2700	86	50	275	1.7	750	3480	84		
	W 75_15	15	60	60	270	2.0	750	3440	83	33	295	1.3	750	4380	80		
	W 75_20	20	56	45	270	1.6	750	4050	80	25.0	295	1.0	750	5120	77		
	W 75_25	25	52	36	270	1.3	750	4550	77	20.0	295	0.85	750	5720	73		
	W 75_30	30	45	30	290	1.2	750	4860	74	16.7	320	0.81	750	6080	69		
	W 75_40	40	40	22.5	275	1.0	750	5630	68	12.5	305	0.63	750	6200	63		
	W 75_50	50	36	18.0	235	0.70	750	6200	63	10.0	260	0.47	750	6200	58		
	W 75_60	60	33	15.0	215	0.56	750	6200	60	8.3	235	0.37	750	6200	55		
	W 75_80	80	28	11.3	195	0.43	750	6200	54	6.3	215	0.29	750	6200	49		
W 75_100	100	25	9.0	160	0.30	750	6200	50	5.0	180	0.21	750	6200	44			

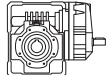
**420 Nm**

		i	$\eta_s$ %	$n_1 = 2800 \text{ min}^{-1}$						$n_1 = 1400 \text{ min}^{-1}$							
				$n_2$ min <sup>-1</sup>	$M_{n2}$ Nm	$P_{n1}$ kW	$R_{n1}$ N	$R_{n2}$ N	$\eta_d$ %	$n_2$ min <sup>-1</sup>	$M_{n2}$ Nm	$P_{n1}$ kW	$R_{n1}$ N	$R_{n2}$ N	$\eta_d$ %		
<b>WR 75</b>	WR 75_21	21	70	133	205	3.3	500	2030	88	67	225	1.8	500	3060	86	189	
	WR 75_30	30	66	93	250	2.8	500	2640	86	47	275	1.6	500	3610	84		
	WR 75_45	45	59	62	270	2.1	500	3380	83	31	295	1.2	500	4530	80		
	WR 75_60	60	55	47	270	1.6	500	3980	80	23.3	295	0.94	500	5280	77		
	WR 75_75	75	51	37	270	1.4	500	4480	77	18.7	295	0.79	500	5890	73		
	WR 75_90	90	44	31	290	1.3	500	4780	74	15.6	320	0.76	500	6200	69		
	WR 75_120	120	39	23.3	275	1.0	500	5540	68	11.7	305	0.59	500	6200	63		
	WR 75_150	150	35	18.7	235	0.73	500	6200	63	9.3	260	0.44	500	6200	58		
	WR 75_180	180	32	15.6	215	0.58	500	6200	60	7.8	235	0.35	500	6200	55		
	WR 75_240	240	27	11.7	195	0.44	500	6200	54	5.8	215	0.27	500	6200	49		
WR 75_300	300	24	9.3	160	0.31	500	6200	50	4.7	180	0.20	500	6200	44			
				$n_1 = 900 \text{ min}^{-1}$						$n_1 = 500 \text{ min}^{-1}$							
<b>WR 75</b>	WR 75_21	21	70	43	245	1.3	500	3660	85	23.8	270	0.82	500	4660	82	189	
	WR 75_30	30	66	30	330	1.3	500	4070	82	16.7	370	0.81	500	5160	80		
	WR 75_45	45	59	20.0	350	0.94	500	5180	78	11.1	400	0.62	500	6200	75		
	WR 75_60	60	55	15.0	330	0.69	500	6180	75	8.3	370	0.45	500	6200	71		
	WR 75_75	75	51	12.0	330	0.59	500	6200	70	6.7	350	0.37	500	6200	66		
	WR 75_90	90	44	10.0	370	0.58	500	6200	67	5.6	420	0.39	500	6200	63		
	WR 75_120	120	39	7.5	330	0.43	500	6200	60	4.2	380	0.30	500	6200	56		
	WR 75_150	150	35	6.0	310	0.35	500	6200	55	3.3	350	0.24	500	6200	51		
	WR 75_180	180	32	5.0	280	0.29	500	6200	51	2.8	320	0.20	500	6200	47		
	WR 75_240	240	27	3.8	220	0.19	500	6200	45	2.1	280	0.15	500	6200	41		
WR 75_300	300	24	3.0	200	0.15	500	6200	41	1.7	260	0.12	500	6200	37			

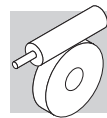

## WR 75 - VF/W 44/75

370 Nm



i	$\eta_s$ %	$n_1 = 2800 \text{ min}^{-1}$							$n_1 = 1400 \text{ min}^{-1}$						
		$n_2$ min <sup>-1</sup>	$M_{n2}$ Nm	$P_{n1}$ kW	$R_{n1}$ N	$R_{n2}$ N	$\eta_d$ %	$n_2$ min <sup>-1</sup>	$M_{n2}$ Nm	$P_{n1}$ kW	$R_{n1}$ N	$R_{n2}$ N	$\eta_d$ %		



WR 75_P90_B5			$n_1 = 2800 \text{ min}^{-1}$							$n_1 = 1400 \text{ min}^{-1}$							189
	i	$\eta_s$ %	$n_2$ min <sup>-1</sup>	$M_{n2}$ Nm	$P_{n1}$ kW	$R_{n1}$ N	$R_{n2}$ N	$\eta_d$ %	$n_2$ min <sup>-1</sup>	$M_{n2}$ Nm	$P_{n1}$ kW	$R_{n1}$ N	$R_{n2}$ N	$\eta_d$ %			
WR 75_15	15	66	187	220	4.9	—	1960	89	93	250	2.9	—	2640	86			
WR 75_22.5	22.5	59	124	240	3.7	—	2530	86	62	270	2.1	—	3380	83			
WR 75_30	30	55	93	240	2.8	—	3020	84	47	270	1.7	—	3980	80			
WR 75_37.5	37.5	51	75	240	2.3	—	3410	81	37	270	1.4	—	4480	77			
WR 75_45	45	44	62	255	2.1	—	3660	79	31	290	1.3	—	4780	74			
WR 75_60	60	39	47	240	1.6	—	4290	74	23.3	275	1.0	—	5540	68			
WR 75_75	75	35	37	210	1.2	—	4860	70	18.7	235	0.74	—	6200	63			
WR 75_90	90	32	31	190	0.93	—	4460	67	15.6	215	0.59	—	6200	60			
WR 75_120	120	27	23.3	170	0.69	—	4960	61	11.7	195	0.44	—	6200	54			
WR 75_150	150	24	18.7	145	0.49	—	5150	58	9.3	160	0.32	—	6200	50			
		$n_1 = 900 \text{ min}^{-1}$							$n_1 = 500 \text{ min}^{-1}$							189	
i	$\eta_s$ %	$n_2$ min <sup>-1</sup>	$M_{n2}$ Nm	$P_{n1}$ kW	$R_{n1}$ N	$R_{n2}$ N	$\eta_d$ %	$n_2$ min <sup>-1</sup>	$M_{n2}$ Nm	$P_{n1}$ kW	$R_{n1}$ N	$R_{n2}$ N	$\eta_d$ %				
WR 75_15	15	66	60	275	2.1	—	3150	84	33	330	1.4	—	3850	82			
WR 75_22.5	22.5	59	40	295	1.6	—	4010	80	22.2	350	1.0	—	4920	78			
WR 75_30	30	55	30	295	1.2	—	4710	77	16.7	330	0.77	—	5890	75			
WR 75_37.5	37.5	51	24	295	1.0	—	5280	73	13.3	330	0.66	—	6200	70			
WR 75_45	45	44	20	320	0.98	—	5610	69	11.1	370	0.64	—	6200	67			
WR 75_60	60	39	15	305	0.77	—	6200	63	8.3	330	0.48	—	6200	60			
WR 75_75	75	35	12	260	0.57	—	6200	58	6.7	310	0.39	—	6200	55			
WR 75_90	90	32	10	235	0.45	—	6200	55	5.6	280	0.32	—	6200	52			
WR 75_120	120	27	7.5	215	0.35	—	6200	49	4.2	220	0.21	—	6200	46			
WR 75_150	150	24	6.0	180	0.26	—	6200	44	3.3	200	0.17	—	6200	41			

400 Nm



i	$\eta_s$ %	$n_1 = 1400 \text{ min}^{-1}$							$n_1 = 900 \text{ min}^{-1}$						
		$n_2$ min <sup>-1</sup>	$M_{n2}$ Nm	$P_{n1}$ kW	$R_{n1}$ N	$R_{n2}$ N	$\eta_d$ %	$n_2$ min <sup>-1</sup>	$M_{n2}$ Nm	$P_{n1}$ kW	$R_{n1}$ N	$R_{n2}$ N	$\eta_d$ %		



VF/W 44/75			$n_1 = 1400 \text{ min}^{-1}$							$n_1 = 900 \text{ min}^{-1}$							190
	i	$\eta_s$ %	$n_2$ min <sup>-1</sup>	$M_{n2}$ Nm	$P_{n1}$ kW	$R_{n1}$ N	$R_{n2}$ N	$\eta_d$ %	$n_2$ min <sup>-1</sup>	$M_{n2}$ Nm	$P_{n1}$ kW	$R_{n1}$ N	$R_{n2}$ N	$\eta_d$ %			
VF/W 44/75_250	250	34	5.6	370	0.38	220	4560	57	3.6	400	0.29	220	4660	52			
VF/W 44/75_300	300	30	4.7	370	0.35	220	5160	51	3.0	400	0.27	220	5150	46			
VF/W 44/75_400	400	26	3.5	370	0.29	220	6200	46	2.3	400	0.22	220	6200	42			
VF/W 44/75_525	525	25	2.7	370	0.23	220	6200	44	1.7	400	0.18	220	6200	41			
VF/W 44/75_700	700	24	2.0	370	0.18	220	6200	42	1.3	400	0.14	220	6200	39			
VF/W 44/75_920	920	21	1.5	370	0.15	—	6200	40	1.0	400	0.11	60	6200	36			
VF/W 44/75_1200	1200	18	1.2	370	0.12	—	6200	37	0.75	400	0.10	220	6200	31			
VF/W 44/75_1500	1500	17	0.93	370	0.10	220	6200	37	0.60	400	0.09	220	6200	29			
VF/W 44/75_2100	2100	14	0.67	370	0.09	220	6200	30	0.43	400	0.07	220	6200	24			
VF/W 44/75_2800	2800	12	0.50	370	0.07	220	6200	26	0.32	400	0.06	220	6200	22			

(-) Interpellare il ns. servizio tecnico comunicando i dati relativi al carico radiale (senso di rotazione, orientamento, posizione)

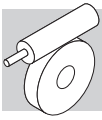

## W 86 - WR 86

**440 Nm**

		i	η <sub>s</sub> %	n <sub>1</sub> = 2800 min <sup>-1</sup>						n <sub>1</sub> = 1400 min <sup>-1</sup>							
				n <sub>2</sub> min <sup>-1</sup>	M <sub>n2</sub> Nm	P <sub>n1</sub> kW	R <sub>n1</sub> N	R <sub>n2</sub> N	η <sub>d</sub> %	n <sub>2</sub> min <sup>-1</sup>	M <sub>n2</sub> Nm	P <sub>n1</sub> kW	R <sub>n1</sub> N	R <sub>n2</sub> N	η <sub>d</sub> %		
				W 86													
<b>W 86</b>	W 86_7	7	71	400	225	10.4	850	2930	91	200	250	5.9	850	3920	89	188	
	W 86_10	10	67	280	260	8.5	850	3490	90	140	290	4.8	850	4620	88		
	W 86_15	15	60	187	295	6.6	850	4200	87	93	330	3.8	850	5510	85		
	W 86_20	20	60	140	285	4.9	850	4900	86	70	320	2.8	850	6380	84		
	W 86_23	23	58	122	285	4.3	850	5250	85	61	320	2.5	850	6800	82		
	W 86_30	30	45	93	320	3.9	850	5740	81	47	370	2.4	850	7000	76		
	W 86_40	40	45	70	295	2.7	850	6670	79	35	330	1.6	850	7000	75		
	W 86_46	46	43	61	305	2.5	850	7000	77	30	340	1.5	850	7000	73		
	W 86_56	56	39	50	265	1.8	850	7000	75	25.0	300	1.1	850	7000	70		
	W 86_64	64	37	44	250	1.6	850	7000	73	21.9	280	0.94	850	7000	68		
W 86_80	80	33	35	225	1.2	850	7000	69	17.5	255	0.73	850	7000	64			
W 86_100	100	29	28.0	205	0.92	850	7000	65	14.0	230	0.57	850	7000	59			
				n <sub>1</sub> = 900 min <sup>-1</sup>						n <sub>1</sub> = 500 min <sup>-1</sup>							
<b>W 86</b>	W 86_7	7	71	129	270	4.1	850	4670	88	71	295	2.6	850	5890	85	188	
	W 86_10	10	67	90	310	3.4	850	5500	86	50	345	2.2	850	6860	82		
	W 86_15	15	60	60	355	2.7	850	6520	82	33	390	1.7	850	7000	78		
	W 86_20	20	60	45	345	2.0	850	7000	81	25.0	380	1.3	850	7000	77		
	W 86_23	23	58	39	345	1.8	850	7000	80	21.7	380	1.2	850	7000	75		
	W 86_30	30	45	30	400	1.7	850	7000	73	16.7	440	1.1	850	7000	67		
	W 86_40	40	45	22.5	355	1.2	850	7000	71	12.5	390	0.77	850	7000	66		
	W 86_46	46	43	19.6	365	1.1	850	7000	69	10.9	405	0.73	850	7000	63		
	W 86_56	56	39	16.1	325	0.83	850	7000	66	8.9	355	0.55	850	7000	60		
	W 86_64	64	37	14.1	300	0.70	850	7000	63	7.8	330	0.47	850	7000	58		
W 86_80	80	33	11.3	275	0.55	850	7000	59	6.3	305	0.38	850	7000	53			
W 86_100	100	29	9.0	250	0.43	850	7000	55	5.0	275	0.29	850	7000	49			

**550 Nm**

		i	η <sub>s</sub> %	n <sub>1</sub> = 2800 min <sup>-1</sup>						n <sub>1</sub> = 1400 min <sup>-1</sup>							
				n <sub>2</sub> min <sup>-1</sup>	M <sub>n2</sub> Nm	P <sub>n1</sub> kW	R <sub>n1</sub> N	R <sub>n2</sub> N	η <sub>d</sub> %	n <sub>2</sub> min <sup>-1</sup>	M <sub>n2</sub> Nm	P <sub>n1</sub> kW	R <sub>n1</sub> N	R <sub>n2</sub> N	η <sub>d</sub> %		
				WR 86													
<b>WR 86</b>	WR 86_21	21	70	133	270	4.3	500	4590	88	67	295	2.4	500	6070	85	189	
	WR 86_30	30	66	93	310	3.5	500	5410	86	47	345	2.1	500	7000	82		
	WR 86_45	45	59	62	355	2.8	500	6420	82	31	390	1.6	500	7000	78		
	WR 86_60	60	59	47	345	2.1	500	7000	81	23.3	380	1.2	500	7000	77		
	WR 86_69	69	57	41	345	1.8	500	7000	80	20.3	380	1.1	500	7000	75		
	WR 86_90	90	44	31	400	1.8	500	7000	73	15.6	440	1.1	500	7000	67		
	WR 86_120	120	44	23.3	355	1.2	500	7000	71	11.7	390	0.72	500	7000	66		
	WR 86_138	138	42	20.3	365	1.1	500	7000	69	10.1	405	0.68	500	7000	63		
	WR 86_168	168	38	16.7	325	0.86	500	7000	66	8.3	355	0.52	500	7000	60		
	WR 86_192	192	36	14.6	300	0.73	500	7000	63	7.3	330	0.43	500	7000	58		
WR 86_240	240	32	11.7	275	0.57	500	7000	59	5.8	305	0.35	500	7000	53			
WR 86_300	300	28	9.3	250	0.44	500	7000	55	4.7	275	0.27	500	7000	49			
				n <sub>1</sub> = 900 min <sup>-1</sup>						n <sub>1</sub> = 500 min <sup>-1</sup>							
<b>WR 86</b>	WR 86_21	21	70	43	325	1.8	500	7000	83	23.8	355	1.1	500	7000	81	189	
	WR 86_30	30	66	30	375	1.5	500	7000	81	16.7	415	0.93	500	7000	78		
	WR 86_45	45	59	20.0	450	1.2	500	7000	76	11.1	500	0.80	500	7000	73		
	WR 86_60	60	59	15.0	430	0.90	500	7000	75	8.3	440	0.53	500	7000	72		
	WR 86_69	69	57	13.0	390	0.73	500	7000	73	7.2	400	0.43	500	7000	70		
	WR 86_90	90	44	10.0	500	0.82	500	7000	64	5.6	550	0.53	500	7000	60		
	WR 86_120	120	44	7.5	440	0.55	500	7000	63	4.2	470	0.35	500	7000	59		
	WR 86_138	138	42	6.5	430	0.48	500	7000	61	3.6	440	0.30	500	7000	56		
	WR 86_168	168	38	5.4	390	0.38	500	7000	57	3.0	410	0.24	500	7000	53		
	WR 86_192	192	36	4.7	390	0.35	500	7000	55	2.6	410	0.22	500	7000	50		
WR 86_240	240	32	3.8	310	0.24	500	7000	50	2.1	320	0.15	500	7000	46			
WR 86_300	300	28	3.0	310	0.22	500	7000	45	1.7	320	0.14	500	7000	41			



## WR 86 - VF/W 44/86

**500 Nm**



i	η <sub>s</sub> %	n <sub>1</sub> = 2800 min <sup>-1</sup>							n <sub>1</sub> = 1400 min <sup>-1</sup>						
		n <sub>2</sub> min <sup>-1</sup>	M <sub>n2</sub> Nm	P <sub>n1</sub> kW	R <sub>n1</sub> N	R <sub>n2</sub> N	η <sub>d</sub> %	n <sub>2</sub> min <sup>-1</sup>	M <sub>n2</sub> Nm	P <sub>n1</sub> kW	R <sub>n1</sub> N	R <sub>n2</sub> N	η <sub>d</sub> %		



<b>WR 86_P90 B5</b>	WR 86_15	15	66	187	275	6.1	—	4130	88	93	310	3.5	—	5410	86	189			
	WR 86_22.5	22.5	59	124	315	4.8	—	4920	86	62	355	2.8	—	6420	82				
	WR 86_30	30	59	93	305	3.5	—	5720	85	47	345	2.1	—	7000	81				
	WR 86_34.5	34.5	57	81	305	3.1	—	6110	84	41	345	1.8	—	7000	80				
	WR 86_45	45	44	62	350	3.0	—	6640	77	31	400	1.8	—	7000	73				
	WR 86_60	60	44	47	315	2.0	—	7000	77	23.3	355	1.2	—	7000	71				
	WR 86_69	69	42	41	325	1.8	—	7000	75	20.3	365	1.1	—	7000	69				
	WR 86_84	84	38	33	285	1.4	—	7000	72	16.7	325	0.86	—	7000	66				
	WR 86_96	96	36	29.2	265	1.2	—	7000	70	14.6	300	0.73	—	7000	63				
	WR 86_120	120	32	23.3	240	0.88	—	7000	67	11.7	275	0.57	—	7000	59				
WR 86_150	150	28	18.7	220	0.69	—	7000	62	9.3	250	0.44	—	7000	55					
				n <sub>1</sub> = 900 min <sup>-1</sup>							n <sub>1</sub> = 500 min <sup>-1</sup>								
<b>WR 86_P90 B5</b>	WR 86_15	15	66	60	345	2.6	—	6330	82	33	375	1.6	—	7000	81	189			
	WR 86_22.5	22.5	59	40	390	2.1	—	7000	78	22.2	450	1.4	—	7000	76				
	WR 86_30	30	59	30	380	1.6	—	7000	77	16.7	430	1.0	—	7000	75				
	WR 86_34.5	34.5	57	26.1	380	1.4	—	7000	75	14.5	390	0.81	—	7000	73				
	WR 86_45	45	44	20.0	440	1.4	—	7000	67	11.1	500	0.91	—	7000	64				
	WR 86_60	60	44	15.0	390	0.93	—	7000	66	8.3	440	0.61	—	7000	63				
	WR 86_69	69	42	13.0	405	0.88	—	7000	63	7.2	430	0.53	—	7000	61				
	WR 86_84	84	38	10.7	355	0.66	—	7000	60	6.0	390	0.43	—	7000	57				
	WR 86_96	96	36	9.4	330	0.56	—	7000	58	5.2	390	0.39	—	7000	55				
	WR 86_120	120	32	7.5	305	0.45	—	7000	53	4.2	310	0.27	—	7000	50				
WR 86_150	150	28	6.0	275	0.35	—	7000	49	3.3	310	0.24	—	7000	46					

**550 Nm**



i	η <sub>s</sub> %	n <sub>1</sub> = 1400 min <sup>-1</sup>							n <sub>1</sub> = 900 min <sup>-1</sup>						
		n <sub>2</sub> min <sup>-1</sup>	M <sub>n2</sub> Nm	P <sub>n1</sub> kW	R <sub>n1</sub> N	R <sub>n2</sub> N	η <sub>d</sub> %	n <sub>2</sub> min <sup>-1</sup>	M <sub>n2</sub> Nm	P <sub>n1</sub> kW	R <sub>n1</sub> N	R <sub>n2</sub> N	η <sub>d</sub> %		



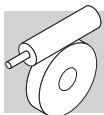

<b>VF/W 44/86</b>	VF/W 44/86_230	230	38	6.1	500	0.59	220	7000	54	3.9	550	0.43	220	7000	53	190
	VF/W 44/86_300	300	30	4.7	500	0.54	220	7000	45	3.0	550	0.41	220	7000	42	
	VF/W 44/86_400	400	30	3.5	500	0.45	220	7000	41	2.3	550	0.32	220	7000	41	
	VF/W 44/86_525	525	25	2.7	500	0.33	220	7000	42	1.7	550	0.25	220	7000	39	
	VF/W 44/86_700	700	25	2.0	500	0.27	220	7000	39	1.3	550	0.20	220	7000	37	
	VF/W 44/86_920	920	22	1.5	500	0.20	220	7000	40	1.0	550	0.15	—	7000	37	
	VF/W 44/86_1380	1380	17	1.0	500	0.17	220	7000	32	0.65	550	0.13	—	7000	28	
	VF/W 44/86_1840	1840	17	0.76	500	0.13	220	7000	30	0.49	550	0.10	—	7000	28	
	VF/W 44/86_2116	2116	16	0.66	500	0.12	220	7000	28	0.43	550	0.09	220	7000	28	
VF/W 44/86_2760	2760	14	0.51	500	0.11	—	7000	24	0.33	550	0.08	220	7000	24		

(-) Interpellare il ns. servizio tecnico comunicando i dati relativi al carico radiale (senso di rotazione, orientamento, posizione)





# W 110 - WR 110

830 Nm

		i	$\eta_s$ %	$n_1 = 2800 \text{ min}^{-1}$					$n_1 = 1400 \text{ min}^{-1}$							
				$n_2$ min <sup>-1</sup>	$M_{n2}$ Nm	$P_{n1}$ kW	$R_{n1}$ N	$R_{n2}$ N	$\eta_d$ %	$n_2$ min <sup>-1</sup>	$M_{n2}$ Nm	$P_{n1}$ kW	$R_{n1}$ N		$R_{n2}$ N	$\eta_d$ %
<b>W 110</b>	<b>W 110_7</b>	7	71	400	445	20.7	1200	3710	90	200	500	11.8	1200	5020	89	188
	<b>W 110_10</b>	10	67	280	490	16.1	1200	4650	89	140	550	9.3	1200	6190	87	
	<b>W 110_15</b>	15	60	187	535	12.0	1200	5770	87	93	600	7.0	1200	7590	84	
	<b>W 110_20</b>	20	61	140	510	8.7	1200	6790	86	70	570	5.0	1200	8000	84	
	<b>W 110_23</b>	23	59	122	480	7.1	1200	7430	86	61	540	4.1	1200	8000	83	
	<b>W 110_30</b>	30	45	93	625	7.5	1200	7780	81	47	700	4.4	1200	8000	77	
	<b>W 110_40</b>	40	46	70	595	5.5	1200	8000	80	35	670	3.2	1200	8000	76	
	<b>W 110_46</b>	46	44	61	535	4.3	1200	8000	79	30	600	2.6	1200	8000	74	
	<b>W 110_56</b>	56	41	50	535	3.7	1200	8000	76	25.0	600	2.2	1200	8000	72	
	<b>W 110_64</b>	64	38	44	470	2.9	1200	8000	74	21.9	530	1.7	1200	8000	70	
<b>W 110_80</b>	80	34	35	420	2.2	1200	8000	71	17.5	470	1.3	1200	8000	66		
<b>W 110_100</b>	100	30	28.0	410	1.8	1200	8000	67	14.0	460	1.1	1200	8000	62		
				$n_1 = 900 \text{ min}^{-1}$					$n_1 = 500 \text{ min}^{-1}$							
<b>W 110</b>	<b>W 110_7</b>	7	71	129	540	8.3	1200	6040	88	71	595	5.2	1200	7680	86	188
	<b>W 110_10</b>	10	67	90	590	6.5	1200	7410	86	50	655	4.1	1200	8000	84	
	<b>W 110_15</b>	15	60	60	645	4.9	1200	8000	83	33	710	3.1	1200	8000	80	
	<b>W 110_20</b>	20	61	45	615	3.5	1200	8000	82	25.0	675	2.2	1200	8000	79	
	<b>W 110_23</b>	23	59	39	580	2.9	1200	8000	81	21.7	640	1.9	1200	8000	77	
	<b>W 110_30</b>	30	45	30	755	3.2	1200	8000	74	16.7	830	2.1	1200	8000	70	
	<b>W 110_40</b>	40	46	22.5	720	2.3	1200	8000	73	12.5	795	1.5	1200	8000	68	
	<b>W 110_46</b>	46	44	19.6	645	1.9	1200	8000	71	10.9	710	1.2	1200	8000	66	
	<b>W 110_56</b>	56	41	16.1	645	1.6	1200	8000	68	8.9	710	1.1	1200	8000	63	
	<b>W 110_64</b>	64	38	14.1	570	1.3	1200	8000	65	7.8	630	0.86	1200	8000	60	
<b>W 110_80</b>	80	34	11.3	505	0.98	1200	8000	61	6.3	560	0.65	1200	8000	56		
<b>W 110_100</b>	100	30	9.0	495	0.82	1200	8000	57	5.0	545	0.56	1200	8000	51		

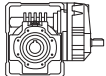
1000 Nm

		i	$\eta_s$ %	$n_1 = 2800 \text{ min}^{-1}$					$n_1 = 1400 \text{ min}^{-1}$							
				$n_2$ min <sup>-1</sup>	$M_{n2}$ Nm	$P_{n1}$ kW	$R_{n1}$ N	$R_{n2}$ N	$\eta_d$ %	$n_2$ min <sup>-1</sup>	$M_{n2}$ Nm	$P_{n1}$ kW	$R_{n1}$ N		$R_{n2}$ N	$\eta_d$ %
<b>WR 110</b>	<b>WR 110_21</b>	21	70	133	540	8.6	700	5930	88	67	595	4.8	700	7950	86	189
	<b>WR 110_30</b>	30	66	93	590	6.7	700	7280	86	47	655	3.8	700	8000	84	
	<b>WR 110_45</b>	45	59	62	645	5.1	700	8000	83	31	710	2.9	700	8000	80	
	<b>WR 110_60</b>	60	60	47	615	3.7	700	8000	82	23.3	675	2.1	700	8000	79	
	<b>WR 110_69</b>	69	58	41	580	3.0	700	8000	81	20.3	640	1.8	700	8000	77	
	<b>WR 110_90</b>	90	44	31	755	3.3	700	8000	74	15.6	830	1.9	700	8000	70	
	<b>WR 110_120</b>	120	45	23.3	720	2.4	700	8000	73	11.7	795	1.4	700	8000	68	
	<b>WR 110_138</b>	138	43	20.3	645	1.9	700	8000	71	10.1	710	1.1	700	8000	66	
	<b>WR 110_168</b>	168	40	16.7	645	1.7	700	8000	68	8.3	710	0.98	700	8000	63	
	<b>WR 110_192</b>	192	37	14.6	570	1.3	700	8000	65	7.3	630	0.80	700	8000	60	
<b>WR 110_240</b>	240	33	11.7	505	1.0	700	8000	61	5.8	560	0.61	700	8000	56		
<b>WR 110_300</b>	300	29	9.3	495	0.85	700	8000	57	4.7	545	0.52	700	8000	51		
				$n_1 = 900 \text{ min}^{-1}$					$n_1 = 500 \text{ min}^{-1}$							
<b>WR 110</b>	<b>WR 110_21</b>	21	70	43	645	3.4	700	8000	84	23.8	715	2.2	700	8000	82	189
	<b>WR 110_30</b>	30	66	30	710	2.8	700	8000	81	16.7	785	1.7	700	8000	79	
	<b>WR 110_45</b>	45	59	20.0	870	2.4	700	8000	77	11.1	950	1.5	700	8000	75	
	<b>WR 110_60</b>	60	60	15.0	800	1.6	700	8000	77	8.3	850	1.0	700	8000	74	
	<b>WR 110_69</b>	69	58	13.0	750	1.4	700	8000	75	7.2	820	0.86	700	8000	72	
	<b>WR 110_90</b>	90	44	10.0	900	1.4	700	8000	66	5.6	1000	0.94	700	8000	62	
	<b>WR 110_120</b>	120	45	7.5	870	1.1	700	8000	65	4.2	950	0.68	700	8000	61	
	<b>WR 110_138</b>	138	43	6.5	800	0.87	700	8000	63	3.6	900	0.58	700	8000	59	
	<b>WR 110_168</b>	168	40	5.4	775	0.72	700	8000	60	3.0	800	0.45	700	8000	55	
	<b>WR 110_192</b>	192	37	4.7	685	0.59	700	8000	57	2.6	720	0.37	700	8000	53	
<b>WR 110_240</b>	240	33	3.8	590	0.44	700	8000	53	2.1	620	0.28	700	8000	48		
<b>WR 110_300</b>	300	29	3.0	570	0.37	700	8000	48	1.7	600	0.24	700	8000	44		



# VF/W 49/110

1050 Nm



	i	$\eta_s$ %	$n_1 = 1400 \text{ min}^{-1}$							$n_1 = 900 \text{ min}^{-1}$					
			$n_2$ min <sup>-1</sup>	$M_{n2}$ Nm	$P_{n1}$ kW	$R_{n1}$ N	$R_{n2}$ N	$\eta_d$ %	$n_2$ min <sup>-1</sup>	$M_{n2}$ Nm	$P_{n1}$ kW	$R_{n1}$ N	$R_{n2}$ N	$\eta_d$ %	
			VF/W 49/110												
VF/W 49/110_230	230	38	6.1	1000	1.2	400	8000	52	3.9	1050	0.84	400	8000	51	190
VF/W 49/110_300	300	29	4.7	1000	1.0	400	8000	48	3.0	1050	0.70	400	8000	47	
VF/W 49/110_400	400	30	3.5	1000	0.81	400	8000	45	2.3	1050	0.55	400	8000	45	
VF/W 49/110_540	540	25	2.6	1000	0.66	400	8000	41	1.7	1050	0.48	400	8000	38	
VF/W 49/110_720	720	24	1.9	1000	0.51	400	8000	40	1.3	1050	0.36	400	8000	38	
VF/W 49/110_1080	1080	18	1.3	1000	0.44	400	8000	31	0.83	1050	0.28	400	8000	30	
VF/W 49/110_1350	1350	16	1.0	1000	0.36	400	8000	30	0.67	1050	0.26	400	8000	28	
VF/W 49/110_1656	1656	17	0.85	1000	0.30	400	8000	30	0.54	1050	0.20	400	8000	30	
VF/W 49/110_2070	2070	15	0.68	1000	0.25	400	8000	28	0.43	1050	0.19	400	8000	25	
VF/W 49/110_2800	2800	13	0.50	1000	0.22	400	8000	24	0.32	1050	0.17	400	8000	21	



## VF 130 - VFR 130

1500 Nm

			$i$	$\eta_s$ %	$n_1 = 2800 \text{ min}^{-1}$					$n_1 = 1400 \text{ min}^{-1}$							
					$n_2$ min <sup>-1</sup>	$M_{n2}$ Nm	$P_{n1}$ kW	$R_{n1}$ N	$R_{n2}$ N	$\eta_d$ %	$n_2$ min <sup>-1</sup>	$M_{n2}$ Nm	$P_{n1}$ kW	$R_{n1}$ N		$R_{n2}$ N	$\eta_d$ %
<b>VF 130</b>	VF 130_7	7	71	400	555	25	1500	4930	91	200	740	17.4	1500	5990	89	188	
	VF 130_10	10	67	280	593	19.3	1500	6210	90	140	790	13.3	1500	7620	88		
	VF 130_15	15	63	187	690	15.3	1500	7390	88	93	920	10.6	1500	9100	86		
	VF 130_20	20	59	140	675	11.4	1500	8670	87	70	900	8.0	1500	10700	84		
	VF 130_23	23	57	122	668	9.9	1500	9300	86	61	890	6.9	1500	11500	83		
	VF 130_30	30	49	93	788	9.3	1040	10100	83	47	1050	6.6	—	12500	79		
	VF 130_40	40	44	70	825	7.6	—	11400	80	35	1100	5.4	—	12600	76		
	VF 130_46	46	45	61	788	6.3	1290	12200	80	30.0	1050	4.5	—	12600	76		
	VF 130_56	56	42	50	720	4.8	1500	12600	78	25.0	960	3.4	940	12600	73		
	VF 130_64	64	39	44	698	4.2	1500	12600	76	21.9	930	3.0	1220	12600	71		
	VF 130_80	80	35	35	660	3.3	1500	12600	73	17.5	880	2.4	1500	12600	68		
VF 130_100	100	31	28	585	2.5	1500	12600	70	14.0	780	1.8	1500	12600	64			
					$n_1 = 900 \text{ min}^{-1}$					$n_1 = 500 \text{ min}^{-1}$							
<b>VF 130</b>	VF 130_7	7	71	129	850	13.0	1500	6980	88	71	1000	8.8	1500	8670	86	188	
	VF 130_10	10	67	90	900	9.9	1500	8900	87	50	1100	6.9	1500	10800	84		
	VF 130_15	15	63	60	1080	8.1	1500	10490	84	33	1350	5.9	1500	12600	81		
	VF 130_20	20	59	45	1050	6.1	1500	12400	82	25.0	1350	4.6	1500	13800	79		
	VF 130_23	23	57	39	1050	5.4	1500	13200	81	21.7	1300	3.9	1500	13800	77		
	VF 130_30	30	49	30.0	1250	5.2	—	13200	77	16.7	1500	3.7	—	13800	72		
	VF 130_40	40	44	22.5	1200	3.9	—	13200	73	12.5	1400	2.8	—	13800	68		
	VF 130_46	46	45	19.6	1150	3.3	490	13200	73	10.9	1350	2.3	1270	13800	68		
	VF 130_56	56	42	16.1	1080	2.7	1500	13200	70	8.9	1200	1.8	1500	13800	65		
	VF 130_64	64	39	14.1	1050	2.4	1500	13200	68	7.8	1200	1.6	1500	13800	62		
	VF 130_80	80	35	11.3	950	1.8	1500	13200	64	6.3	1150	1.3	1500	13800	58		
VF 130_100	100	31	9.0	800	1.3	1500	13200	59	5.0	900	0.91	1500	13800	54			

1800 Nm

			$i$	$\eta_s$ %	$n_1 = 2800 \text{ min}^{-1}$					$n_1 = 1400 \text{ min}^{-1}$								
					$n_2$ min <sup>-1</sup>	$M_{n2}$ Nm	$P_{n1}$ kW	$R_{n1}$ N	$R_{n2}$ N	$\eta_d$ %	$n_2$ min <sup>-1</sup>	$M_{n2}$ Nm	$P_{n1}$ kW	$R_{n1}$ N		$R_{n2}$ N	$\eta_d$ %	
<b>VFR 130</b>	VFR 130_60	60	58	47	1050	6.4	1000	12400	81	23.3	1350	4.3	1000	13800	78	189		
	VFR 130_69	69	56	41	1050	5.6	1000	13200	80	20.3	1300	3.7	1000	13800	76			
	VFR 130_90	90	48	31	1250	5.4	1000	13200	76	15.6	1500	3.5	1000	13800	71			
	VFR 130_120	120	43	23.3	1200	4.1	1000	13200	72	11.7	1400	2.6	1000	13800	67			
	VFR 130_138	138	44	20.3	1150	3.4	1000	13200	72	10.1	1350	2.2	1000	13800	67			
	VFR 130_168	168	41	16.7	1080	2.7	1000	13200	69	8.3	1200	1.6	1000	13800	64			
	VFR 130_192	192	38	14.6	1050	2.4	1000	13200	67	7.3	1200	1.5	1000	13800	61			
	VFR 130_240	240	34	11.7	950	1.9	1000	13200	63	5.8	1150	1.2	1000	13800	57			
	VFR 130_300	300	30	9.3	800	1.4	1000	13200	58	4.7	900	0.83	1000	13800	53			
						$n_1 = 900 \text{ min}^{-1}$					$n_1 = 500 \text{ min}^{-1}$							
	<b>VFR 130</b>	VFR 130_60	60	58	15.0	1450	3.1	1000	13800	75	8.3	1600	1.9	1000	13800		74	189
VFR 130_69		69	56	13.0	1450	2.7	1000	13800	74	7.2	1550	1.6	1000	13800	72			
VFR 130_90		90	48	10.0	1600	2.5	1000	13800	68	5.6	1800	1.6	1000	13800	66			
VFR 130_120		120	43	7.5	1600	2.0	1000	13800	63	4.2	1800	1.3	1000	13800	61			
VFR 130_138		138	44	6.5	1500	1.6	1000	13800	64	3.6	1600	1.0	1000	13800	61			
VFR 130_168		168	41	5.4	1350	1.3	1000	13800	60	3.0	1450	0.78	1000	13800	58			
VFR 130_192		192	38	4.7	1300	1.1	1000	13800	58	2.6	1400	0.70	1000	13800	55			
VFR 130_240		240	34	3.8	1200	0.87	1000	13800	54	2.1	1250	0.54	1000	13800	51			
VFR 130_300	300	30	3.0	1000	0.64	1000	13800	49	1.7	1100	0.41	1000	13800	47				

(-) Interpellare il ns. servizio tecnico comunicando i dati relativi al carico radiale (senso di rotazione, orientamento, posizione)





## W/VF 63/130

**1850 Nm**



W/VF 63/130	i	$\eta_s$ %	$n_1 = 1400 \text{ min}^{-1}$							$n_1 = 900 \text{ min}^{-1}$					190
			$n_2$ min <sup>-1</sup>	$M_{n2}$ Nm	$P_{n1}$ kW	$R_{n1}$ N	$R_{n2}$ N	$\eta_d$ %	$n_2$ min <sup>-1</sup>	$M_{n2}$ Nm	$P_{n1}$ kW	$R_{n1}$ N	$R_{n2}$ N	$\eta_d$ %	
W/VF 63/130_280	280	31	5.0	1800	1.9	480	13800	50	3.2	1850	1.3	480	13800	48	
W/VF 63/130_400	400	29	3.5	1800	1.5	480	13800	44	2.3	1850	0.99	480	13800	44	
W/VF 63/130_600	600	26	2.3	1800	1.1	480	13800	40	1.5	1850	0.73	480	13800	40	
W/VF 63/130_760	760	24	1.8	1800	0.89	480	13800	39	1.2	1850	0.62	480	13800	37	
W/VF 63/130_960	960	23	1.5	1800	0.74	480	13800	37	0.94	1850	0.52	480	13800	35	
W/VF 63/130_1200	1200	19	1.2	1800	0.65	—	13800	34	0.75	1850	0.45	—	13800	32	
W/VF 63/130_1520	1520	18	0.92	1800	0.55	—	13800	32	0.59	1850	0.38	—	13800	30	
W/VF 63/130_1800	1800	16	0.78	1800	0.52	—	13800	28	0.50	1850	0.37	—	13800	26	
W/VF 63/130_2560	2560	14	0.55	1800	0.45	—	13800	23	0.35	1850	0.32	—	13800	21	
W/VF 63/130_3200	3200	12	0.44	1800	0.49	—	13800	17	0.28	1850	0.34	480	13800	16	

(-) Interpellare il ns. servizio tecnico comunicando i dati relativi al carico radiale (senso di rotazione, orientamento, posizione)







## VF 185 - VFR 185

**3600 Nm**

				n <sub>1</sub> = 2800 min <sup>-1</sup>					n <sub>1</sub> = 1400 min <sup>-1</sup>							
				n <sub>2</sub>	M <sub>n2</sub>	P <sub>n1</sub>	R <sub>n1</sub>	R <sub>n2</sub>	η <sub>d</sub>	n <sub>2</sub>	M <sub>n2</sub>	P <sub>n1</sub>	R <sub>n1</sub>		R <sub>n2</sub>	η <sub>d</sub>
				min <sup>-1</sup>	Nm	kW	N	N	%	min <sup>-1</sup>	Nm	kW	N		N	%
<b>VF 185</b>	<b>VF 185_7</b>	7	72	400	1313	60	2800	4670	91	200	1750	41	2800	5570	90	188
	<b>VF 185_10</b>	10	68	280	1365	44	2800	7390	90	140	1820	30	2800	8960	89	
	<b>VF 185_15</b>	15	66	187	1388	30	2800	9460	89	93	1850	21	2800	11600	88	
	<b>VF 185_20</b>	20	59	140	1703	28	2800	10500	88	70	2270	19.6	2800	12900	85	
	<b>VF 185_30</b>	30	54	93	1485	16.9	2800	13700	86	47	1980	11.8	2800	16900	83	
	<b>VF 185_40</b>	40	44	70	1973	17.6	—	14500	82	35	2630	12.4	—	17900	78	
	<b>VF 185_50</b>	50	41	56	1875	13.7	—	16300	80	28.0	2500	9.8	—	18000	76	
	<b>VF 185_60</b>	60	39	47	1703	10.7	2800	18000	78	23.3	2270	7.6	770	18000	74	
	<b>VF 185_80</b>	80	33	35	1590	7.8	2800	18000	75	17.5	2120	5.6	1140	18000	69	
	<b>VF 185_100</b>	100	30	28.0	1425	5.8	2800	18000	72	14.0	1900	4.3	2800	18000	65	
				n <sub>1</sub> = 900 min <sup>-1</sup>					n <sub>1</sub> = 500 min <sup>-1</sup>							
<b>VF 185</b>	<b>VF 185_7</b>	7	72	129	2000	30	2800	7120	89	71	2450	21	2800	8730	88	188
	<b>VF 185_10</b>	10	68	90	2150	23	2800	10200	88	50	2600	16.0	2800	12500	86	
	<b>VF 185_15</b>	15	66	60	2250	16.4	2800	13100	86	33	2800	11.8	2800	15700	84	
	<b>VF 185_20</b>	20	59	45	2750	15.6	2800	14600	84	25.0	3300	10.9	2800	17900	81	
	<b>VF 185_30</b>	30	54	30.0	2400	9.4	2800	19000	81	16.7	2800	6.5	2800	19500	77	
	<b>VF 185_40</b>	40	44	22.5	3100	9.7	—	19000	76	12.5	3600	6.8	—	19500	71	
	<b>VF 185_50</b>	50	41	18.0	2900	7.6	—	19000	73	10.0	3300	5.2	—	19500	68	
	<b>VF 185_60</b>	60	39	15.0	2600	5.8	700	19000	71	8.3	3000	4.2	2800	19500	66	
	<b>VF 185_80</b>	80	33	11.3	2400	4.3	1770	19000	66	6.3	2800	3.2	2800	19500	60	
	<b>VF 185_100</b>	100	30	9.0	2000	3.0	2800	19000	62	5.0	2300	2.1	2800	19500	56	

**4200 Nm**

				n <sub>1</sub> = 2800 min <sup>-1</sup>					n <sub>1</sub> = 1400 min <sup>-1</sup>									
				n <sub>2</sub>	M <sub>n2</sub>	P <sub>n1</sub>	R <sub>n1</sub>	R <sub>n2</sub>	η <sub>d</sub>	n <sub>2</sub>	M <sub>n2</sub>	P <sub>n1</sub>	R <sub>n1</sub>		R <sub>n2</sub>	η <sub>d</sub>		
				min <sup>-1</sup>	Nm	kW	N	N	%	min <sup>-1</sup>	Nm	kW	N		N	%		
<b>VFR 185</b>	<b>VFR 185_90</b>	90	53	31	2400	9.9	1700	19000	80	15.6	2800	6.0	1700	19500	76	189		
	<b>VFR 185_120</b>	120	43	23.3	3100	10.2	1700	19000	75	11.7	3600	6.3	1700	19500	70			
	<b>VFR 185_150</b>	150	40	18.7	2900	7.9	1700	19000	72	9.3	3300	4.8	1700	19500	67			
	<b>VFR 185_180</b>	180	38	15.6	2600	6.1	1700	19000	70	7.8	3000	3.8	1700	19500	65			
	<b>VFR 185_240</b>	240	32	11.7	2400	4.5	1700	19000	65	5.8	2800	2.9	1700	19500	59			
	<b>VFR 185_300</b>	300	29	9.3	2000	3.2	1700	19000	61	4.7	2300	2.0	1700	19500	55			
					n <sub>1</sub> = 900 min <sup>-1</sup>					n <sub>1</sub> = 500 min <sup>-1</sup>								
	<b>VFR 185</b>	<b>VFR 185_90</b>	90	53	10.0	3200	4.6	1700	19500	73	5.6	3500	2.9	1700	19500		71	189
		<b>VFR 185_120</b>	120	43	7.5	3800	4.5	1700	19500	66	4.2	4200	2.9	1700	19500		63	
		<b>VFR 185_150</b>	150	40	6.0	3400	3.4	1700	19500	63	3.3	3700	2.2	1700	19500		60	
<b>VFR 185_180</b>		180	38	5.0	3300	2.9	1700	19500	60	2.8	3600	1.8	1700	19500	57			
<b>VFR 185_240</b>		240	32	3.8	2800	2.0	1700	19500	54	2.1	2900	1.2	1700	19500	53			
<b>VFR 185_300</b>		300	29	3.0	2400	1.5	1700	19500	50	1.7	2500	0.91	1700	19500	48			

(-) Interpellare il ns. servizio tecnico comunicando i dati relativi al carico radiale (senso di rotazione, orientamento, posizione)





## VF 210 - VFR 210

5000 Nm

			$i$	$\eta_s$ %	$n_1 = 2800 \text{ min}^{-1}$					$n_1 = 1400 \text{ min}^{-1}$							
					$n_2$ min <sup>-1</sup>	$M_{n2}$ Nm	$P_{n1}$ kW	$R_{n1}$ N	$R_{n2}$ N	$\eta_d$ %	$n_2$ min <sup>-1</sup>	$M_{n2}$ Nm	$P_{n1}$ kW	$R_{n1}$ N		$R_{n2}$ N	$\eta_d$ %
<b>VF 210</b>	VF 210_7	7	71	400	1725	79	5300	14000	91	200	2300	54	5300	16700	90	188	
	VF 210_10	10	69	280	1988	65	5300	16300	90	140	2650	44	5300	19500	89		
	VF 210_15	15	63	187	2138	47	5300	19700	89	93	2850	32	5300	23700	88		
	VF 210_20	20	57	140	2325	39	4970	22000	87	70	3100	27	1100	26600	85		
	VF 210_30	30	51	93	2288	26	5300	25900	85	47	3050	18.5	1760	31500	83		
	VF 210_40	40	42	70	2625	23	—	28300	81	35	3500	17.0	—	31500	78		
	VF 210_50	50	39	56	2475	18.4	—	31000	79	28.0	3300	13.0	—	31500	76		
	VF 210_60	60	36	47	2363	15.0	—	31500	77	23.3	3015	10.0	—	31500	73		
	VF 210_80	80	31	35	2175	10.9	—	31500	73	17.5	2900	7.7	—	31500	69		
	VF 210_100	100	27	28	2025	8.5	950	31500	70	14.0	2700	6.0	—	31500	65		
					$n_1 = 900 \text{ min}^{-1}$					$n_1 = 500 \text{ min}^{-1}$							
<b>VF 210</b>	VF 210_7	7	71	129	2700	41	5300	18800	89	71	3400	29	5300	21800	88	188	
	VF 210_10	10	69	90	3150	34	5300	21900	88	50	3800	23	5300	26000	87		
	VF 210_15	15	63	60	3300	24	5300	27000	86	33	4100	17.2	5300	31800	84		
	VF 210_20	20	57	45	3800	22	—	29900	83	25.0	4700	15.4	—	34500	81		
	VF 210_30	30	51	30.0	3400	13.4	3750	33000	80	16.7	4000	9.3	5300	34500	77		
	VF 210_40	40	42	22.5	4300	13.5	—	33000	75	12.5	5000	9.4	—	34500	71		
	VF 210_50	50	39	18.0	4000	10.5	—	33000	72	10.0	4500	7.1	—	34500	68		
	VF 210_60	60	36	15.0	3720	8.5	—	33000	70	8.3	4300	6.0	—	34500	65		
	VF 210_80	80	31	11.3	3300	6.0	—	33000	65	6.3	3900	4.4	—	34500	60		
	VF 210_100	100	27	9.0	3000	4.6	—	33000	61	5.0	3400	3.4	1470	34500	56		

6300 Nm

			$i$	$\eta_s$ %	$n_1 = 2800 \text{ min}^{-1}$					$n_1 = 1400 \text{ min}^{-1}$							
					$n_2$ min <sup>-1</sup>	$M_{n2}$ Nm	$P_{n1}$ kW	$R_{n1}$ N	$R_{n2}$ N	$\eta_d$ %	$n_2$ min <sup>-1</sup>	$M_{n2}$ Nm	$P_{n1}$ kW	$R_{n1}$ N		$R_{n2}$ N	$\eta_d$ %
<b>VFR 210</b>	VFR 210_30	30	68	93	3150	36	1800	22100	87	47	3800	21.8	2200	27400	86	189	
	VFR 210_45	45	62	62	3300	25	1800	27000	85	31	4100	16.2	2200	33200	83		
	VFR 210_60	60	56	47	3800	22	1800	29900	82	23.0	4700	14.5	2200	34500	80		
	VFR 210_90	90	50	31	3400	14.1	1800	33000	79	15.6	4000	8.6	2200	34500	76		
	VFR 210_120	120	41	23.3	4300	14.3	1800	33000	74	11.7	5000	8.8	2200	34500	70		
	VFR 210_150	150	38	18.7	4000	11.1	1800	33000	71	9.3	4500	6.6	2200	34500	67		
	VFR 210_180	180	35	15.6	3720	8.8	1800	33000	69	7.8	4300	5.5	2200	34500	64		
	VFR 210_240	240	30	11.7	3300	6.3	1800	33000	64	5.8	3900	4.1	2200	34500	59		
	VFR 210_300	300	26	9.3	3000	4.9	1800	33000	60	4.7	3400	3.0	2200	34500	55		
						$n_1 = 900 \text{ min}^{-1}$					$n_1 = 500 \text{ min}^{-1}$						
<b>VFR 210</b>	VFR 210_30	30	68	30.0	4800	18.1	2300	30100	84	16.7	5500	11.8	2650	34500	82	189	
	VFR 210_45	45	62	20.0	4900	12.9	2300	34500	80	11.1	5600	8.4	2650	34500	78		
	VFR 210_60	60	56	15.0	5400	11.1	2300	34500	77	8.3	6000	7.1	2650	34500	74		
	VFR 210_90	90	50	10.0	4600	6.7	2300	34500	72	5.6	5150	4.3	2650	34500	70		
	VFR 210_120	120	41	7.5	5900	7.1	2300	34500	66	4.2	6300	4.4	2650	34500	63		
	VFR 210_150	150	38	6.0	5300	5.4	2300	34500	62	3.3	5900	3.5	2650	34500	59		
	VFR 210_180	180	35	5.0	4900	4.4	2300	34500	59	2.8	5400	2.8	2650	34500	56		
	VFR 210_240	240	30	3.8	4400	3.2	2300	34500	54	2.1	4800	2.1	2650	34500	50		
VFR 210_300	300	26	3.0	3600	2.3	2300	34500	49	1.7	4000	1.5	2650	34500	46			

(-) Interpellare il ns. servizio tecnico comunicando i dati relativi al carico radiale (senso di rotazione, orientamento, posizione)



## VF/VF 130/210

**6500 Nm**

		i	η <sub>s</sub> %	n <sub>1</sub> = 1400 min <sup>-1</sup>					n <sub>1</sub> = 900 min <sup>-1</sup>							
				n <sub>2</sub> min <sup>-1</sup>	M <sub>n2</sub> Nm	P <sub>n1</sub> kW	R <sub>n1</sub> N	R <sub>n2</sub> N	η <sub>d</sub> %	n <sub>2</sub> min <sup>-1</sup>	M <sub>n2</sub> Nm	P <sub>n1</sub> kW	R <sub>n1</sub> N		R <sub>n2</sub> N	η <sub>d</sub> %
				<b>VF/VF 130/210</b>	<b>VF/VF 130/210_280</b>	280	30	5.0	6300	6.3	1500	34500	52		3.2	6500
<b>VF/VF 130/210_400</b>	400	28	3.5	6300	4.6	1500	34500	50	2.3	6500	3.2	1500	34500	48		
<b>VF/VF 130/210_600</b>	600	26	2.3	6300	3.6	1500	34500	43	1.5	6500	2.4	1500	34500	43		
<b>VF/VF 130/210_800</b>	800	25	1.8	6300	2.8	1500	34500	41	1.1	6500	2.0	1500	34500	38		
<b>VF/VF 130/210_920</b>	920	24	1.5	6300	2.7	1500	34500	37	1.0	6500	1.9	1500	34500	35		
<b>VF/VF 130/210_1200</b>	1200	21	1.2	6300	2.2	—	34500	35	0.75	6500	1.5	—	34500	34		
<b>VF/VF 130/210_1600</b>	1600	18	0.88	6300	1.8	—	34500	32	0.56	6500	1.2	—	34500	32		
<b>VF/VF 130/210_1840</b>	1840	19	0.76	6300	1.7	—	34500	30	0.49	6500	1.2	490	34500	28		
<b>VF/VF 130/210_2560</b>	2560	16	0.55	6300	1.5	1220	34500	24	0.35	6500	1.0	1500	34500	24		
<b>VF/VF 130/210_3200</b>	3200	15	0.44	6300	1.3	1500	34500	22	0.28	6500	0.96	1500	34500	20		

(-) Interpellare il ns. servizio tecnico comunicando i dati relativi al carico radiale (senso di rotazione, orientamento, posizione)



## VF 250 - VFR 250

7100 Nm

				n <sub>1</sub> = 2800 min <sup>-1</sup>					n <sub>1</sub> = 1400 min <sup>-1</sup>							
				n <sub>2</sub>	M <sub>n2</sub>	P <sub>n1</sub>	R <sub>n1</sub>	R <sub>n2</sub>	η <sub>d</sub>	n <sub>2</sub>	M <sub>n2</sub>	P <sub>n1</sub>	R <sub>n1</sub>		R <sub>n2</sub>	η <sub>d</sub>
				min <sup>-1</sup>	Nm	kW	N	N	%	min <sup>-1</sup>	Nm	kW	N		N	%
<b>VF 250</b>	VF 250_7	7	71	400	2400	109	7000	18300	92	200	3200	75	7000	21900	91	188
	VF 250_10	10	69	280	2775	89	7000	21100	91	140	3700	61	7000	25300	90	
	VF 250_15	15	64	187	3000	65	7000	25100	90	93	4000	45	7000	30300	88	
	VF 250_20	20	59	140	3338	56	7000	28000	88	70	4450	38	7000	33900	86	
	VF 250_30	30	53	93	3000	34	7000	33400	86	47	4000	23	7000	40600	84	
	VF 250_40	40	41	70	3600	32	4680	36200	82	35	4800	22	—	44000	79	
	VF 250_50	50	36	56	3375	25	6370	39500	79	28.0	4500	17.0	—	47000	76	
	VF 250_60	60	38	47	3375	20.6	7000	42100	80	23.3	4500	15.0	—	47000	76	
	VF 250_80	80	32	35	2925	14.1	7000	47000	76	17.5	3900	10.0	—	47000	71	
	VF 250_100	100	29	28	2738	11.0	7000	47000	73	14.0	3650	7.8	3010	47000	68	
				n <sub>1</sub> = 900 min <sup>-1</sup>					n <sub>1</sub> = 500 min <sup>-1</sup>							
<b>VF 250</b>	VF 250_7	7	71	129	4150	63	7000	23700	90	71	5200	44	7000	27600	88	188
	VF 250_10	10	69	90	4800	51	7000	27600	89	50	6000	36	7000	32300	87	
	VF 250_15	15	64	60	5300	39	7000	33200	87	33	6400	27	7000	39500	85	
	VF 250_20	20	59	45	5950	33	1640	37200	85	25.0	7100	24	1910	44400	82	
	VF 250_30	30	53	30.0	5500	21	7000	44900	81	16.7	6000	14.7	7000	52000	79	
	VF 250_40	40	41	22.5	6500	20.0	—	48800	76	12.5	7000	13.6	—	52000	72	
	VF 250_50	50	36	18.0	6200	16.2	—	50000	73	10.0	6500	11.1	—	52000	68	
	VF 250_60	60	38	15.0	5600	12.2	—	50000	72	8.3	6300	8.6	4350	52000	68	
	VF 250_80	80	32	11.3	5200	9.3	—	50000	67	6.3	5400	6.8	7000	52000	62	
	VF 250_100	100	29	9.0	4800	7.2	3010	50000	63	5.0	5000	5.3	4160	52000	58	

9000 Nm

				n <sub>1</sub> = 2800 min <sup>-1</sup>					n <sub>1</sub> = 1400 min <sup>-1</sup>							
				n <sub>2</sub>	M <sub>n2</sub>	P <sub>n1</sub>	R <sub>n1</sub>	R <sub>n2</sub>	η <sub>d</sub>	n <sub>2</sub>	M <sub>n2</sub>	P <sub>n1</sub>	R <sub>n1</sub>		R <sub>n2</sub>	η <sub>d</sub>
				min <sup>-1</sup>	Nm	kW	N	N	%	min <sup>-1</sup>	Nm	kW	N		N	%
<b>VFR 250</b>	VFR 250_30	30	68	93	4800	54	2800	27800	89	47	6000	34	3500	34000	86	189
	VFR 250_45	45	63	62	5300	41	2800	33300	87	31	6400	25	3500	41300	84	
	VFR 250_60	60	58	47	5950	35	2800	37200	85	23.0	7100	21	3500	46100	81	
	VFR 250_90	90	52	31	5500	22	2800	44700	81	15.6	6000	12.6	3500	52000	78	
	VFR 250_120	120	40	23.3	6500	21.3	2800	48500	76	11.7	7000	12.1	3500	52000	71	
	VFR 250_150	150	35	18.7	6200	16.9	2800	50000	73	9.3	6500	9.5	3500	52000	67	
	VFR 250_180	180	37	15.6	5600	12.9	2800	50000	72	7.8	6300	7.7	3500	52000	67	
	VFR 250_240	240	31	11.7	5200	9.7	2800	50000	67	5.8	5400	5.4	3500	52000	61	
	VFR 250_300	300	28	9.3	4800	7.6	2800	50000	63	4.7	5000	4.3	3500	52000	57	
					n <sub>1</sub> = 900 min <sup>-1</sup>					n <sub>1</sub> = 500 min <sup>-1</sup>						
<b>VFR 250</b>	VFR 250_30	30	68	30.0	6500	24	3700	39600	84	16.7	7600	16.1	4200	47600	83	189
	VFR 250_45	45	63	20.0	6800	17.5	3700	48000	82	11.1	7900	11.6	3500	52000	80	
	VFR 250_60	60	58	15.0	7600	15.2	3700	52000	79	8.3	8600	9.9	3500	52000	76	
	VFR 250_90	90	52	10.0	6500	9.3	3700	52000	74	5.6	7400	6.1	3500	52000	71	
	VFR 250_120	120	40	7.5	7500	8.8	3700	52000	67	4.2	9000	6.2	3500	52000	64	
	VFR 250_150	150	35	6.0	7000	7.0	3700	52000	63	3.3	8600	5.1	3500	52000	59	
	VFR 250_180	180	37	5.0	6700	5.7	3700	52000	62	2.8	7600	3.8	3500	52000	59	
	VFR 250_240	240	31	3.8	5800	4.1	3700	52000	56	2.1	6500	2.7	3500	52000	52	
VFR 250_300	300	28	3.0	5300	3.2	3700	52000	52	1.7	6000	2.2	3500	52000	48		

(-) Interpellare il ns. servizio tecnico comunicando i dati relativi al carico radiale (senso di rotazione, orientamento, posizione)





## VF/VF 130/250

9200 Nm

		i	η <sub>s</sub> %	n <sub>1</sub> = 1400 min <sup>-1</sup>					n <sub>1</sub> = 900 min <sup>-1</sup>							
				n <sub>2</sub> min <sup>-1</sup>	M <sub>n2</sub> Nm	P <sub>n1</sub> kW	R <sub>n1</sub> N	R <sub>n2</sub> N	η <sub>d</sub> %	n <sub>2</sub> min <sup>-1</sup>	M <sub>n2</sub> Nm	P <sub>n1</sub> kW	R <sub>n1</sub> N		R <sub>n2</sub> N	η <sub>d</sub> %
<b>VF/VF 130/250</b>	<b>VF/VF 130/250_280</b>	280	29	5.0	9000	8.9	1500	52000	53	3.2	9200	6.1	1500	52000	51	190
	<b>VF/VF 130/250_400</b>	400	27	3.5	9000	6.7	1500	52000	49	2.3	9200	4.6	1500	52000	47	
	<b>VF/VF 130/250_600</b>	600	26	2.3	9000	5.0	1500	52000	44	1.5	9200	3.4	1500	52000	43	
	<b>VF/VF 130/250_800</b>	800	24	1.8	9000	3.9	1500	52000	42	1.1	9200	2.7	1500	52000	40	
	<b>VF/VF 130/250_920</b>	920	23	1.5	9000	3.9	1500	52000	37	0.98	9200	2.7	1500	52000	35	
	<b>VF/VF 130/250_1200</b>	1200	20	1.2	9000	3.1	—	52000	35	0.75	9200	2.2	—	52000	33	
	<b>VF/VF 130/250_1600</b>	1600	18	0.88	9000	2.6	—	52000	32	0.56	9200	1.8	—	52000	30	
	<b>VF/VF 130/250_1840</b>	1840	18	0.76	9000	2.3	—	52000	31	0.49	9200	1.6	490	52000	29	
	<b>VF/VF 130/250_2560</b>	2560	16	0.55	9000	2.1	1500	52000	25	0.35	9200	1.5	1500	52000	23	
	<b>VF/VF 130/250_3200</b>	3200	14	0.44	9000	2.0	1500	52000	21	0.28	9200	1.4	1500	52000	19	

(-) Interpellare il ns. servizio tecnico comunicando i dati relativi al carico radiale (senso di rotazione, orientamento, posizione)



## 23 COMBINAZIONI DEI RAPPORTI NEI RIDUTTORI COMBINATI SERIE VF/VF, VF/W, W/VF

	Rapporti										i max	
<b>VF/VF 30/44</b>	<b>245</b>	<b>350</b>	<b>420</b>	<b>560</b>	<b>700</b>	<b>840</b>	<b>1120</b>	<b>1680</b>	<b>2100</b>			<b>6000</b>
<b>VF 30</b>	7	10	15	20	20	30	40	60	60			60
<b>VF 44</b>	35	35	28	28	35	28	28	28	35			100
<b>VF/VF 30/49</b>	<b>240</b>	<b>315</b>	<b>420</b>	<b>540</b>	<b>720</b>	<b>900</b>	<b>1120</b>	<b>1440</b>	<b>2160</b>	<b>2700</b>		<b>6000</b>
<b>VF 30</b>	10	7	15	15	20	20	40	40	60	60		60
<b>VF 49</b>	24	45	28	36	36	45	28	36	36	45		100
<b>VF/W 30/63</b>	<b>240</b>	<b>315</b>	<b>450</b>	<b>570</b>	<b>720</b>	<b>900</b>	<b>1200</b>	<b>1520</b>	<b>2280</b>	<b>2700</b>		<b>7000</b>
<b>VF 30</b>	10	7	15	15	30	30	40	40	60	60		70
<b>W 63</b>	24	45	30	38	24	30	30	38	38	45		100
<b>VF/W 44/75</b>	<b>250</b>	<b>300</b>	<b>400</b>	<b>525</b>	<b>700</b>	<b>920</b>	<b>1200</b>	<b>1500</b>	<b>2100</b>	<b>2800</b>		<b>10000</b>
<b>VF 44</b>	10	10	10	35	35	46	60	60	70	70		100
<b>W 75</b>	25	30	40	15	20	20	20	25	30	40		100
<b>VF/W 44/86</b>	<b>230</b>	<b>300</b>	<b>400</b>	<b>525</b>	<b>700</b>	<b>920</b>	<b>1380</b>	<b>1840</b>	<b>2116</b>	<b>2760</b>		<b>10000</b>
<b>VF 44</b>	10	10	10	35	35	46	46	46	46	60		100
<b>W 86</b>	23	30	40	15	20	20	30	40	46	46		100
<b>VF/W 49/110</b>	<b>230</b>	<b>300</b>	<b>400</b>	<b>540</b>	<b>720</b>	<b>1080</b>	<b>1350</b>	<b>1656</b>	<b>2070</b>	<b>2800</b>		<b>10000</b>
<b>VF 49</b>	10	10	10	18	36	36	45	36	45	70		100
<b>W 110</b>	23	30	40	30	20	30	30	46	46	40		100
<b>W/VF 63/130</b>	<b>280</b>	<b>400</b>	<b>600</b>	<b>760</b>	<b>960</b>	<b>1200</b>	<b>1520</b>	<b>1800</b>	<b>2560</b>	<b>3200</b>		<b>10000</b>
<b>W 63</b>	7	10	15	19	24	30	38	45	64	80		100
<b>VF 130</b>	40	40	40	40	40	40	40	40	40	40		100
<b>W/VF 86/150</b>	<b>200</b>	<b>225</b>	<b>300</b>	<b>345</b>	<b>460</b>	<b>529</b>	<b>690</b>	<b>920</b>	<b>1380</b>	<b>1840</b>	<b>2944</b>	<b>10000</b>
<b>W 86</b>	10	15	15	15	20	23	23	23	46	46	64	100
<b>VF 150</b>	20	15	20	23	23	23	30	40	30	40	46	100
<b>W/VF 86/185</b>	<b>280</b>	<b>400</b>	<b>600</b>	<b>800</b>	<b>920</b>	<b>1200</b>	<b>1600</b>	<b>1840</b>	<b>2560</b>	<b>3200</b>		<b>10000</b>
<b>W 86</b>	7	10	15	20	23	30	40	46	64	80		100
<b>VF 185</b>	40	40	40	40	40	40	40	40	40	40		100
<b>VF/VF 130/210</b>	<b>280</b>	<b>400</b>	<b>600</b>	<b>800</b>	<b>920</b>	<b>1200</b>	<b>1600</b>	<b>1840</b>	<b>2560</b>	<b>3200</b>		<b>10000</b>
<b>VF 130</b>	7	10	15	20	23	30	40	46	64	80		100
<b>VF 210</b>	40	40	40	40	40	40	40	40	40	40		100
<b>VF/VF 130/250</b>	<b>280</b>	<b>400</b>	<b>600</b>	<b>800</b>	<b>920</b>	<b>1200</b>	<b>1600</b>	<b>1840</b>	<b>2560</b>	<b>3200</b>		<b>10000</b>
<b>VF 130</b>	7	10	15	20	23	30	40	46	64	80		100
<b>VF 250</b>	40	40	40	40	40	40	40	40	40	40		100

Le combinazioni dei rapporti rappresentati in tabella sono quelle preferenziali, e suggerite dal costruttore.

Il servizio tecnico di Bonfiglioli potrà eventualmente considerare le richieste di combinazioni di rapporti diverse da quelle proposte, purchè inferiori al valore massimo indicato in tabella.

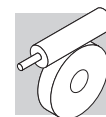

## 24 PREDISPOSIZIONI MOTORE

### 24.1 Motori standard IEC

Nelle tabelle vengono riportati gli abbinamenti motore possibili in termini puramente geometrici. La scelta del motoriduttore deve essere effettuata seguendo le istruzioni specificate al paragrafo: “Selezione”, rispettando in particolare la condizione  $S \geq f_s$ .

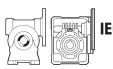
 IEC	VF 27	VF 30	VF 44	VF 49	W 63	W 75	W 86	W 110	VF 130	VF 150	VF 185	VF 210	VF 250
<b>P27</b> —	7...70	—	—	—	—	—	—	—	—	—	—	—	—
<b>P56</b> $\frac{B5}{B14}$	—	7...70	—	—	—	—	—	—	—	—	—	—	—
<b>P63</b> $\frac{B5}{B14}$	—	7...60	7...100	7...100	—	—	—	—	—	—	—	—	—
<b>P71</b> $\frac{B5}{B14}$	—	—	7...35	7...60	7...100	$\frac{7...100}{—}$	$\frac{7...100}{—}$	—	—	—	—	—	—
<b>P80</b> $\frac{B5}{B14}$	—	—	—	7...28	7...100	7...100	7...100	7...100	—	—	—	—	—
<b>P90</b> $\frac{B5}{B14}$	—	—	—	—	7...30	7...100	7...100	7...100	$\frac{46...100}{—}$	—	—	—	—
<b>P100</b> $\frac{B5}{B14}$	—	—	—	—	—	7...100	7...100	7...100	$\frac{7...80}{—}$	$\frac{23...100}{—}$	$\frac{50...100}{—}$	—	—
<b>P112</b> $\frac{B5}{B14}$	—	—	—	—	—	7...100	7...100	7...100	$\frac{7...80}{—}$	$\frac{23...100}{—}$	$\frac{50...100}{—}$	—	—
<b>P132</b> B5	—	—	—	—	—	—	—	7...100	7...40 #	7...46	30...80	7...100	7...100
<b>P160</b> B5	—	—	—	—	—	—	—	—	—	7...20 #	15...40	7...100	7...100
<b>P180</b> B5	—	—	—	—	—	—	—	—	—	—	7...20 #	7...100	7...100
<b>P200</b> B5	—	—	—	—	—	—	—	—	—	—	—	7...100	7...100
<b>P225</b> B5	—	—	—	—	—	—	—	—	—	—	—	7...100	7...100

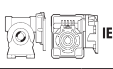
 IEC	VFR 44	VFR 49	WR 63	WR 75	WR 86	WR 110	VFR 130	VFR 150	VFR 185	VFR 210	VFR 250
<b>S44</b> —	70...500	—	—	—	—	—	—	—	—	—	—
<b>P63</b> B5	—	30...300	21...300	21...300	21...300	—	—	—	—	—	—
<b>P71</b> B5	—	—	21...300	21...300	21...300	21...300	—	—	—	—	—
<b>P80</b> B5	—	—	—	21...300	21...300	21...300	30...300	—	—	—	—
<b>P90</b> B5	—	—	—	15...150	15...150	21...300	30...300	$\frac{30...300}{\ominus(37.5;50)}$	$\frac{30...300}{\ominus(37.5;50)}$ $\frac{\ominus(75;100)}{\ominus(75;100)}$	—	—
<b>P100</b> B5	—	—	—	—	—	21...300	30...300 #	$\frac{30...300}{\ominus(37.5;50)}$	$\frac{30...300}{\ominus(37.5;50)}$ $\frac{\ominus(75;100)}{\ominus(75;100)}$	30...300	30...300
<b>P112</b> B5	—	—	—	—	—	21...300	30...300 #	$\frac{30...300}{\ominus(37.5;50)}$	$\frac{30...300}{\ominus(37.5;50)}$ $\frac{\ominus(75;100)}{\ominus(75;100)}$	30...300	30...300
<b>P132</b> B5	—	—	—	—	—	—	—	$\frac{25...50 \#}{\ominus(30;45)}$	$\frac{25...100 \#}{\ominus(30;45)}$ $\frac{\ominus(60;90)}{\ominus(60;90)}$	30...300	30...300
<b>P160</b> B5	—	—	—	—	—	—	—	—	—	30...300 #	30...300 #

■ Rapporto della precoppia elicoidale  $i = 1.5$

# Gli accoppiamenti motore-riduttore marcati con [#] sono realizzati tramite linguette di tipo ribassato, fornite insieme al riduttore stesso.



IEC		VF/VF 30/44	VF/VF 30/49	VF/W 30/63	VF/W 44/75	VF/W 44/86	VF/W 49/110	W/VF 63/130	W/VF 86/150	W/VF 86/185	VF/VF 130/210	VF/VF 130/250
<b>P56</b>	B5	—	—	240...2700	—	—	—	—	—	—	—	—
	B14	245...2100	240...2700	240...2700	—	—	—	—	—	—	—	—
<b>P63</b>	B5	—	—	240...2700	—	—	—	—	—	—	—	—
	B14	245...2100	240...2700	240...2700	250...2800	230...2760	230...2800	—	—	—	—	—
<b>P71</b>	B5	—	—	—	250...700	230...700	230...2400	280...3200	200...2944	280...3200	—	—
	B14	—	—	—	—	—	—	—	—	—	—	—
<b>P80</b>	B5	—	—	—	—	—	230...540	280...3200	200...2944	280...3200	—	—
	B14	—	—	—	—	—	—	—	—	—	—	—
<b>P90</b>	B5	—	—	—	—	—	—	280...1200	200...2944	280...3200	280...3200	280...3200
	B14	—	—	—	—	—	—	—	—	—	—	—
<b>P100</b>	B5	—	—	—	—	—	—	—	200...2944	280...3200	280...3200	280...3200
	B14	—	—	—	—	—	—	—	—	—	—	—
<b>P112</b>	B5	—	—	—	—	—	—	—	200...2944	280...3200	280...3200	280...3200
	B14	—	—	—	—	—	—	—	—	—	—	—
<b>P132</b>	B5	—	—	—	—	—	—	—	—	—	280...1600 #	280...1600 #

# Gli accoppiamenti motore-riduttore marcati con [#] sono realizzati tramite linguette di tipo ribassato, fornite insieme al riduttore stesso.

## 24.2 Motori compatti

	M1 - ME1 MXN10	M2 - ME2 MX2 - MXN20	ME3 MX3		M1 - ME1 MXN10	M2 - ME2 MX2 - MXN20	ME3 MX3
<b>W 63</b>	7 ... 100	7 ... 100	☐		<b>W/VF 63/130</b>	280 ... 3200	280 ... 3200
<b>W 75</b>	7 ... 100	7 ... 100	7 ... 100		<b>W/VF 86/150</b>	200 ... 2944	200 ... 2944
<b>W 86</b>	7 ... 100	7 ... 100	7 ... 100		<b>W/VF 86/185</b>	280 ... 3200	280 ... 3200
<b>W 110</b>	☐	7 ... 100	7 ... 100				

## 24.3 Massima potenza installabile sull'ingresso P\_

		IEC_																			
		P63			P71			P80				P90				P100			P112		
		BN	BE	BXN	BN	BE	BXN	BN	BE	BX	BXN	BN	BE	BX	BXN	BN	BE	BX	BN	BE	BX
[kW]	2p	0.37	—	—	0.75	—	—	1.5	1.1	—	—	2.2	2.2	—	—	4	3	—	4	4	—
	4p	0.25	0.18	0.18	0.55	0.37	0.37	1.1	0.75	0.75	0.75	1.85	1.5	1.5	1.5	3	3	3	4	4	4
	6p	0.12	—	—	0.37	—	—	0.75	—	—	—	1.1	0.75	—	—	1.85	1.5	—	2.2	2.2	—
		P132			P160			P180			P200		P225								
		BN	BE	BX	BN	BE	BX	BN	BE	BX	BN	IEC	BN	IEC							
[kW]	2p	9.2	9.2	—	18.5	18.5	—	22	—	—	30	45	30	45							
	4p	9.2	9.2	7.5	15	15	15	22	22	22	30	45	30	45							
	6p	5.5	4	—	11	7.5	—	15	—	—	18.5	30	18.5	30							

## 24.4 Motori non normalizzati

Per l'accoppiamento a motori elettrici non normalizzati, l'interfaccia motore dei riduttori serie VF e W può essere configurata con combinazioni albero veloce/flangia ibride, non corrispondenti cioè alla normativa IEC. La combinazione albero/flangia è esplicitata mediante i rispettivi diametri e qui di seguito esemplificata.

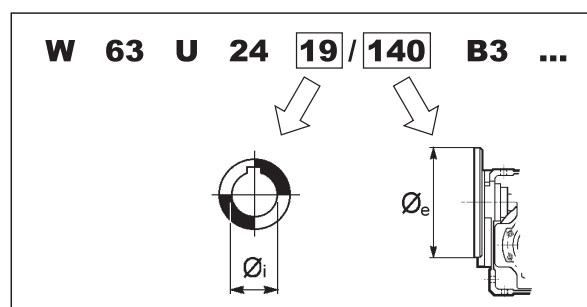



Gli abbinamenti albero/flangia disponibili, e i rapporti di trasmissione ai quali sono limitati, sono riportati nella tabella seguente.

		80	90	105	120	140	160	200
VF 30	9		$7 \leq i \leq 70$	⊖		$7 \leq i \leq 70$	⊖	⊖
	11	$7 \leq i \leq 60$		⊖	$7 \leq i \leq 60$		⊖	⊖
VF 44	HS	⊖	$7 \leq i \leq 100$	$7 \leq i \leq 100$	⊖	$7 \leq i \leq 100$	$7 \leq i \leq 100$	⊖
	11	⊖		$7 \leq i \leq 100$	⊖		$7 \leq i \leq 100$	⊖
	14	⊖	$7 \leq i \leq 35$		⊖	$7 \leq i \leq 35$		⊖
VF 49	HS	⊖	$7 \leq i \leq 100$	$7 \leq i \leq 100$	$7 \leq i \leq 100$	$7 \leq i \leq 100$	$7 \leq i \leq 100$	$7 \leq i \leq 100$
	11	⊖		$7 \leq i \leq 100$	$7 \leq i \leq 100$		$7 \leq i \leq 100$	$7 \leq i \leq 100$
	14	⊖	$7 \leq i \leq 60$		$7 \leq i \leq 60$	$7 \leq i \leq 60$		$7 \leq i \leq 60$
	19	⊖	$7 \leq i \leq 28$	$7 \leq i \leq 28$		$7 \leq i \leq 28$	$7 \leq i \leq 28$	
W 63	19	⊖	⊖	⊖	⊖	$7 \leq i \leq 100$	⊖	
W 75	14	⊖	⊖	⊖	⊖	⊖		$7 \leq i \leq 100$
	19	⊖	⊖	⊖		$7 \leq i \leq 100$	$7 \leq i \leq 100$	
	24	⊖	⊖	⊖	$7 \leq i \leq 100$		$7 \leq i \leq 100$	
W 86	14	⊖	⊖	⊖	⊖	⊖		$7 \leq i \leq 100$
	19	⊖	⊖	⊖		$7 \leq i \leq 100$	$7 \leq i \leq 100$	
	24	⊖	⊖	⊖	$7 \leq i \leq 100$		$7 \leq i \leq 100$	
W 110	19	⊖	⊖	⊖		$7 \leq i \leq 100$	⊖	⊖
	24	⊖	⊖	⊖	$7 \leq i \leq 100$		⊖	⊖

Abbinamenti standard

Alcuni abbinamenti ibridi albero/flangia sono eseguibili anche per riduttori VF di interasse 130 e superiore. In questo caso consultare il Servizio Tecnico di Bonfiglioli per la disponibilità.

Le configurazioni risultanti dalla tabella sopra riportata sono da intendersi possibili esclusivamente per quanto riguarda la compatibilità geometrica.

La compatibilità meccanica dell'insieme motore/riduttore dovrà essere ulteriormente verificata mediante l'uso delle consuete tabelle di selezione per potenza/velocità.

In particolare dovranno essere evitati gli abbinamenti motore che generano fattori di sicurezza  $S < 0,9$ .





## 25 MOMENTO D'INERZIA

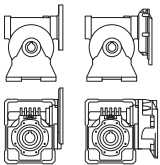
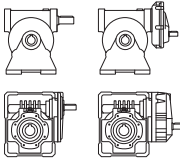

Le tabelle tecniche seguenti indicano i valori del momento d'inerzia  $J_r$  [Kgm<sup>2</sup>] riferiti all'asse veloce del riduttore; per una migliore facilità di lettura riportiamo le definizioni dei simboli usati:

	<p>I valori riferiti a questo simbolo sono da attribuire al riduttore compatto senza motore. In questo caso, per avere il momento d'inerzia complessivo del motoriduttore, si dovrà sommare il valore corrispondente al riduttore compatto, a quello del motore da applicare (dato reperibile nelle tabelle delle caratteristiche tecniche dei motori elettrici).</p>		<p>I valori relativi a questi simboli sono da attribuire al riduttore predisposto per attacco motore (grandezza IEC...).</p>
			<p>I valori attribuiti al riduttore sono riferiti a questi simboli.</p>

### VF 27



		i	J ( $\cdot 10^{-4}$ ) [kgm <sup>2</sup> ]				
			P27				
<b>VF 27</b>	VF 27_7	7	0.02	—	—	—	0.02
	VF 27_10	10	0.01	—	—	—	0.01
	VF 27_15	15	0.01	—	—	—	0.01
	VF 27_20	20	0.01	—	—	—	0.01
	VF 27_30	30	0.01	—	—	—	0.01
	VF 27_40	40	0.01	—	—	—	0.01
	VF 27_60	60	0.01	—	—	—	0.01
	VF 27_70	70	0.01	—	—	—	0.01

### VF 30

		i	J ( $\cdot 10^{-4}$ ) [kgm <sup>2</sup> ]				
			P56	P63			
<b>VF 30</b>	VF 30_7	7	0.08	0.07	—	—	0.04
	VF 30_10	10	0.07	0.06	—	—	0.03
	VF 30_15	15	0.07	0.06	—	—	0.03
	VF 30_20	20	0.06	0.06	—	—	0.03
	VF 30_30	30	0.06	0.06	—	—	0.03
	VF 30_40	40	0.06	0.06	—	—	0.03
	VF 30_60	60	0.06	0.05	—	—	0.02
	VF 30_70	70	0.06	—	—	—	0.02



## VF 44 - VFR 44

		i	J ( $\cdot 10^{-4}$ ) [kgm <sup>2</sup> ]					
			 S44	P63	P71	 HS		
<b>VF 44</b>	VF 44_7	7	—	0.29	0.27	—	—	0.18
	VF 44_10	10	—	0.24	0.22	—	—	0.14
	VF 44_14	14	—	0.23	0.21	—	—	0.12
	VF 44_20	20	—	0.19	0.18	—	—	0.09
	VF 44_28	28	—	0.21	0.19	—	—	0.11
	VF 44_35	35	—	0.19	0.18	—	—	0.09
	VF 44_46	46	—	0.18	—	—	—	0.08
	VF 44_60	60	—	0.17	—	—	—	0.07
	VF 44_70	70	—	0.17	—	—	—	0.07
	VF 44_100	100	—	0.17	—	—	—	0.07
<b>VFR 44</b>	VFR 44_70	70	0.21	—	—	—	—	—
	VFR 44_100	100	0.20	—	—	—	—	—
	VFR 44_140	140	0.20	—	—	—	—	—
	VFR 44_175	175	0.20	—	—	—	—	—
	VFR 44_230	230	0.20	—	—	—	—	—
	VFR 44_300	300	0.20	—	—	—	—	—
	VFR 44_350	350	0.20	—	—	—	—	—
	VFR 44_500	500	0.20	—	—	—	—	—

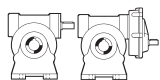

## VF 49 - VFR 49

		i	J ( $\cdot 10^{-4}$ ) [kgm <sup>2</sup> ]					
			P63	P71	 P80		 HS	
<b>VF 49</b>	VF 49_7	7	0.69	0.67	0.61	—	—	0.42
	VF 49_10	10	0.61	0.60	0.53	—	—	0.34
	VF 49_14	14	0.58	0.57	0.5	—	—	0.31
	VF 49_18	18	0.54	0.53	0.46	—	—	0.27
	VF 49_24	24	0.52	0.5	0.44	—	—	0.24
	VF 49_28	28	0.56	0.54	0.48	—	—	0.28
	VF 49_36	36	0.53	0.51	—	—	—	0.25
	VF 49_45	45	0.51	0.49	—	—	—	0.24
	VF 49_60	60	0.50	0.48	—	—	—	0.23
	VF 49_70	70	0.50	—	—	—	—	0.22
	VF 49_80	80	0.49	—	—	—	—	0.22
	VF 49_100	100	0.49	—	—	—	—	0.22
<b>VFR 49</b>	VFR 49_30	30	0.74	—	—	—	—	0.94
	VFR 49_42	42	0.73	—	—	—	—	0.93
	VFR 49_54	54	0.73	—	—	—	—	0.93
	VFR 49_72	72	0.73	—	—	—	—	0.93
	VFR 49_84	84	0.73	—	—	—	—	0.93
	VFR 49_108	108	0.73	—	—	—	—	0.93
	VFR 49_135	135	0.73	—	—	—	—	0.93
	VFR 49_180	180	0.73	—	—	—	—	0.93
	VFR 49_210	210	0.72	—	—	—	—	0.92
	VFR 49_240	240	0.72	—	—	—	—	0.92
	VFR 49_300	300	0.72	—	—	—	—	0.92



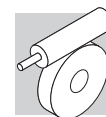

## W 63 - WR 63

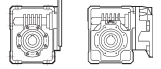
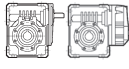
		i	J ( $\cdot 10^{-4}$ ) [kgm <sup>2</sup> ]									
												
			S1	S2	S3	P63	P71	P80	P90			HS
<b>W 63</b>	W 63_7	7	3.4	3.6	—	—	3.5	3.5	3.5	—	—	3.6
	W 63_10	10	3.1	3.3	—	—	3.2	3.3	3.2	—	—	3.3
	W 63_12	12	3.1	3.3	—	—	3.1	3.2	3.1	—	—	3.3
	W 63_15	15	3.0	3.2	—	—	3.0	3.1	3.0	—	—	3.2
	W 63_19	19	2.9	3.1	—	—	2.9	3.0	2.9	—	—	3.1
	W 63_24	24	2.8	3.1	—	—	2.9	3.0	2.9	—	—	3.0
	W 63_30	30	2.9	3.1	—	—	2.9	3.0	2.9	—	—	3.1
	W 63_38	38	2.8	3.1	—	—	2.9	3.0	2.9	—	—	3.0
	W 63_45	45	2.8	3.0	—	—	2.9	2.9	2.9	—	—	3.0
	W 63_64	64	2.8	3.0	—	—	2.8	2.9	2.8	—	—	3.0
	W 63_80	80	2.8	3.0	—	—	2.8	2.9	2.8	—	—	3.0
W 63_100	100	2.8	3.0	—	—	2.8	2.9	2.8	—	—	2.9	
<b>WR 63</b>	WR 63_21	21	—	—	—	0.84	0.83	—	—	—	—	0.81
	WR 63_30	30	—	—	—	0.81	0.80	—	—	—	—	0.78
	WR 63_36	36	—	—	—	0.81	0.80	—	—	—	—	0.77
	WR 63_45	45	—	—	—	0.80	0.79	—	—	—	—	0.76
	WR 63_57	57	—	—	—	0.79	0.78	—	—	—	—	0.75
	WR 63_72	72	—	—	—	0.78	0.77	—	—	—	—	0.74
	WR 63_90	90	—	—	—	0.79	0.78	—	—	—	—	0.75
	WR 63_114	114	—	—	—	0.78	0.77	—	—	—	—	0.74
	WR 63_135	135	—	—	—	0.78	0.77	—	—	—	—	0.74
	WR 63_192	192	—	—	—	0.77	0.76	—	—	—	—	0.74
	WR 63_240	240	—	—	—	0.77	0.76	—	—	—	—	0.74
WR 63_300	300	—	—	—	0.77	0.76	—	—	—	—	0.73	



## W 75 - WR 75

		i	J ( $\cdot 10^{-4}$ ) [kgm <sup>2</sup> ]									
			S1	S2	S3	P63	P71	P80	P90	P100	P112	HS
<b>W 75</b>	W 75_7	7	6.9	6.6	6.6	—	6.9	7.0	6.9	6.9	6.9	7.3
	W 75_10	10	6.4	6.1	6.1	—	6.4	6.4	6.3	5.7	5.7	6.8
	W 75_15	15	6.1	5.8	5.8	—	6.1	6.1	6.0	5.3	5.3	6.5
	W 75_20	20	5.9	5.6	5.6	—	5.9	5.9	5.9	5.2	5.2	6.3
	W 75_25	25	5.9	5.6	5.6	—	6.0	6.0	5.9	5.2	5.2	6.3
	W 75_30	30	5.9	5.6	5.6	—	5.9	5.9	5.9	5.2	5.2	6.3
	W 75_40	40	5.9	5.6	5.6	—	5.9	5.9	5.8	5.2	5.2	6.3
	W 75_50	50	5.9	5.6	5.6	—	5.9	5.9	5.8	5.1	5.1	6.2
	W 75_60	60	5.8	5.5	5.5	—	5.8	5.9	5.8	5.1	5.1	6.2
	W 75_80	80	5.8	5.5	5.5	—	5.8	5.8	5.8	5.1	5.1	6.2
W 75_100	100	5.8	5.5	5.5	—	5.8	5.8	5.7	5.0	5.0	6.2	

<b>WR 75</b>	WR 75_21	21	—	—	—	1.2	1.2	2.1	—	—	—	1.9
	WR 75_30	30	—	—	—	1.1	1.1	2.1	—	—	—	1.1
	WR 75_45	45	—	—	—	1.1	1.1	2.0	—	—	—	1.1
	WR 75_60	60	—	—	—	1.1	1.1	2.0	—	—	—	1.0
	WR 75_75	75	—	—	—	1.1	1.1	2.0	—	—	—	1.0
	WR 75_90	90	—	—	—	1.1	1.1	2.0	—	—	—	1.0
	WR 75_120	120	—	—	—	1.1	1.1	2.0	—	—	—	1.0
	WR 75_150	150	—	—	—	1.1	1.1	2.0	—	—	—	1.0
	WR 75_180	180	—	—	—	1.1	1.1	2.0	—	—	—	1.0
	WR 75_240	240	—	—	—	1.1	1.1	2.0	—	—	—	1.0
	WR 75_300	300	—	—	—	1.1	1.1	2.0	—	—	—	1.0

		J ( $\cdot 10^{-4}$ ) [kgm <sup>2</sup> ]
i		 <b>P90</b>

<b>WR 75_P90 B5</b>	WR 75_15	15	6.0
	WR 75_22.5	22.5	5.9
	WR 75_30	30	5.8
	WR 75_37.5	37.5	5.8
	WR 75_45	45	5.8
	WR 75_60	60	5.8
	WR 75_75	75	5.8
	WR 75_90	90	5.7
	WR 75_120	120	5.7
	WR 75_150	150	5.7

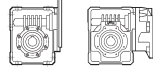
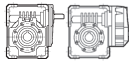

## W 86 - WR 86

		i	J ( $\cdot 10^{-4}$ ) [kgm <sup>2</sup> ]									
												
			S1	S2	S3	P63	P71	P80	P90	P100	HS	
<b>W 86</b>	W 86_7	7	9.7	9.4	9.4	—	9.7	9.7	9.6	9.6	—	10.1
	W 86_10	10	8.4	8.1	8.1	—	8.4	8.4	8.3	7.7	—	8.9
	W 86_15	15	7.7	7.4	7.4	—	7.7	7.7	7.7	7.0	—	8.2
	W 86_20	20	6.9	6.6	6.6	—	6.9	7.0	6.9	6.2	—	7.4
	W 86_23	23	6.8	6.5	6.5	—	6.8	6.9	6.8	6.1	—	7.3
	W 86_30	30	7.3	7.0	7.0	—	7.3	7.3	7.3	6.6	—	7.8
	W 86_40	40	6.7	6.4	6.4	—	6.7	6.7	6.6	6.0	—	7.2
	W 86_46	46	6.7	6.4	6.4	—	6.7	6.7	6.6	5.9	—	7.1
	W 86_56	56	6.6	6.3	6.3	—	6.6	6.7	6.6	5.9	—	7.1
	W 86_64	64	6.6	6.3	6.3	—	6.6	6.6	6.5	5.9	—	7.1
	W 86_80	80	6.6	6.3	6.3	—	6.6	6.6	6.5	5.9	—	7.1
W 86_100	100	6.4	6.1	6.1	—	6.4	6.5	6.4	5.7	—	6.9	

<b>WR 86</b>	WR 86_21	21	—	—	—	1.5	1.5	2.4	—	—	—	2.2
	WR 86_30	30	—	—	—	1.4	1.3	2.3	—	—	—	1.3
	WR 86_45	45	—	—	—	1.3	1.3	2.2	—	—	—	1.2
	WR 86_60	60	—	—	—	1.2	1.2	2.1	—	—	—	1.2
	WR 86_69	69	—	—	—	1.2	1.2	2.1	—	—	—	1.1
	WR 86_90	90	—	—	—	1.2	1.2	2.2	—	—	—	1.2
	WR 86_120	120	—	—	—	1.2	1.2	2.1	—	—	—	1.1
	WR 86_138	138	—	—	—	1.2	1.2	2.1	—	—	—	1.1
	WR 86_168	168	—	—	—	1.2	1.2	2.1	—	—	—	1.1
	WR 86_192	192	—	—	—	1.2	1.1	2.1	—	—	—	1.1
	WR 86_240	240	—	—	—	1.2	1.1	2.1	—	—	—	1.1
WR 86_300	300	—	—	—	1.1	1.1	2.1	—	—	—	1.1	

		J ( $\cdot 10^{-4}$ ) [kgm <sup>2</sup> ]	
		i	 P90

<b>WR 86_P90 B5</b>	WR 86_15	15	6.9
	WR 86_22.5	22.5	6.6
	WR 86_30	30	6.3
	WR 86_34.5	34.5	6.2
	WR 86_45	45	6.4
	WR 86_60	60	6.2
	WR 86_69	69	6.1
	WR 86_84	84	6.1
	WR 86_96	96	6.0
	WR 86_120	120	6.0
	WR 86_150	150	5.9



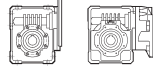
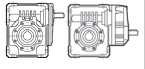

## W 110 - WR 110

		i	J ( $\cdot 10^{-4}$ ) [kgm <sup>2</sup> ]									
			 S1   S2   S3			 P63   P71   P80   P90   P100   P132					 HS	
<b>W 110</b>	W 110_7	7	—	22	22	—	—	23	23	23	28	23
	W 110_10	10	—	19	19	—	—	19	19	24	24	20
	W 110_15	15	—	17	17	—	—	17	17	22	22	17
	W 110_20	20	—	14	14	—	—	14	14	19	19	15
	W 110_23	23	—	14	14	—	—	14	14	19	19	15
	W 110_30	30	—	15	15	—	—	16	16	20	20	16
	W 110_40	40	—	13	13	—	—	14	14	19	19	14
	W 110_46	46	—	13	13	—	—	13	13	18	18	14
	W 110_56	56	—	13	13	—	—	13	13	18	18	14
	W 110_64	64	—	13	13	—	—	13	13	18	18	14
	W 110_80	80	—	13	13	—	—	13	13	18	18	14
W 110_100	100	—	13	13	—	—	13	13	18	18	14	
<b>WR 110</b>	WR 110_21	21	—	—	—	—	3.0	9.0	8.8	8.9	—	9.2
	WR 110_30	30	—	—	—	—	2.5	8.6	8.4	8.4	—	8.8
	WR 110_45	45	—	—	—	—	2.3	8.3	8.2	8.2	—	8.5
	WR 110_60	60	—	—	—	—	2.0	8.1	7.9	7.9	—	8.3
	WR 110_69	69	—	—	—	—	2.0	8.0	7.9	7.9	—	8.2
	WR 110_90	90	—	—	—	—	2.2	8.2	8.1	8.1	—	8.4
	WR 110_120	120	—	—	—	—	1.9	8.0	7.8	7.9	—	8.2
	WR 110_138	138	—	—	—	—	1.9	8.0	7.8	7.8	—	8.2
	WR 110_168	168	—	—	—	—	1.9	8.0	7.8	7.8	—	8.1
	WR 110_192	192	—	—	—	—	1.9	7.9	7.8	7.8	—	8.1
	WR 110_240	240	—	—	—	—	1.9	7.9	7.8	7.8	—	8.1
WR 110_300	300	—	—	—	—	1.9	7.9	7.8	7.8	—	8.1	





## VF 130 - VFR 130

		i	J ( $\cdot 10^{-4}$ ) [kgm <sup>2</sup> ]					HS
			P80	P90	 P100	 P112	P132	
<b>VF 130</b>	VF 130_7	7	—	—	36	36	35	31
	VF 130_10	10	—	—	27	27	25	22
	VF 130_15	15	—	—	20	20	18	15
	VF 130_20	20	—	—	17	17	15	11
	VF 130_23	23	—	—	16	16	14	11
	VF 130_30	30	—	—	17	17	15	12
	VF 130_40	40	—	—	15	15	14	9.9
	VF 130_46	46	—	14	14	14	—	8.2
	VF 130_56	56	—	13	13	13	—	7.8
	VF 130_64	64	—	13	13	13	—	7.4
	VF 130_80	80	—	13	12	12	—	7.0
	VF 130_100	100	—	13	—	—	—	8.9
<b>VFR 130</b>	VFR 130_30	30	5.3	5.3	5.2	5.2	—	5.7
	VFR 130_45	45	4.5	4.5	4.4	4.4	—	4.9
	VFR 130_60	60	4.2	4.1	4.1	4.1	—	4.6
	VFR 130_69	69	4.1	4.0	4.0	4.0	—	4.5
	VFR 130_90	90	4.2	4.1	4.1	4.1	—	4.6
	VFR 130_120	120	4.0	3.9	4.0	4.0	—	4.4
	VFR 130_138	138	3.8	3.8	3.7	3.7	—	4.2
	VFR 130_168	168	3.8	3.7	3.7	3.7	—	4.1
	VFR 130_192	192	3.7	3.7	3.6	3.6	—	4.1
	VFR 130_240	240	3.7	3.6	3.6	3.6	—	4.1
	VFR 130_300	300	3.9	3.8	3.8	3.8	—	4.3



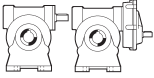

## VF 150 - VFR 150

		i	J ( $\cdot 10^{-4}$ ) [kgm <sup>2</sup> ]				
			P90	 P100	 P112	P132	 HS
<b>VF 150</b>	VF 150_7	7	—	—	—	58	50
	VF 150_10	10	—	—	—	44	35
	VF 150_15	15	—	—	—	29	21
	VF 150_20	20	—	—	—	27	19
	VF 150_23	23	—	28	28	26	17
	VF 150_30	30	—	31	31	29	21
	VF 150_40	40	—	26	26	24	16
	VF 150_46	46	—	24	24	22	13
	VF 150_56	56	25	24	24	—	13
	VF 150_64	64	24	23	23	—	12
	VF 150_80	80	23	22	22	—	11
	VF 150_100	100	23	22	22	—	11
<b>VFR 150</b>	VFR 150_25	25	—	—	—	15	—
	VFR 150_30	30	10	10	10	—	11
	VFR 150_37.5	37.5	—	—	—	13	—
	VFR 150_45	45	8.8	8.8	8.8	—	9.7
	VFR 150_50	50	—	—	—	12	—
	VFR 150_60	60	8.3	8.3	8.3	—	9.2
	VFR 150_69	69	8.4	8.4	8.4	—	9.3
	VFR 150_90	90	8.7	8.7	8.7	—	9.7
	VFR 150_120	120	8.2	8.2	8.2	—	9.2
	VFR 150_138	138	7.9	7.9	7.9	—	8.9
	VFR 150_168	168	7.9	7.9	7.9	—	8.9
	VFR 150_192	192	7.8	7.8	7.8	—	8.8
	VFR 150_240	240	7.7	7.7	7.7	—	8.6
VFR 150_300	300	7.7	7.7	7.7	—	8.6	



## VF 185 - VFR 185

		i	J ( $\cdot 10^{-4}$ ) [kgm <sup>2</sup> ]						HS
			P90	P100	 P112	 P132	P160	P180	
<b>VF 185</b>	VF 185_7	7	—	—	—	—	—	146	128
	VF 185_10	10	—	—	—	—	—	108	91
	VF 185_15	15	—	—	—	—	70	88	50
	VF 185_20	20	—	—	—	—	69	66	48
	VF 185_30	30	—	—	—	58	54	—	34
	VF 185_40	40	—	—	—	63	61	—	41
	VF 185_50	50	—	59	59	58	—	—	35
	VF 185_60	60	—	55	55	53	—	—	31
	VF 185_80	80	—	52	52	51	—	—	28
	VF 185_100	100	—	51	51	—	—	—	27
<b>VFR 185</b>	VFR 185_25	25	—	—	—	24	—	—	—
	VFR 185_30	30	17	17	17	—	—	—	18
	VFR 185_37.5	37.5	—	—	—	17	—	—	—
	VFR 185_45	45	12	12	12	—	—	—	13
	VFR 185_50	50	—	—	—	17	—	—	—
	VFR 185_60	60	12	12	12	—	—	—	13
	VFR 185_75	75	—	—	—	15	—	—	—
	VFR 185_90	90	10	10	10	—	—	—	11
	VFR 185_100	100	—	—	—	16	—	—	—
	VFR 185_120	120	11	11	11	—	—	—	12
	VFR 185_150	150	10	10	10	—	—	—	11
	VFR 185_180	180	9.9	9.9	9.9	—	—	—	11
	VFR 185_240	240	9.6	9.6	9.6	—	—	—	11
VFR 185_300	300	9.5	9.4	9.4	—	—	—	10	



## VF 210 - VFR 210

		i	J ( $\cdot 10^{-4}$ ) [kgm <sup>2</sup> ]							
			P100	P112	P132	P160	P180	P200	P225	HS
<b>VF 210</b>	VF 210_7	7	—	—	286	286	286	286	286	286
	VF 210_10	10	—	—	177	177	177	177	177	177
	VF 210_15	15	—	—	120	120	120	120	120	120
	VF 210_20	20	—	—	116	116	116	116	116	116
	VF 210_30	30	—	—	81	81	81	81	81	81
	VF 210_40	40	—	—	98	98	98	98	98	98
	VF 210_50	50	—	—	84	84	84	84	84	84
	VF 210_60	60	—	—	75	75	75	75	75	75
	VF 210_80	80	—	—	68	68	68	68	68	68
	VF 210_100	100	—	—	63	63	63	63	63	63
<b>VFR 210</b>	VFR 210_30	30	48	48	47	47	—	—	—	51
	VFR 210_45	45	41	41	41	41	—	—	—	45
	VFR 210_60	60	41	41	41	40	—	—	—	45
	VFR 210_90	90	37	37	37	36	—	—	—	41
	VFR 210_120	120	39	39	39	38	—	—	—	43
	VFR 210_150	150	37	37	37	37	—	—	—	41
	VFR 210_180	180	36	36	36	36	—	—	—	40
	VFR 210_240	240	36	36	36	35	—	—	—	39
	VFR 210_300	300	35	35	35	34	—	—	—	39





## VF 250 - VFR 250

		i	J ( $\cdot 10^{-4}$ ) [kgm <sup>2</sup> ]							
			P100	P112	P132	P160	P180	P200	P225	HS
<b>VF 250</b>	VF 250_7	7	—	—	620	620	620	620	620	620
	VF 250_10	10	—	—	387	387	387	387	387	387
	VF 250_15	15	—	—	266	266	266	266	266	266
	VF 250_20	20	—	—	242	242	242	242	242	242
	VF 250_30	30	—	—	184	184	184	184	184	184
	VF 250_40	40	—	—	241	241	241	241	241	241
	VF 250_50	50	—	—	240	240	240	240	240	240
	VF 250_60	60	—	—	158	158	158	158	158	158
	VF 250_80	80	—	—	160	160	160	160	160	160
	VF 250_100	100	—	—	149	149	149	149	149	149
<b>VFR 250</b>	VFR 250_30	30	71	71	71	70	—	—	—	75
	VFR 250_45	45	58	58	57	57	—	—	—	61
	VFR 250_60	60	55	55	55	54	—	—	—	58
	VFR 250_90	90	48	48	48	48	—	—	—	52
	VFR 250_120	120	55	55	54	54	—	—	—	58
	VFR 250_150	150	55	55	54	54	—	—	—	58
	VFR 250_180	180	46	46	45	45	—	—	—	49
	VFR 250_240	240	46	46	45	45	—	—	—	49
	VFR 250_300	300	45	45	44	44	—	—	—	48

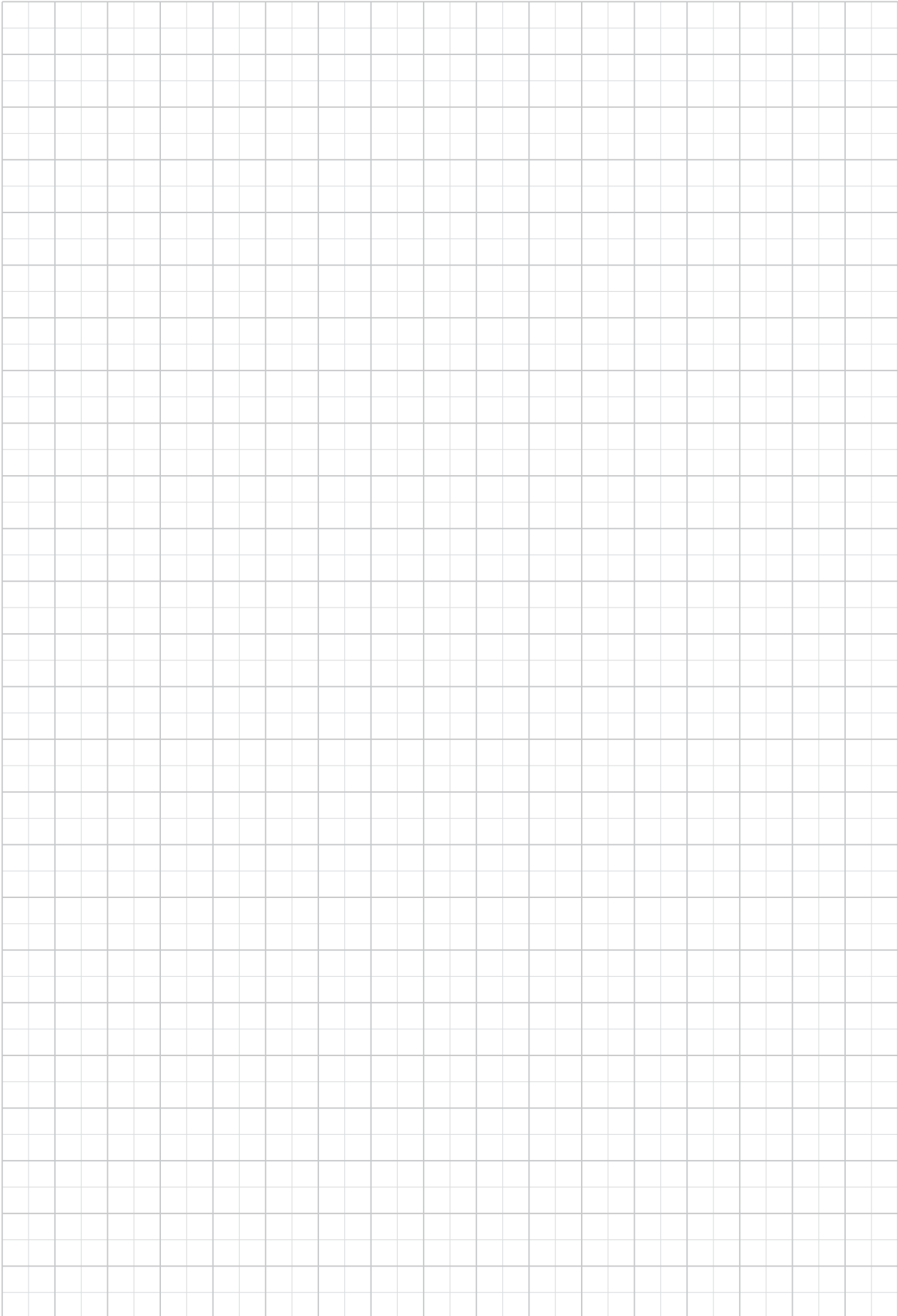



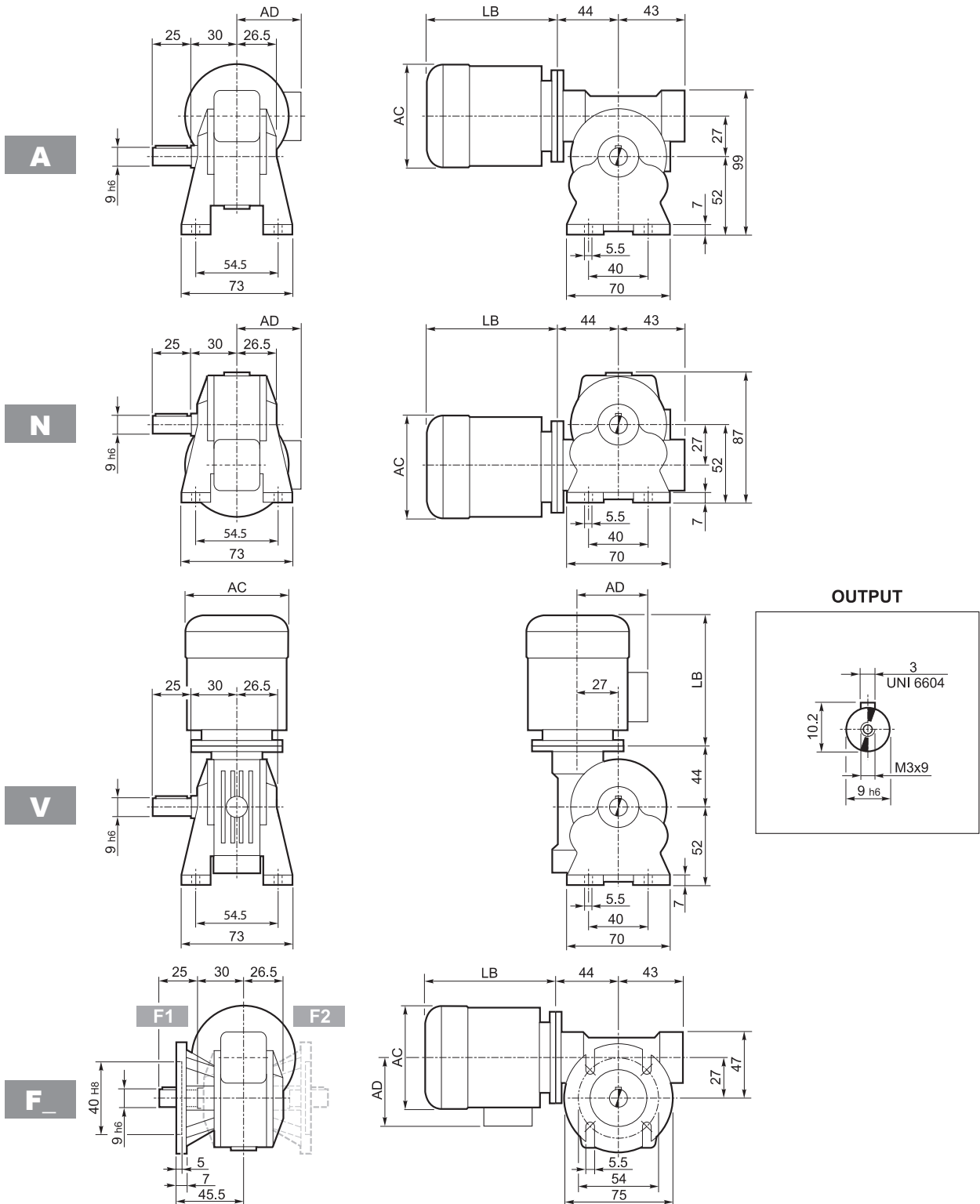

26 DIMENSIONI MOTORIDUTTORI E RIDUTTORI PREDISPOSTI IEC

VF 27...BN27



	P <sub>n</sub> kW	n min <sup>-1</sup>	M <sub>n</sub> Nm	η %	COSφ	I <sub>n</sub> A (400V)	I <sub>s</sub> I <sub>n</sub>	M <sub>s</sub> M <sub>n</sub>	M <sub>a</sub> M <sub>n</sub>	J <sub>m</sub> (·10 <sup>-4</sup> ) kgm <sup>2</sup>	 Kg	LB	AC	AD
<b>BN 27A 4</b>	0.04	1405	0.27	38.4	0.6	0.25	2.9	3.6	3.1	1.49	3.3	168	112	92
<b>BN 27B 4</b>	0.06	1340	0.43	46.8	0.65	0.28	2.6	2.3	2.0	1.49	3.3	168	112	92
<b>BN 27C 4</b>	0.09	1380	0.63	46	0.65	0.43	2.8	2.3	1.9	1.49	3.3	168	112	92



# VF 30...P (IEC)

**A**

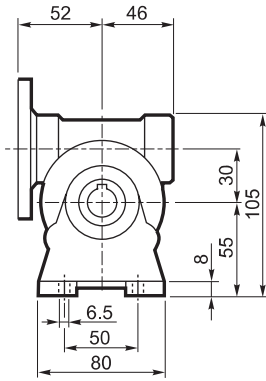
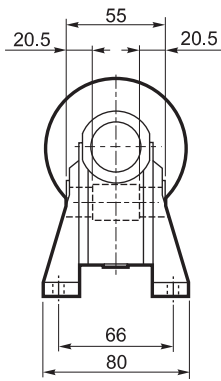

**N**

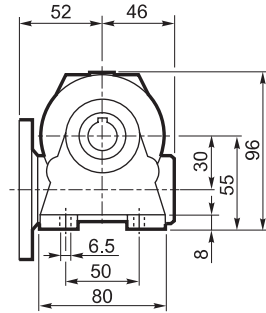
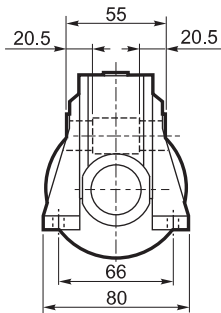

**V**

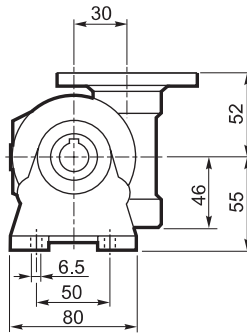
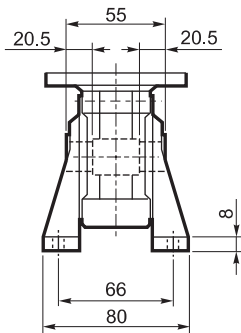

**P**

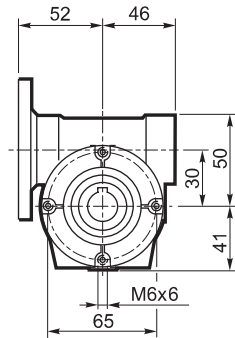
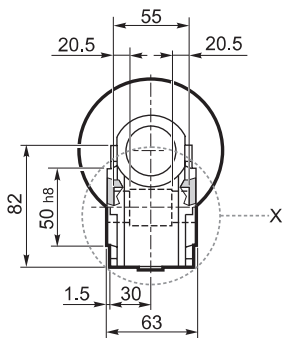

**INPUT**

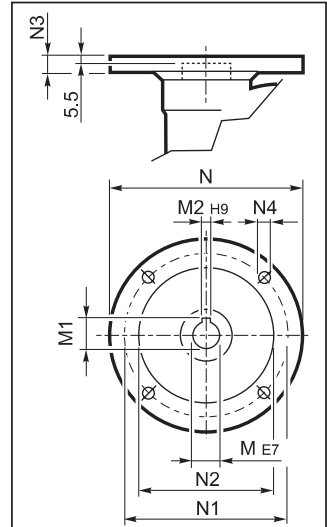

**P56 B14**

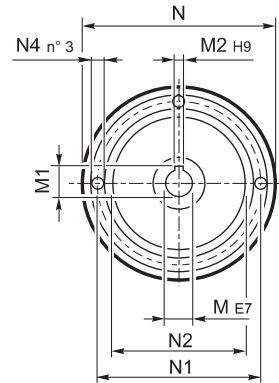

**OUTPUT**

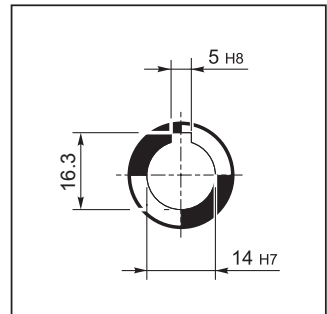

**X**

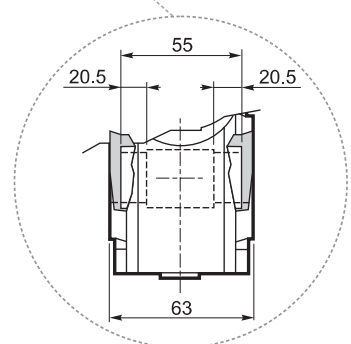



# VF 30...P (IEC)

**F**

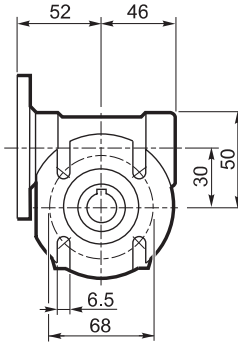
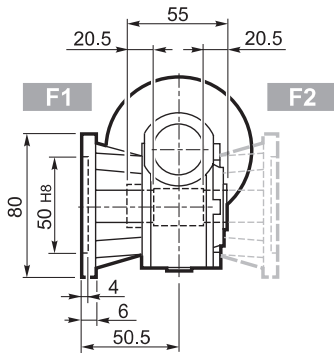

**U**

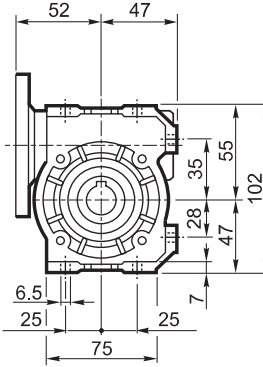
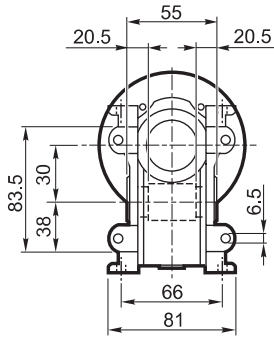

**INPUT**

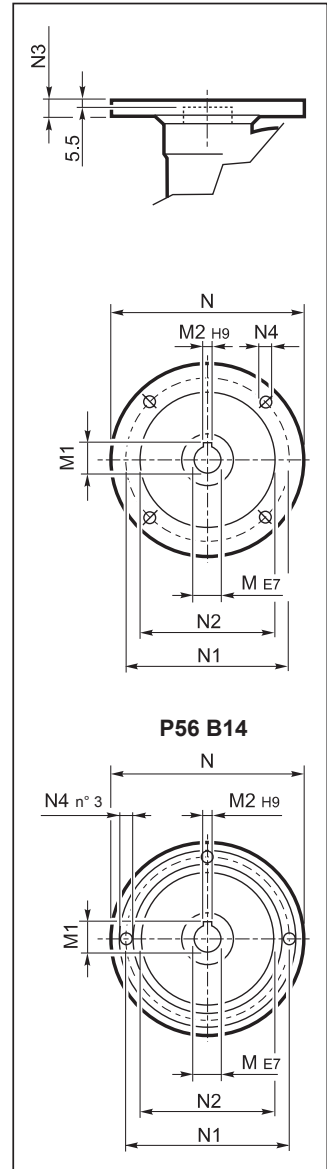

**OUTPUT**

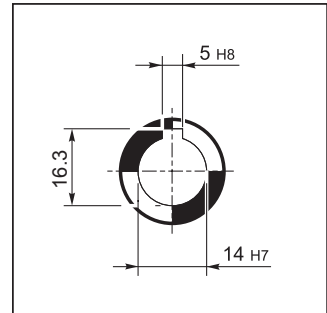

		M	M1	M2	N	N1	N2	N3	N4	
VF 30	P56 B5	9	10.4	3	120	100	80	7	7	1.1
VF 30	P56 B14	9	10.4	3	80	65	50	7	5.5	
VF 30	P63 B5	11	12.8	4	140	115	95	8	9.5	
VF 30	P63 B14	11	12.8	4	90	75	60	6	5.5	



# VF 44...P (IEC)

**A**

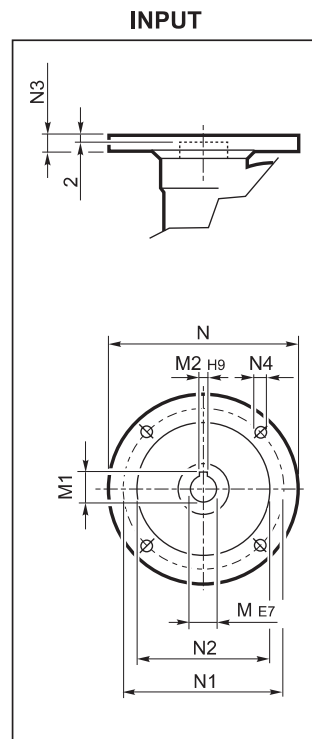
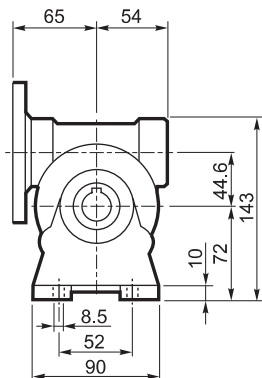
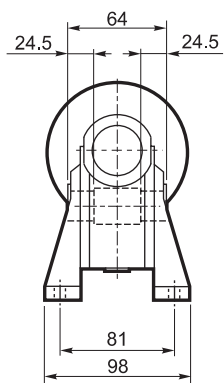

**N**

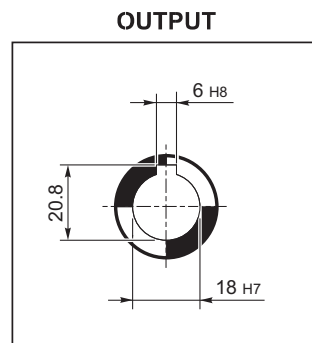
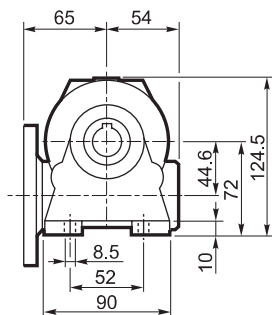
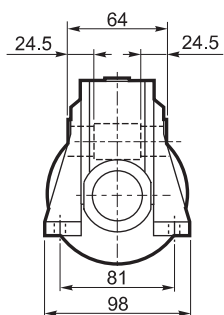

**V**

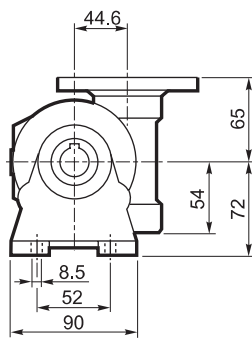
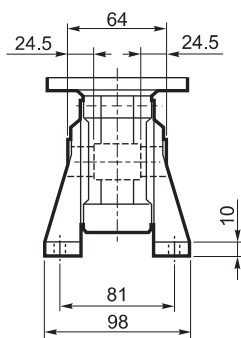

**P**

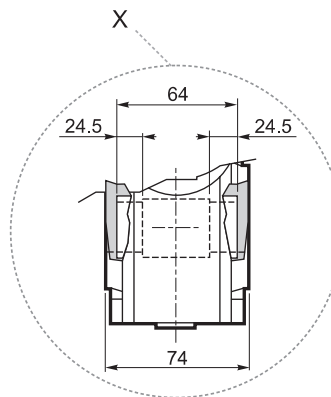
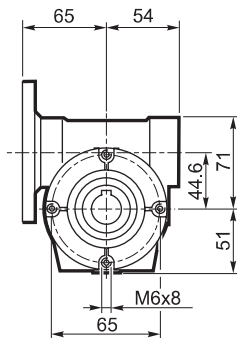
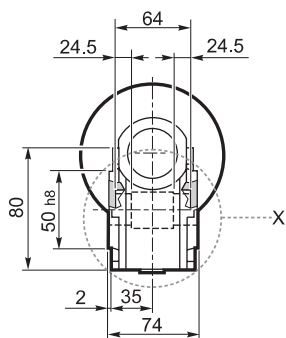



# VF 44...P (IEC)

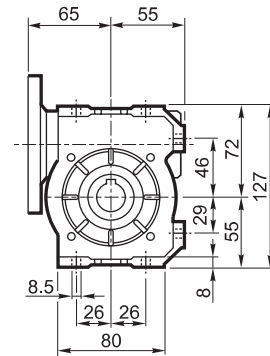
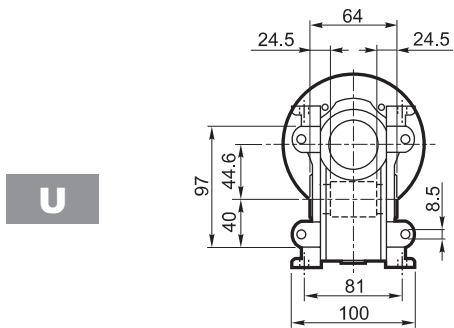
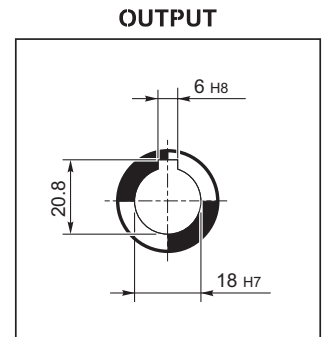
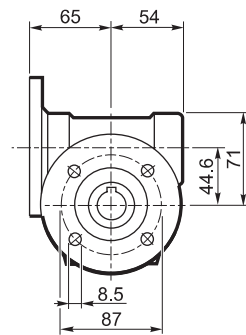
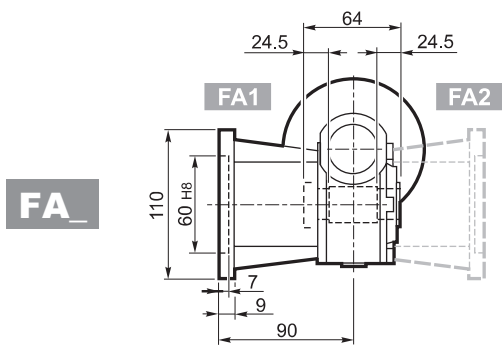
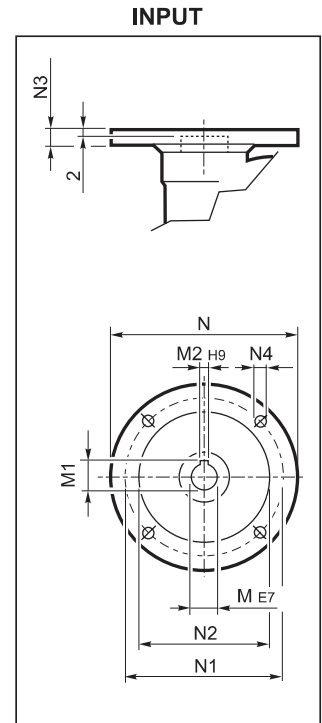
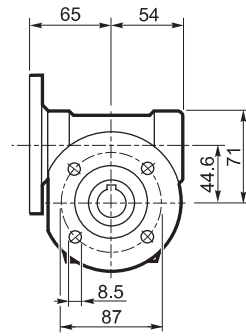
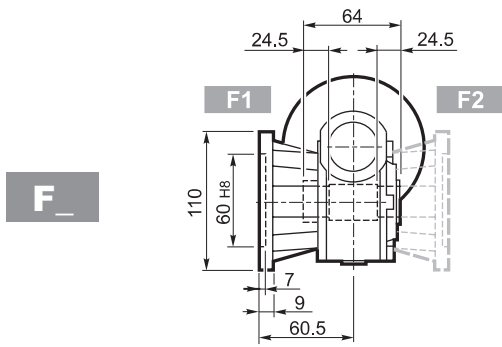

		M	M1	M2	N	N1	N2	N3	N4	
VF 44	P63 B5	11	12.8	4	140	115	95	10	9.5	2.0
VF 44	P71 B5	14	16.3	5	160	130	110	10	9.5	
VF 44	P63 B14	11	12.8	4	90	75	60	8	5.5	
VF 44	P71 B14	14	16.3	5	105	85	70	10	7	



# VFR 44...BN 44

**A**

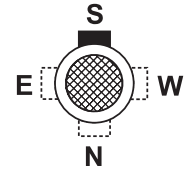
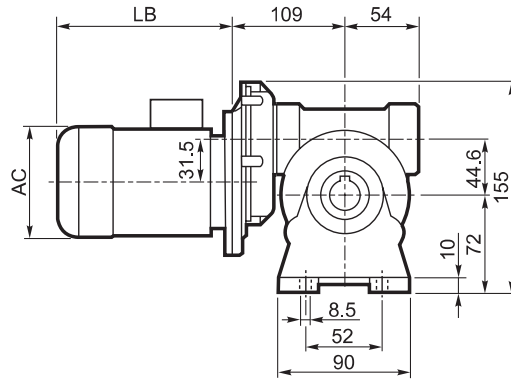
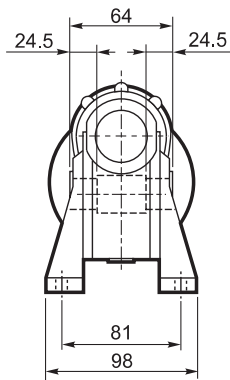

**OUTPUT**

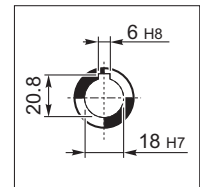

**N**

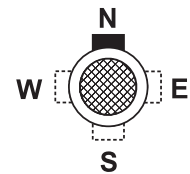
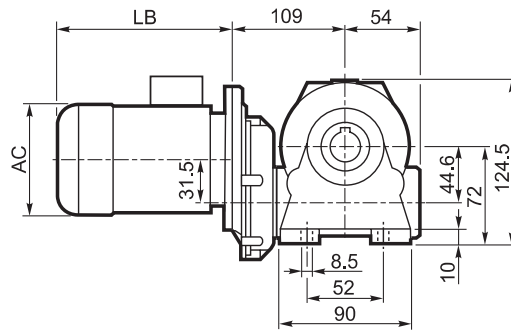
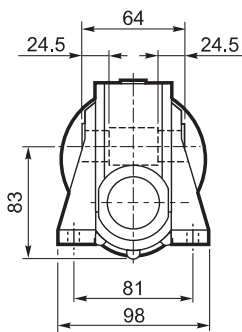

**V**

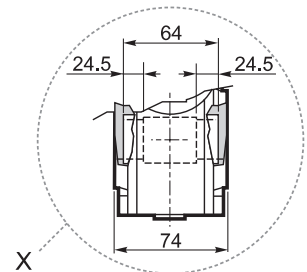
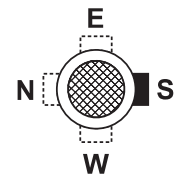
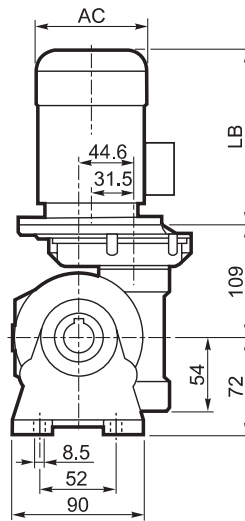
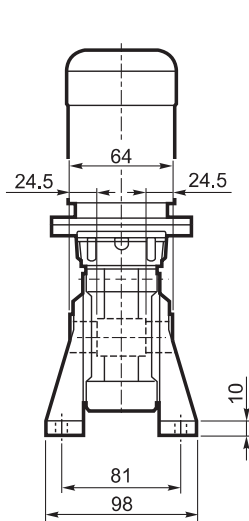

**P**

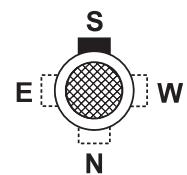
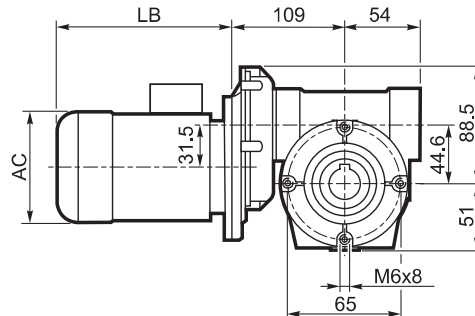
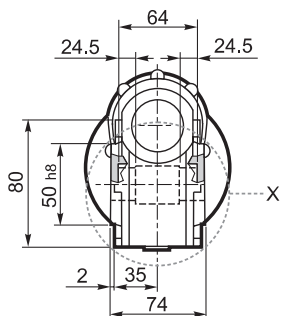





## VFR 44...BN 44

**F\_**

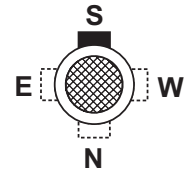
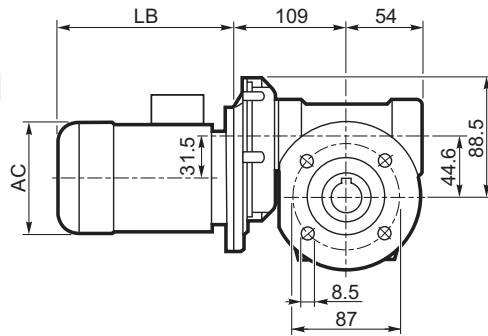
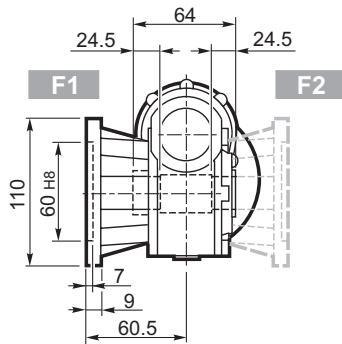

**OUTPUT**

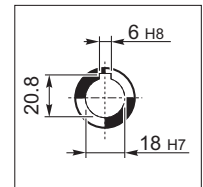

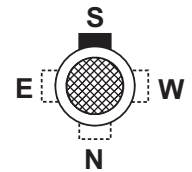
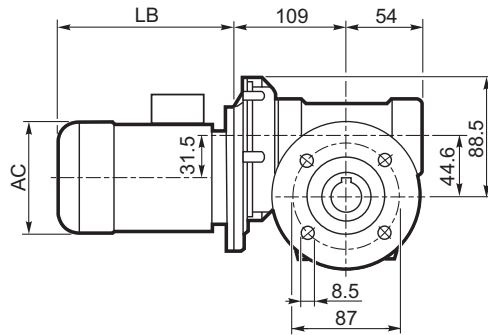
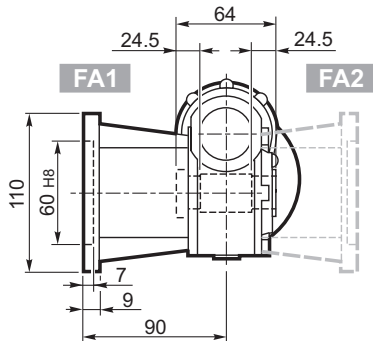

**FA\_**

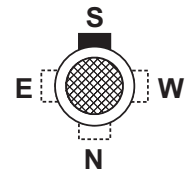
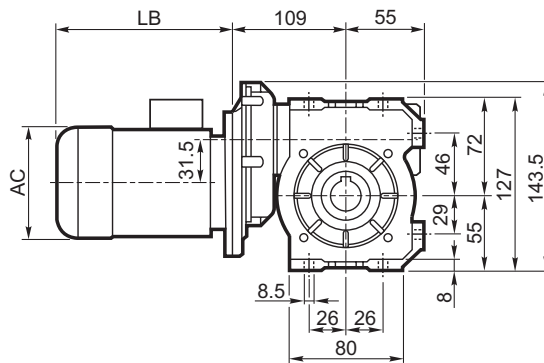
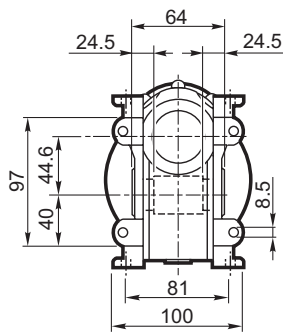

**U**



	$P_n$ kW	$n$ min <sup>-1</sup>	$M_n$ Nm	$\eta$ %	$\cos\phi$	$I_n$ A (400V)	$\frac{I_s}{I_n}$	$\frac{M_s}{M_n}$	$\frac{M_a}{M_n}$	$J_m$ ( $\cdot 10^{-4}$ ) kgm <sup>2</sup>		LB	AC	AD
<b>BN 44B4</b>	0.06	1380	0.42	40	0.58	0.38	2.4	2.3	1.9	1.22	4.7	168	112	94
<b>BN 44C4</b>	0.09	1380	0.63	46	0.65	0.43	2.8	2.3	2	1.49	4.6	168	112	94



# VF/VF 30/44...P (IEC)

**A**

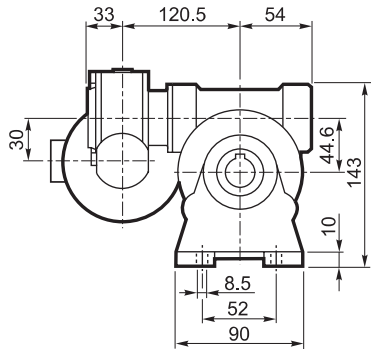

**N**

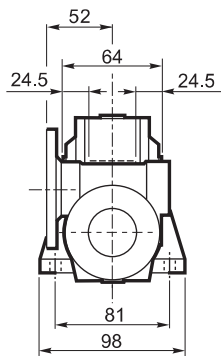

**V**

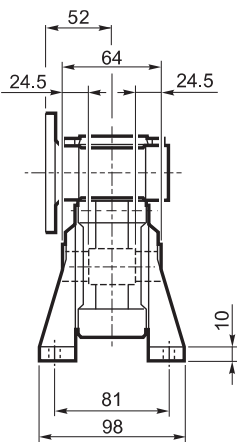

**P**

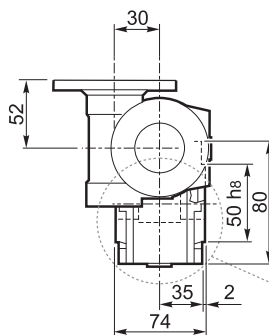
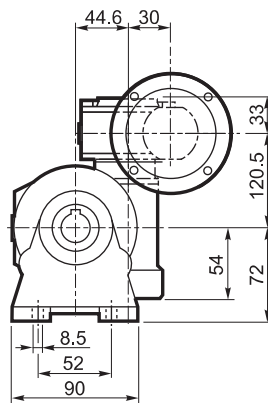
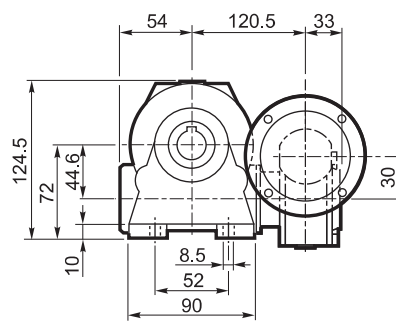
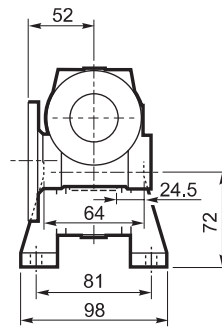
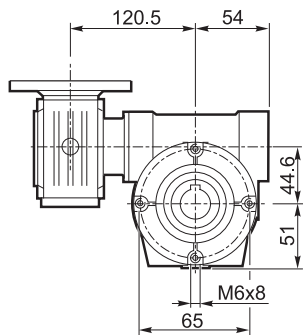

**INPUT**

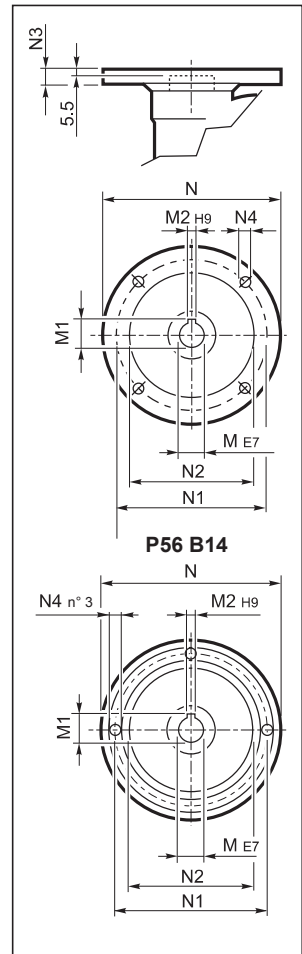

**OUTPUT**

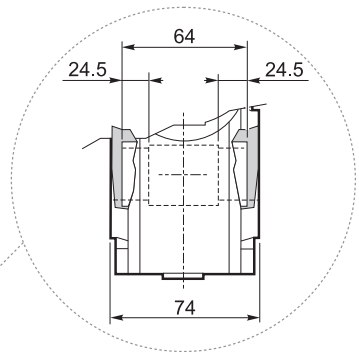
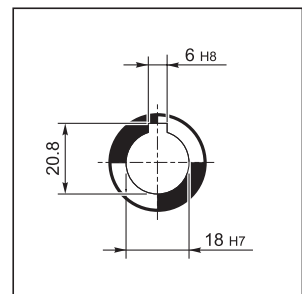



# VF/VF 30/44...P (IEC)

**F\_**

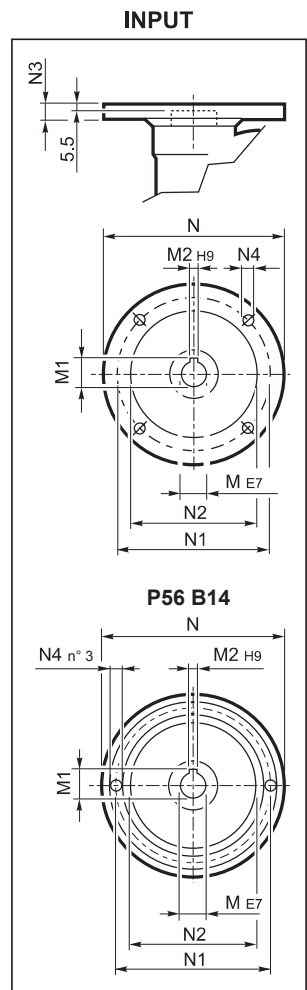
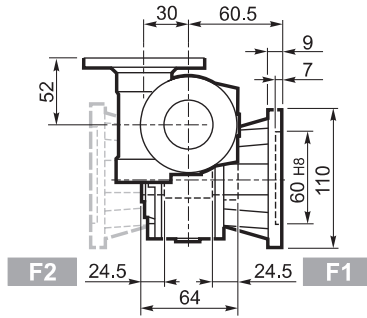
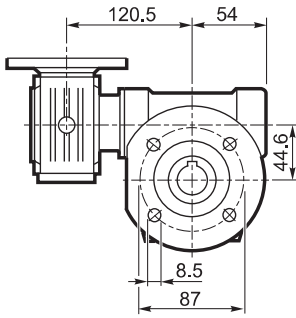

**FA\_**

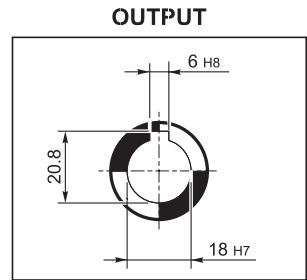
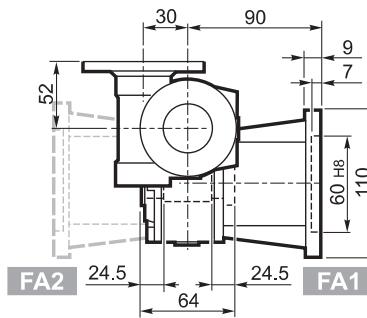
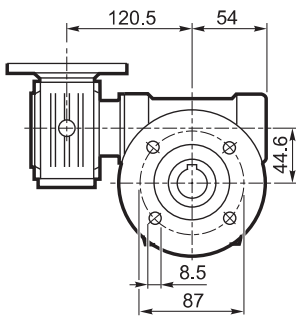

**U**

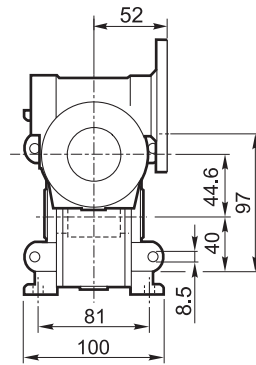
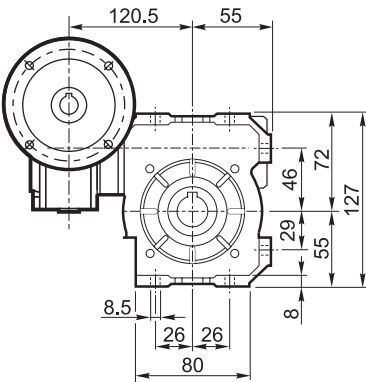

		M	M1	M2	N	N1	N2	N3	N4	
VF/VF 30/44	P56 B14	9	10.4	3	80	65	50	7	5.5	3.5
VF/VF 30/44	P63 B14	11	12.8	4	90	75	60	6	5.5	

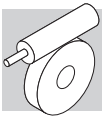

# VF 49...P (IEC)

**A**

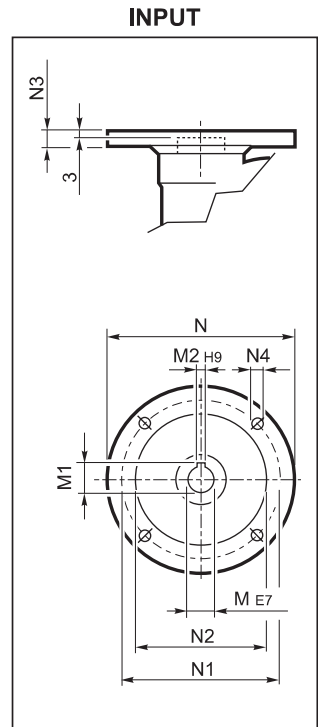
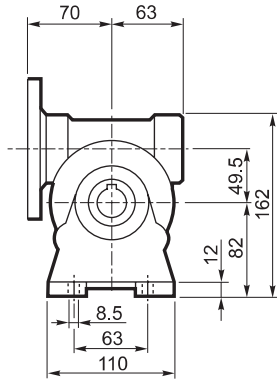
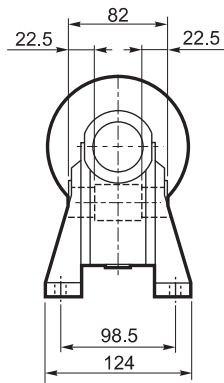

**N**

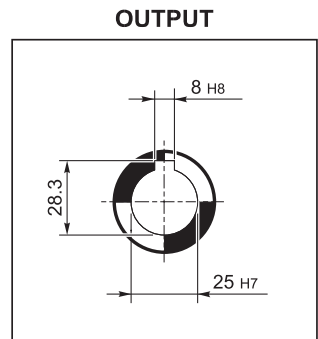
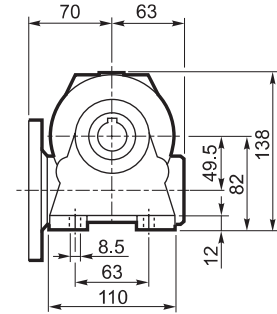
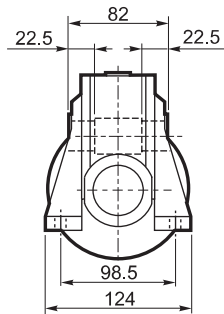

**V**

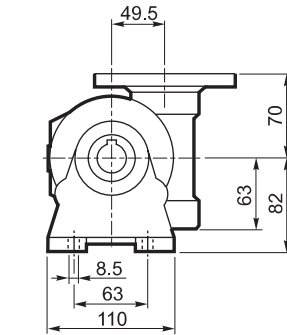
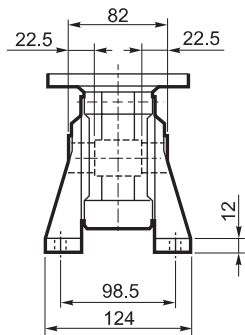

**P**

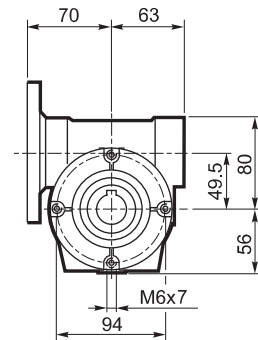
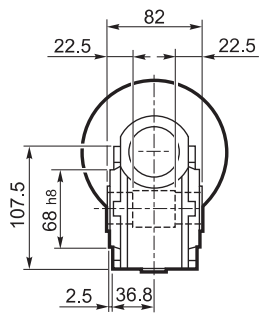



# VF 49...P (IEC)

**F\_**

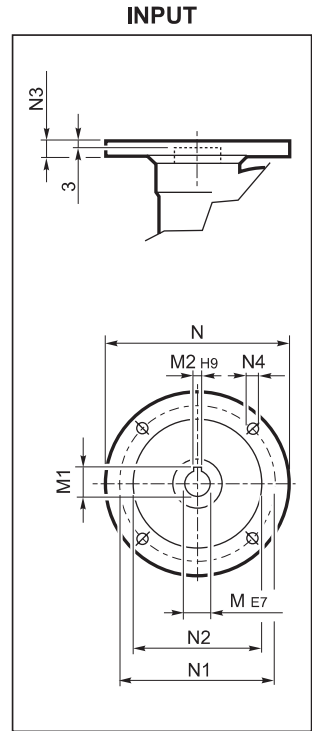
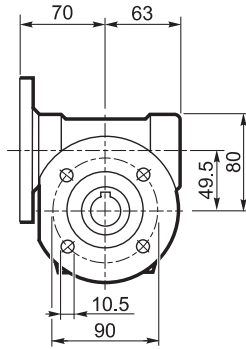
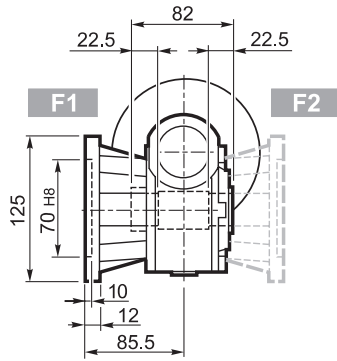

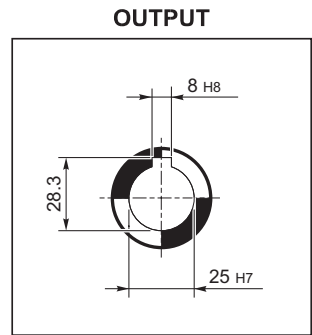
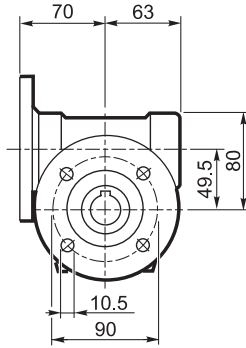
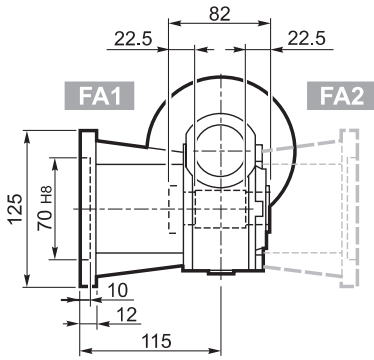

**FA\_**

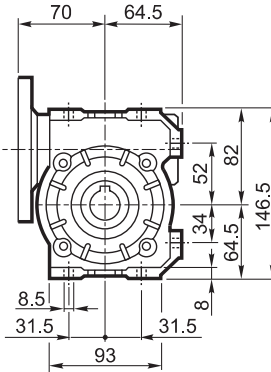
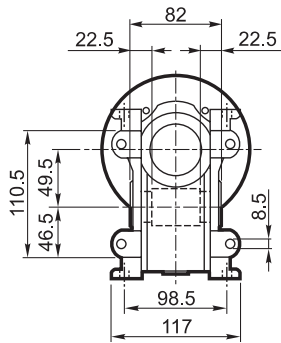

**U**



		M	M1	M2	N	N1	N2	N3	N4	
VF 49	P63 B5	11	12.8	4	140	115	95	10.5	9.5	3.0
VF 49	P71 B5	14	16.3	5	160	130	110	10.5	9.5	
VF 49	P80 B5	19	21.8	6	200	165	130	10	11.5	
VF 49	P63 B14	11	12.8	4	90	75	60	7	6	
VF 49	P71 B14	14	16.3	5	105	85	70	10.5	6.5	
VF 49	P80 B14	19	21.8	6	120	100	80	10	7	



# VFR 49...P (IEC)

**A**

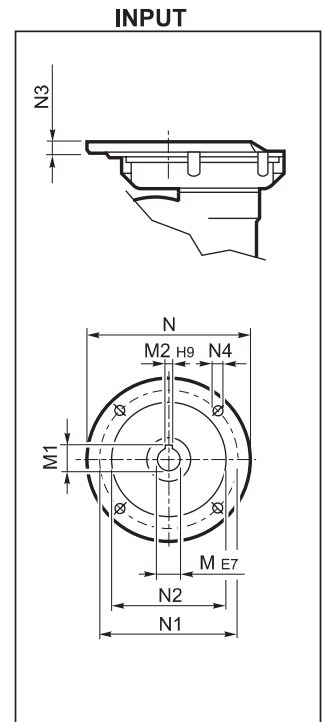
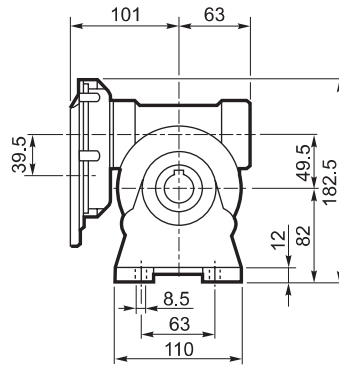
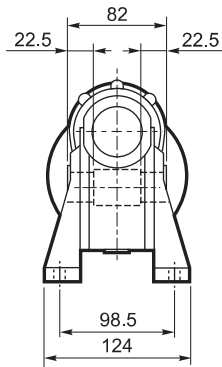

**N**

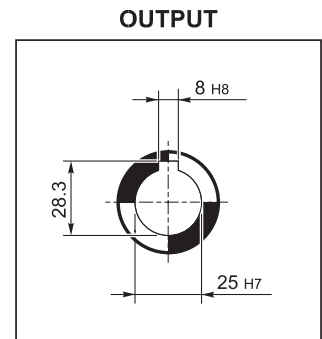
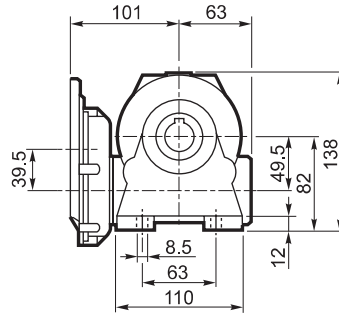
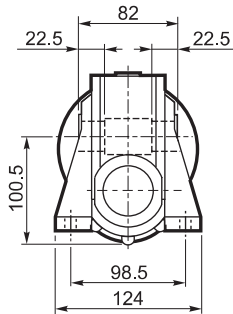

**V**

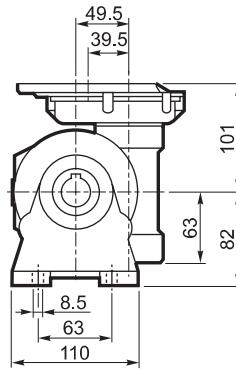
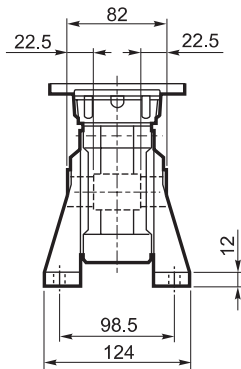

**P**

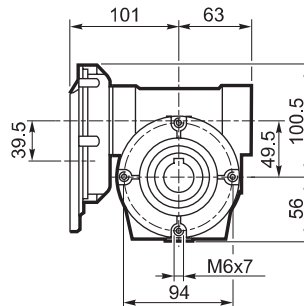
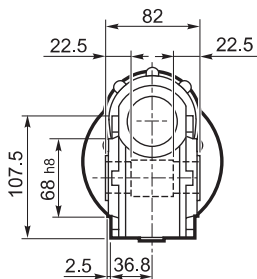



# VFR 49...P (IEC)

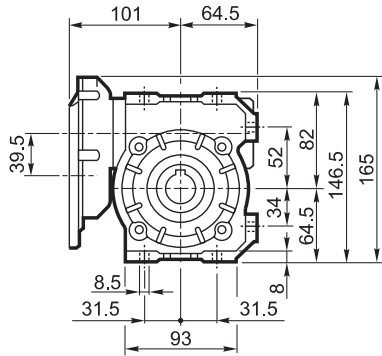
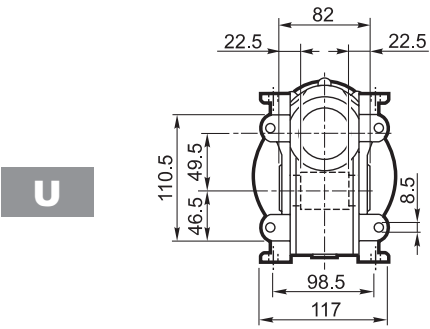
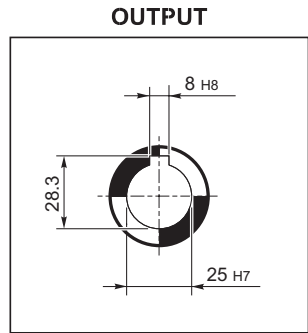
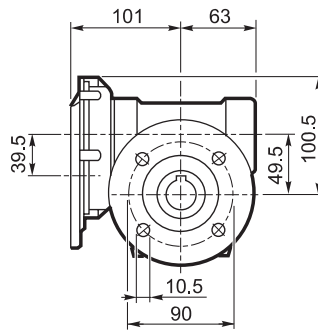
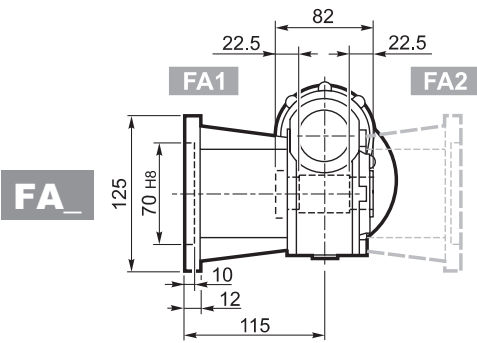
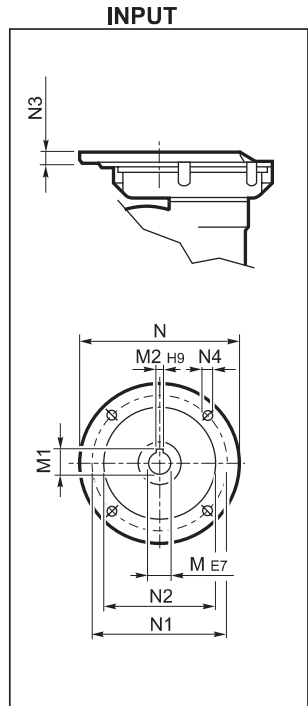
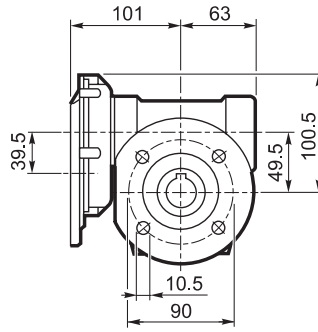
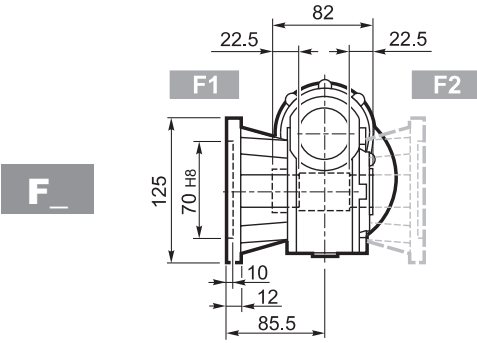

		<b>M</b>	<b>M1</b>	<b>M2</b>	<b>N</b>	<b>N1</b>	<b>N2</b>	<b>N3</b>	<b>N4</b>	
<b>VFR 49</b>	<b>P63 B5</b>	11	12.8	4	140	115	95	11	M8 x 19	5.0



# VF/VF 30/49...P (IEC)

**A**

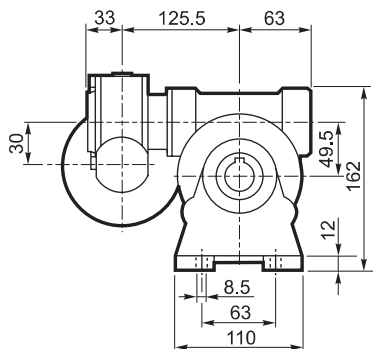

**N**

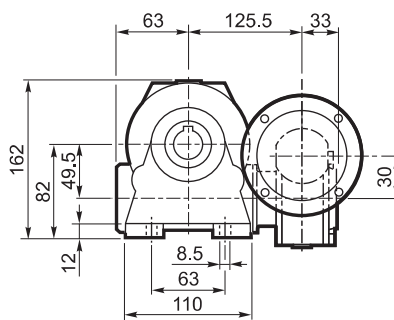
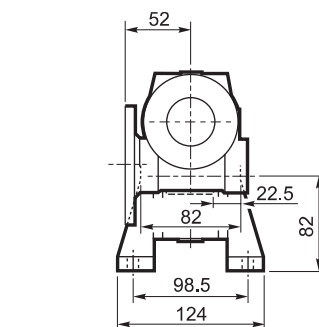
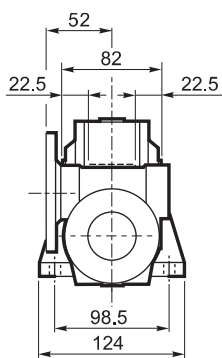

**V**

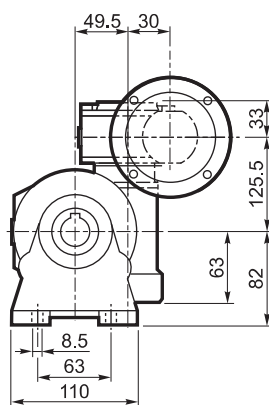
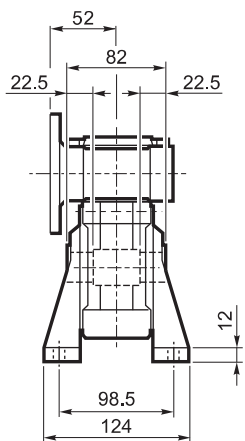

**P**

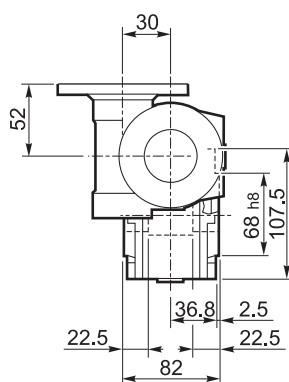
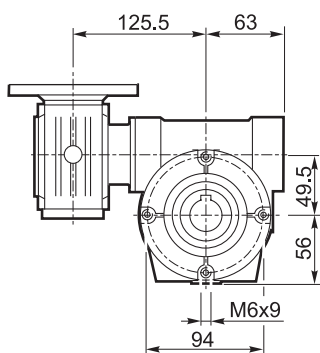

**INPUT**

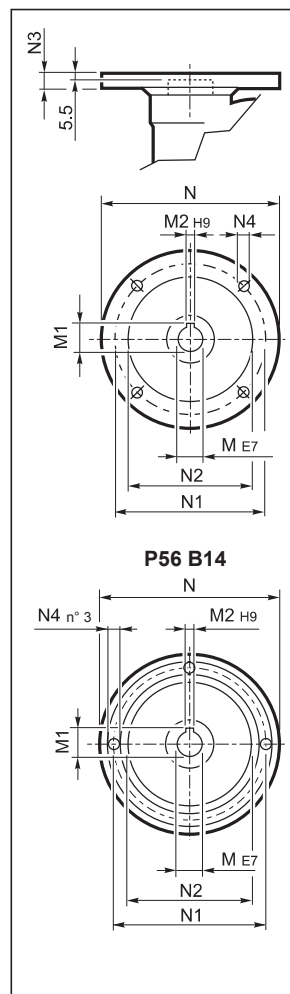

**OUTPUT**

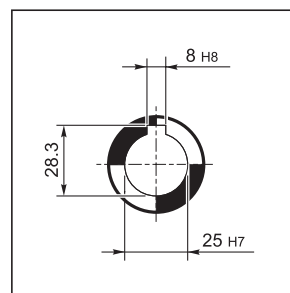





# VF/VF 30/49...P (IEC)

**F**

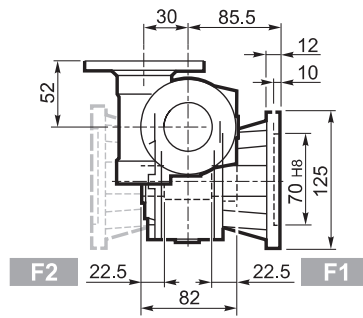
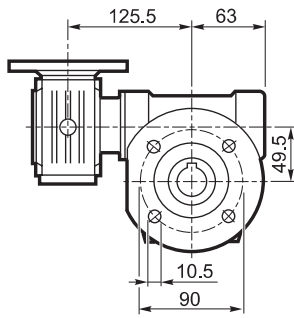

**INPUT**

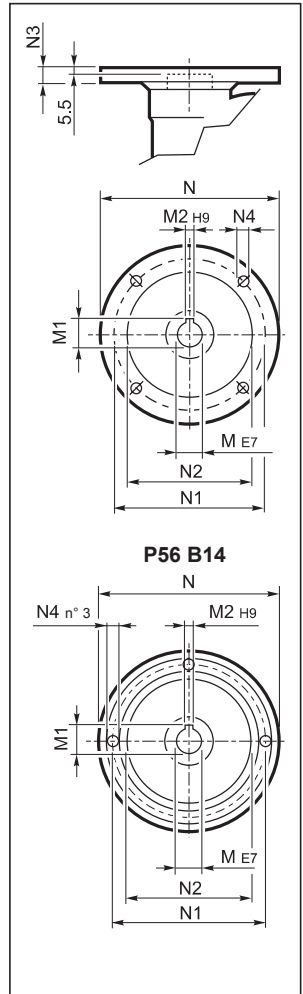

**FA**

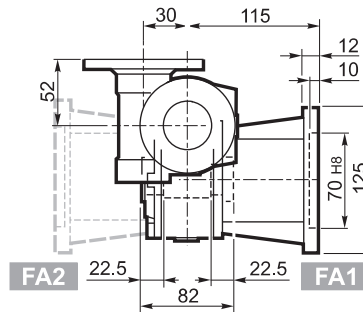
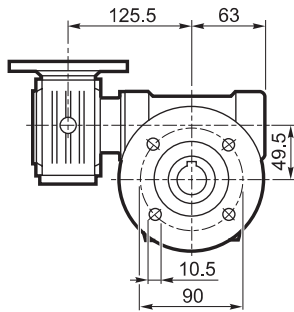

**OUTPUT**

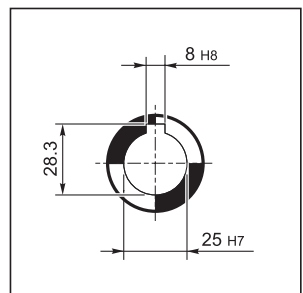

**U**

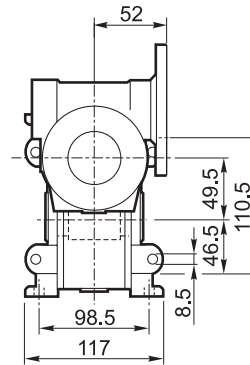
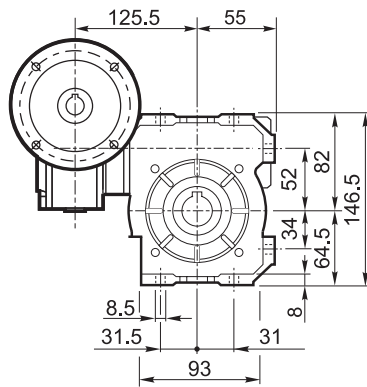

		M	M1	M2	N	N1	N2	N3	N4	
VF/VF 30/49	P56 B14	9	10.4	3	80	65	50	7	5.5	4.5
VF/VF 30/49	P63 B14	11	12.8	4	90	75	60	6	5.5	



# W 63...M/ME/MX/MXN

**U**

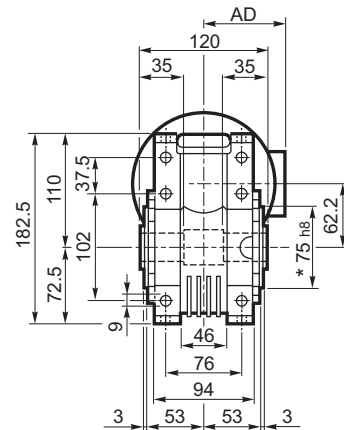
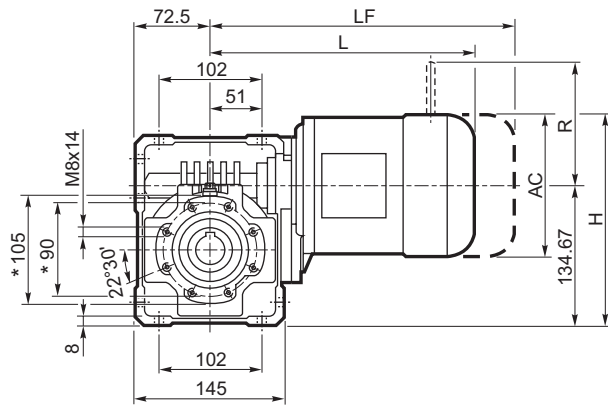

**UF\_**

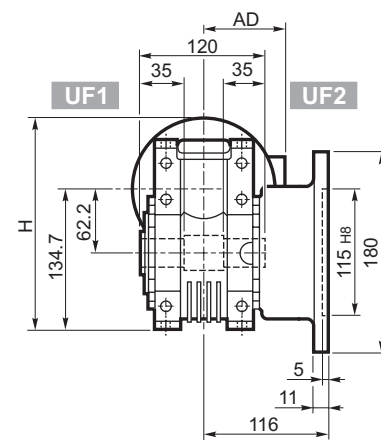
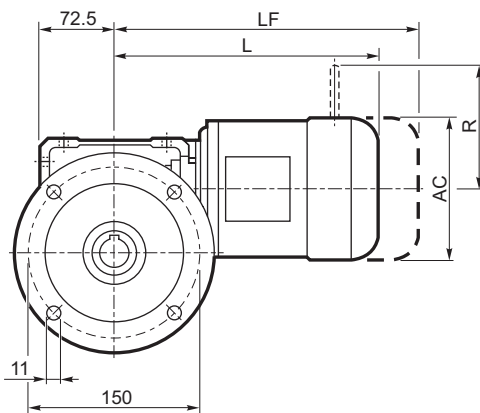

**UFC\_**

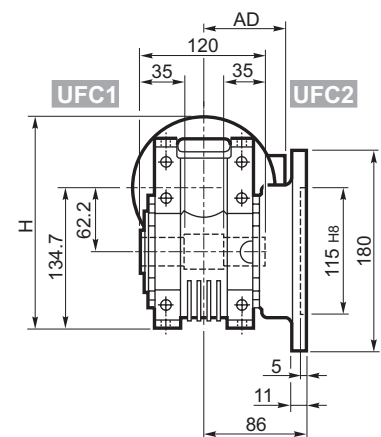
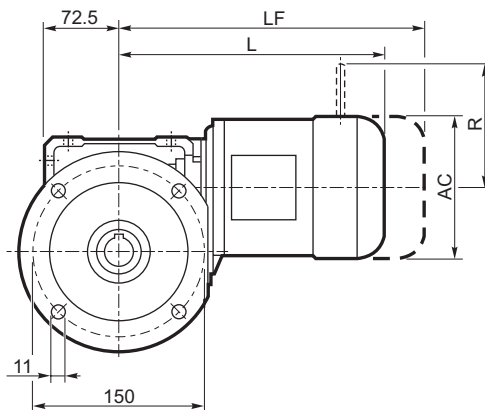

			M/ME/MX/MXN				M...FD		M...FA		M...FD		M...FA	
			AC	H	L	AD	Kg	LF	Kg	R	AD	R	AD	
W 63	S1	M1	138	204	289	108	13	350	15	103	135	124	108	
W 63	S1	ME1	138	204	289	108	13	411	15	103	135	124	135	
W 63	S10	MXN10	138	204	318	138	15.4	409	17.4	103	138	1214	138	
W 63	S2	M2S	156	213	317	119	17	393	20	129	146	134	119	
W 63	S2	ME2S	156	213	317	119	18.6	463	21.6	129	143	134	143	
W 63	S2	MX2S	156	213	361	119	22.4	465	25.4	129	143	134	143	
W 63	S20	MXN20	158	214	370.5	146	24.6	464	27.6	129	148	131	148	

**OUTPUT**

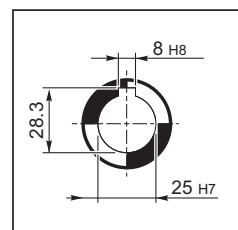

\* Da ambo i lati



# W 63...P (IEC)

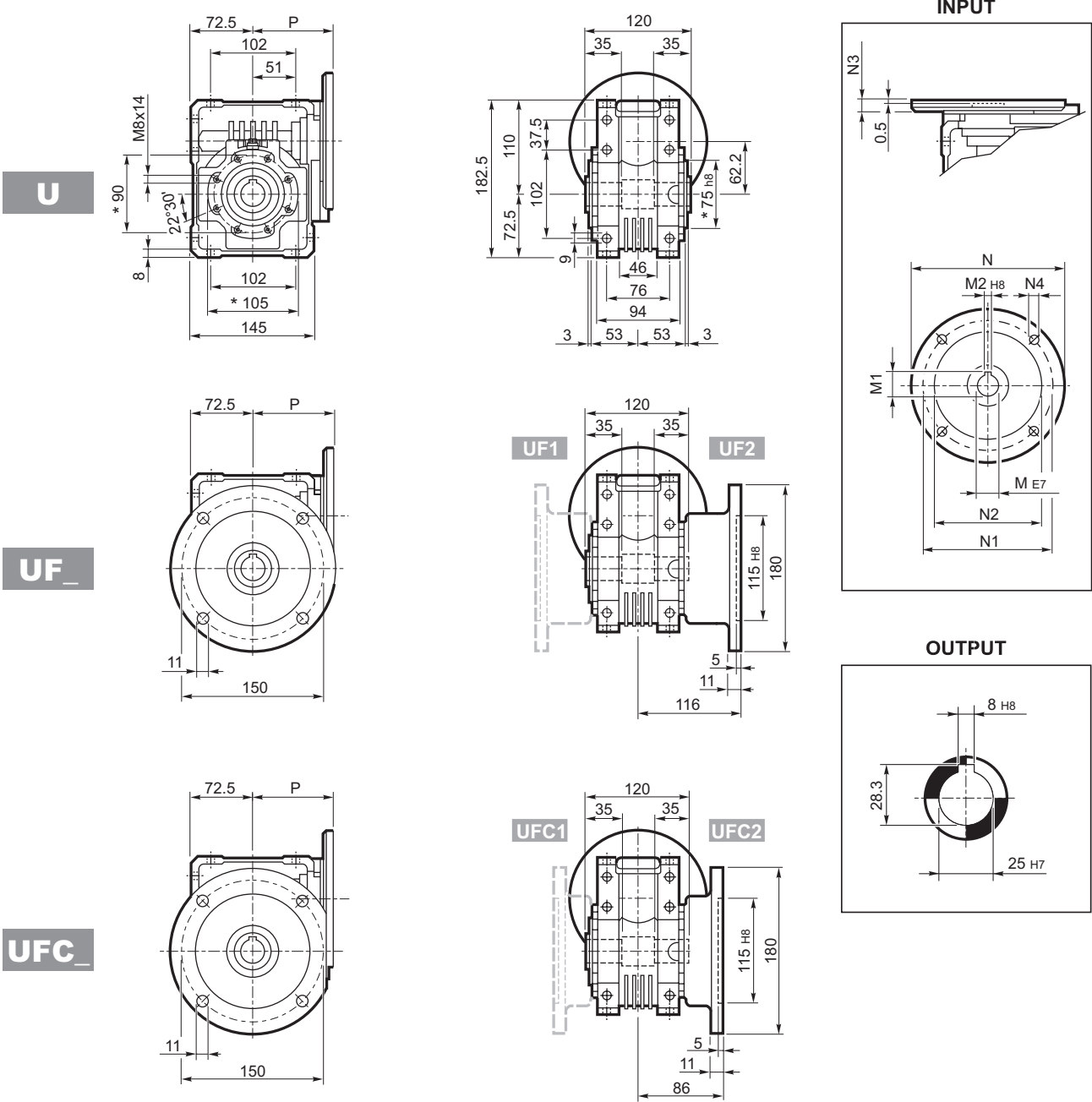

		M	M1	M2	N	N1	N2	N3	N4	P	
W 63	P71 B5	14	16.3	5	160	130	110	11	9	95	6.3
W 63	P80 B5	19	21.8	6	200	165	130	12	11.5	102	6.5
W 63	P90 B5	24	27.3	8	200	165	130	12	11.5	102	6.4
W 63	P71 B14	14	16.3	5	105	85	70	11	6.5	95	6.1
W 63	P80 B14	19	21.8	6	120	100	80	11	6.5	102	6.3
W 63	P90 B14	24	27.3	8	140	115	95	11	8.5	102	6.3



# WR 63...P (IEC)

**U**

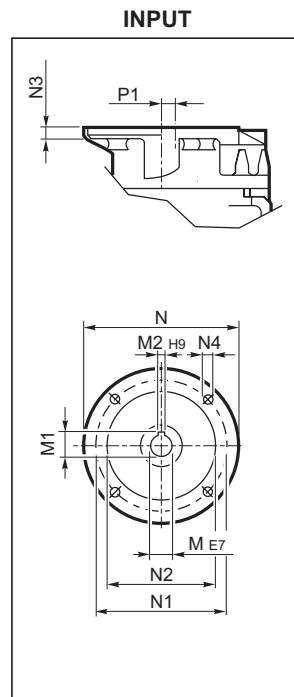
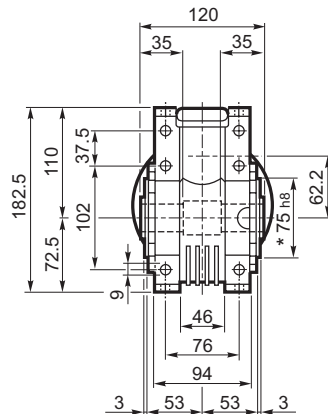
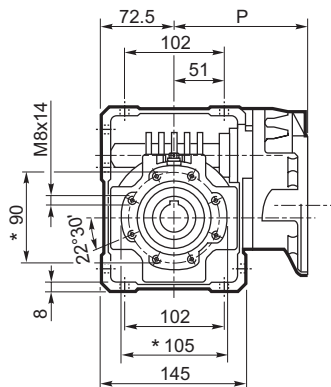

**UF\_**

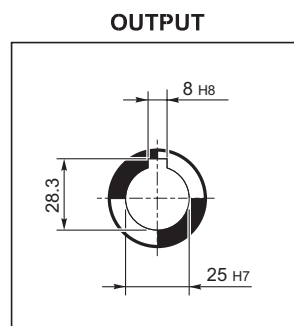
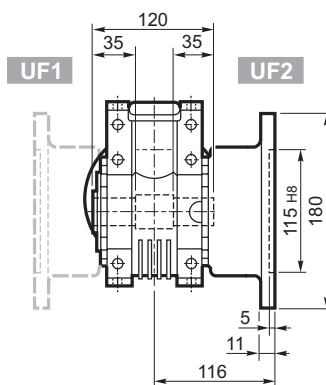
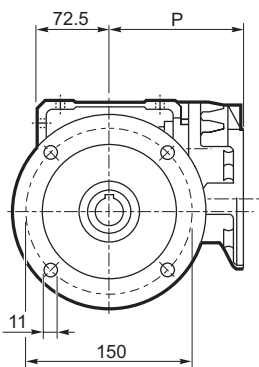

**UFC\_**

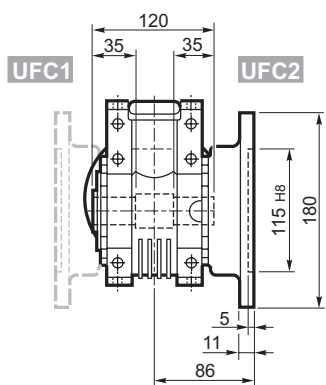
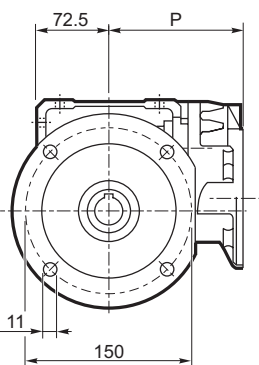

		M	M1	M2	N	N1	N2	N3	N4	P	P1	
WR 63	P63 B5	11	12.8	4	140	115	95	10	M8x10	133.5	11.42	7.1
WR 63	P71 B5	14	16.3	5	160	130	110	10	M8x10	133.5	11.42	

\* Da ambo i lati



# VF/W 30/63...P (IEC)

**U**

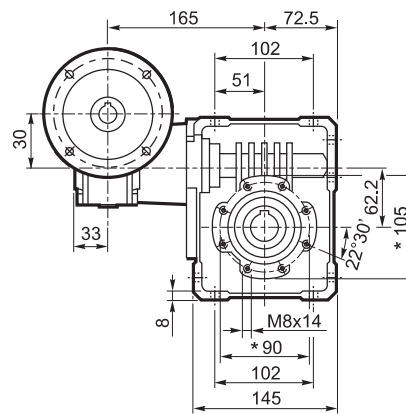
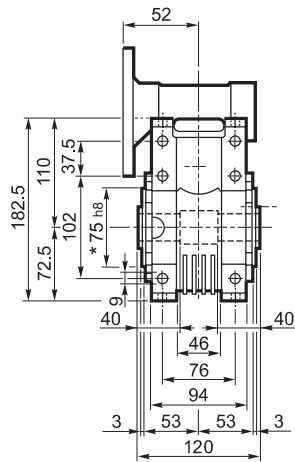

**INPUT**

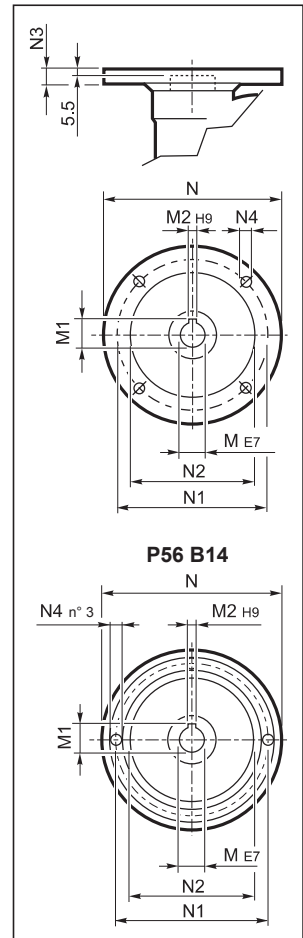

**UF\_**

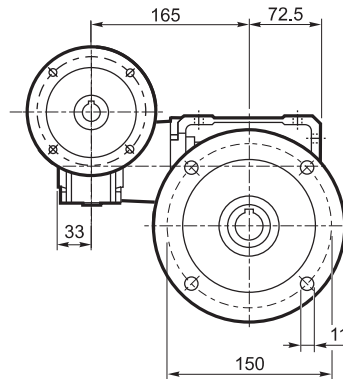
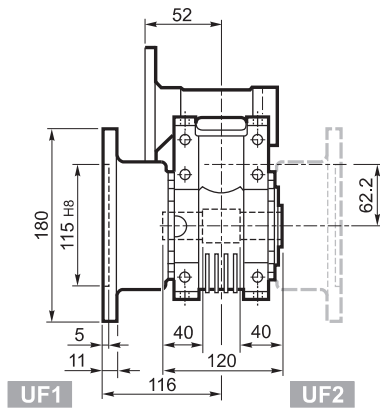

**UFC\_**

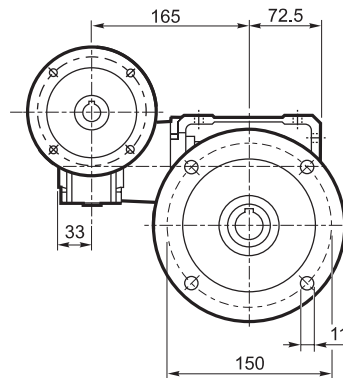
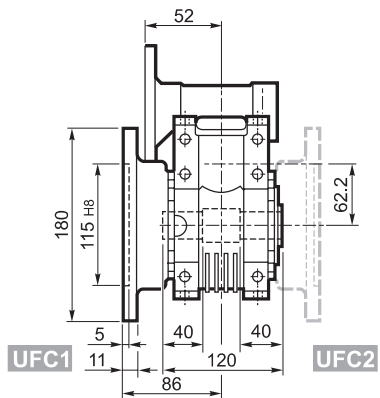

**OUTPUT**

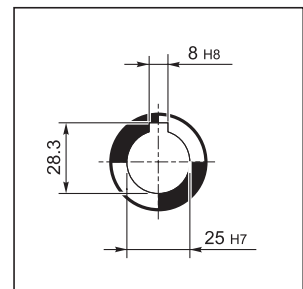

		M	M1	M2	N	N1	N2	N3	N4	
VF/W 30/63	P56 B5	9	10.4	3	120	100	80	7	7	8.0
VF/W 30/63	P63 B5	11	12.8	4	140	115	95	8	9.5	
VF/W 30/63	P56 B14	9	10.4	3	80	65	50	7	5.5	
VF/W 30/63	P63 B14	11	12.8	4	90	75	60	6	5.5	

\* Da ambo i lati



# W 75...M/ME/MX/MXN

**U**

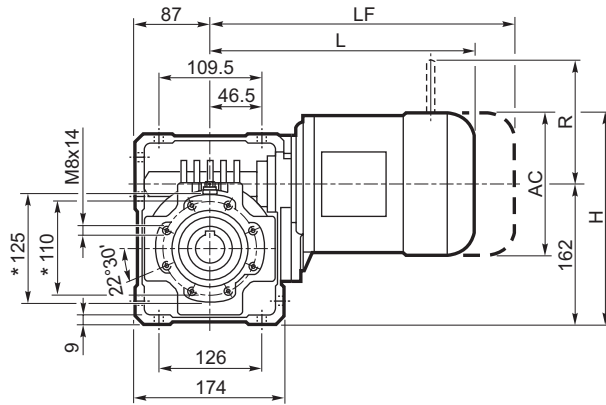

**UF\_**

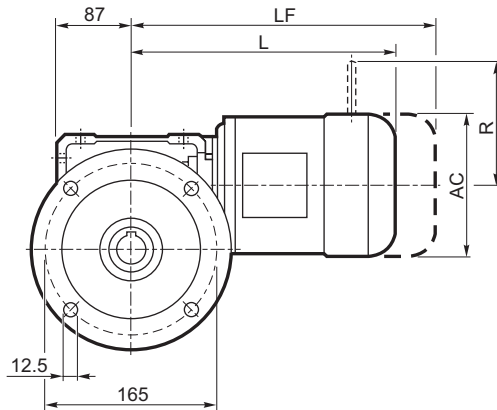

**UFC\_**

**UFCR\_#**

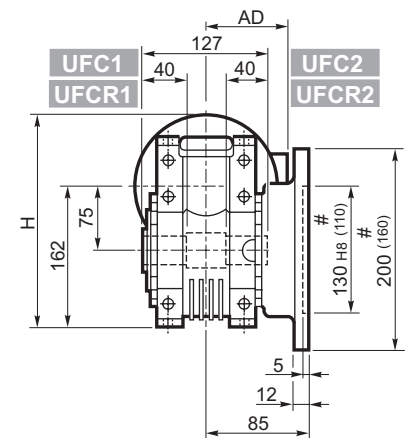
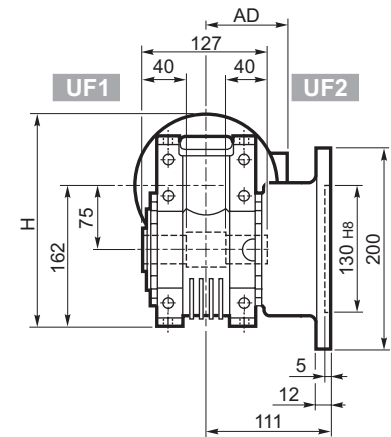
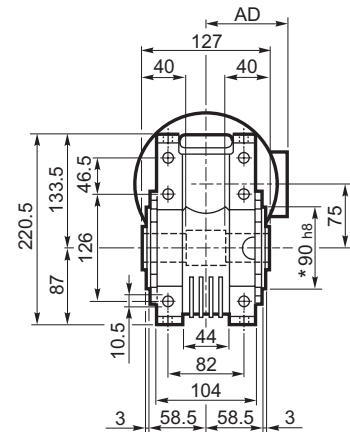
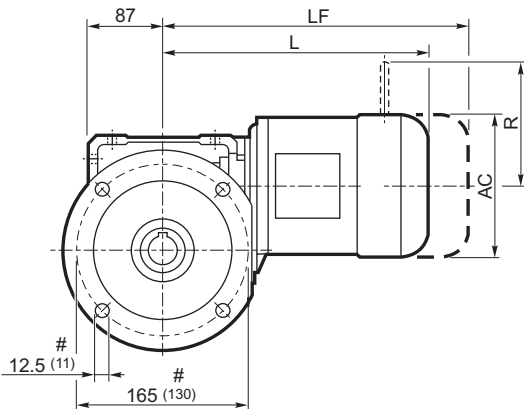

**STANDARD OUTPUT**

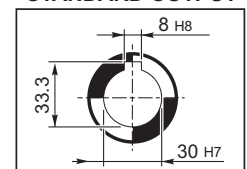

**ON REQUEST OUTPUT**

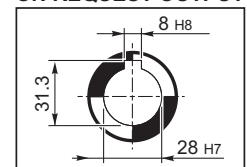

			M/ME/MX/MXN					M...FD M...FA		M...FD		M...FA	
			AC	H	L	AD	Kg	LF	Kg	R	AD	R	AD
W 75	S1	M1	138	231	308	108	16.0	369	18.2	103	135	124	108
W 75	S1	ME1	138	231	308	108	16.0	369	18.2	103	135	124	135
W 75	S10	MXN10	138	231	337	137	18.4	396	20.8	103	138	121	138
W 75	S2	ME2S	156	240	333	119	18.5	393	20.1	129	143	134	143
W 75	S2	MX2S	156	240	377	119	23.6	465	27.4	129	143	134	143
W 75	S20	MXN20	158	241	386.5	146	25.8	457.5	28	129	148	131	148
W 75	S3	ME3S	195	258.5	376	142	27.1	447	33.1	160	155	160	155
W 75	S3	MX3S	195	258.5	408	142	31.1	476	38.1	160	155	160	155
W 75	S3	ME3L	195	258.5	408	142	32.6	474	38.6	160	155	160	155
W 75	S3	MX3L	195	258.5	452	142	38.6	518	45.6	160	155	160	155

\* Da ambo i lati

# Flangia ridotta



## W 75...P (IEC)

**U**

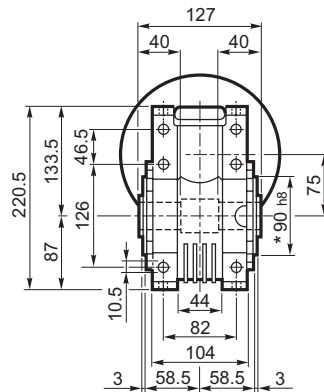
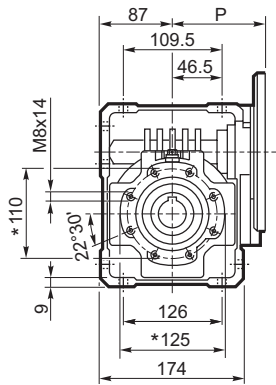

**INPUT**

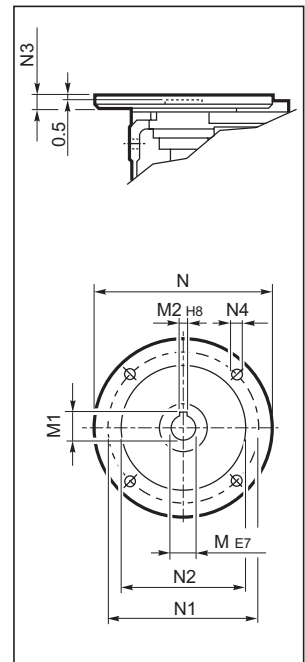

**UF\_**

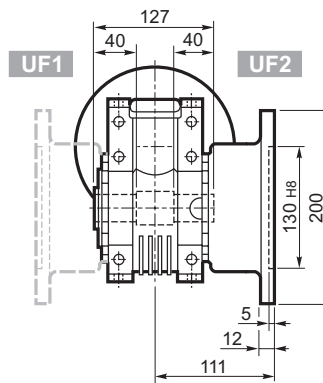
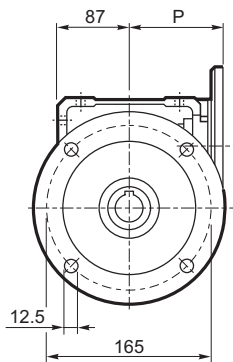

**STANDARD OUTPUT**

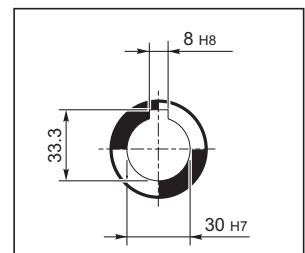

**UFC\_**

**UFCR\_#**

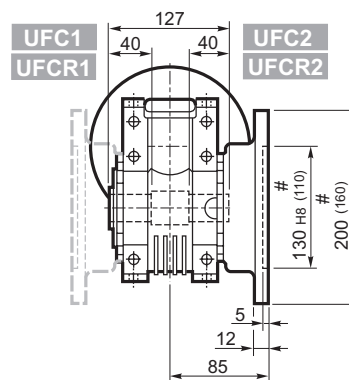
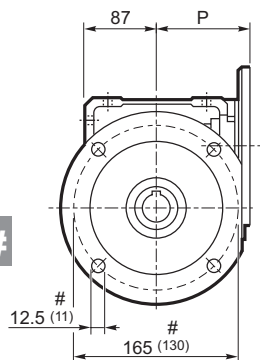

**ON REQUEST OUTPUT**

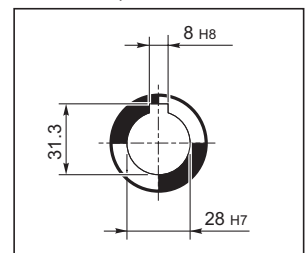

		M	M1	M2	N	N1	N2	N3	N4	P	
W 75	P71 B5	14	16.3	5	160	130	110	11	9	112	9.5
W 75	P80 B5	19	21.8	6	200	165	130	12	11.5	112	9.7
W 75	P90 B5	24	27.3	8	200	165	130	12	11.5	112	9.6
W 75	P100 B5	28	31.3	8	250	215	180	13	12.5	120	9.7
W 75	P112 B5	28	31.3	8	250	215	180	13	12.5	120	9.7
W 75	P80 B14	19	21.8	6	120	100	80	7.5	6.5	112	9.4
W 75	P90 B14	24	27.3	8	140	115	95	7.5	8.5	112	9.4
W 75	P100 B14	28	31.3	8	160	130	110	10	8.5	120	9.5
W 75	P112 B14	28	31.3	8	160	130	110	10	8.5	120	9.5

\* Da ambo i lati

# Flangia ridotta



# WR 75...P (IEC)

**U**

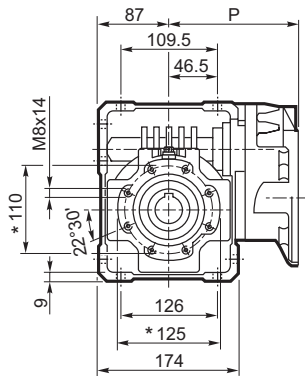

**UF\_**

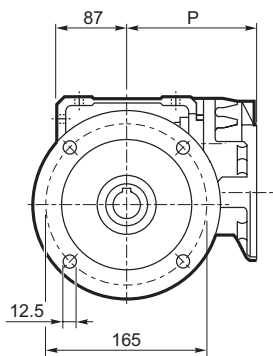

**UFC\_**

**UFCR\_#**

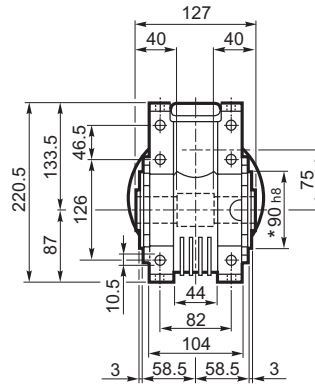
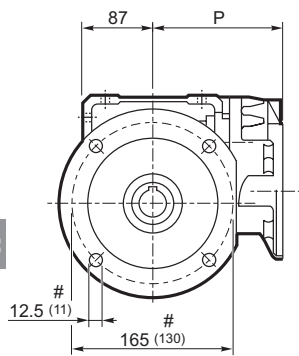

**UF1**

**UF2**

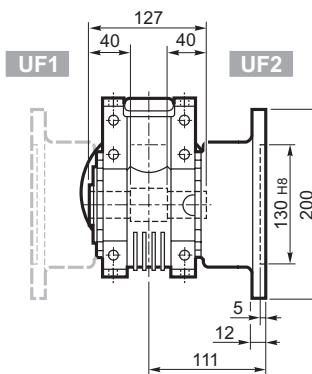

**UFC1**  
**UFCR1**

**UFC2**  
**UFCR2**

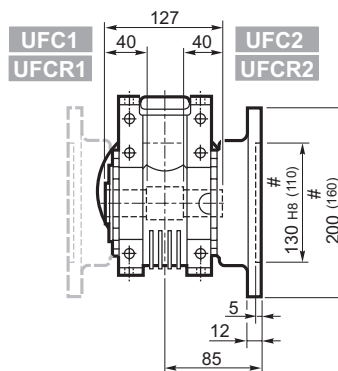

**INPUT**

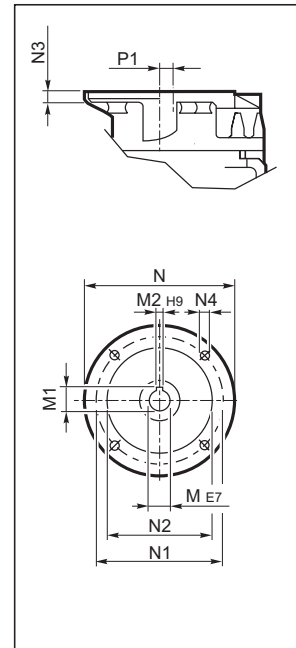

**STANDARD OUTPUT**

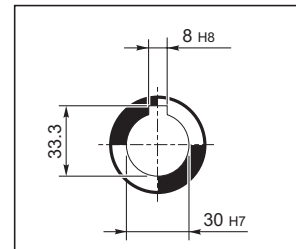

**ON REQUEST OUTPUT**

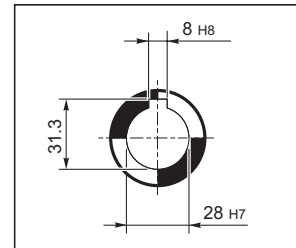

		M	M1	M2	N	N1	N2	N3	N4	P	P1	
WR 75	P63 B5	11	12.8	4	140	115	95	10	M8x10	152	23.53	10.6
WR 75	P71 B5	14	16.3	5	160	130	110	10	M8x10	152	23.53	10.7
WR 75	P80 B5	19	21.8	6	200	165	130	12	M10x13	163.5	11	11.5
WR 75	P90 B5	24	27.3	8	200	165	130	12	M10x13	163.5	11	11.6

\* Da ambo i lati

# Flangia ridotta



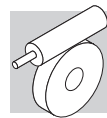

# VF/W 44/75...P (IEC)

**U**

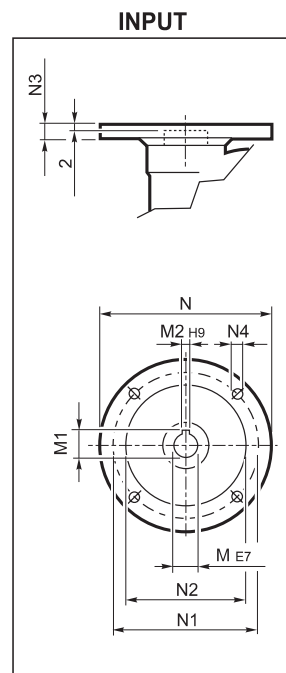
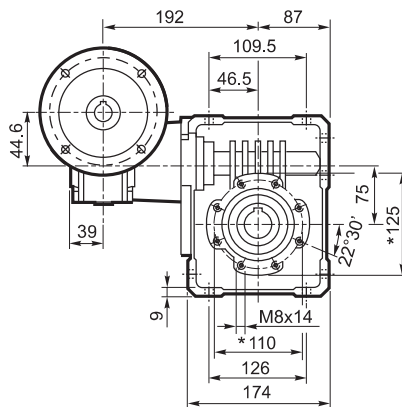
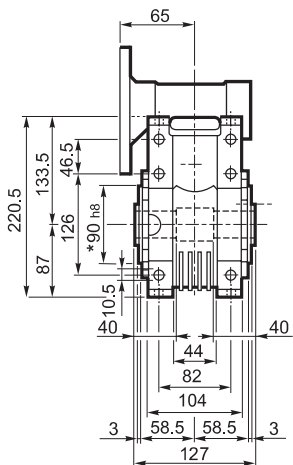

**UF**

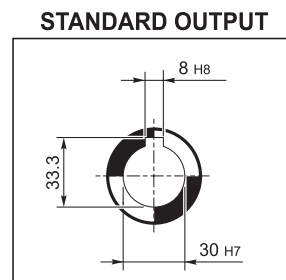
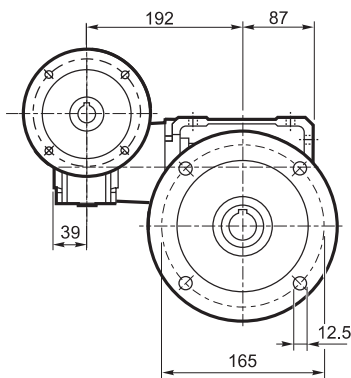
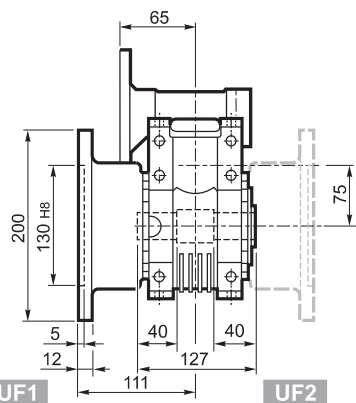

**UFC**

**UFCR #**

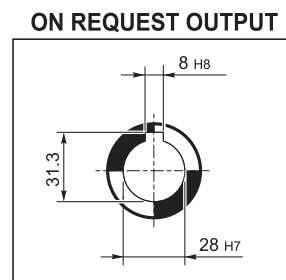
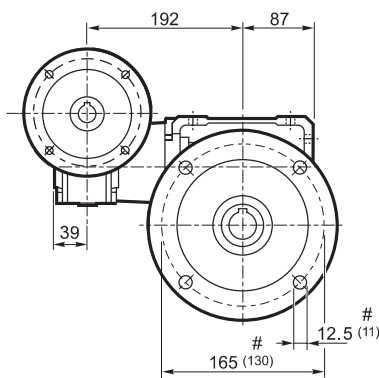
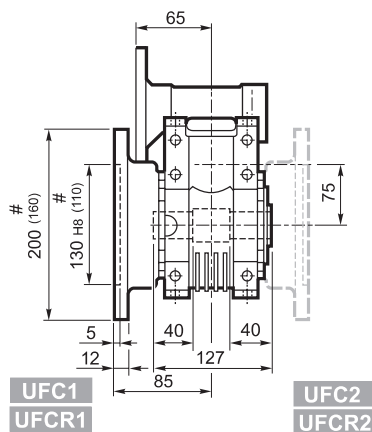

		M	M1	M2	N	N1	N2	N3	N4	Kg
VF/W 44/75	P63 B5	11	12.8	4	140	115	95	10	9.5	12.5
VF/W 44/75	P71 B5	14	16.3	5	160	130	110	10	9.5	
VF/W 44/75	P63 B14	11	12.8	4	90	75	60	8	5.5	
VF/W 44/75	P71 B14	14	16.3	5	105	85	70	10	7	

\* Da ambo i lati

# Flangia ridotta

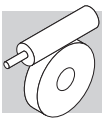

# W 86...M/ME/MX/MXN

**U**

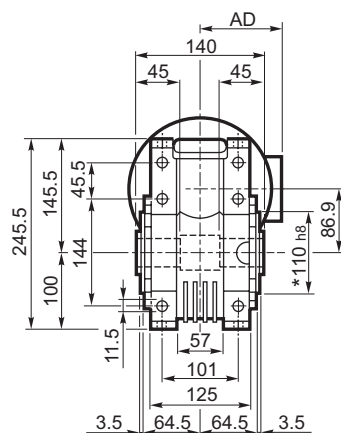
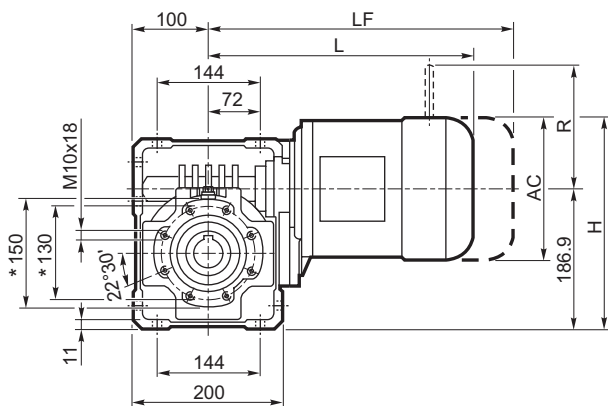

**UF**

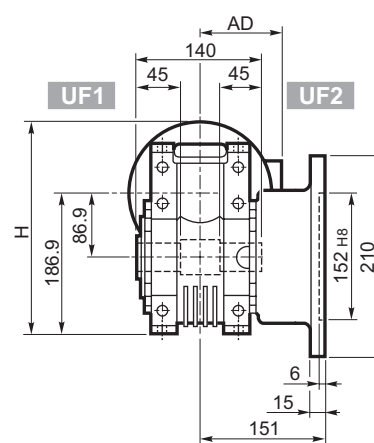
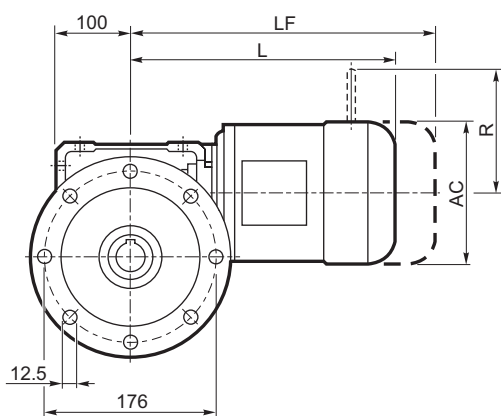

**UFC**

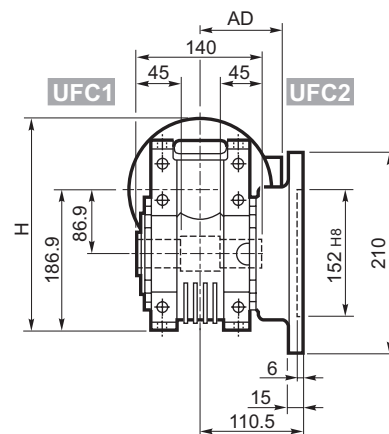
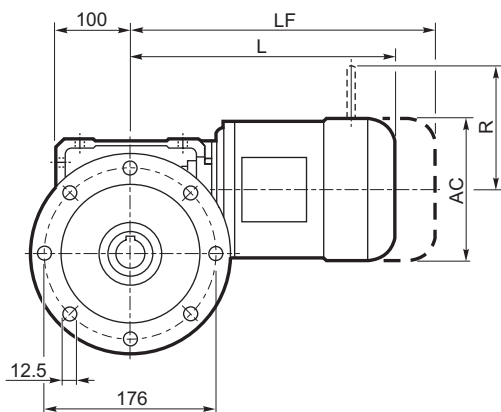

			M/ME/MX/MXN				M...FD		M...FA		M...FD		M...FA	
			AC	H	L	AD	Kg	LF	Kg	R	AD	R	AD	
W 86	S1	M1	138	256	324	108	20.1	385	22.3	103	135	124	108	
W 86	S1	ME1	138	256	324	108	20.1	385	22.3	103	135	124	135	
W 86	S10	MXN10	138	256	353	137	22.5	412	25.2	103	138	121	138	
W 86	S2	M2S	156	265	349	119	22.6	425	25.7	129	146	134	119	
W 86	S2	ME2S	156	265	349	119	24.2	410	25.8	129	143	134	143	
W 86	S2	MX2S	156	265	393	119	27.7	465	31.5	129	143	134	143	
W 86	S20	MXN20	158	266	402.5	146	29.9	473.5	33.8	129	148	131	148	
W 86	S3	ME3S	195	283.5	392	142	31.2	488	37.8	160	155	160	155	
W 86	S3	MX3S	195	283.5	424	142	34.2	514	41.2	160	155	160	155	
W 86	S3	ME3L	195	283.5	424	142	36.7	515	42.7	160	155	160	155	
W 86	S3	MX3L	195	283.5	468	142	42.7	560	49.7	160	155	160	155	

\* Da ambo i lati

**OUTPUT**

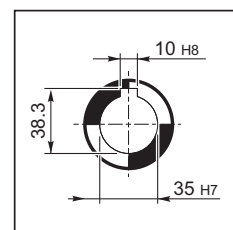



# W 86...P (IEC)

**U**

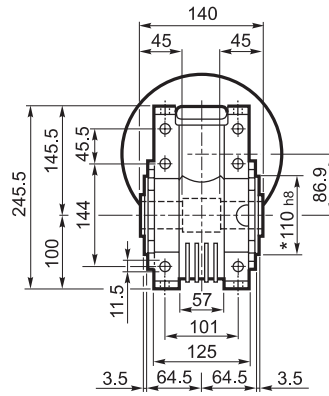
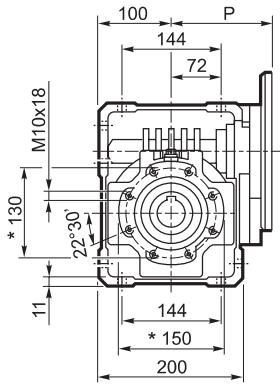

**INPUT**

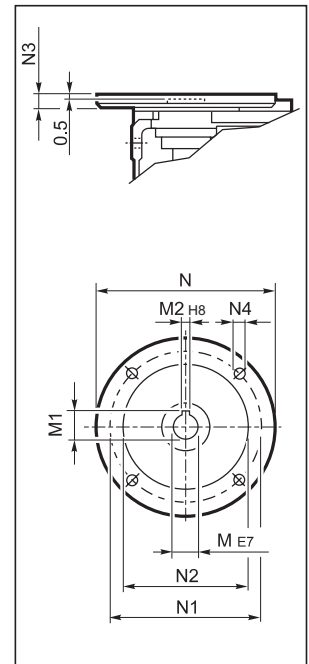

**UF\_**

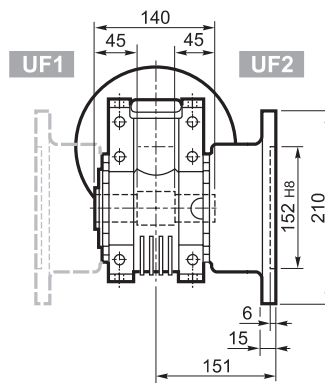
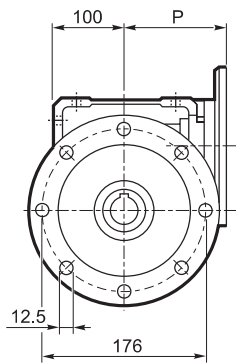

**OUTPUT**

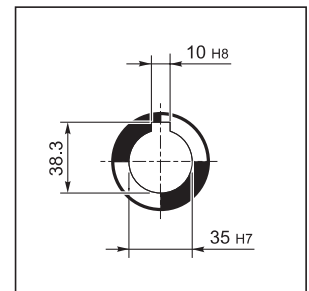

**UFC\_**

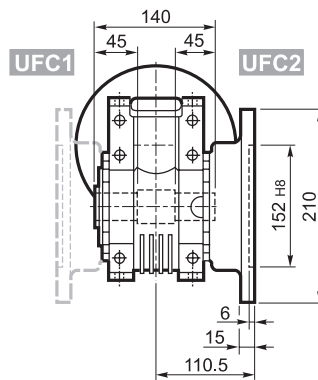
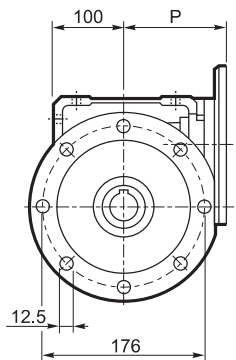

		M	M1	M2	N	N1	N2	N3	N4	P	
W 86	P71 B5	14	16.3	5	160	130	110	11	9	128	13.6
W 86	P80 B5	19	21.8	6	200	165	130	12	11.5	128	13.8
W 86	P90 B5	24	27.3	8	200	165	130	12	11.5	128	13.7
W 86	P100 B5	28	31.3	8	250	215	180	13	12.5	136	13.8
W 86	P112 B5	28	31.3	8	250	215	180	13	12.5	136	13.8
W 86	P80 B14	19	21.8	6	120	100	80	7.5	6.5	128	13.5
W 86	P90 B14	24	27.3	8	140	115	95	7.5	8.5	128	13.5
W 86	P100 B14	28	31.3	8	160	130	110	10	8.5	136	13.6
W 86	P112 B14	28	31.3	8	160	130	110	10	8.5	136	13.6

\* Da ambo i lati



# WR 86...P (IEC)

**U**

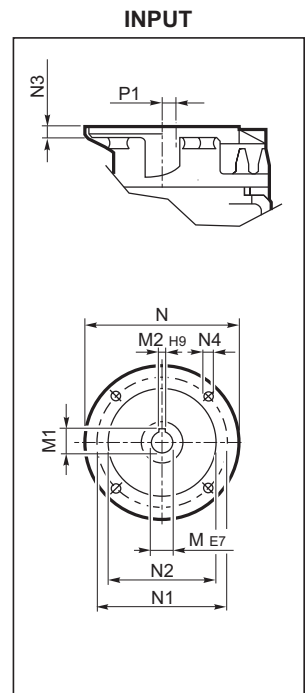
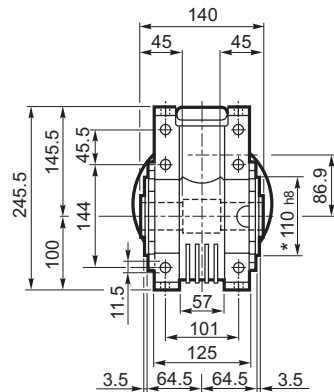
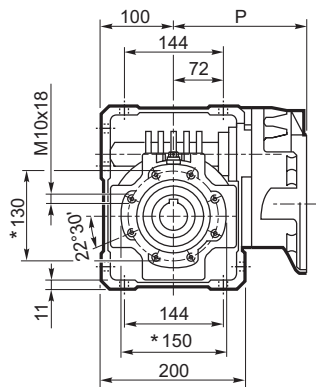

**UF**

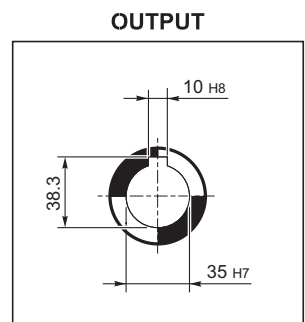
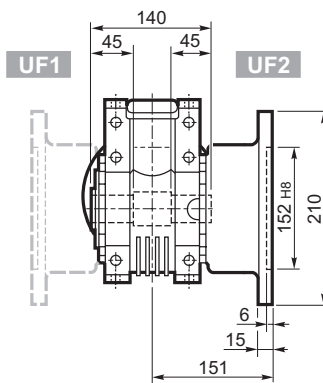
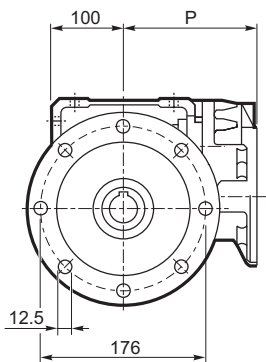

**UFC**

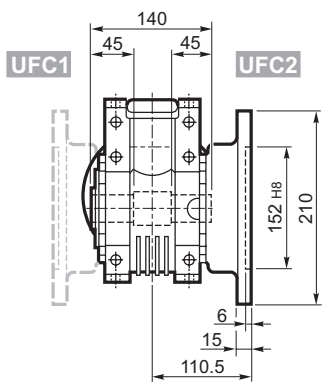
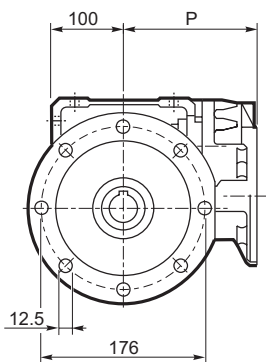

		M	M1	M2	N	N1	N2	N3	N4	P	P1	
WR 86	P63 B5	11	12.8	4	140	115	95	10	M8x10	168	35.4	14.3
WR 86	P71 B5	14	16.3	5	160	130	110	10	M8x10	168	35.4	14.4
WR 86	P80 B5	19	21.8	6	200	165	130	12	M10x13	179.5	22.9	15.2
WR 86	P90 B5	24	27.3	8	200	165	130	12	M10x13	179.5	22.9	15.3

\* Da ambo i lati



# VF/W 44/86... P (IEC)

**U**

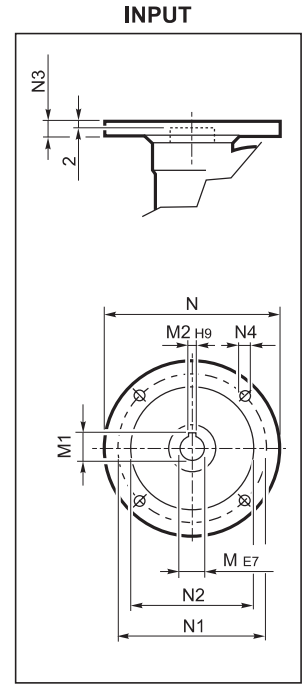
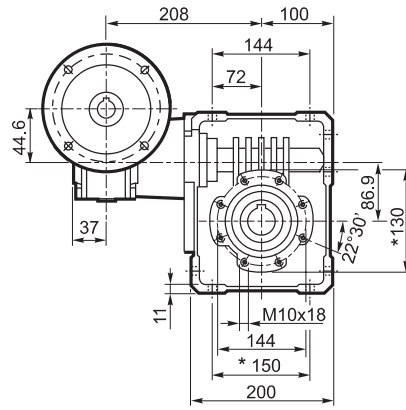
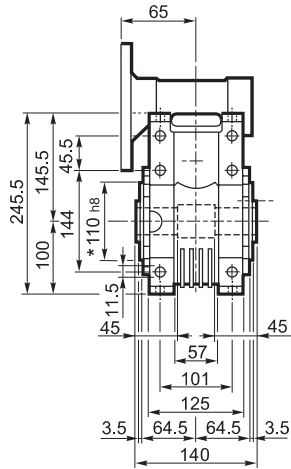

**UF**

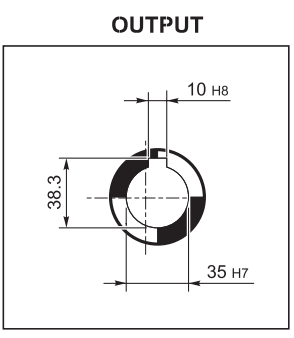
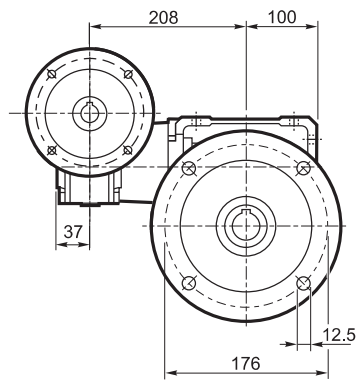
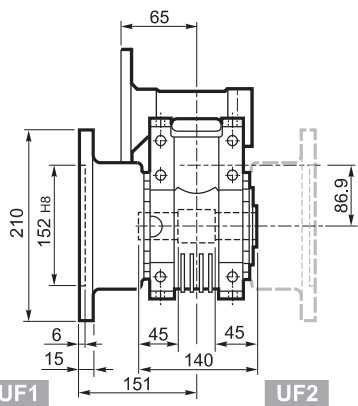

**UFC**

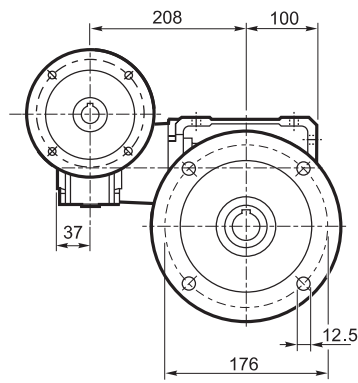
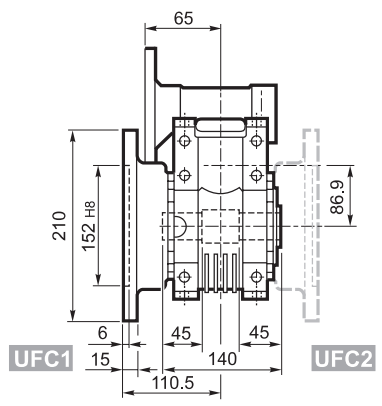

		M	M1	M2	N	N1	N2	N3	N4	
VF/W 44/86	P63 B5	11	12.8	4	140	115	95	10	9.5	16.6
VF/W 44/86	P71 B5	14	16.3	5	160	130	110	10	9.5	
VF/W 44/86	P63 B14	11	12.8	4	90	75	60	8	5.5	
VF/W 44/86	P71 B14	14	16.3	5	105	85	70	10	7	

\* Da ambo i lati



# W 110...M/ME/MX

**U**

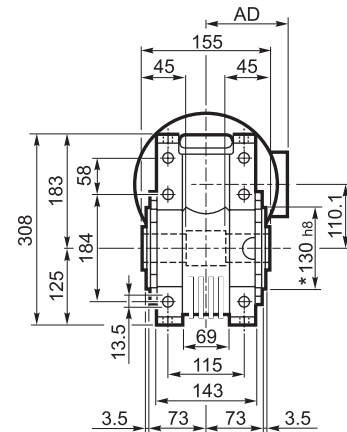
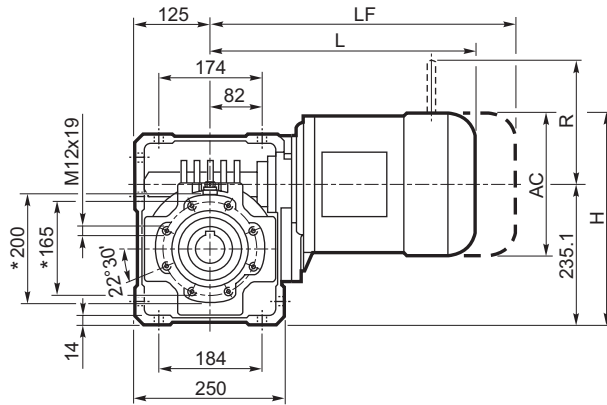

**UF**

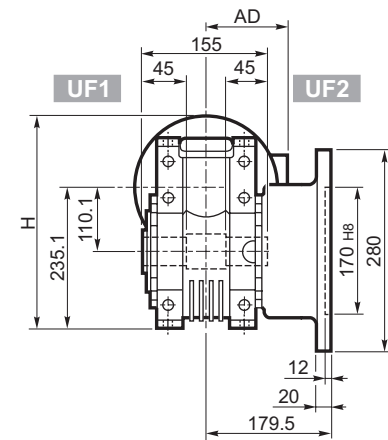
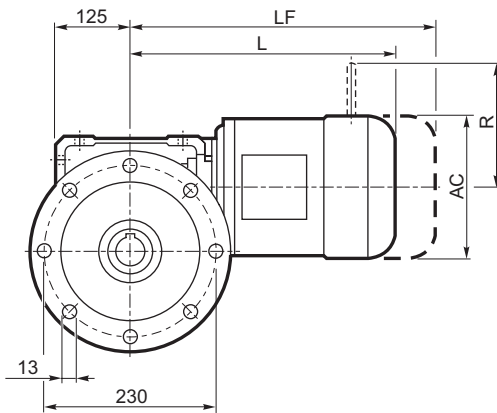

**UFC**

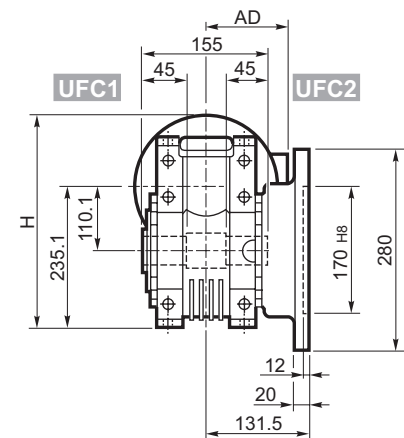
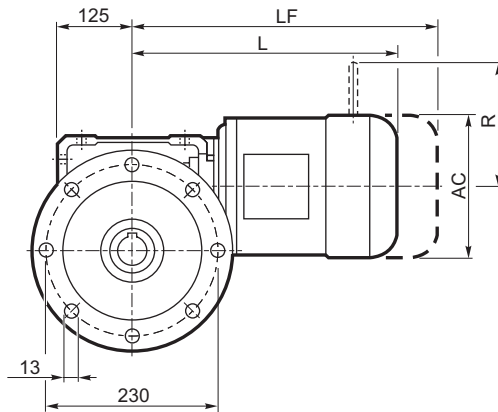

			M/ME/MX				Kg	M...FD M...FA		Kg	M...FD		M...FA	
			AC	H	L	AD		LF	R		AD	R	AD	
W 110	S2	M2S	156	313	364	119	38	440	41	129	146	134	119	
W 110	S2	ME2S	156	313	364	119	38	440	39.6	129	143	134	143	
W 110	S2	MX2S	156	313	408	119	43.1	480	46.9	129	143	134	143	
W 110	S3	ME3S	195	332	407	142	47.5	503	53.5	160	155	160	155	
W 110	S3	MX3S	195	332	440	142	50.5	530	57.5	160	155	160	155	
W 110	S3	ME3L	195	332	439	142	53	530	59	160	155	160	155	
W 110	S3	MX3L	195	332	483	142	59	575	66	160	155	160	155	

**OUTPUT**

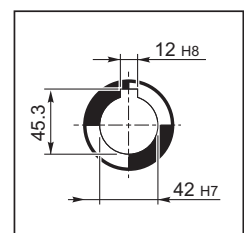

\* Da ambo i lati



# W 110...P (IEC)

**U**

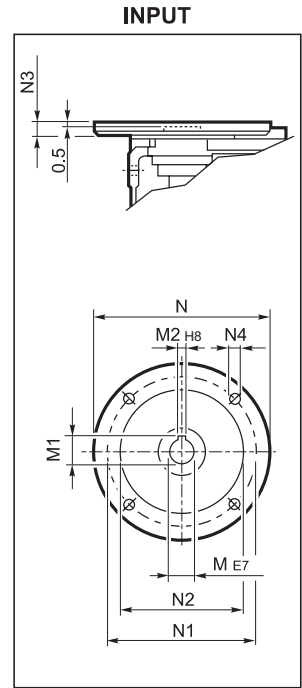
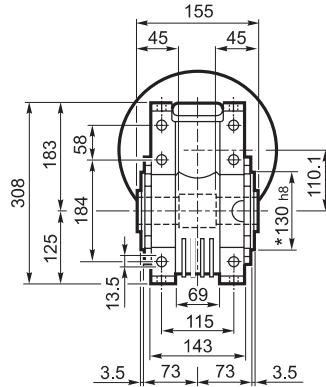
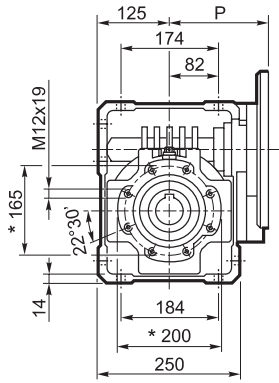

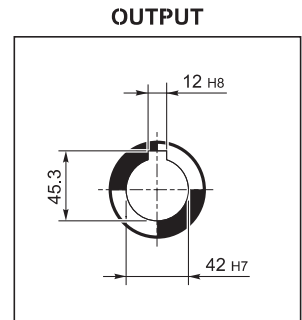
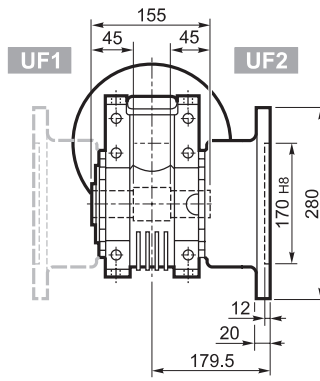
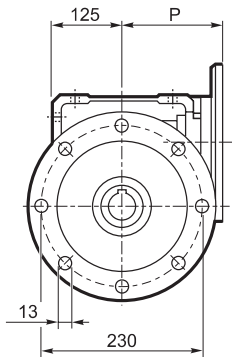

**UF\_**

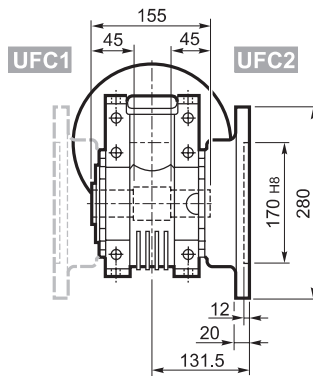
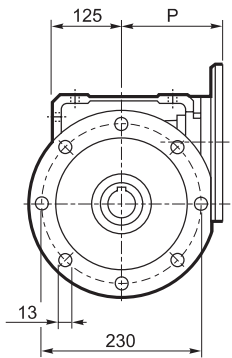

**UFC\_**



		M	M1	M2	N	N1	N2	N3	N4	P	
W 110	P80 B5	19	21.8	6	200	165	130	—	M10x12	143	28
W 110	P90 B5	24	27.3	8	200	165	130	—	M10x12	143	28
W 110	P100 B5	28	31.3	8	250	215	180	13	13	151	29
W 110	P112 B5	28	31.3	8	250	215	180	13	13	151	29
W 110	P132 B5	38	41.3	10	300	265	230	16	14	226	31
W 110	P80 B14	19	21.8	6	120	100	80	7.5	7	143	27.5
W 110	P90 B14	24	27.3	8	140	115	95	6.5	9	143	27.5
W 110	P100 B14	28	31.3	8	160	130	110	13	9	151	27
W 110	P112 B14	28	31.3	8	160	130	110	13	9	151	27

\* Da ambo i lati



## WR 110...P (IEC)

**U**

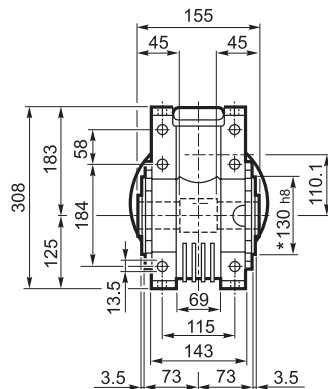
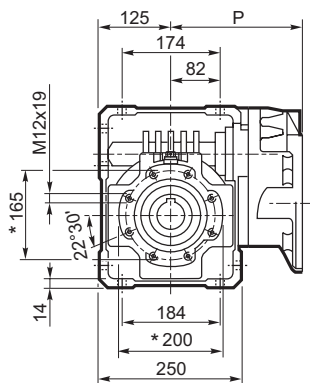

**INPUT**

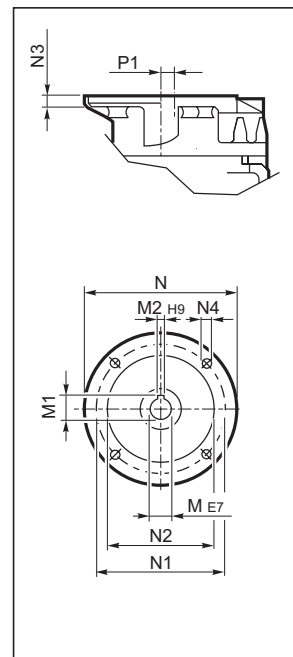

**UF\_**

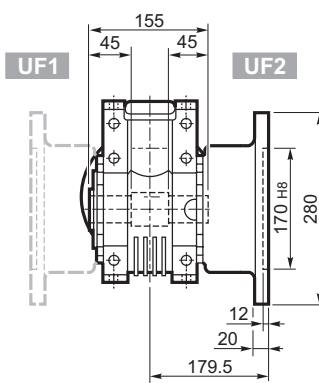
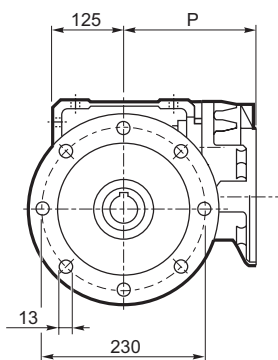

**OUTPUT**

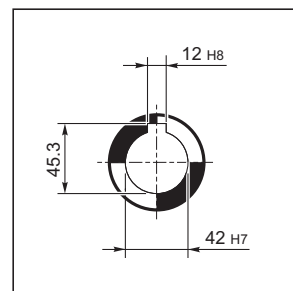

**UFC\_**

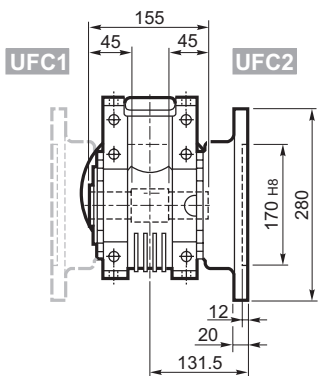
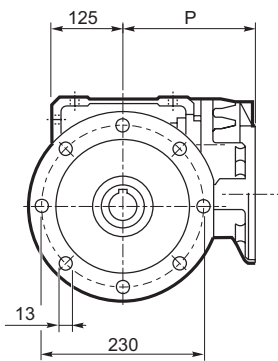

		M	M1	M2	N	N1	N2	N3	N4	P	P1	kg		
		WR 110	P71 B5	14	16.3	5	160	130	110	10	M8x14	185	58.6	30.5
		WR 110	P80 B5	19	21.8	6	200	165	130	14	M10x15	204	21.1	31
		WR 110	P90 B5	24	27.3	8	200	165	130	14	M10x15	204	21.1	31
		WR 110	P100 B5	28	31.3	8	250	215	180	14	M12x13	213	21.1	32
		WR 110	P112 B5	28	31.3	8	250	215	180	14	M12x13	213	21.1	32

\* Da ambo i lati





# VF/W 49/110...P (IEC)

**U**

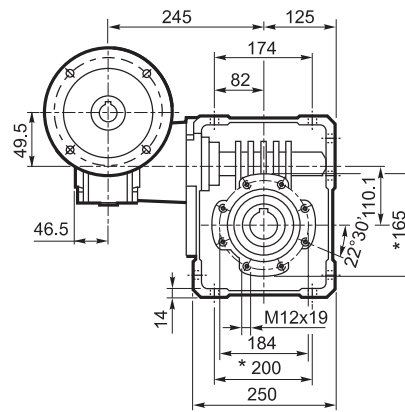
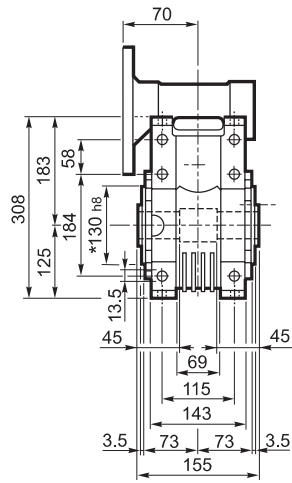

**INPUT**

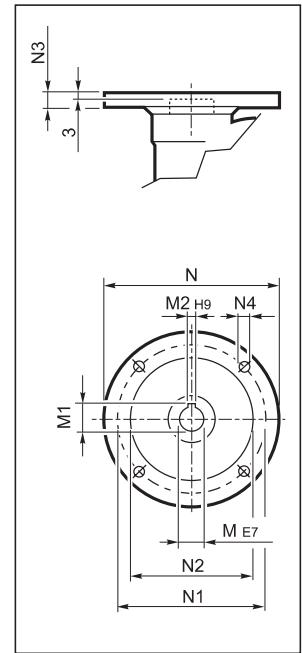

**UF**

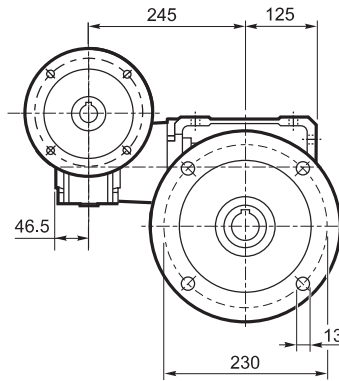
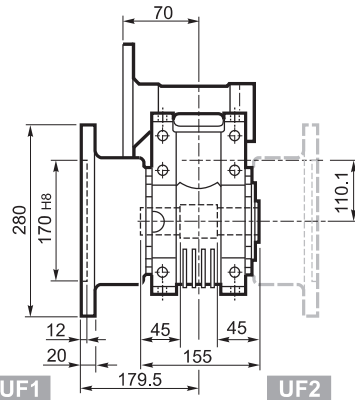

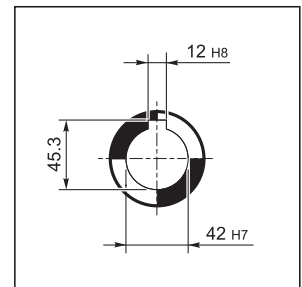

**OUTPUT**

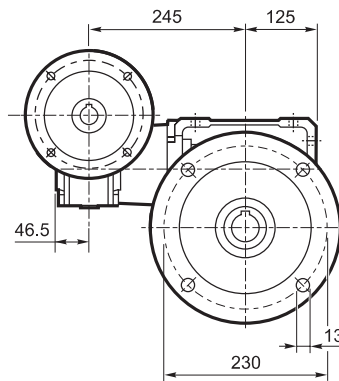
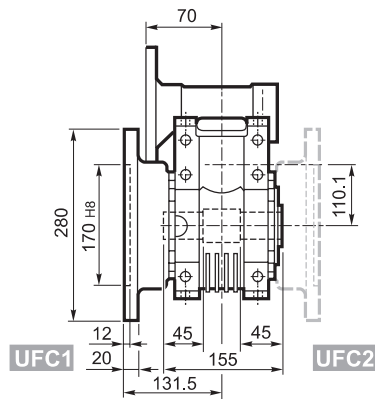

**UFC**



		M	M1	M2	N	N1	N2	N3	N4	
VF/W 49/110	P63 B5	11	12.8	4	140	115	95	10.5	9.5	33
VF/W 49/110	P71 B5	14	16.3	5	160	130	110	10.5	9.5	
VF/W 49/110	P80 B5	19	21.8	6	200	165	130	10	11.5	
VF/W 49/110	P63 B14	11	12.8	4	90	75	60	7	6	
VF/W 49/110	P71 B14	14	16.3	5	105	85	70	10.5	6.5	
VF/W 49/110	P80 B14	19	21.8	6	120	100	80	10	7	

\* Da ambo i lati



# VF 130...P (IEC)

**A**

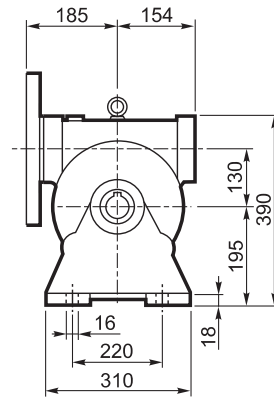
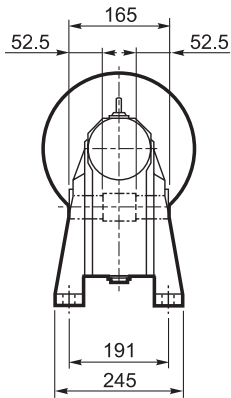

**N**

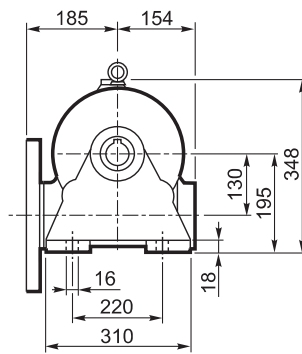
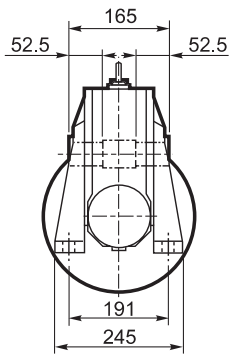

**V**

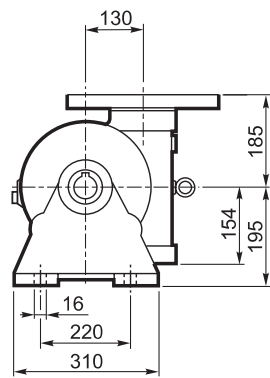
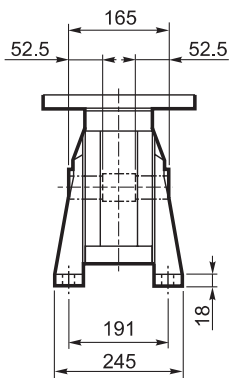

**INPUT**

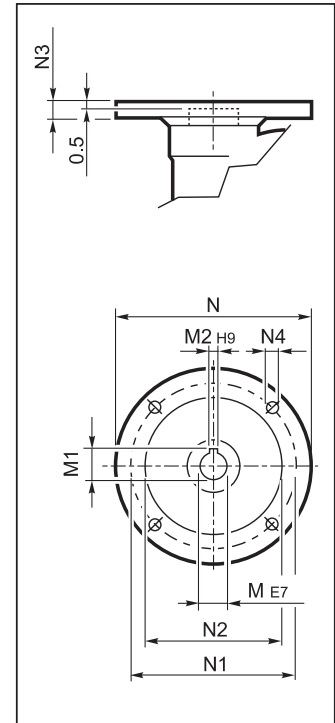

**OUTPUT**

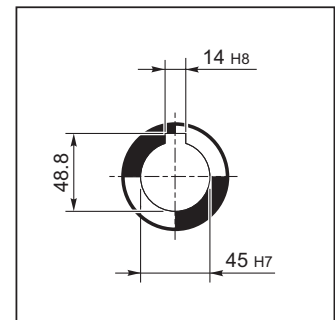



## VF 130...P (IEC)

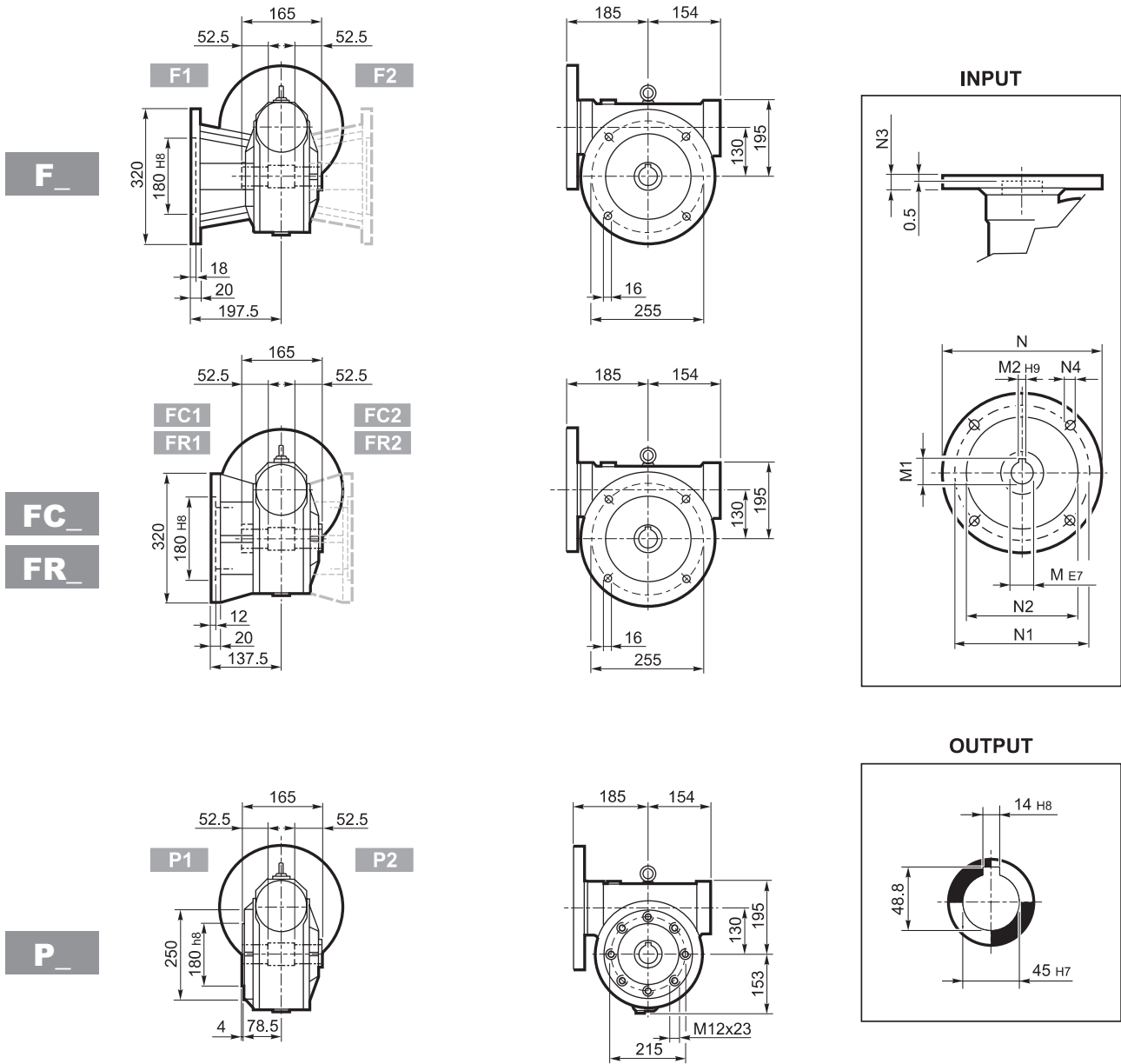

		M	M1	M2	N	N1	N2	N3	N4	
VF130	P90 B5	24	27.3	8	200	165	130	17	11	49
VF130	P100 B5	28	31.3	8	250	215	180	17	13	
VF130	P112 B5	28	31.3	8	250	215	180	17	13	
VF130	P132 B5	38	40.1#	10	300	265	230	17	13	

# Linguetta ribassata



# VFR 130...P (IEC)

**A**

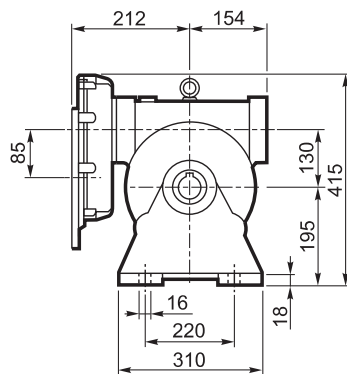
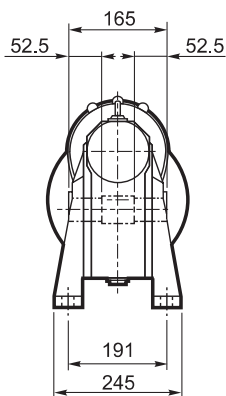

**INPUT**

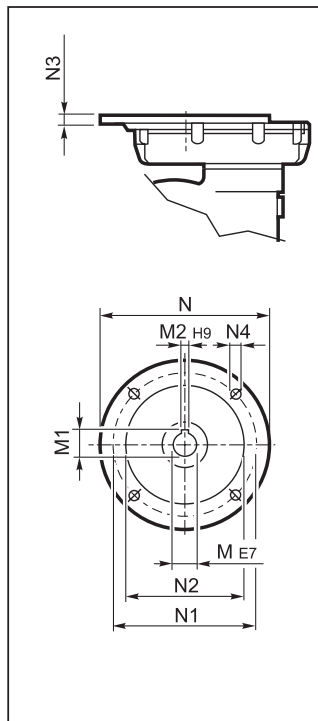

**N**

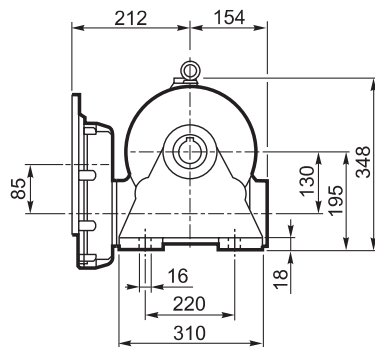
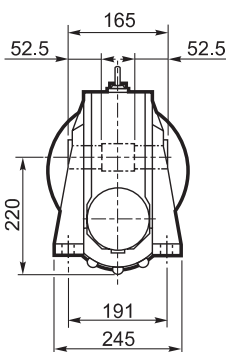

**OUTPUT**

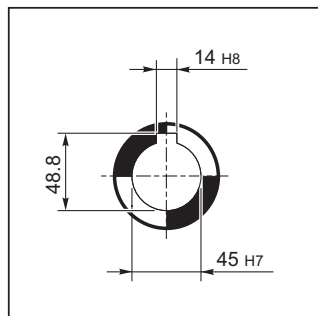



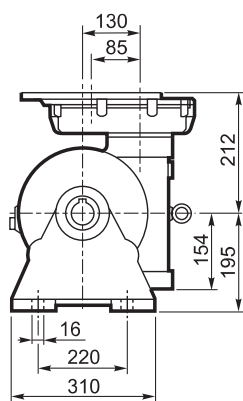
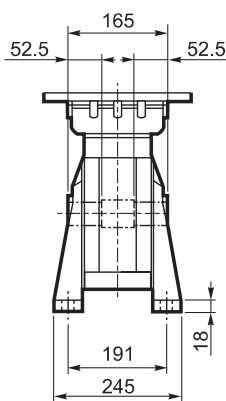

**V**



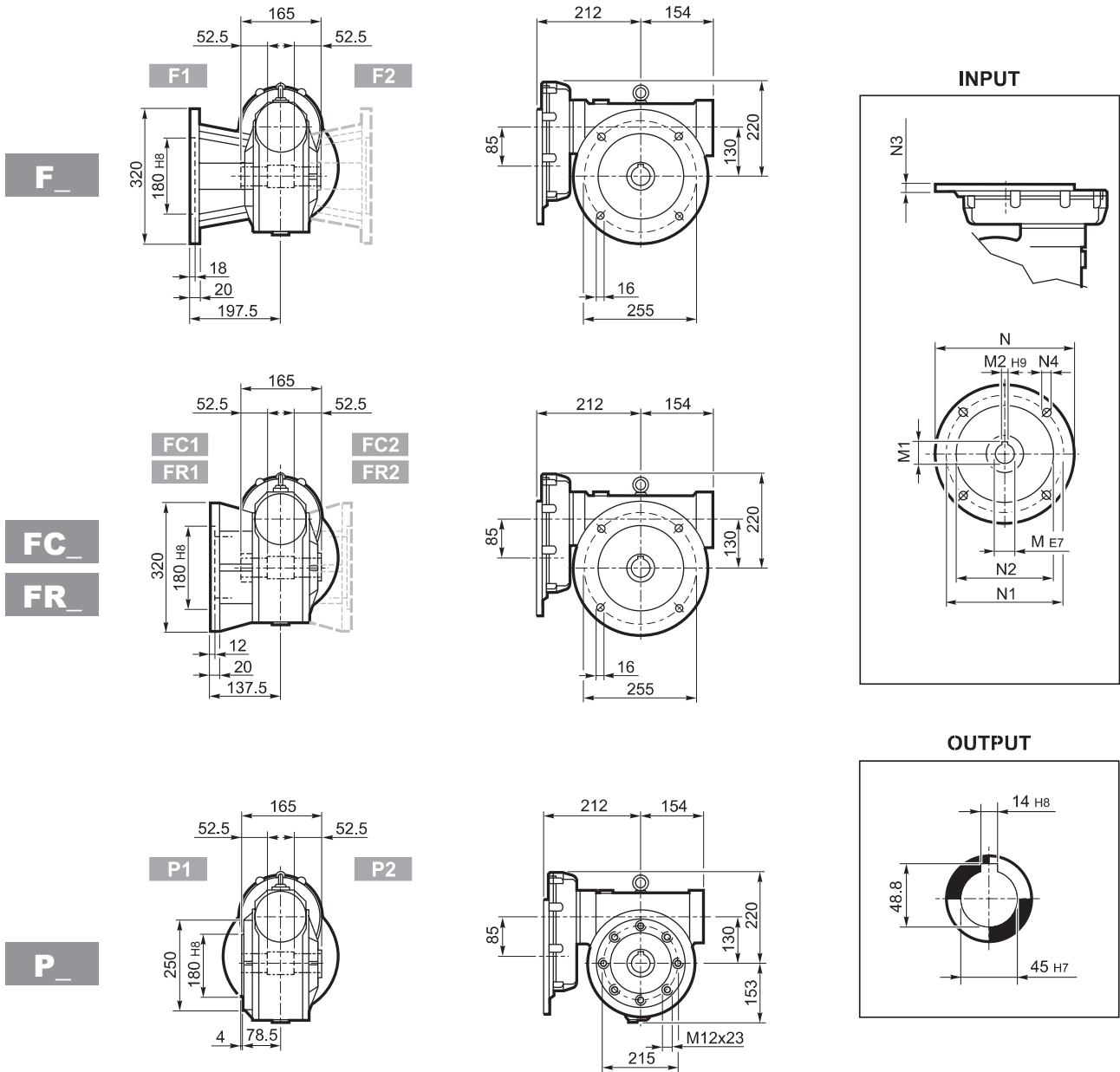

## VFR 130...P (IEC)



		M	M1	M2	N	N1	N2	N3	N4	
VFR 130	P80 B5	19 K6	21.8	6	200	165	130	12	M10x25	57
VFR 130	P90 B5	24 K6	27.3	8	200	165	130	12	M10x25	
VRF 130	P100 B5	28 J6	29.1#	8	250	215	180	13	M12x35	
VRF 130	P112 B5	28 J6	29.1#	8	250	215	180	13	M12x35	

# Linguetta ribassata



# W/VF 63/130...M/ME/MX/MXN

**A**

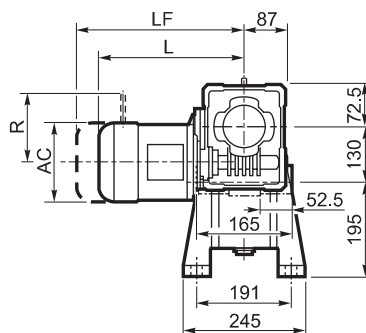
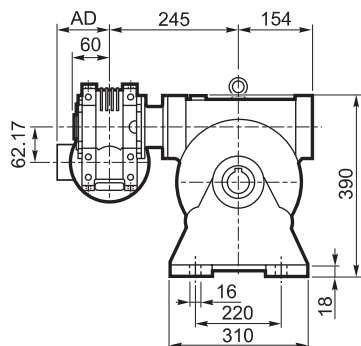

**OUTPUT**

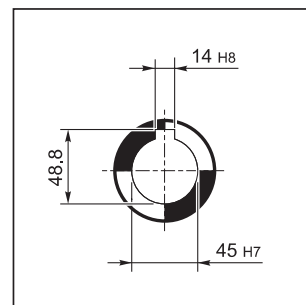

**N**

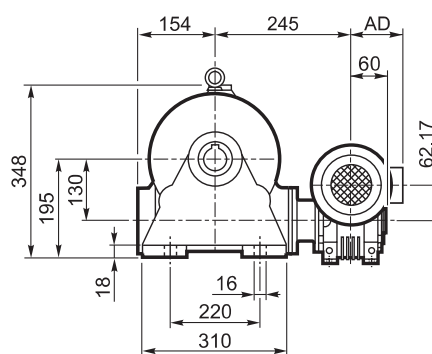
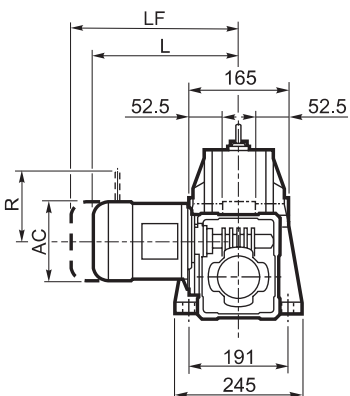

**V**

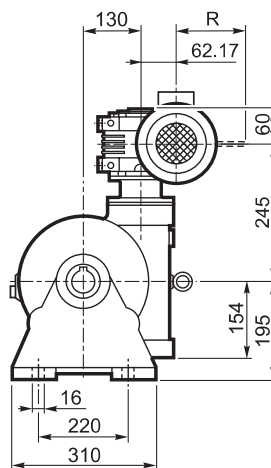
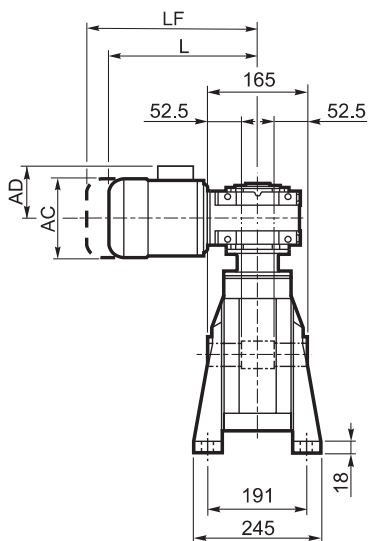



## W/VF 63/130...M/ME/MX/MXN

**F\_**  
**FC\_**  
**FR\_**

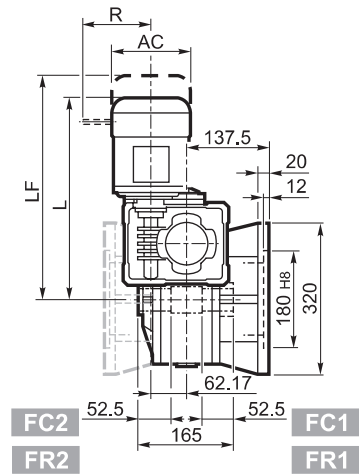
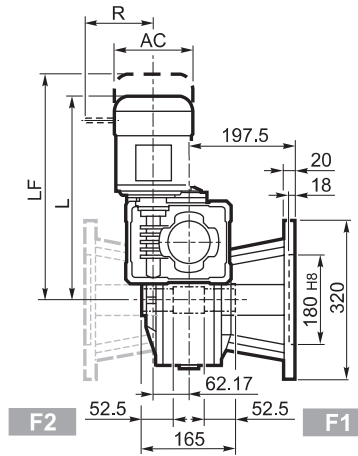
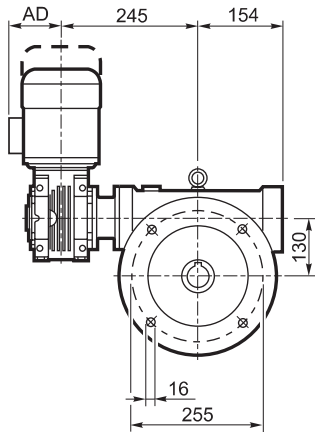

**P\_**

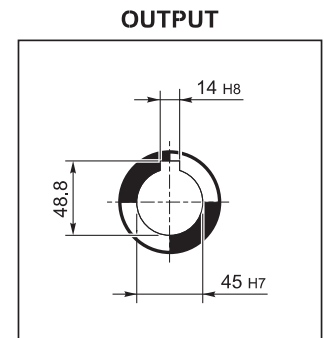
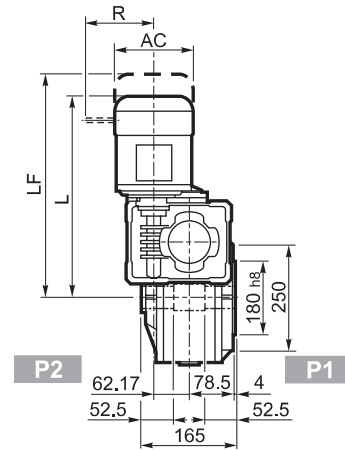
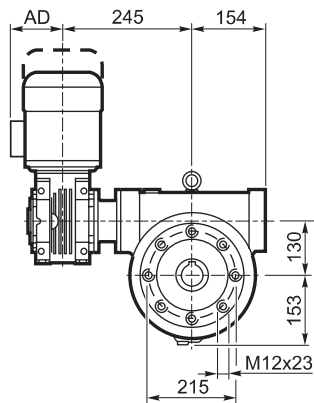

			M/ME/MX/MXN				M...FD M...FA		M...FD		M...FA	
			AC	L	AD	Kg	LF	Kg	R	AD	R	AD
W/VF 63/130	S1	M1	138	419	108	63	480	65	103	135	124	108
W/VF 63/130	S1	ME1	138	419	108	63	480	65	103	135	124	108
W/VF 63/130	S10	MXN10	138	448	137	65.4	507	67.7	103	138	121	138
W/VF 63/130	S2	ME2S	156	447	119	68	517	69.6	129	143	134	143
W/VF 63/130	S2	MX2S	156	491	119	73.1	563	76.9	129	143	134	143
W/VF 63/130	S20	MXN20	158	500.5	146	73.1	571.5	77	129	148	131	148



# W/VF 63/130...P (IEC)

**A**

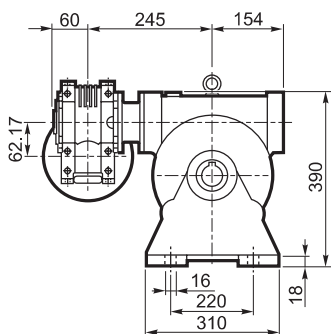

**N**

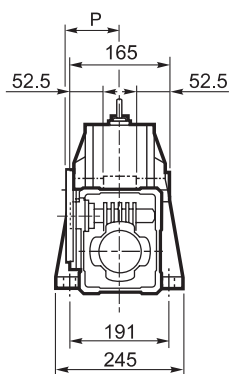

**V**

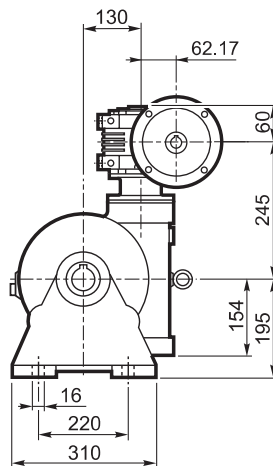
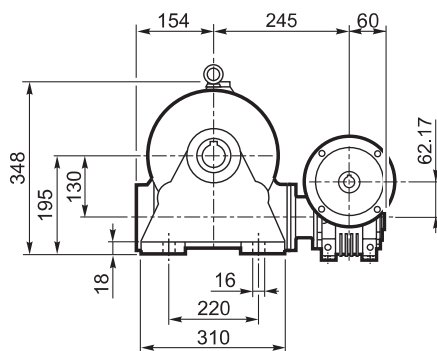
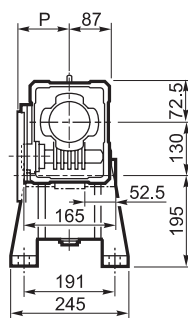
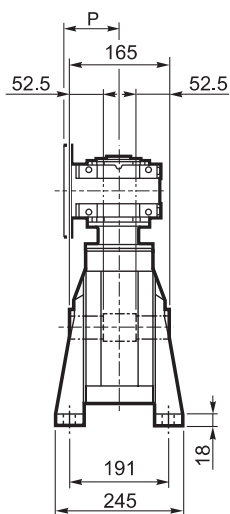

**INPUT**

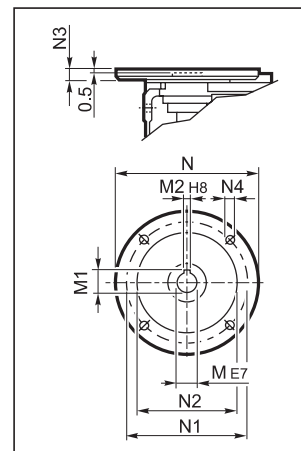

**OUTPUT**

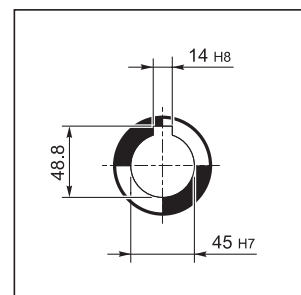





## W/VF 63/130...P (IEC)

**F\_**  
**FC\_**  
**FR\_**

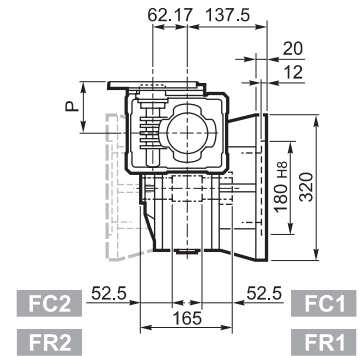
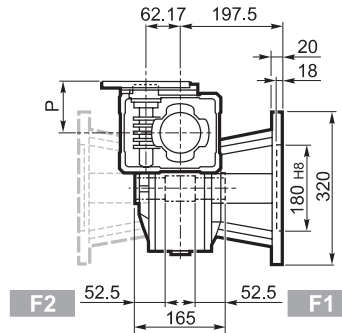
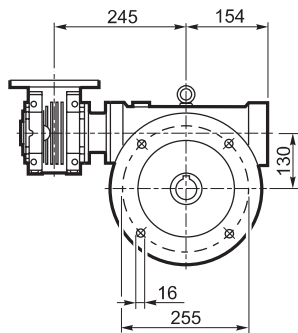

**P\_**

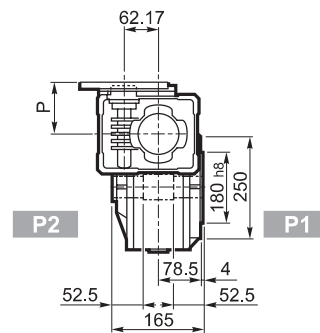
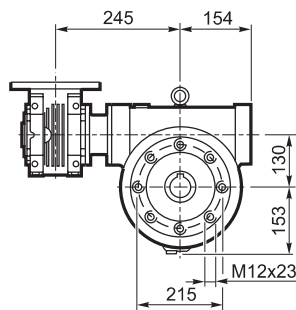

### INPUT

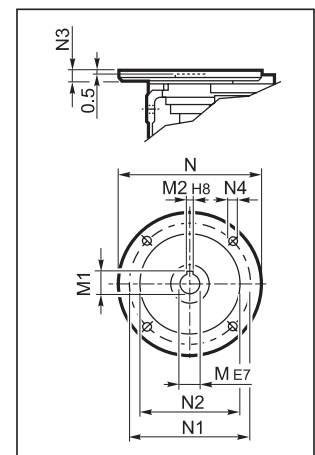

### OUTPUT

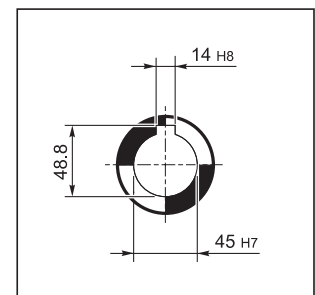

		M	M1	M2	N	N1	N2	N3	N4	P	
W/VF 63/130	P71 B5	14	16.3	5	160	130	110	11	9	95	57
W/VF 63/130	P80 B5	19	21.8	6	200	165	130	12	11.5	102	
W/VF 63/130	P90 B5	24	27.3	8	200	165	130	12	11.5	102	
W/VF 63/130	P71 B14	14	16.3	5	105	85	70	11	6.5	95	
W/VF 63/130	P80 B14	19	21.8	6	120	100	80	11	6.5	102	
W/VF 63/130	P90 B14	24	27.3	8	140	115	95	11	8.5	102	



# VF 150...P (IEC)

**A**

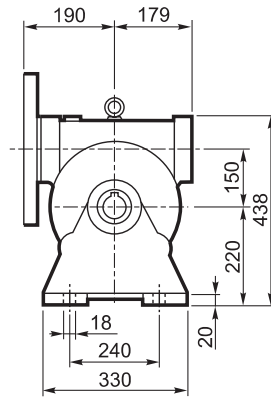
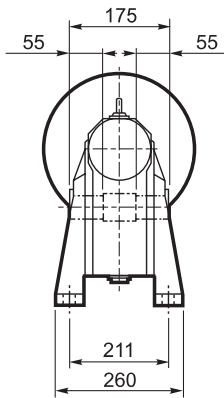

**INPUT**

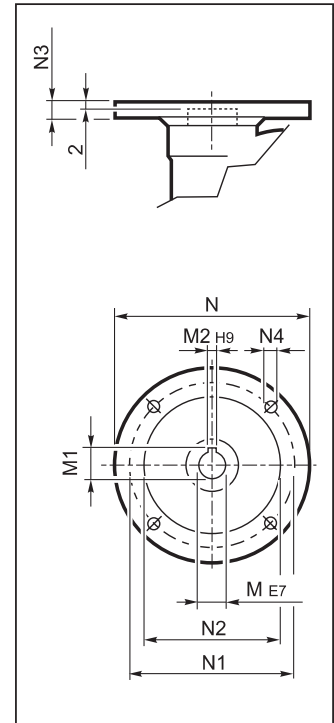

**N**

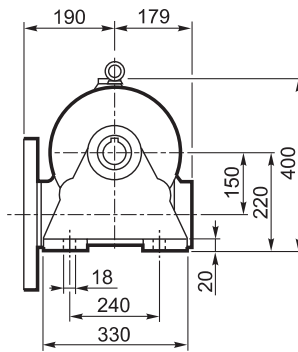
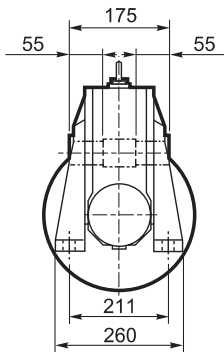

**OUTPUT**

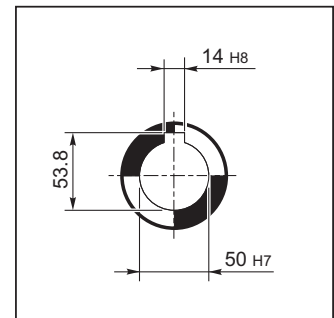

**V**

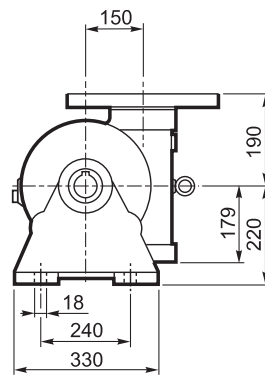
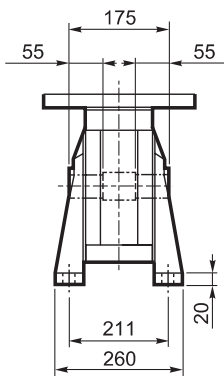



## VF 150...P (IEC)

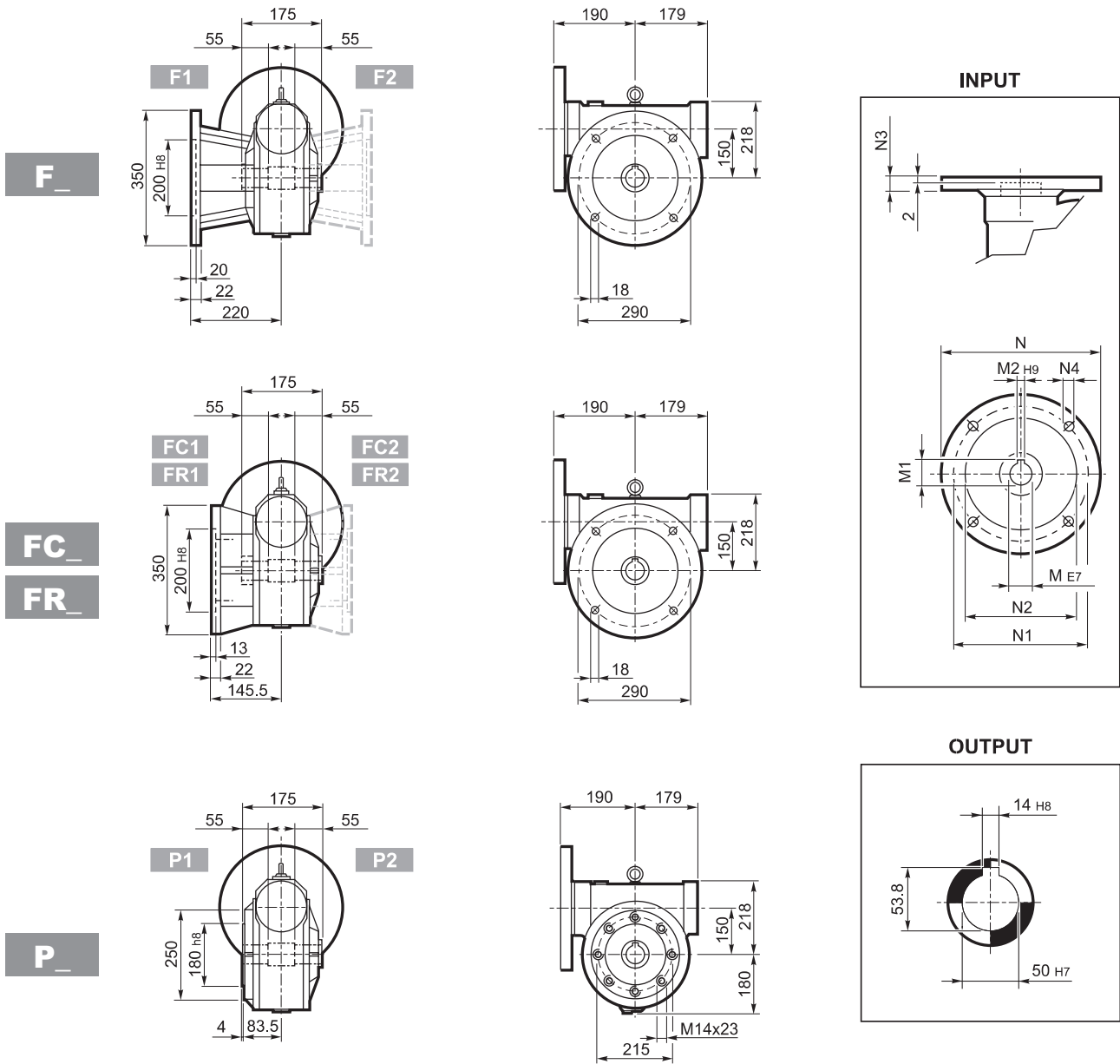

		M	M1	M2	N	N1	N2	N3	N4	
VF 150	P100 B5	28	31.3	8	250	215	180	11	13	60
VF 150	P112 B5	28	31.3	8	250	215	180	11	13	
VF 150	P132 B5	38	41.3	10	300	265	230	16	13	
VF 150	P160 B5	42	44.6#	12	350	300	250	18	18	

# Linguetta ribassata



# VFR 150...P (IEC)

**A**

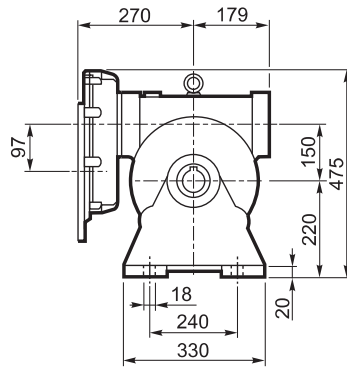
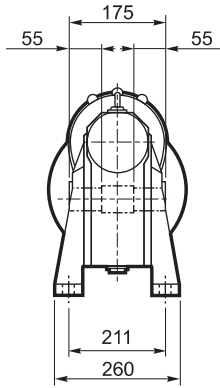

**INPUT**

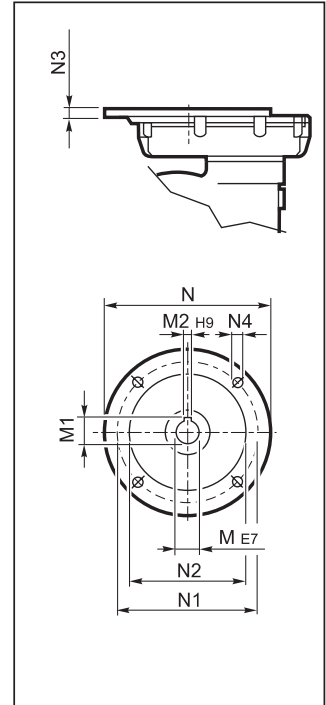

**N**

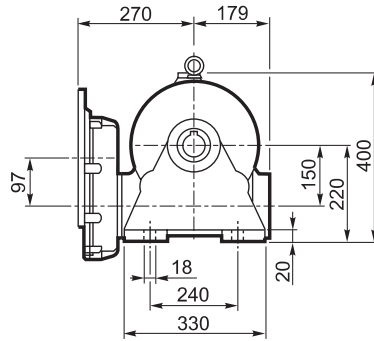
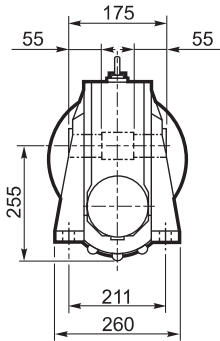

**OUTPUT**

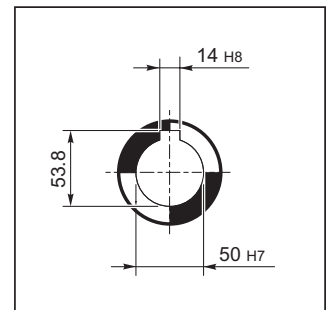

**V**

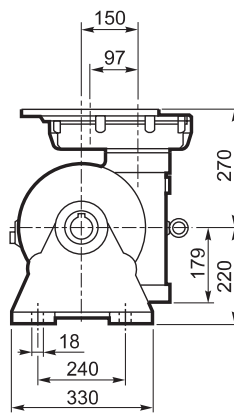
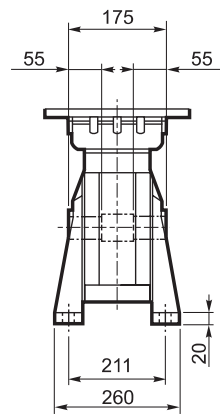



## VFR 150...P (IEC)

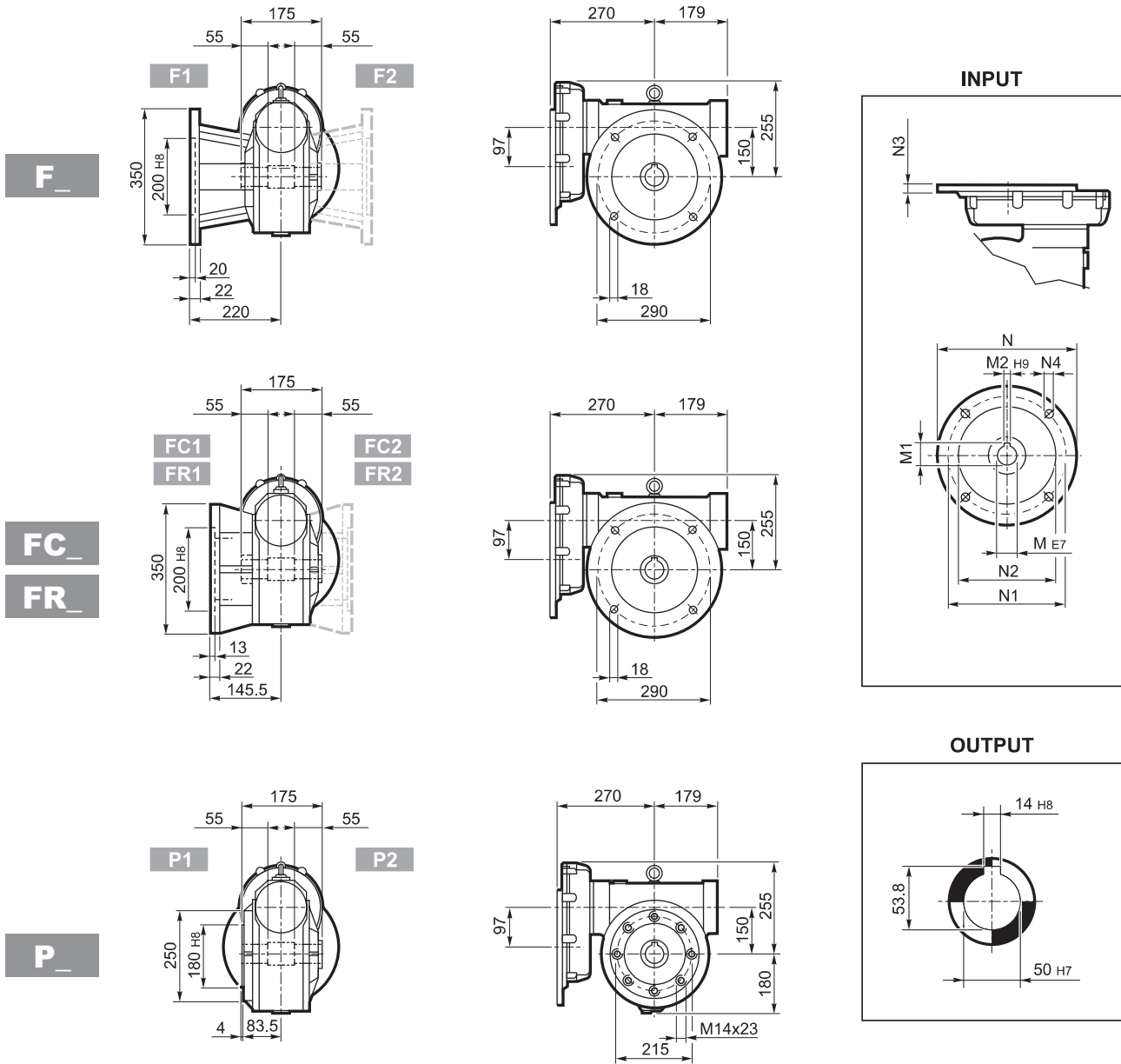

		M	M1	M2	N	N1	N2	N3	N4	
VFR 150	P90 B5	24 K6	27.3	8	200	165	130	13	M10x25	71
VRF 150	P100 B5	28 K6	31.3	8	250	215	180	13	M12x35	
VRF 150	P112 B5	28 J6	31.3	8	250	215	180	13	M12x35	
VFR 150	P132 B5	38 J6	39.6#	10	300	265	230	13	M12x35	

# Linguetta ribassata



# W/VF 86/150...M/ME/MX/MXN

**A**

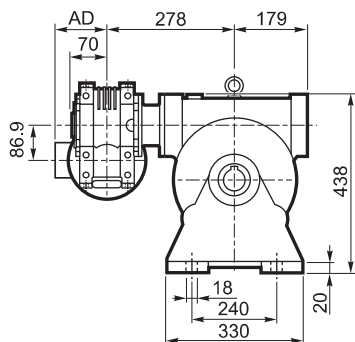

**OUTPUT**

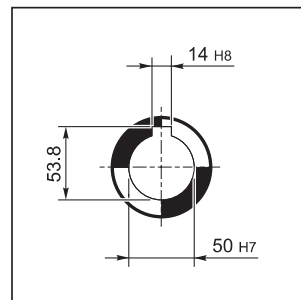

**N**

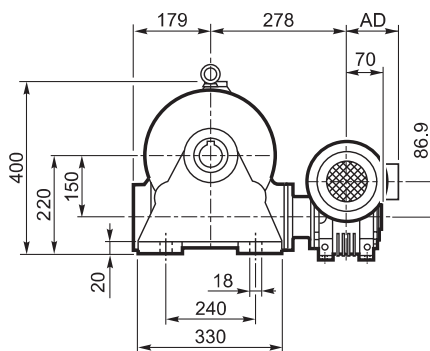
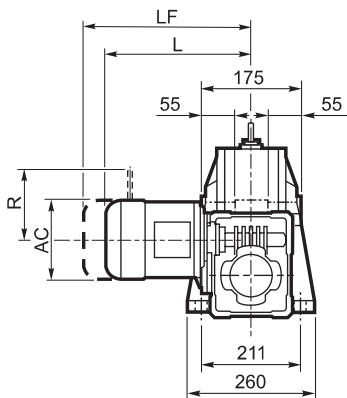

**V**

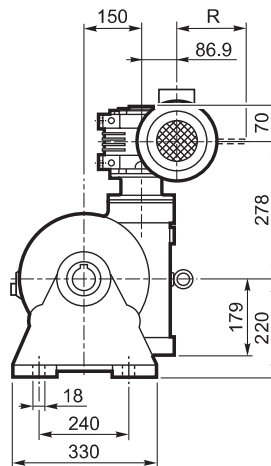
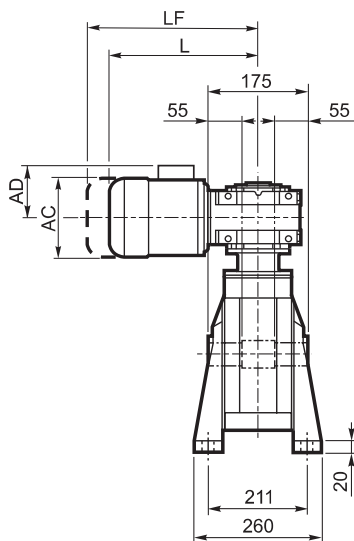



## W/VF 86/150...M/ME/MX/MXN

**F\_**  
**FC\_**  
**FR\_**

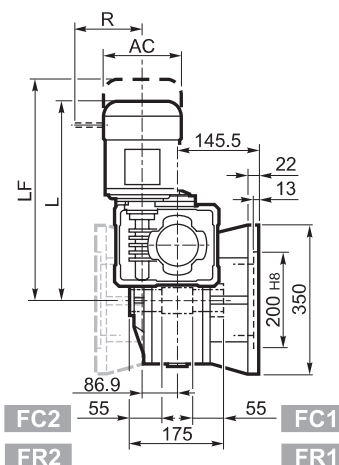
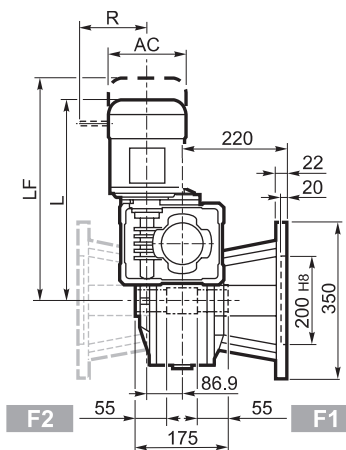
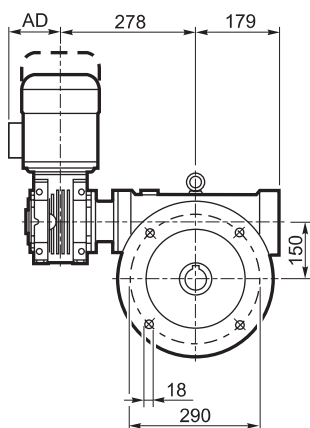

**P\_**

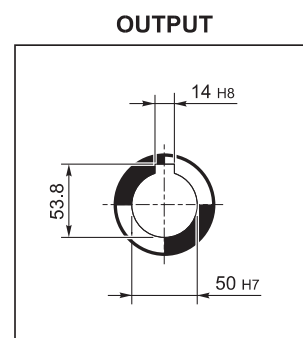
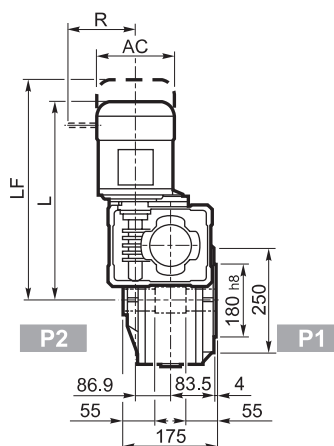
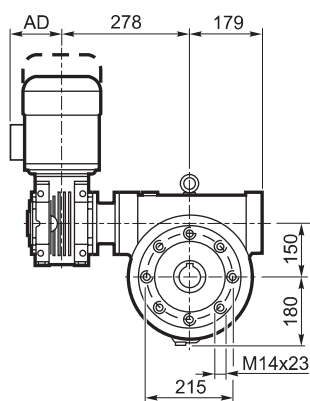

			M/ME/MX/MXN				M...FD M...FA		M...FD		M...FA	
			AC	L	AD	Kg	LF	Kg	R	AD	R	AD
W/VF 86/150	S1	M1	138	474	108	82	385	84	103	135	124	108
W/VF 86/150	S1	ME1	138	474	108	82	534	84	103	135	124	135
W/VF 86/150	S10	MXN10	138	503	137	84.4	562	86.8	103	138	121	138
W/VF 86/150	S2	ME2S	156	499	119	86	569	87.6	129	143	134	143
W/VF 86/150	S2	MX2S	156	543	119	91.1	615	94.9	129	143	134	143
W/VF 86/150	S20	MXN20	158	596.5	146	91.1	667.5	95	129	148	131	148
W/VF 86/150	S3	ME3S	195	542	142	92.5	638	98.5	160	155	160	155
W/VF 86/150	S3	MX3S	195	574	142	95.5	664	102.5	160	155	160	155
W/VF 86/150	S3	ME3L	195	574	142	98	665	104	160	155	160	155
W/VF 86/150	S3	MX3L	195	618	142	104	710	111	160	155	160	155



# W/VF 86/150...P (IEC)

**A**

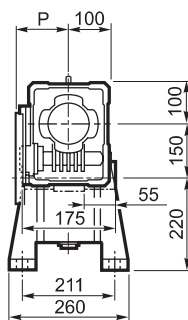
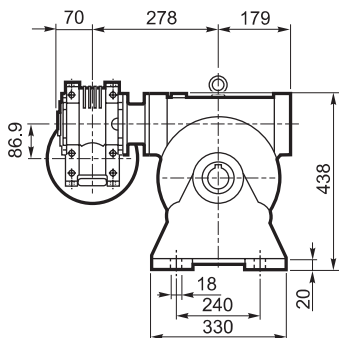

**INPUT**

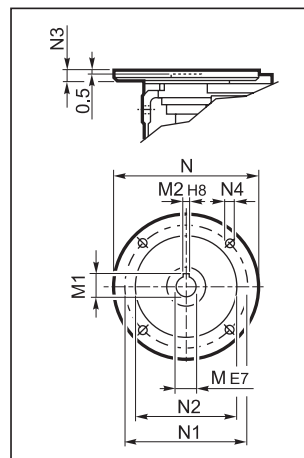

**N**

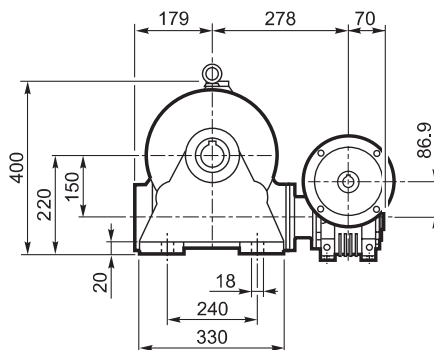
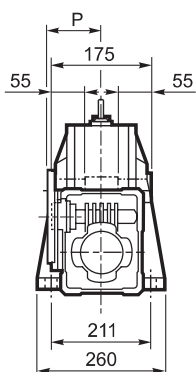

**OUTPUT**

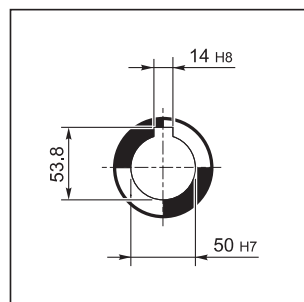

**V**

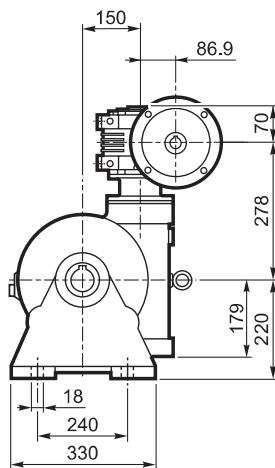
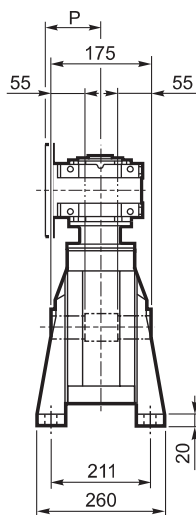





## W/VF 86/150...P (IEC)

**F**  
**FC**  
**FR**

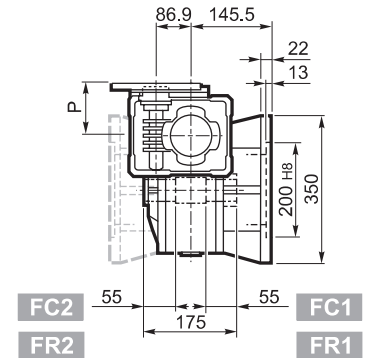
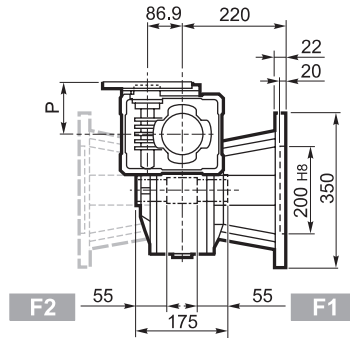
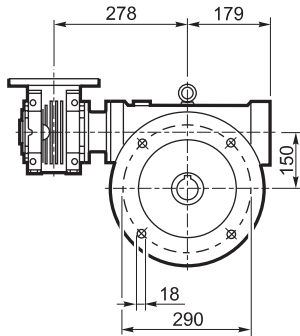

**P**

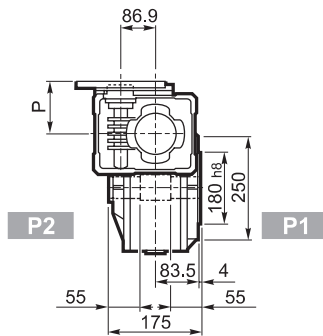
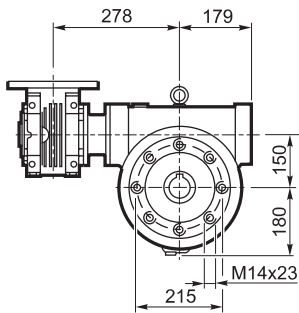

### INPUT

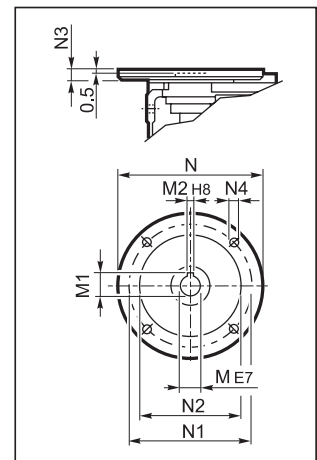

### OUTPUT

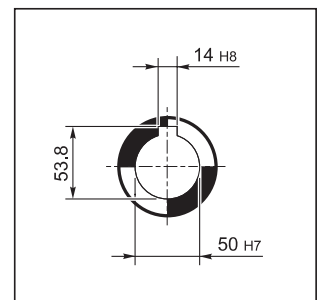

		M	M1	M2	N	N1	N2	N3	N4	P	
W/VF 86/150	P71 B5	14	16.3	5	160	130	110	11	9	128	75
W/VF 86/150	P80 B5	19	21.8	6	200	165	130	12	11.5	128	
W/VF 86/150	P90 B5	24	27.3	8	200	165	130	12	11.5	128	
W/VF 86/150	P100 B5	28	31.3	8	250	215	180	13	12.5	136	
W/VF 86/150	P112 B5	28	31.3	8	250	215	180	13	12.5	136	
W/VF 86/150	P80 B14	19	21.8	6	120	100	80	7.5	6.5	128	
W/VF 86/150	P90 B14	24	27.3	8	140	115	95	7.5	8.5	128	
W/VF 86/150	P100 B14	28	31.3	8	160	130	110	10	8.5	136	
W/VF 86/150	P112 B14	28	31.3	8	160	130	110	10	8.5	136	



# VF 185...P (IEC)

**A**

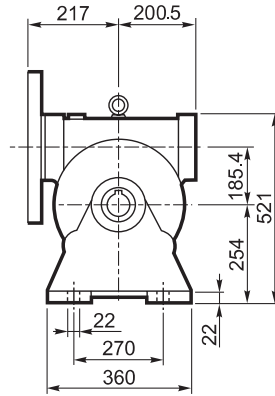
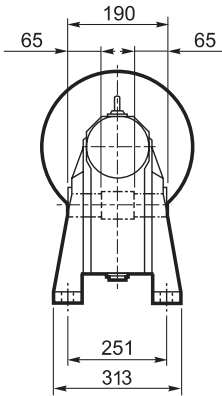

**N**

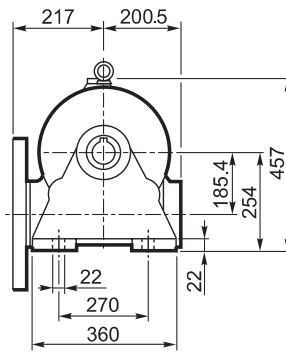
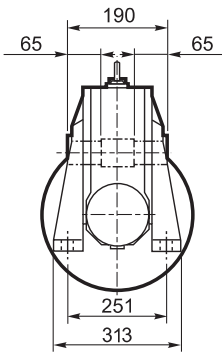

**V**

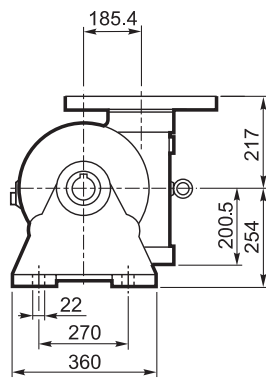
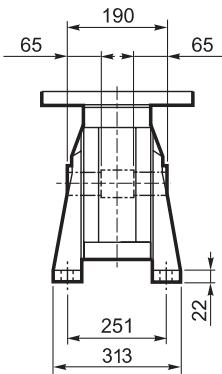

**INPUT**

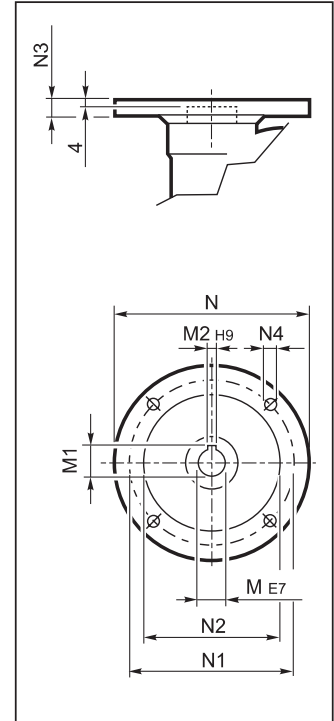

**OUTPUT**

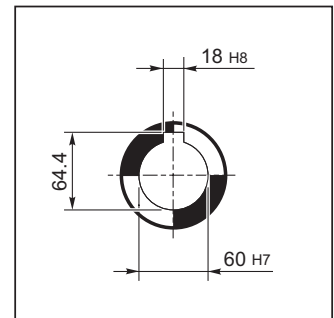



## VF 185...P (IEC)

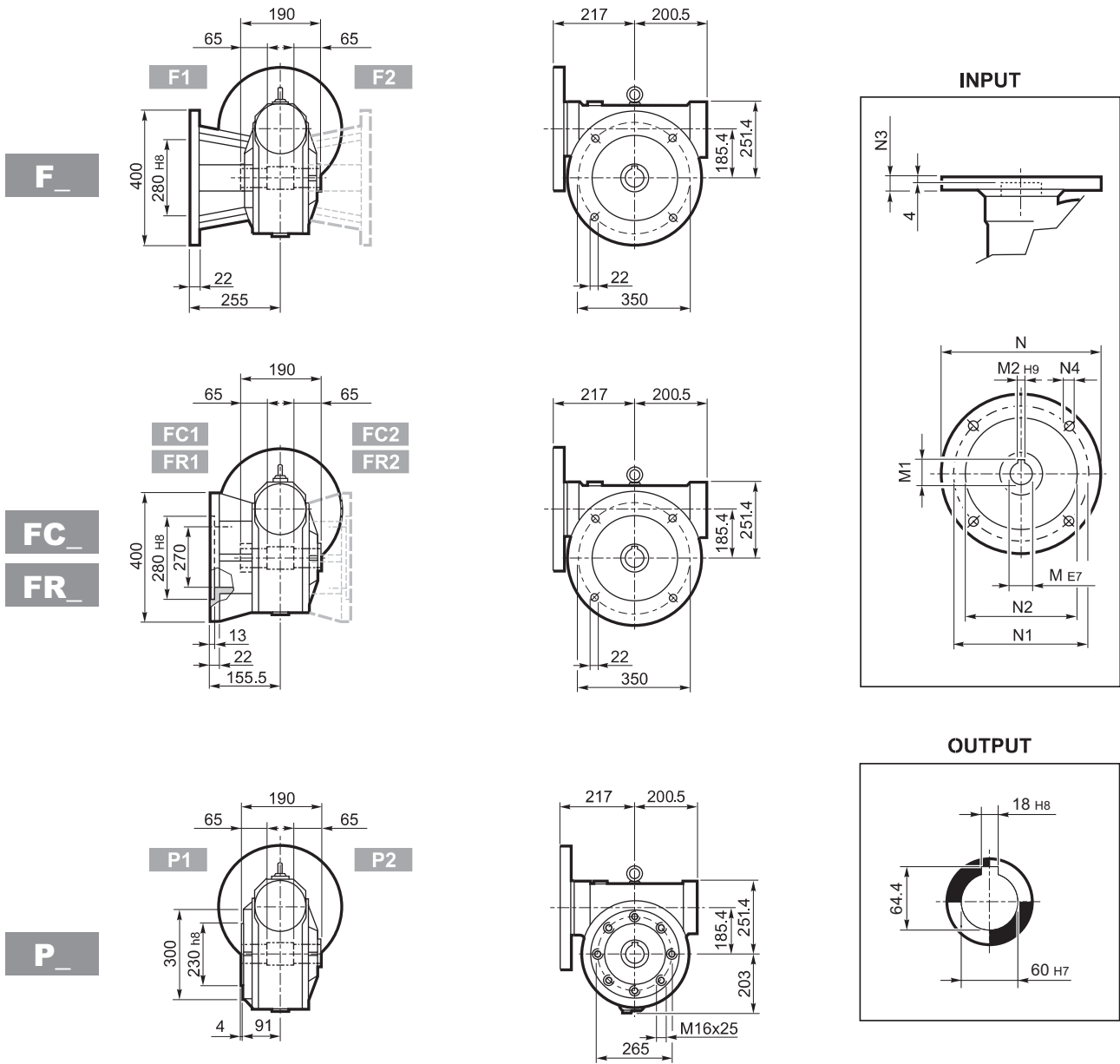

		M	M1	M2	N	N1	N2	N3	N4	
VF 185	P100 B5	28	31.3	8	250	215	180	16	13	94
VF 185	P112 B5	28	31.3	8	250	215	180	16	13	
VF 185	P132 B5	38	41.3	10	300	265	230	16	13	
VF 185	P160 B5	42	45.3	12	350	300	250	18	18	
VF 185	P180 B5	48	51.2#	14	350	300	250	18	18	

# Linguetta ribassata



# VFR 185...P (IEC)

**A**

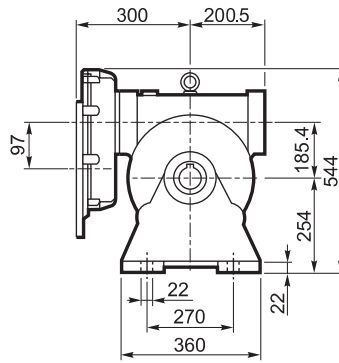
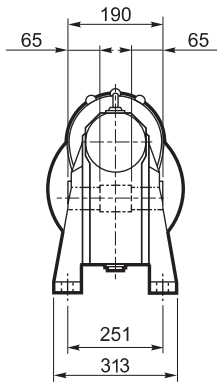

**INPUT**

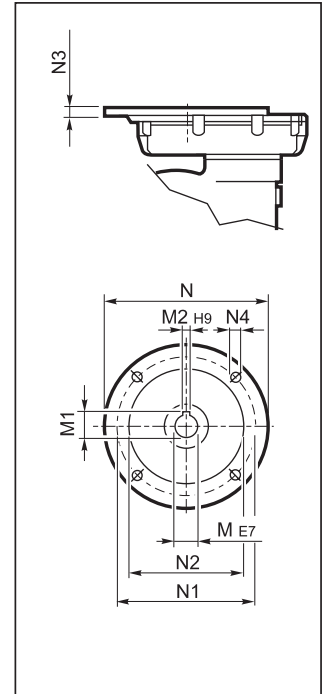

**N**

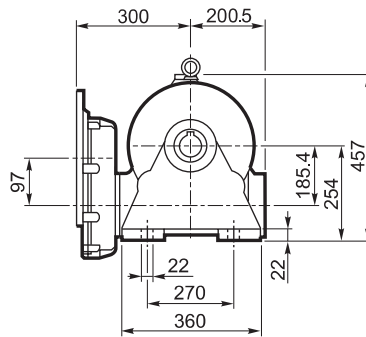
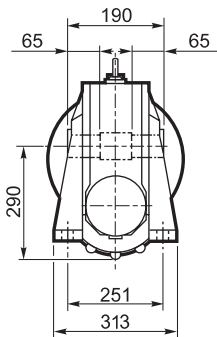

**OUTPUT**

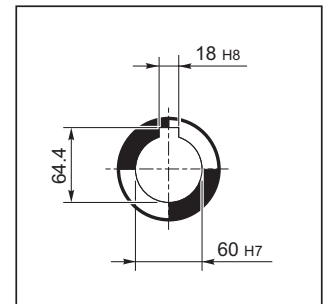



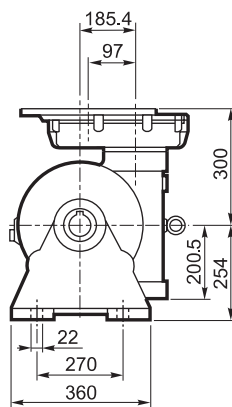
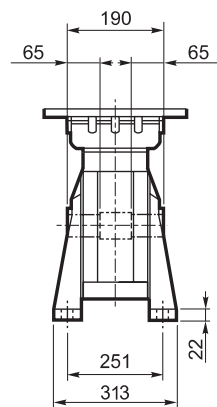

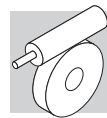
**V**



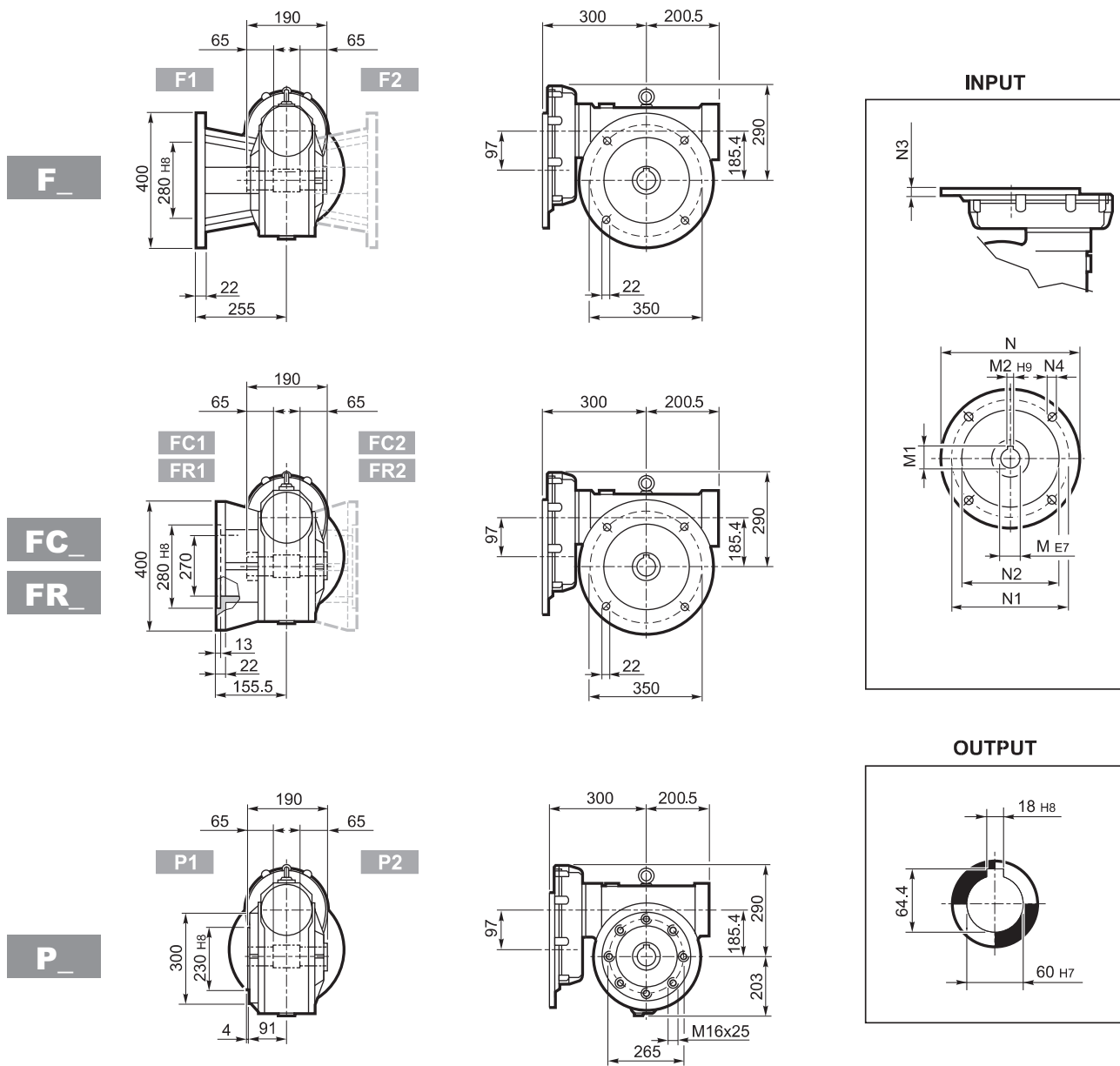

## VFR 185...P (IEC)



		M	M1	M2	N	N1	N2	N3	N4	
VFR 185	P90 B5	24 K6	27.3	8	200	165	130	13	M10x25	110
VRF 185	P100 B5	28 K6	31.3	8	250	215	180	13	M12x35	
VRF 185	P112 B5	28 K6	31.3	8	250	215	180	13	M12x35	
VFR 185	P132 B5	38 J6	39.6#	10	300	265	230	13	M12x35	

# Linguetta ribassata



# W/VF 86/185...M/ME/MX/MXN

**A**

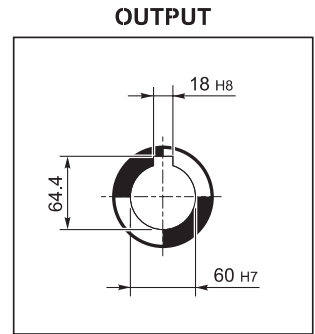
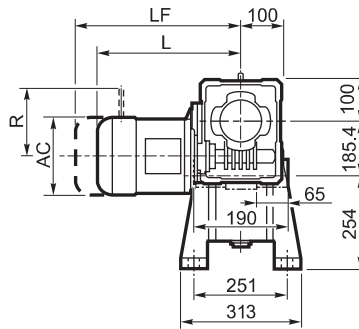
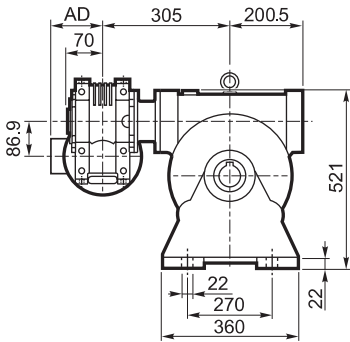

**N**

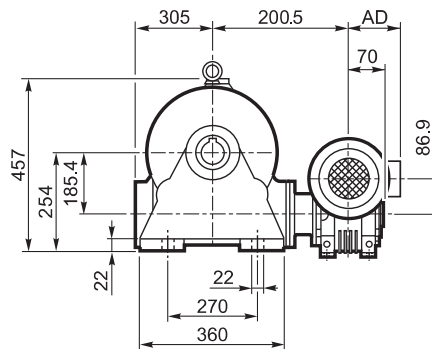
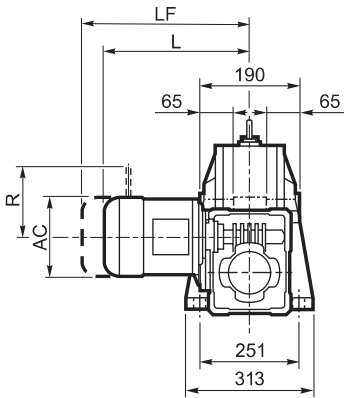

**V**

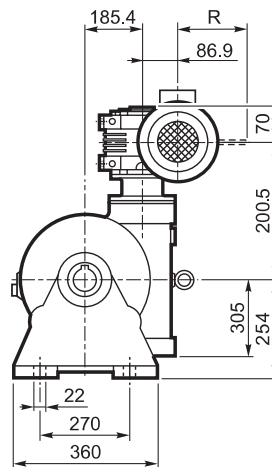
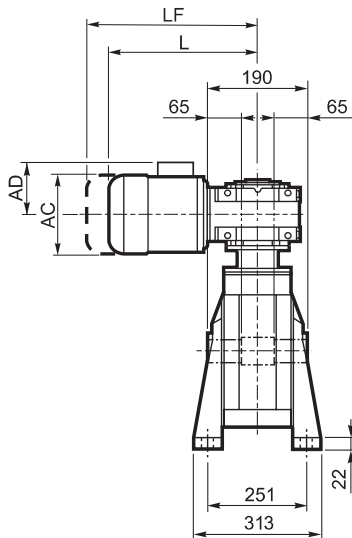



## W/VF 86/185...M/ME/MX/MXN

**F\_**  
**FC\_**  
**FR\_**

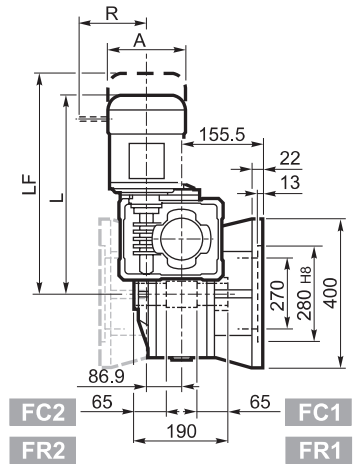
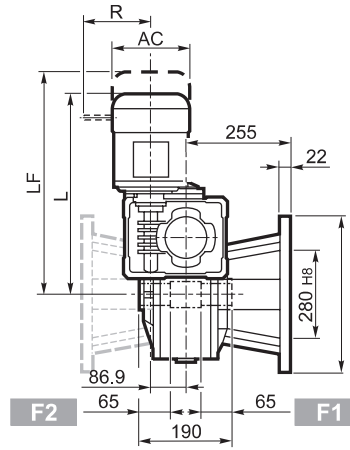
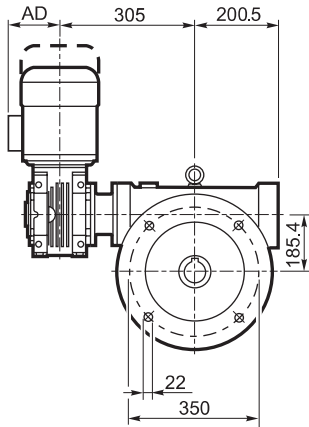

**P\_**

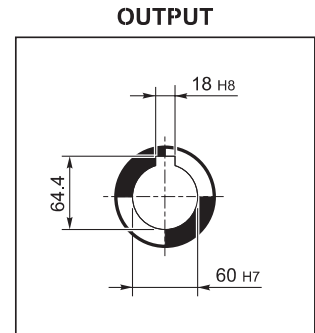
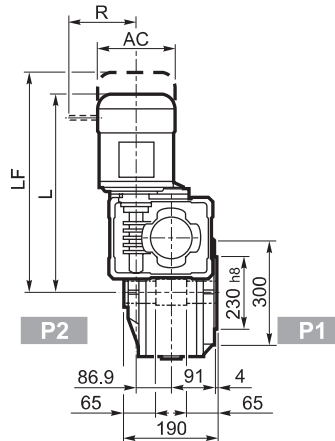
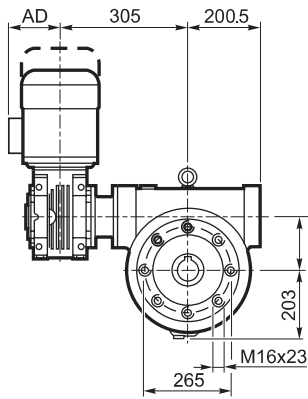

			M/ME/MX/MXN				M...FD M...FA		M...FD		M...FA	
			AC	L	AD	Kg	LF	Kg	R	AD	R	AD
W/VF 86/185	S1	M1	138	509	108	116	570	118	103	135	124	108
W/VF 86/185	S1	ME1	138	509	108	116	599	118	103	135	124	135
W/VF 86/185	S10	MXN10	138	538	137	118.4	597	120.8	103	138	121	138
W/VF 86/185	S2	ME2S	156	534	119	120	604	121.6	129	143	134	143
W/VF 86/185	S2	MX2S	156	578	119	125.1	650	128.9	129	143	134	143
W/VF 86/185	S20	MXN20	158	631.5	146	125.1	702.5	127.3	129	148	131	148
W/VF 86/185	S3	ME3S	195	577	142	126.5	673	132.5	160	155	160	155
W/VF 86/185	S3	MX3S	195	609	142	129.5	699	136.5	160	155	160	155
W/VF 86/185	S3	ME3L	195	609	142	132	700	138	160	155	160	155
W/VF 86/185	S3	MX3L	195	653	142	138	745	145	160	155	160	155



# W/VF 86/185...P (IEC)

**A**

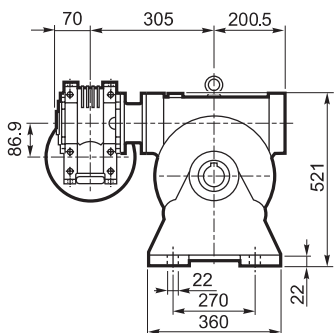

**N**

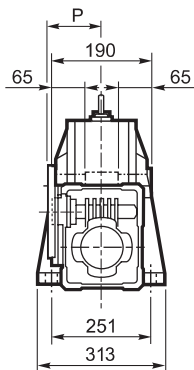

**V**

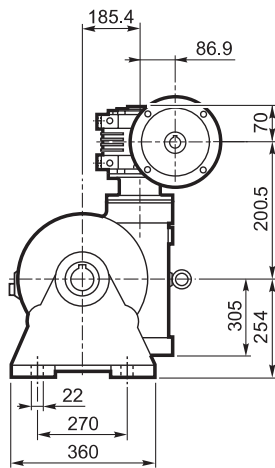
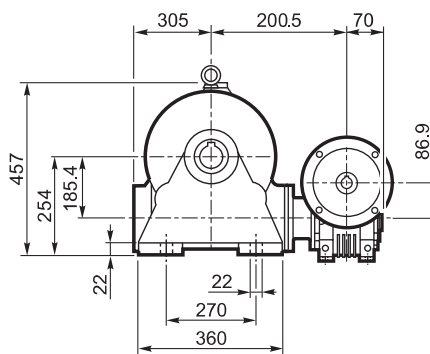
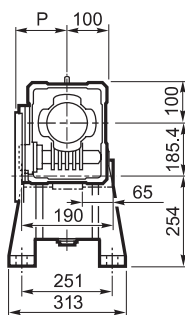
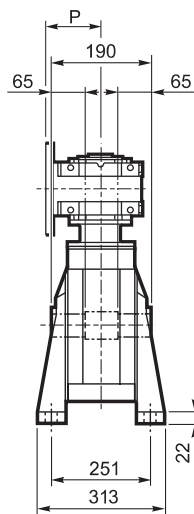

**INPUT**

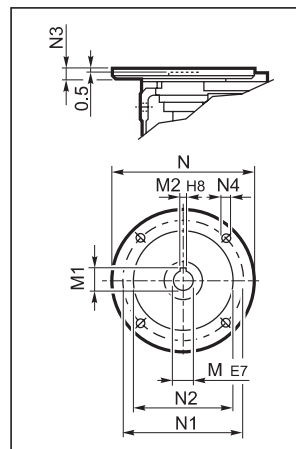

**OUTPUT**

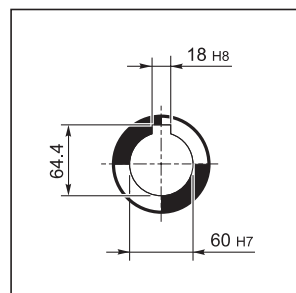





## W/VF 86/185...P (IEC)

**F\_**  
**FC\_**  
**FR\_**

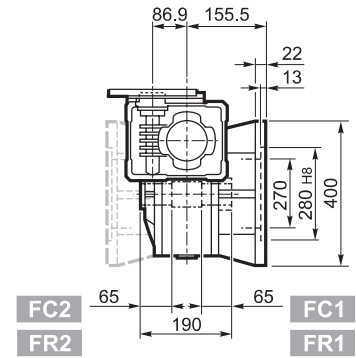
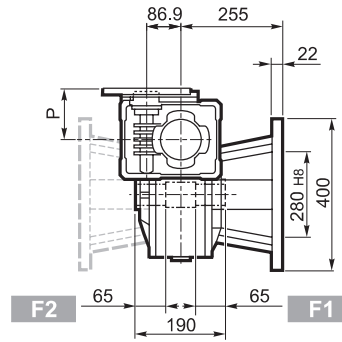
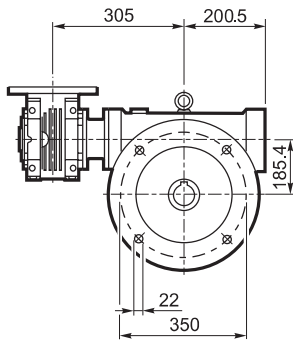

**P\_**

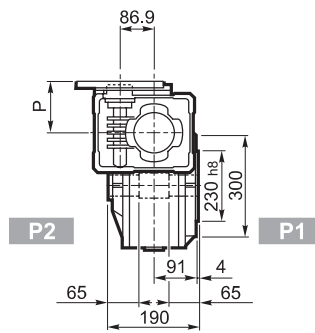
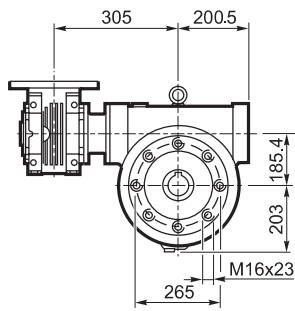

### INPUT

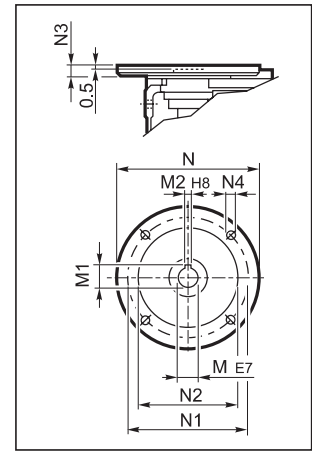

### OUTPUT

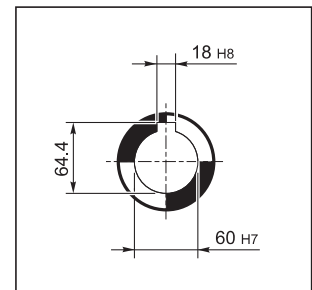

		M	M1	M2	N	N1	N2	N3	N4	P	
W/VF 86/185	P71 B5	14	16.3	5	160	130	110	11	9	128	109
W/VF 86/185	P80 B5	19	21.8	6	200	165	130	12	11.5	128	
W/VF 86/185	P90 B5	24	27.3	8	200	165	130	12	11.5	128	
W/VF 86/185	P100 B5	28	31.3	8	250	215	180	13	12.5	136	
W/VF 86/185	P112 B5	28	31.3	8	250	215	180	13	12.5	136	
W/VF 86/185	P80 B14	19	21.8	6	120	100	80	7.5	6.5	128	
W/VF 86/185	P90 B14	24	27.3	8	140	115	95	7.5	8.5	128	
W/VF 86/185	P100 B14	28	31.3	8	160	130	110	10	8.5	136	
W/VF 86/185	P112 B14	28	31.3	8	160	130	110	10	8.5	136	

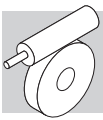

# VF 210...P (IEC)

**A**

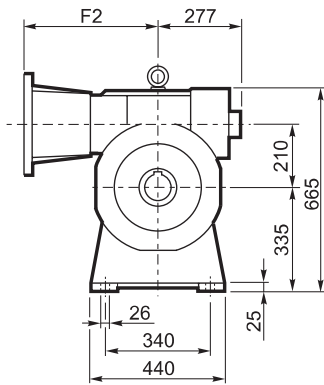
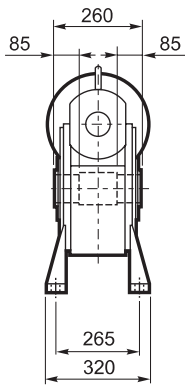

**N**

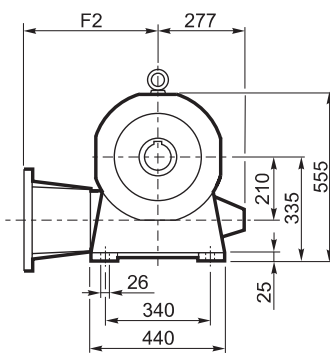
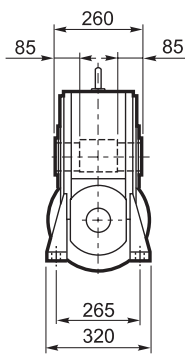

## INPUT

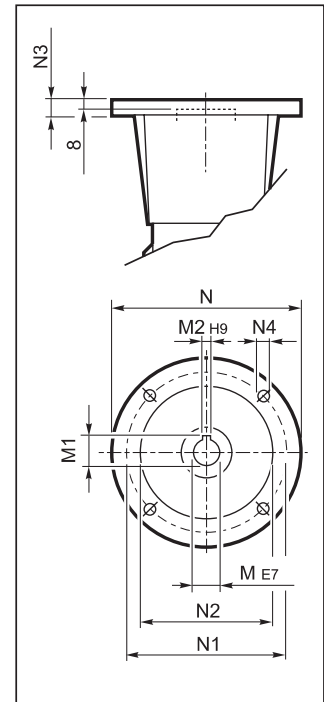

## OUTPUT

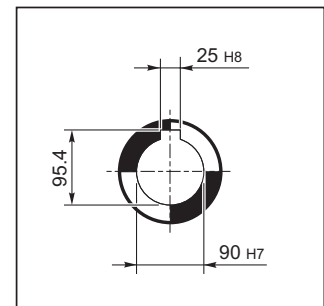



## VF 210...P (IEC)

V

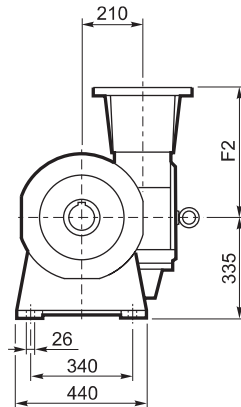
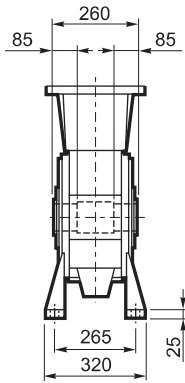

P

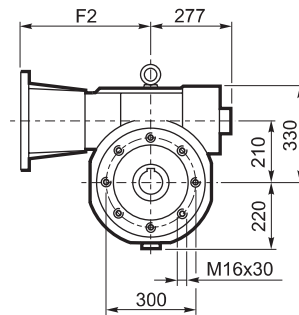
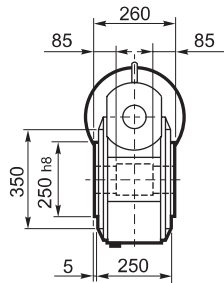

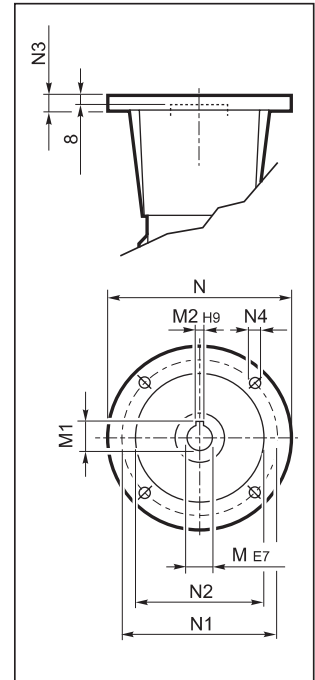

INPUT

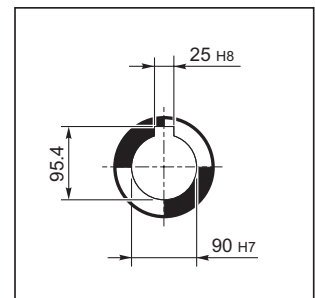

OUTPUT



Nelle forme costruttive A e P viene montata la ventola di raffreddamento.  
Nell'esecuzione P(IEC) è prevista di serie la fornitura del giunto completo per attacco motore.

		F2	M	M1	M2	N	N1	N2	N3	N4	
VF 210	P132 B5	485	38	41.3	10	300	265	230	25	M12	210
VF 210	P160 B5	460	42	45.3	12	350	300	250	22	18	
VF 210	P180 B5	460	48	51.8	14	350	300	250	22	18	
VF 210	P200 B5	485	55	59.3	16	400	350	300	25	M16	
VF 210	P225 B5	490	60	64.4	18	450	400	350	22	18 #	

# N° 8 fori a 45°



# VFR 210...P (IEC)

**A**

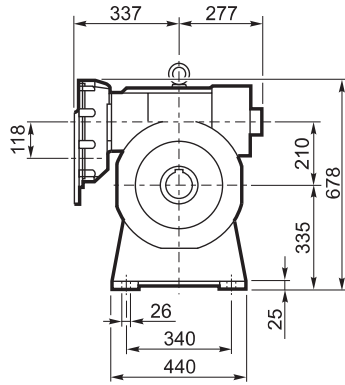
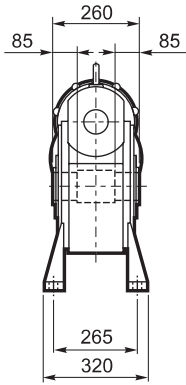

**N**

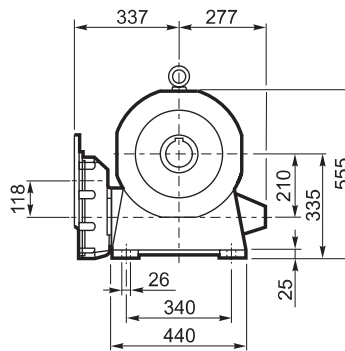
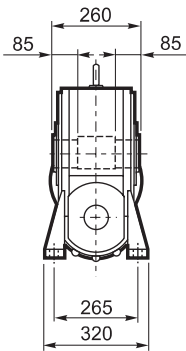

## INPUT

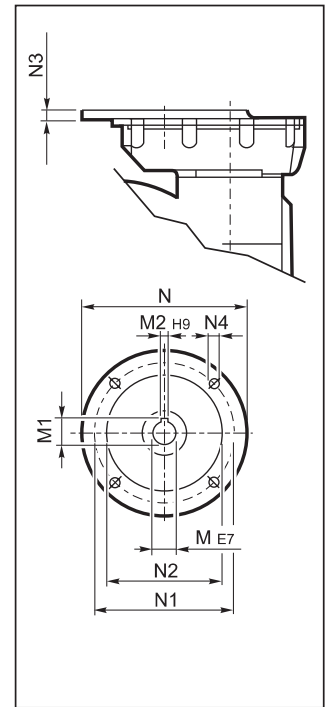

## OUTPUT

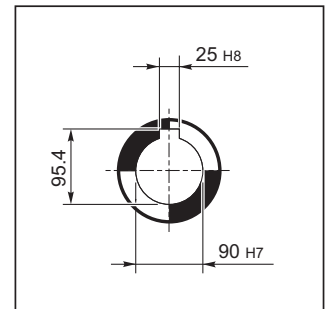



## VFR 210...P (IEC)

**V**

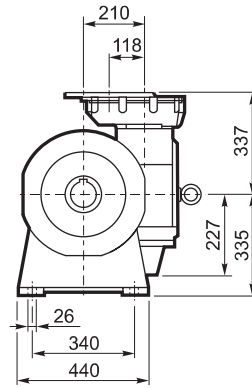
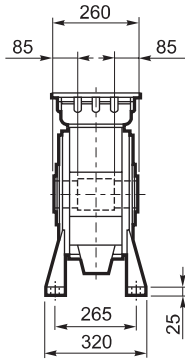

**P**

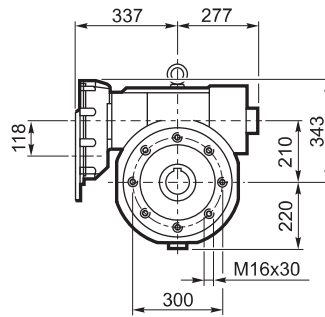
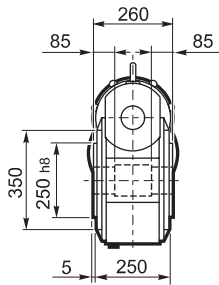

**INPUT**

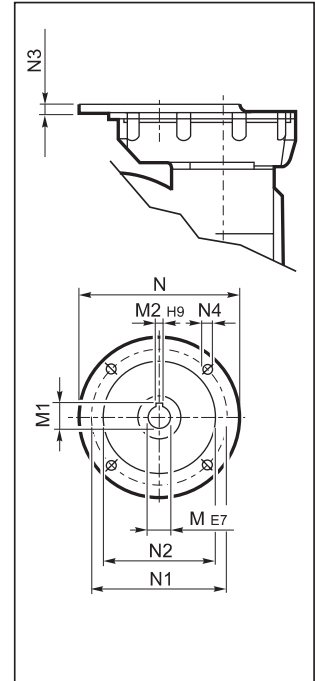

**OUTPUT**

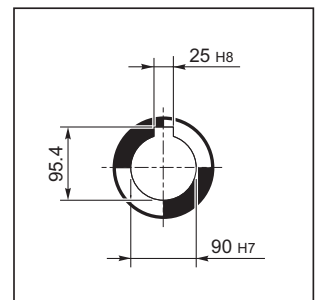

Nelle forme costruttive A e P viene montata la ventola di raffreddamento.

		M	M1	M2	N	N1	N2	N3	N4	
VRF 210	P100 B5	28 K6	31.3	8	250	215	180	13	M12x35	185
VRF 210	P112 B5	28 K6	31.3	8	250	215	180	13	M12x35	
VFR 210	P132 B5	38 J6	41.3	10	300	265	230	13	M12x35	
VFR 210	P160 B5	42 J6	44.3#	12	350	300	250	18	M16x60	

# Linguetta ribassata



## VF/VF 130/210...P (IEC)

**A**

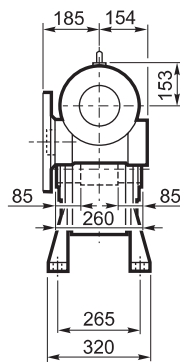
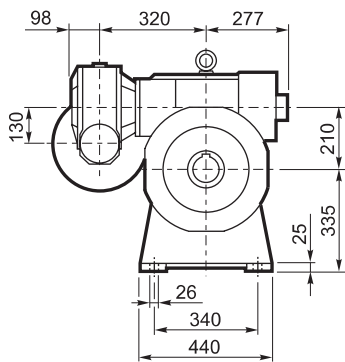

**INPUT**

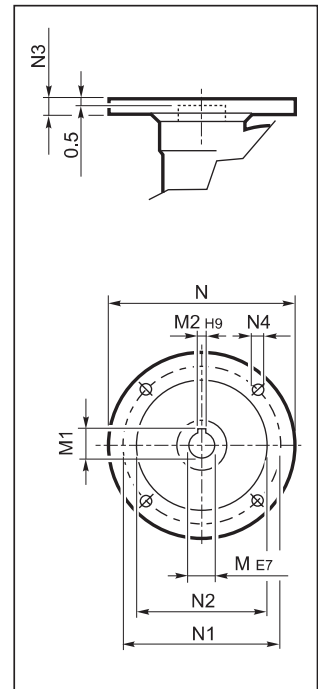

**N**

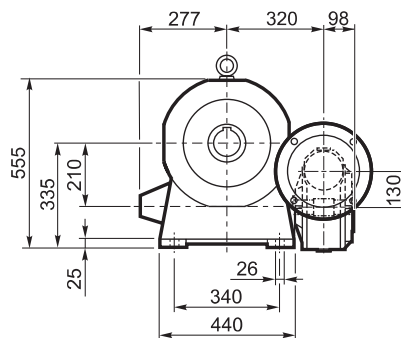
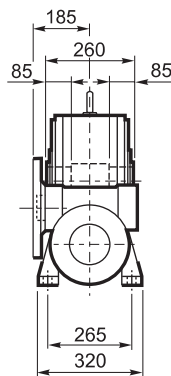

**V**

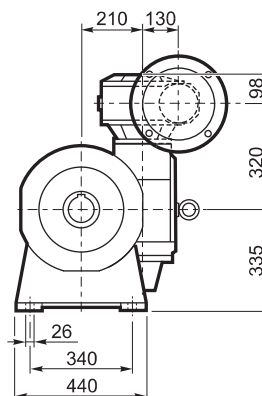
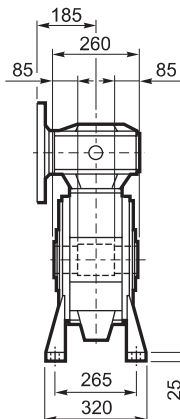

**OUTPUT**

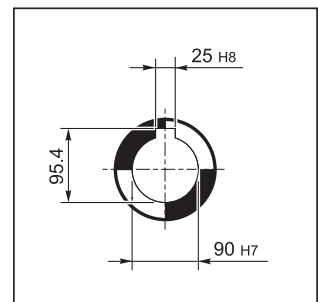

**P**

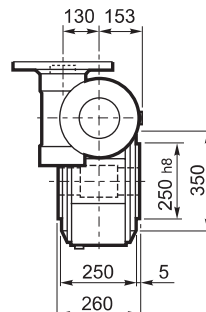
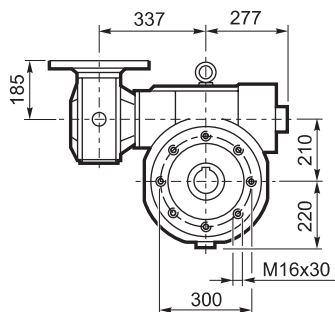

Nelle forme costruttive A e P viene montata la ventola di raffreddamento.

		M	M1	M2	N	N1	N2	N3	N4	
VF/VF 130/210	P90 B5	24	27.3	8	200	165	130	17	11	225
VF/VF 130/210	P100 B5	28	31.3	8	250	215	180	17	13	
VF/VF 130/210	P112 B5	28	31.3	8	250	215	180	17	13	
VF/VF 130/210	P132 B5	38	40.1#	10	300	265	230	17	13	

# Linguetta ribassata

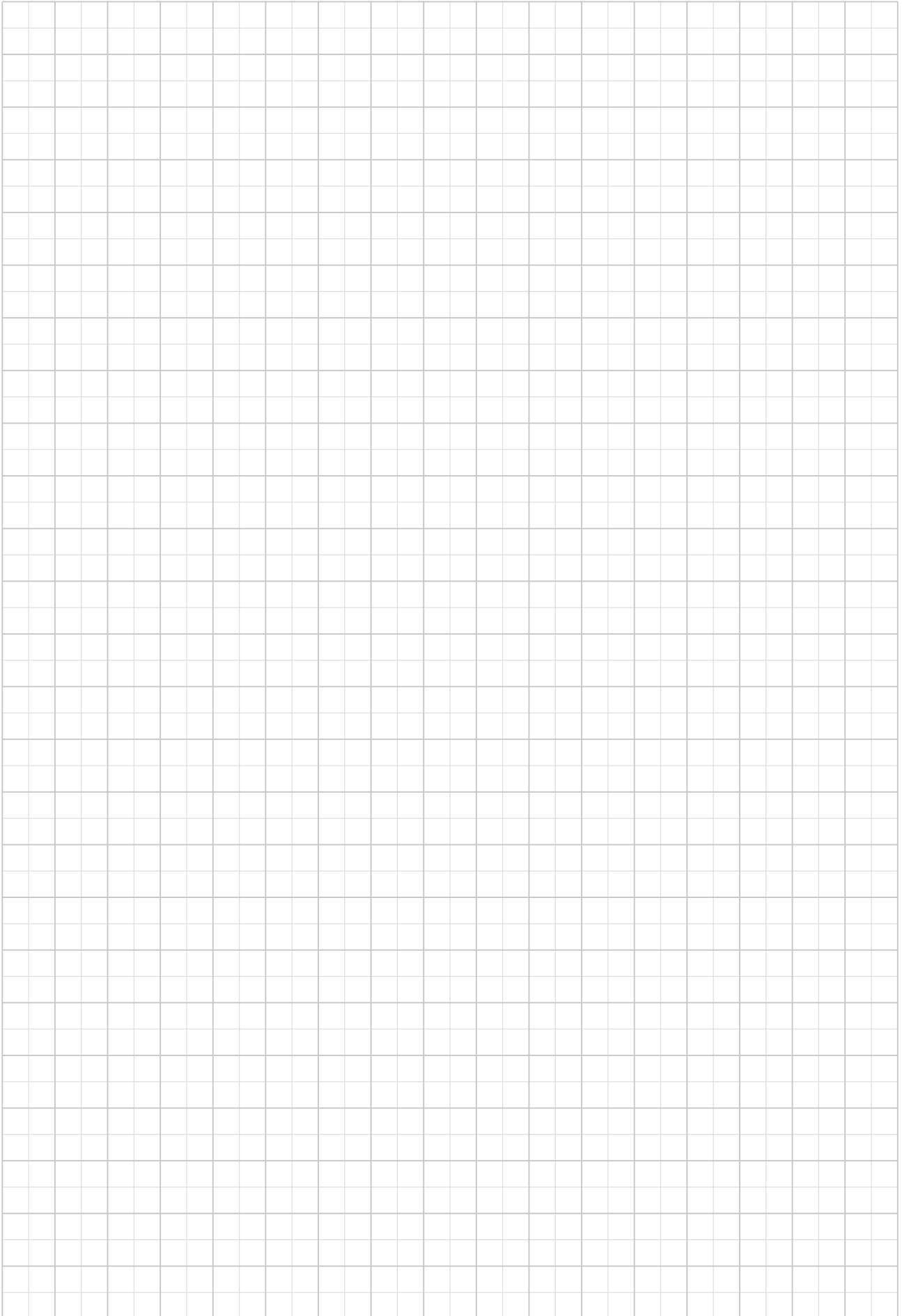
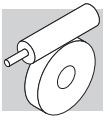



# VF 250...P (IEC)

**A**

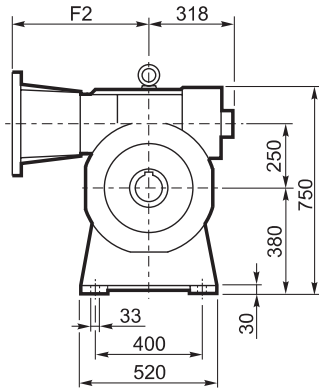
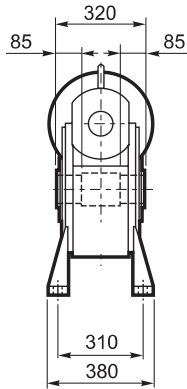

**N**

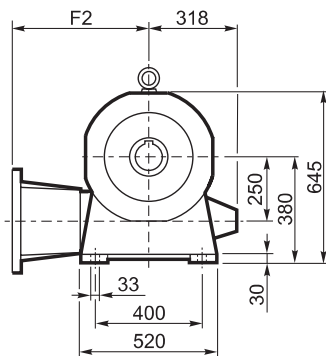
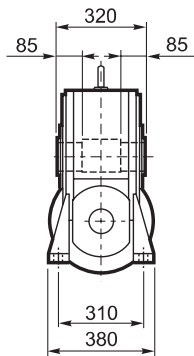

## INPUT

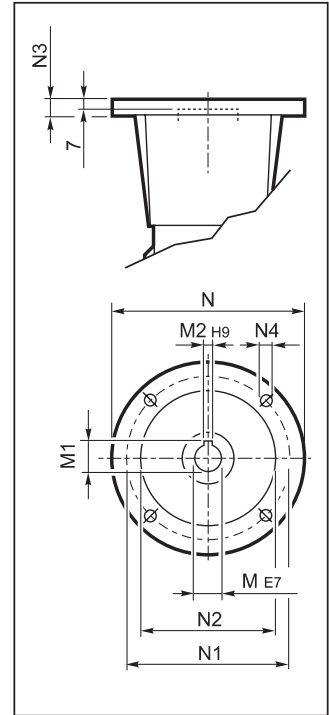

## OUTPUT

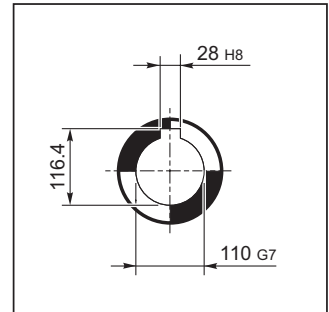





## VF 250...P (IEC)

**V**

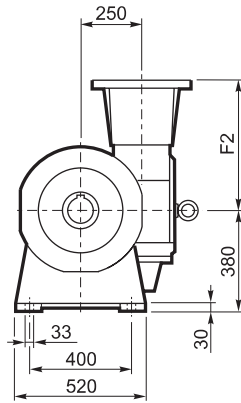
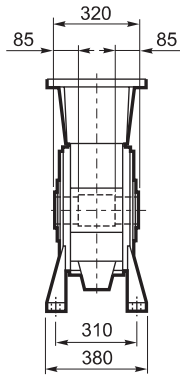

**P**

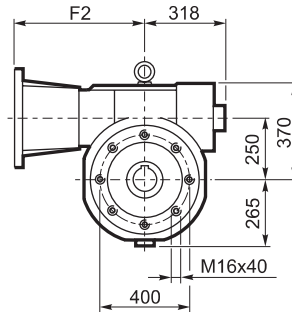
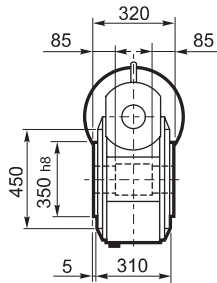

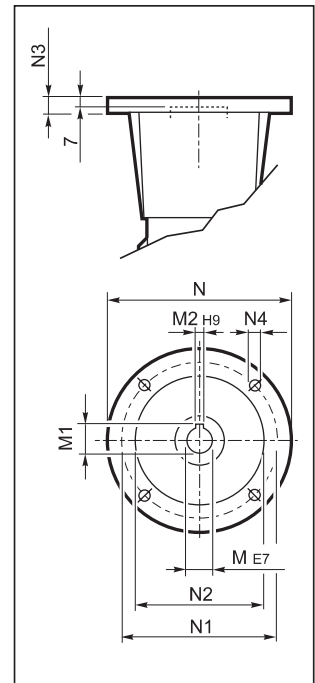

### INPUT

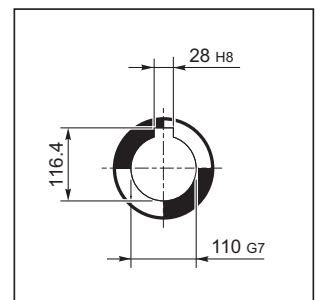

### OUTPUT



Nelle forme costruttive A e P viene montata la ventola di raffreddamento.  
 Nell'esecuzione P(IEC) è prevista di serie la fornitura del giunto completo per attacco motore.

		F2	M	M1	M2	N	N1	N2	N3	N4	
VF 250	P132 B5	531	38	41.3	10	300	265	230	25	M12	310
VF 250	P160 B5	506	42	45.3	12	350	300	250	22	18	
VF 250	P180 B5	506	48	51.8	14	350	300	250	22	18	
VF 250	P200 B5	531	55	59.3	16	400	350	300	25	M16	
VF 250	P225 B5	536	60	64.4	18	450	400	350	22	18#	

# N° 8 fori a 45°



# VFR 250...P (IEC)

**A**

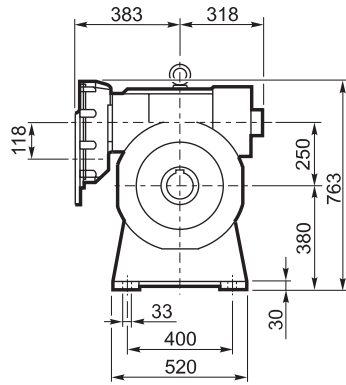
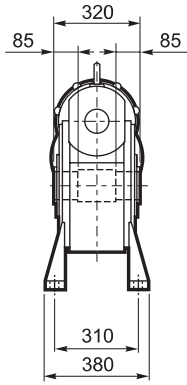

**N**

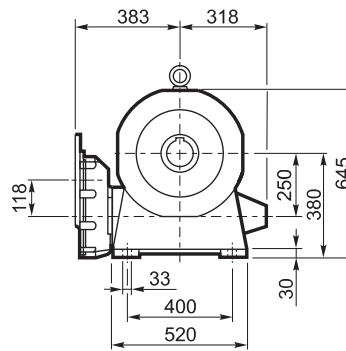
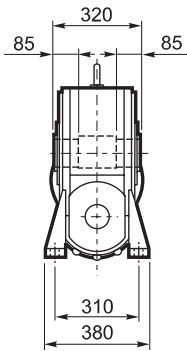

**INPUT**

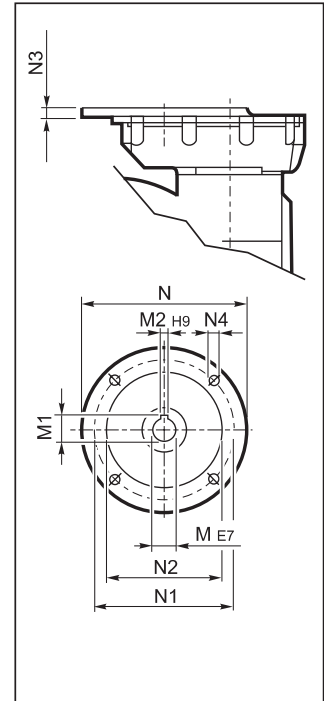

**OUTPUT**

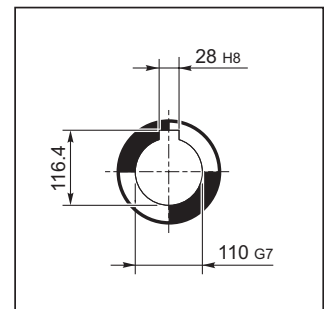



## VFR 250...P (IEC)

**V**

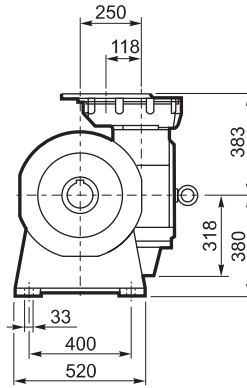
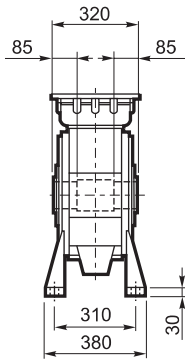

**P**

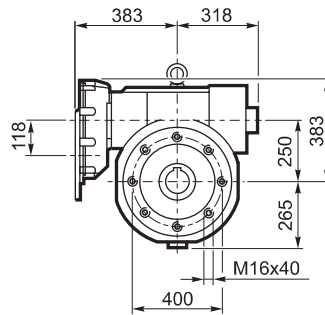
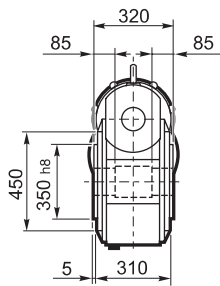

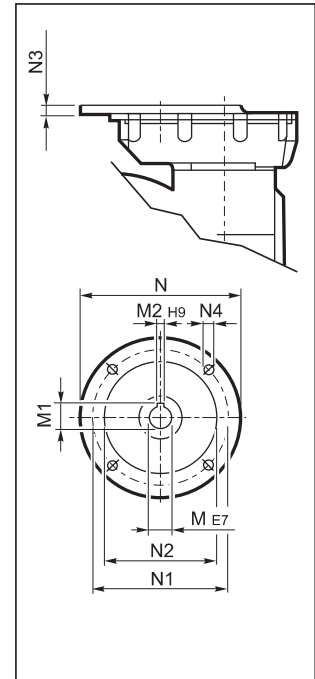

**INPUT**

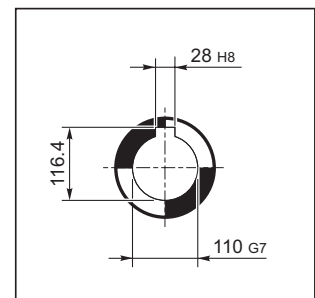

**OUTPUT**



Nelle forme costruttive A e P viene montata la ventola di raffreddamento.

		M	M1	M2	N	N1	N2	N3	N4	
VRF 250	P100 B5	28 K6	31.3	8	250	215	180	13	M12x35	295
VRF 250	P112 B5	28 K6	31.3	8	250	215	180	13	M12x35	
VFR 250	P132 B5	38 J6	41.3	10	300	265	230	13	M12x35	
VFR 250	P160 B5	42 J6	44.3#	12	350	300	250	18	M16x60	

# Linguetta ribassata



## VF/VF 130/250...P (IEC)

**A**

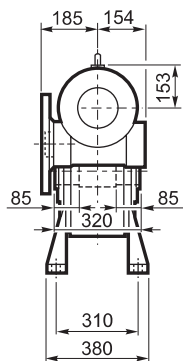
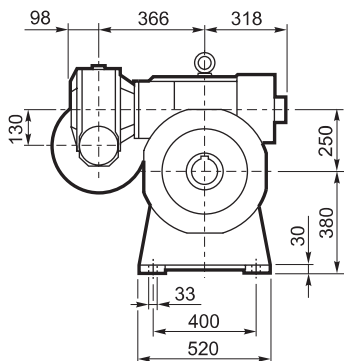

**INPUT**

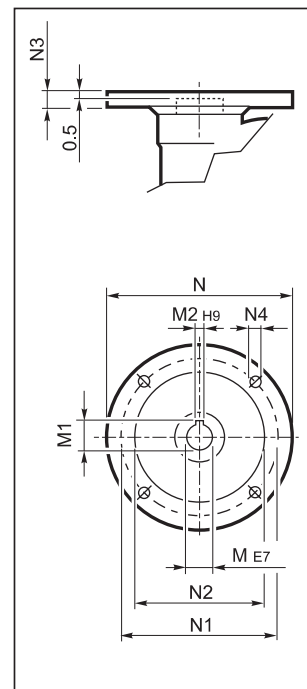

**N**

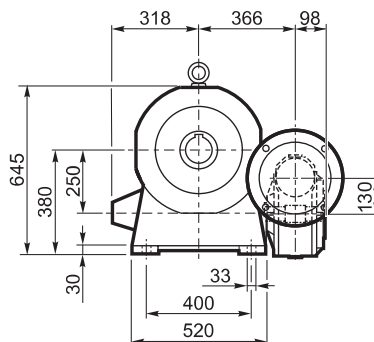
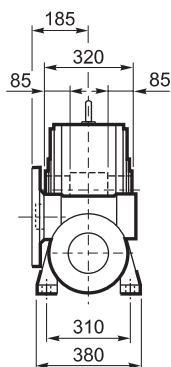

**V**

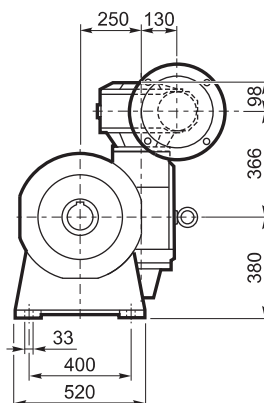
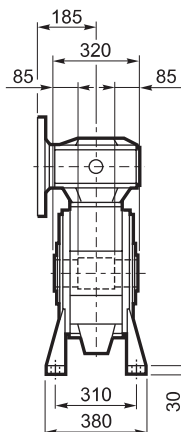

**OUTPUT**

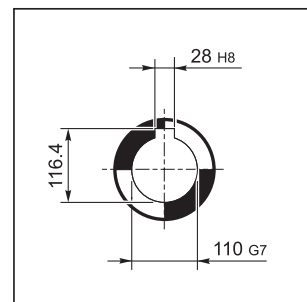

**P**

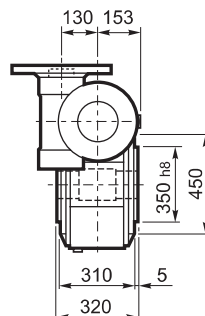
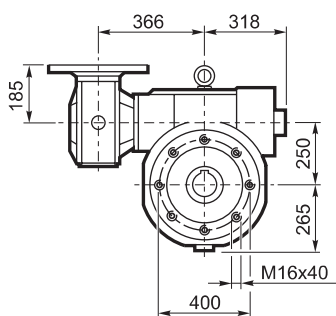

Nelle forme costruttive A e P viene montata la ventola di raffreddamento.

		M	M1	M2	N	N1	N2	N3	N4	
VF/VF 130/250	P 90 B5	24	27.3	8	200	165	130	17	11	325
VF/VF 130/250	P100 B5	28	31.3	8	250	215	180	17	13	
VF/VF 130/250	P112 B5	28	31.3	8	250	215	180	17	13	
VF/VF 130/250	P132 B5	38	40.1#	10	300	265	230	17	13	

# Linguetta ribassata



## 27 DIMENSIONI RIDUTTORI CON INGRESSO HS

### VF 27...HS

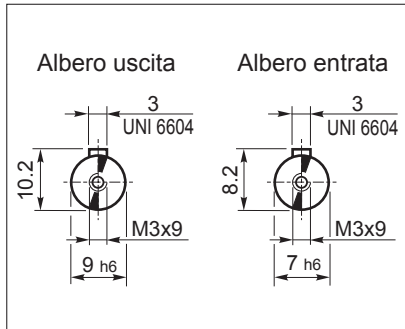

#### VF 27\_A..HS

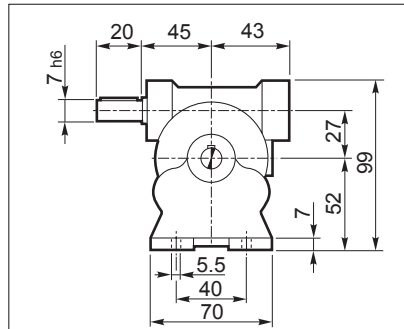

#### VF 27\_N..HS

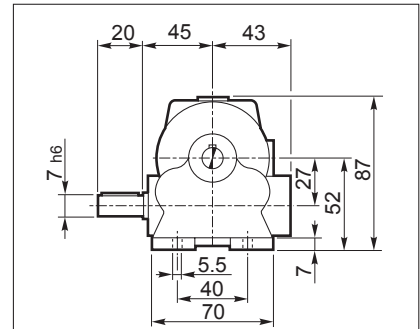

#### VF 27\_V..HS

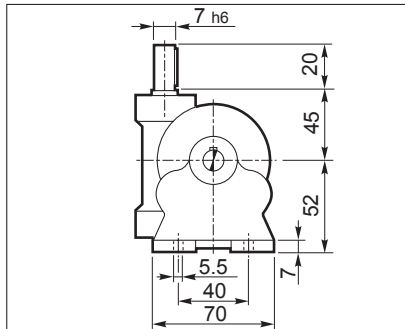

#### VF 27\_F1..HS

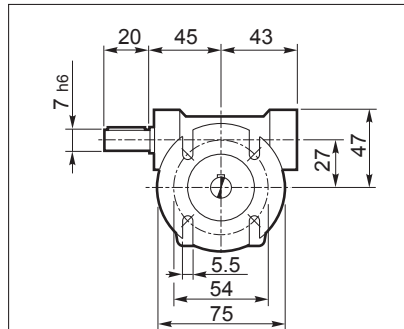

#### VF 27\_F2..HS

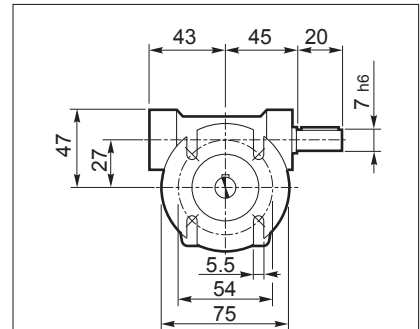

VF 27_HS	0.73

Le dimensioni comuni alle altre configurazioni sono riportate a pag.107.



## VF...HS - W...HS

**VF\_A..HS**

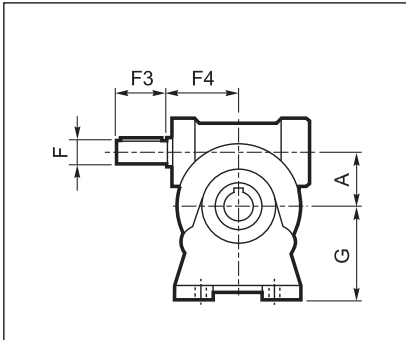

**VF\_V..HS**

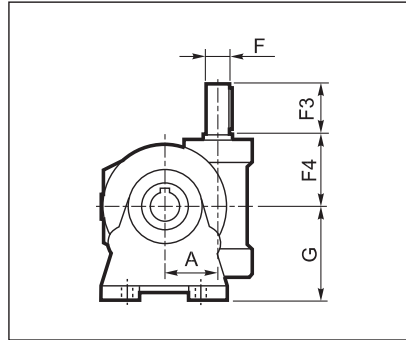

**VF\_N..HS**

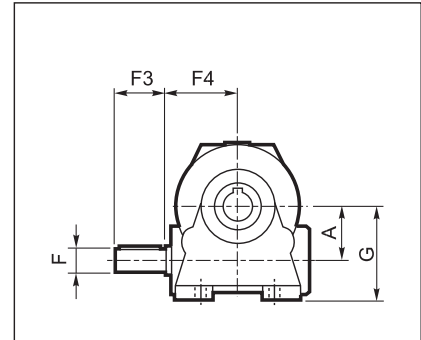

**VF\_P..HS**

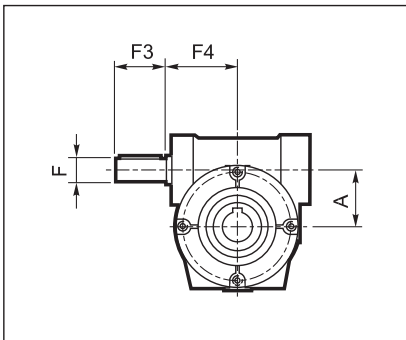

**VF\_FA/FC/FR/F..HS**

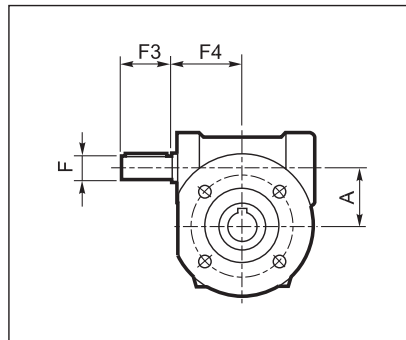

**VF\_U..HS**

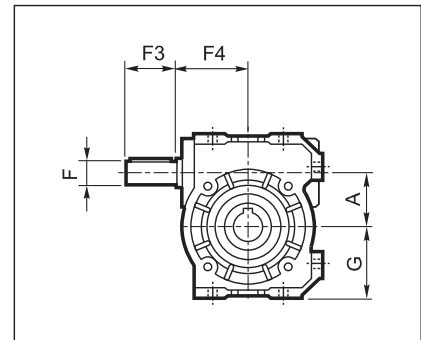

**W\_U..HS**

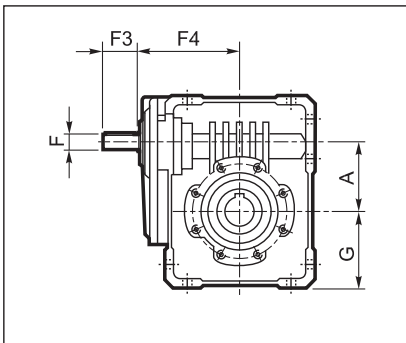

**W\_UF/UFC/UFCR..HS**

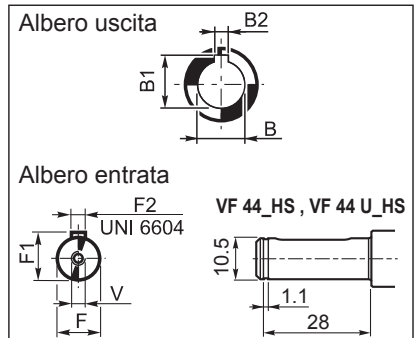
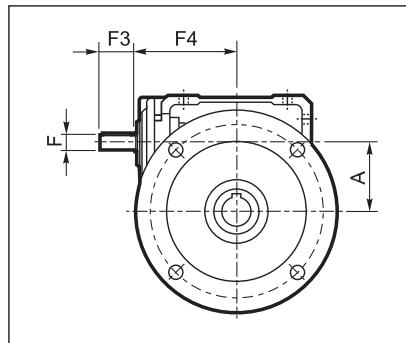

	A	B	B1	B2	F	F1	F2	F3	F4	G	V	Kg
<b>VF 30_HS</b>	30	14 H7	16.3	5 H8	9 h6	10.2	3	20	50	55	—	1.1
<b>VF 30_U_HS</b>										47		
<b>VF 44_HS</b>	44.6	18 H7	20.8	6 H8	11 h6	12.5	4	30	54	72	—	2.0
<b>VF 44_U_HS</b>										55		
<b>VF 49_HS</b>	49.5	25 H7	28.3	8 H8	16 h6	18	5	40	65	82	M6x16	3.0
<b>VF 49_U_HS</b>										64.5		
<b>W 63_HS</b>	62.17	25 H7	28.3	8 H8	18 h6	20.5	6	40	110.5	72.5	M6x16	6.4
<b>W 75_HS</b>	75	30(28) H7	33.3(31.3)	8 H8	19 h6	21.5	6	40	128	87	M6x16	10.0
<b>W 86_HS</b>	86.9	35 H7	38.3	10 H8	25 h6	28	8	50	144	100	M8x19	14.1
<b>W 110_HS</b>	110.1	42 H7	45.3	12 H8	25 h6	28	8	60	168	125	M8x19	27
<b>VF 130_HS</b>	130	45 H7	48.8	14 H8	30 h6	33	8	60	160	195	M8x20	49
<b>VF 150_HS</b>	150	50 H7	53.8	14 H8	35 h6	38	10	65	185	220	M8x20	60
<b>VF 185_HS</b>	185.4	60 H7	64.4	18 H8	40 h6	43	12	70	214.5	254	M8x20	94
<b>VF 210_HS</b>	210	90 H7	95.4	25 H8	48 h6	51.5	14	110	230	335	M16x40	175
<b>VF 250_HS</b>	250	110 G7	116.4	28 H8	55 h6	59	16	110	275.5	380	M16x40	275

Le dimensioni comuni alle altre configurazioni sono riportate da pag.122 a pag. 183.



## VFR...HS - WR...HS

**VFR\_A..HS**

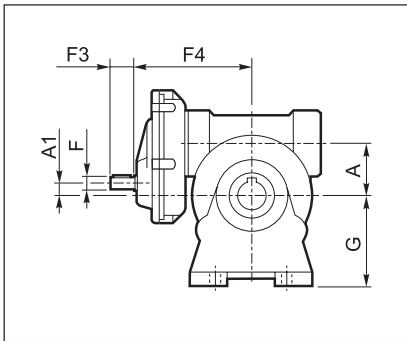

**VFR\_N..HS**

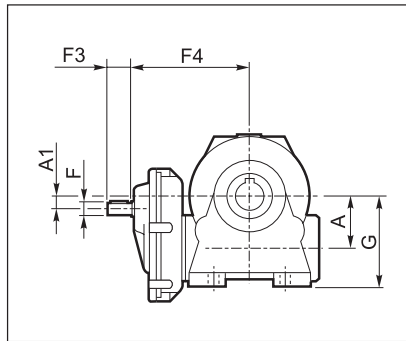

**VFR\_V..HS**

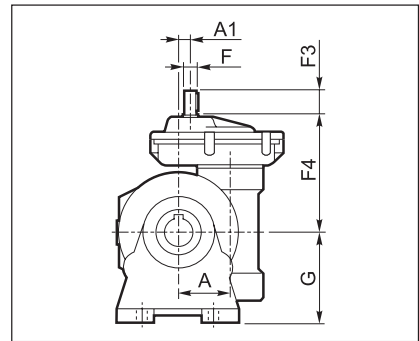

**VFR\_P..HS**

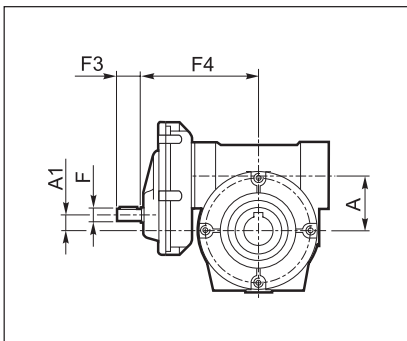

**VFR\_FA/FC/FR/F..HS**

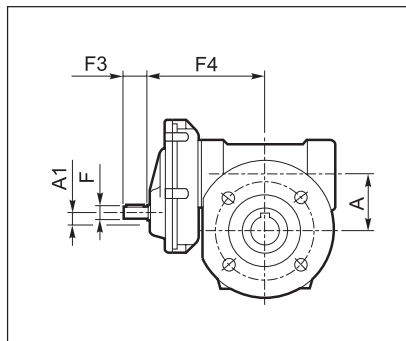

**VFR\_U..HS**

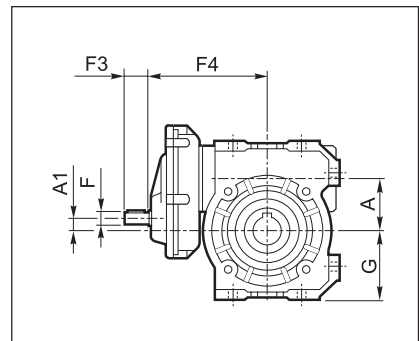

**WR\_U..HS**

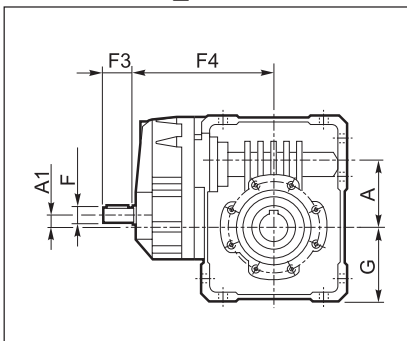

**WR\_UF/UFC/UFCR..HS**

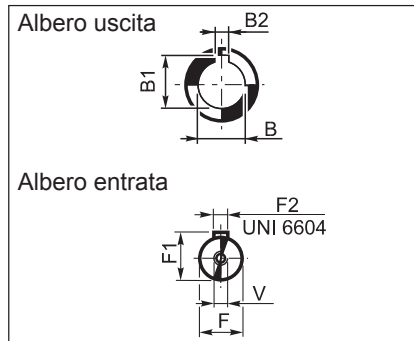
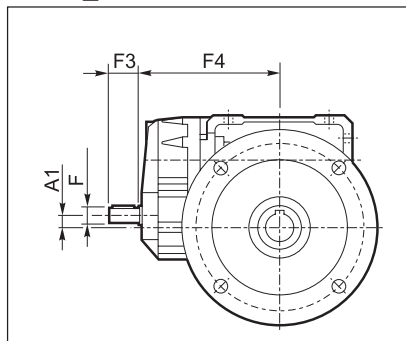

	A	A1	B	B1	B2	F	F1	F2	F3	F4	G	V	Kg
VFR 49_HS	49.5	10	25 H7	28.3	8 H8	11 h6	12.5	4	23	110	82	M4x10	5
VFR 49_U HS											64.5		
WR 63_HS	62.17	11.42	25 H7	28.3	8 H8	14 h6	16	5	30	138	72.5	M5x12.5	7.1
WR 75_HS	75	11	30(28) H7	33.3(31.3)	8 H8	19 h6	21.5	6	40	162	87	M6x16	11.1
WR 86_HS	86.9	22.9	35 H7	38.3	10 H8	19 h6	21.5	6	40	178	100	M6x16	14.7
WR 110_HS	110.1	21.1	42 H7	45.3	12 H8	24 h6	27	8	50	201	125	M8x19	34
VFR 130_HS	130	45	45 H7	48.8	14 H8	24 h6	27	8	50	228	195	M8x20	57
VFR 150_HS	150	53	50 H7	53.8	14 H8	28 h6	31	8	60	280	220	M8x20	71
VFR 185_HS	185.4	88.4	60 H7	64.4	18 H8	28 h6	31	8	60	310	254	M8x20	110
VFR 210_HS	210	92	90 H7	95.4	25 H8	38 h6	41	10	80	335	335	M10x25	185
VFR 250_HS	250	132	110 G7	116.4	28 H8	38 h6	41	10	80	383	380	M10x25	295

Le dimensioni comuni alle altre configurazioni sono riportate da pag.132 a pag. 185.



## VF/VF...HS - VF/W...HS - W/VF...HS

**VF/VF\_A..HS**  
**W/VF\_A..HS**

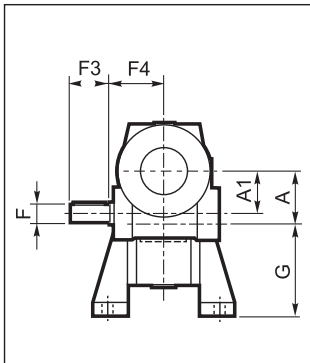

**VF/VF\_N..HS**  
**W/VF\_N..HS**

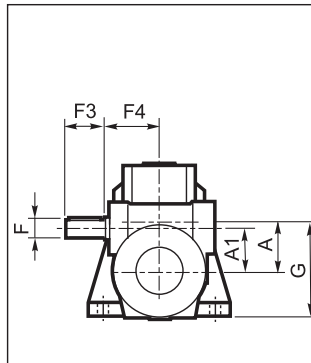

**VF/VF\_V..HS**  
**W/VF\_V..HS**

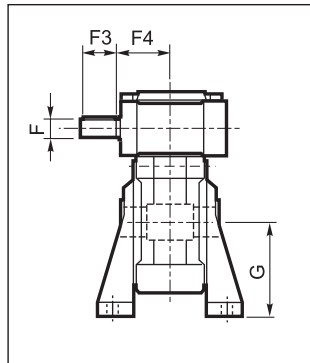

**VF/VF\_P..HS**  
**W/VF\_P..HS**

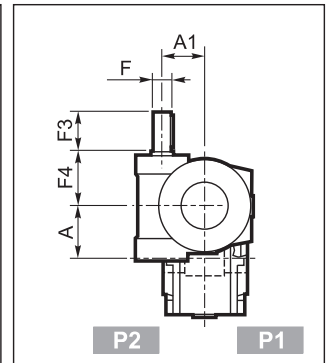

**VF/W\_U..HS**

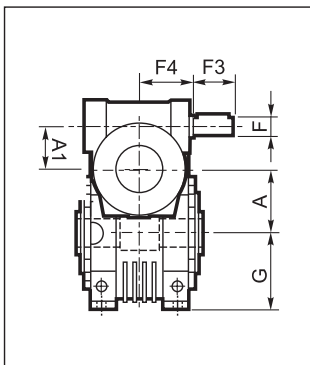

**VF/VF\_U..HS**

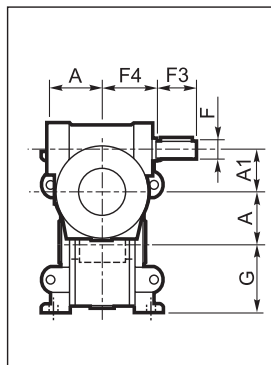

**VF/VF\_F/FA/FC/FR..HS**  
**W/VF\_F/FA/FC/FR..HS**

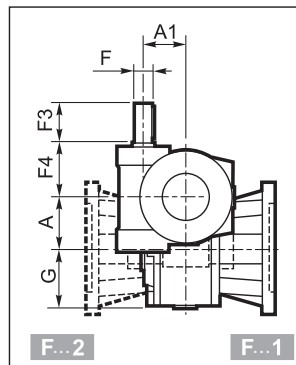

**VF/W\_UF/UFC/UFCR..HS**

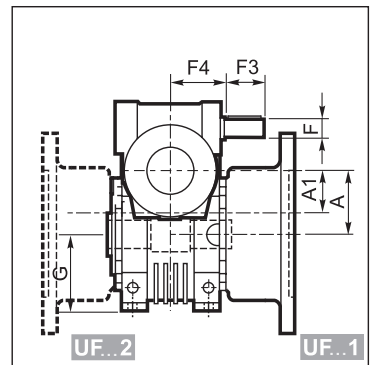

Albero uscita

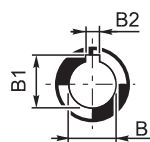

Albero entrata

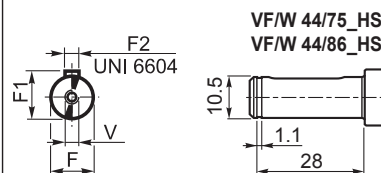

	A	A1	B	B1	B2	F	F1	F2	F3	F4	G	V	Kg
<b>VF/VF 30/44_HS</b>	44.6	30	18 H7	20.8	6 H8	9 h6	10.2	3	20	50	72	—	3.5
<b>VF/VF 30/44_U_HS</b>											55		
<b>VF/VF 30/49_HS</b>	49.5	30	25 H7	28.3	8 H8	9 h6	10.2	3	20	50	82	—	4.5
<b>VF/VF 30/49_U_HS</b>											64.5		
<b>VF/W 30/63_HS</b>	62.17	30	25 H7	28.3	8 H8	9 h6	10.2	3	20	50	100	—	7.5
<b>VF/W 44/75_HS</b>	75	44.6	30 (28) H7	33.3 (31.3)	8 H8	11 h6	12.5	4	30	54	115	—	16.1
<b>VF/W 44/86_HS</b>	86.9	44.6	35 H7	38.3	10 H8	11 h6	12.5	4	30	54	142	—	42
<b>VF/W 49/110_HS</b>	110.0	49.5	42 H7	45.3	12 H8	16 h6	18	5	40	65	170	M6x16	46
<b>W/VF 63/130_HS</b>	130	62.17	45 H7	48.8	14 H8	18 h6	20.5	6	40	110.5	72.5	M6x16	74
<b>W/VF 86/150_HS</b>	150	86.9	50 H7	53.8	14 H8	25 h6	28	8	50	144	100	M8x19	108
<b>W/VF 86/185_HS</b>	185.4	86.9	60 H7	64.4	18 H8	25 h6	28	8	50	144	100	M8x19	109
<b>VF/VF 130/210_HS</b>	210	130	90 H7	95.4	25 H8	30 h6	33	8	60	160	335	M8	225
<b>VF/VF 130/250_HS</b>	250	130	110 G7	116.4	28 H8	30 h6	33	8	60	160	380	M8	325

Le dimensioni comuni alle altre configurazioni sono riportate da pag.128 e pag. 186.



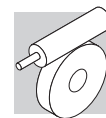

## 28 DIMENSIONI RIDUTTORI CON BRACCIO DI REAZIONE

### VF - VFR - VF/VF - W/VF

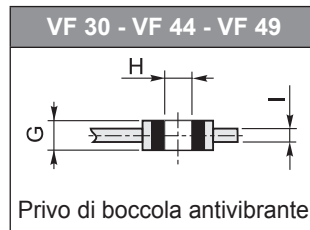
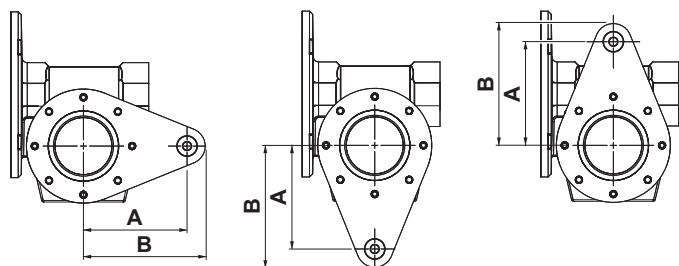

### W - WR - VF/W

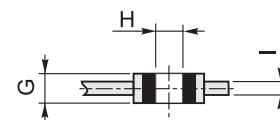
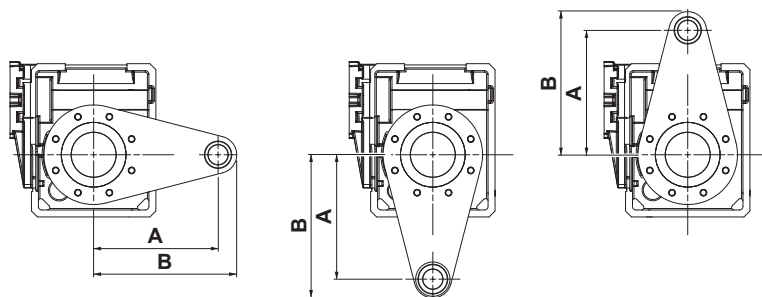

		A	B	G	H	I
VF	30	100	117.5	14	8	4
VFR	44	100	117.5	14	8	4
VF/VF	49	100	117.5	14	8	4
W	63	150	178	20	10	6
WR	75	200	237	25	20	6
VF/W	86	200	238	25	20	6
	110	250	288	25	20	6
	130	300	345	30	25	6
VF	150	300	345	30	25	6
VFR	185	350	395	30	25	6
W/VF	210	350	450	60	50	8
	250	400	500	60	50	10

Le dimensioni comuni alle altre configurazioni sono riportate da pag.122 e pag. 185.

## 29 DIMENSIONI RIDUTTORI CON CAPPELOTTO DI PROTEZIONE

### W - WR - VF/W

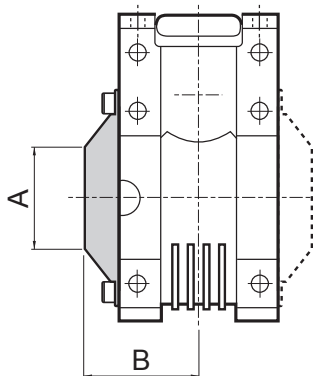

		A	B
	63	Ø 35	82
W	75	Ø 54	85.5
WR	86	Ø 71	93.5
VF/W	110	Ø 89	103

Le dimensioni comuni alle altre configurazioni sono riportate da pag.136 e pag. 150.



## 30 ACCESSORI

### 30.1 Albero lento riportato

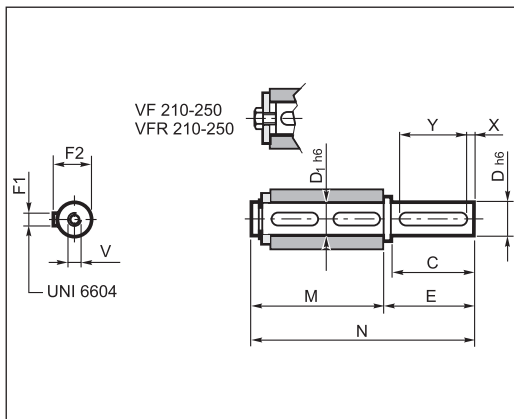

		C	D	D1	E	F1	F2	M	N	V	X	Y
<b>VF</b>	<b>30</b>	30	14	14	35	5	16	61	96	M5x13	5	20
<b>VFR</b>	<b>44</b>	40	18	18	45	6	20.5	70	115	M6x16	5	30
<b>VF/VF</b>	<b>49</b>	60	25	25	65	8	28	89	154	M8x19	5	50
	<b>63</b>	60	25	25	65	8	28	127	192	M8x19	5	50
<b>W</b>	<b>75_D28</b>	60	28	30	65	8	31	134	199	M8x20	5	50
<b>WR</b>	<b>75_D30</b>	60	30	30	65	8	33	134	199	M10x22	5	50
<b>VF/W</b>	<b>86</b>	60	35	35	65	10	38	149	214	M10x22	5	50
	<b>110</b>	75	42	42	80	12	45	164	244	M12x28	7.5	60
<b>VF</b>	<b>130</b>	80	45	45	85	14	48.5	176	261	M12x32	5	70
<b>VFR</b>	<b>150</b>	85	50	50	93	14	53.5	185	278	M16x40	7.5	70
<b>W/VF</b>	<b>185</b>	100	60	60	110	18	64	200	310	M16x40	10	80
	<b>210</b>	130	90	90	140	25	95	255	395	M20x50	5	120
	<b>250</b>	165	110	110	175	28	116	315	490	M24x64	15	140

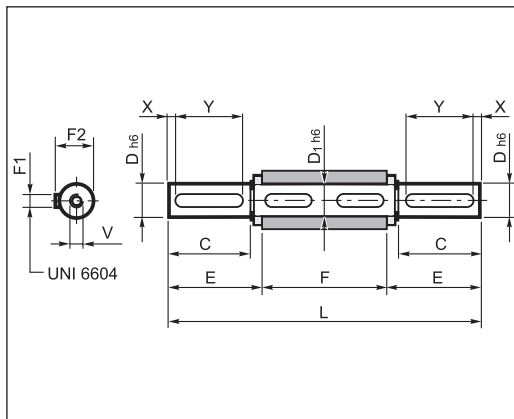

		C	D	D1	E	F	F1	F2	L	V	X	Y
<b>VF</b>	<b>30</b>	30	14	14	32.5	55	5	16	120	M5x13	5	20
<b>VFR</b>	<b>44</b>	40	18	18	42.7	64	6	20.5	149.4	M6x16	5	30
<b>VF/VF</b>	<b>49</b>	60	25	25	63.2	82	8	28	208.4	M8x19	5	50
	<b>63</b>	60	25	25	63.2	120	8	28	246.4	M8x19	5	50
<b>W</b>	<b>75_D28</b>	60	28	30	64	127	8	31	255	M8x20	5	50
<b>WR</b>	<b>75_D30</b>	60	30	30	64	127	8	33	255	M10x22	5	50
<b>VF/W</b>	<b>86</b>	60	35	35	64	140	10	38	268	M10x22	5	50
	<b>110</b>	75	42	42	79.3	155	12	45	313.5	M12x28	7.5	60
<b>VF</b>	<b>130</b>	80	45	45	84.7	165	14	48.5	334.5	M12x32	5	70
<b>VFR</b>	<b>150</b>	85	50	50	90	175	14	53.5	355	M16x40	7.5	70
<b>W/VF</b>	<b>185</b>	100	60	60	105	190	18	64	400	M16x40	10	80
	<b>210</b>	130	90	90	140	260	25	95	540	M20x50	5	120
	<b>250</b>	165	110	110	175	320	28	116	670	M24x64	15	140

### 30.2 Kit piedi KA, KV

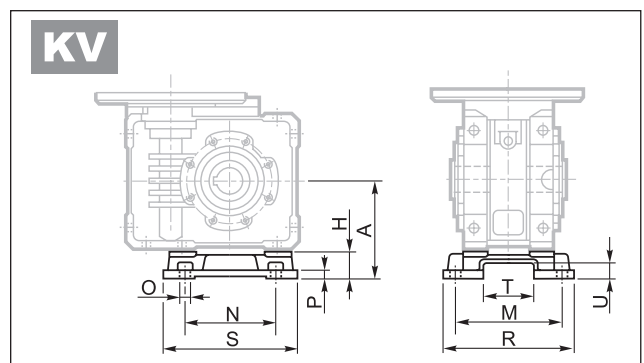
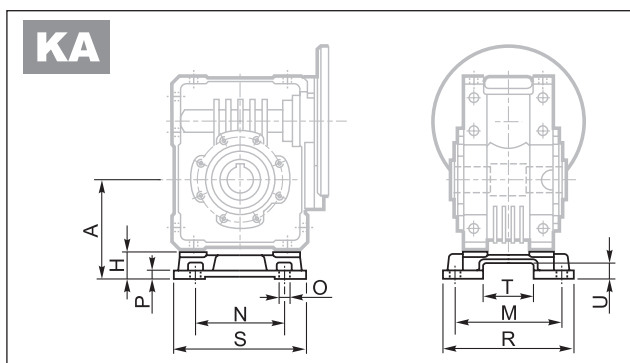

	A	H	M	N	O	P	R	S	T	U
<b>W 63 - WR 63</b>	100	27.5	111	95	11	8	135	145	56.5	15.5
<b>W 75 - WR 75</b>	115	28	115	120	11	9	139	174	56.5	15.5
<b>W 86 - WR 86</b>	142	42	146	140	11	11	170	200	69	20
<b>W 110 - WR 110</b>	170	45	181	200	13	14	210	250	69	20

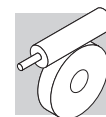

## 31 ALBERO CLIENTE

Realizzare l'albero condotto che si accoppierà con il riduttore con un acciaio di buona qualità, rispettando le dimensioni riportate in tabella.

Si suggerisce inoltre di completare il montaggio con un dispositivo di bloccaggio assiale dell'albero, ad esempio come illustrato nel seguito, avendo cura di verificare e dimensionare i vari componenti in funzione delle diverse esigenze applicative.

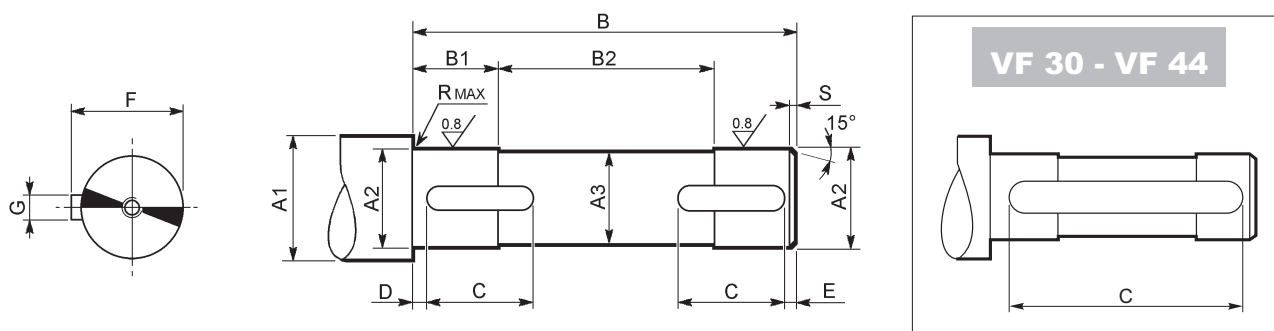

	A1	A2	A3	B	B1	B2	C	D	E	F	G	R	S	 UNI 6604
<b>VF 30</b>	≥ 19	14 f7	13	53	18.5	16	40	6.5	6.5	16	5 h9	0.5	1.5	5x5x40 A
<b>VF 44</b>	≥ 23	18 f7	17	62	22.5	17	50	6	6	20.5	6 h9	0.5	1.5	6x6x50 A
<b>VF 49</b>	≥ 30	25 f7	24	80	20.5	39	20	2	2	28	8 h9	1	1.5	8x7x20 A
<b>W 63</b>	≥ 30	25 f7	24	118	38	42	35	2	2	28	8 h9	1	1.5	8x7x35 A
<b>W 75</b>	≥ 35	28 f7	27	125	38	49	40	2	2	31	8 h9	1	1.5	8x7x40 A
	≥ 35	30 f7	29	125	38	49	40	2	2	33	8 h9	1	1.5	8x7x40 A
<b>W 86</b>	≥ 42	35 f7	34	138	43	52	40	2	2	38	10 h9	1.5	1.5	10x8x40 A
<b>W 110</b>	≥ 48	42 f7	41	153	43	67	50	2	2	45	12 h9	1.5	2	12x8x50 A
<b>VF 130</b>	≥ 52	45 f7	44	163	50.5	62	60	2.5	2.5	48.5	14 h9	2.5	2	14x9x60 A
<b>VF 150</b>	≥ 57	50 f7	49	173	53	67	70	2.5	2.5	53.5	14 h9	2.5	2	14x9x70 A
<b>VF 185</b>	≥ 68	60 f7	59	188	63	62	80	2.5	2.5	64	18 h9	2.5	2	18x11x80 A
<b>VF 210</b>	≥ 99	90 f7	89	258	83	92	80	3	3	95	25 h9	2.5	2.5	25x14x80 A
<b>VF 250</b>	≥ 121	110 h7	109	318	83	152	80	3	3	116	28 h9	2.5	2.5	28x16x80 A



## 32 LIMITATORE DI COPPIA

### 32.1 Descrizione

Il limitatore di coppia a frizione è studiato e realizzato per i riduttori senza fine **VF44 - VF49** e **W63... W110**, è un dispositivo di protezione atto a salvaguardare la trasmissione da sovraccarichi accidentali che potrebbero danneggiare tutti gli elementi della trasmissione creando seri inconvenienti alla macchina operatrice.

Rispetto ai tradizionali limitatori di coppia montati esternamente al riduttore questa versatile soluzione presenta i seguenti vantaggi:

- nessun ingombro aggiuntivo esterno ai riduttori forniti in versione standard
- lavorando a completo bagno d'olio non richiede nessuna manutenzione
- La coppia di slittamento puo essere facilmente regolata tramite una semplice operazione manuale dall'esterno del riduttore
- lo slittamento, anche continuo, non crea danneggiamenti alla meccanica o consumi anormali, in quanto le superfici di slittamento sono separate da un costante velo d'olio.



**Se ne sconsiglia l'utilizzo in meccanismi di sollevamento.**

### 32.2 Modo di funzionamento

Il limitatore di coppia funziona come una frizione biconica con le sedi ricavate direttamente sulla corona in bronzo e sul mozzo in ghisa sferoidale GS400/12 monolitica avente l'albero lento cavo passante, il quale permette di collegare la macchina operatrice direttamente al nostro riduttore.

Le sedi coniche sono strette fra loro per effetto di una forza assiale costante generata da molle a tazza.

La registrazione della coppia di slittamento si effettua in modo semplice tramite la rotazione di una ghiera esterna al riduttore.

### 32.3 Protezione dell'impianto da sovraccarichi

Il limitatore opportunamente tarato alla coppia necessaria alla macchina operatrice, salvaguarda tutti gli organi meccanici del cinematismo evitando danneggiamenti dovuti a eventuali e ripetuti sovraccarichi.

### 32.4 Disinserimento in condizioni di irreversibilità

In determinate applicazioni può essere utile ruotare, a macchina ferma, l'albero lento del riduttore. Questa situazione non e sempre possibile nei riduttori a vite senza fine tradizionali. Tramite questo dispositivo, allentando opportunamente la ghiera di registrazione, possiamo eseguire agevolmente questa operazione.



### 32.5 VF...L, W...L

L1								L2								
	N	A	V	U	F1 FC1 FR1 FA1	F2 FC2 FR2 FA2**	P1 P2		N	A	V	U	F1 FC1 FR1 FA1**	F2 FC2 FR2 FA2	P1 P2	
VF VF/VF*									VF VF/VF*							
	U	UF1 UFC1	UF2 UFC2	UFCR1	UFCR2				U	UF1 UFC1	UF2 UFC2	UFCR1	UFCR2			
W VF/W*									W VF/W*							

\* Nei riduttori combinati, il limitatore di coppia è installato sul 2° riduttore nelle esecuzioni L1 ed L2; è installato sul 1° riduttore nell'esecuzione LF.

LF				
	VF/W	44/75	44/86	49/110
	W/VF	63/130	86/150	86/185

Se non preventivamente specificato, i riduttori VF...L verranno forniti con la ghiera a sinistra (L1) guardando il motore elettrico in posizione di montaggio B3.

### 32.6 Dimensioni

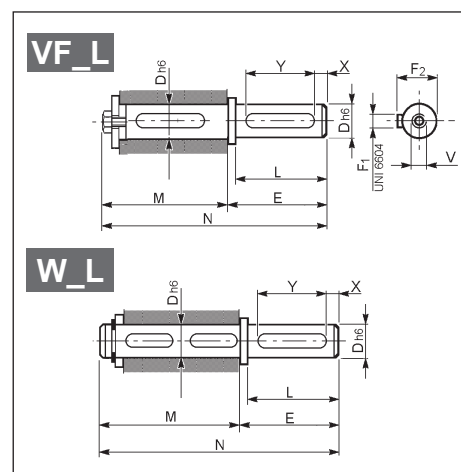
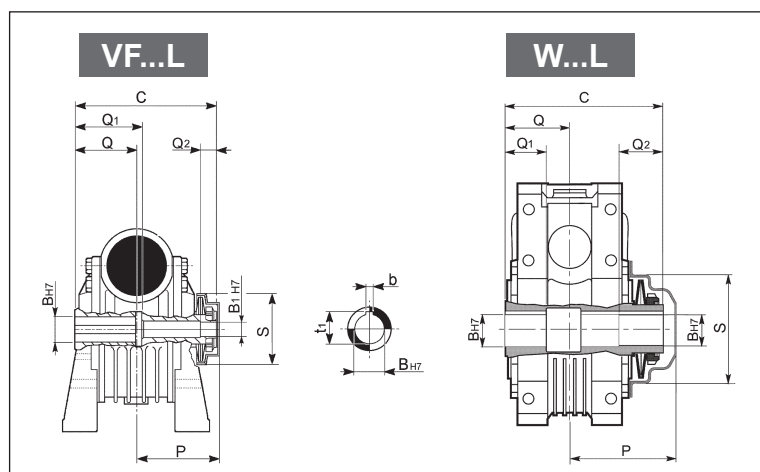

	Limitatore di coppia										Albero lento semplice									
	C	Q	Q1	Q2	P	S	B <sub>H7</sub>	B <sub>1H7</sub>	t <sub>1</sub>	b	L	D <sub>h6</sub>	E	F1	F2	M	N	V	X	Y
VF 44L	79	27	32	12	48	42.5	18	11	20.8	6	40	18	45	6	20.5	86	131	M6x16	5	30
VF 49L	105	47	51	15	63.5	66.5	25	14	28.3	8	60	25	65	8	28	114.5	179.5	M8x19	5	40
W 63L	145	60	40	40	100	77	25	-	28.3	8	60	25	65	8	28	152	217	M8x19	5	50
W 75L_D30	154.5	63.5	40	40	104	100	30	-	33.3	8	60	30	65	8	33	161.5	226.5	M10x22	5	50
W 86L	170	70	50	45	113	119	35	-	38.3	10	60	35	65	10	38	179	244	M10x22	5	50
W 110L	191	77.5	55	45	133	134	42	-	45.3	12	75	42	80	12	45	200	280	M12x28	7.5	60

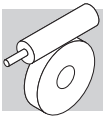

### 32.7 Registrazione coppia di slittamento

In fabbrica viene eseguita una pretaratura dello slittamento su un momento torcente coincidente col valore di coppia nominale  $Mn_2$  [ $n_1=1400$ ] del riduttore tipo VF o W.

Qui di seguito sono descritte le operazioni eseguite in fabbrica per realizzare la taratura della coppia di slittamento. Le stesse operazioni, a meno del passo (2), dovranno essere ripercorse quando si vuole impostare un valore di coppia diverso dall'originale.

1. La ghiera di registrazione viene avvitata fino a che le molle a tazza non sono sufficientemente caricate da non potere ruotare liberamente, se azionate manualmente.

2. Per mezzo di un bulino vengono incise, in identica posizione angolare, due marcature di riferimento, sia sulla ghiera che sulla sporgenza d'albero lento.

Questa posizione di riferimento costituirà il punto iniziale per il conteggio dei successivi giri della ghiera e la conseguente taratura di coppia.

3. Infine la ghiera viene avvitata delle frazioni di giro corrispondenti al valore di coppia nominale  $Mn_2$  del riduttore in oggetto. Il riferimento in questo caso è il diagramma sotto riportato, il quale sarà d'utilità anche per le eventuali nuove impostazioni che si dovessero rendere necessarie nel tempo.

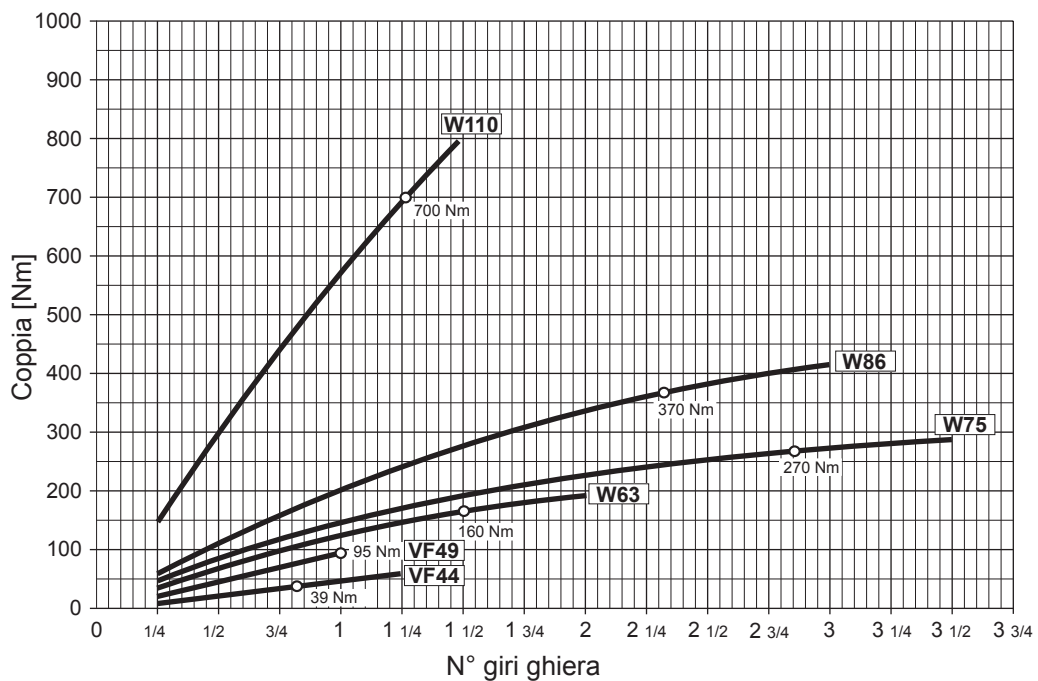

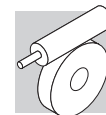

## VF-EP / W-EP - RIDUTTORI E MOTORIDUTTORI PER AMBIENTI CORROSIVI E ASETTICI

### 33 I VANTAGGI DELL'ESECUZIONE EP PER L'INDUSTRIA

Le compagnie dei settori alimentare, chimico o farmaceutico hanno oggi a disposizione una nuova gamma di motoriduttori appositamente studiati per operare in maniera efficace in ambienti caratterizzati da elevati standard igienici e agenti ostili che sono tipici di questa tipologia di industrie.

**Ideali per le industrie di processo alimentari**

**Resistenti alla corrosione**

**Servizio idoneo per gli ambienti più ostili**

**Lavabili/sanificabili con i detergenti più comunemente utilizzati**

### CARATTERISTICHE PRINCIPALI

#### Standard:

- Albero cavo, targhette e viteria in acciaio inossidabile
- Riduttore completamente sigillato
- Chiusura dei fori filettati non utilizzati mediante tappi a pressione
- Fori per il drenaggio dell'acqua
- Protezione del motore IP56
- Protezione contro la corrosione in classe C5 oppure verniciature alimentari approvate da FDA & NSF

#### Opzioni Principali:

- Anelli di tenuta per lavaggi con getti d'acqua in pressione
- Lubrificante compatibile con gli alimenti omologato da NSF (H1) e FDA



## PRINCIPALI VANTAGGI DELL'ESECUZIONE EP

Grazie alla completa ermeticità del riduttore ed alle verniciature e protezioni superficiali dedicate, i motoriduttori della serie EP assicurano un funzionamento affidabile e privo di rischi in ambienti sia corrosivi che igienici, facilitando inoltre al cliente la sanitizzazione del motoriduttore.

L'intero motoriduttore è infatti protetto da un sistema epossidico multistrato con elevate proprietà di tenuta, che garantisce alta resistenza a corrosione ed abrasione.

Due differenti sistemi di finitura possono essere selezionati:

- Il primo garantisce una resistenza alla corrosione di classe C5 in accordo alla norma ISO 9223 ed è disponibile come standard in RAL9006.
- Il secondo è dedicato alle industrie alimentari ed è registrato da NSF e FDA come compatibile per l'utilizzo in aree dove è possibile il contatto accidentale con cibo o con acqua potabile. Inoltre, oltre a garantire una comunque elevata resistenza alla corrosione, questa finitura è anche lavabile con la maggior parte dei detergenti comunemente utilizzati nelle industrie alimentari.

**NOTA:** Questa finitura è automaticamente selezionata quando il colore specificato per il motoriduttore è Light Blue\*(PLB) o White\*(PWH).

\*Nota: Non è possibile specificare un RAL in quanto la vernice è a base organica.

Infine, i motoriduttori della serie EP possono essere ulteriormente adattati a specifiche richieste attraverso varie opzioni e accessori.

Grandezze di riduttore disponibili in versione EP: VF44 (Escluso VFR), VF49, W63, W75, W86.

Motorizzazioni disponibili: da 0.12 a 4.0kW in esecuzione sia compatta che IEC in 2, 4 e 6 poli.



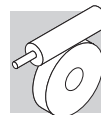

### ALLESTIMENTO RIDUTTORE

- ① Il riduttore è completamente sigillato allo scopo di minimizzare ogni possibile contaminazione dell'ambiente esterno.
- ② Albero lento cavo in acciaio inossidabile AISI 316.
- ③ Targhetta e viteria in acciaio inossidabile.
- ④ Cassa progettata per drenaggio acqua, per evitarne il ristagno dopo il lavaggio.
- ⑤ È disponibile in opzione olio sintetico omologato da NSF quale lubrificante H1 per l'uso nell'industria alimentare e farmaceutica e compatibile con le norme FDA per il contatto accidentale con gli alimenti.

- ⑥ Disponibili tenute in PTFE con schermo in inox, resistenti ai lavaggi in pressione.
- ⑦ Trattamento epossidico delle superfici esterne, approvato FDA e NSF (in funzione della tinta scelta) per il contatto accidentale con gli alimenti e altamente resistente alla corrosione.
- ⑧ Chiusura dei fori filettati non utilizzati mediante tappi a pressione.

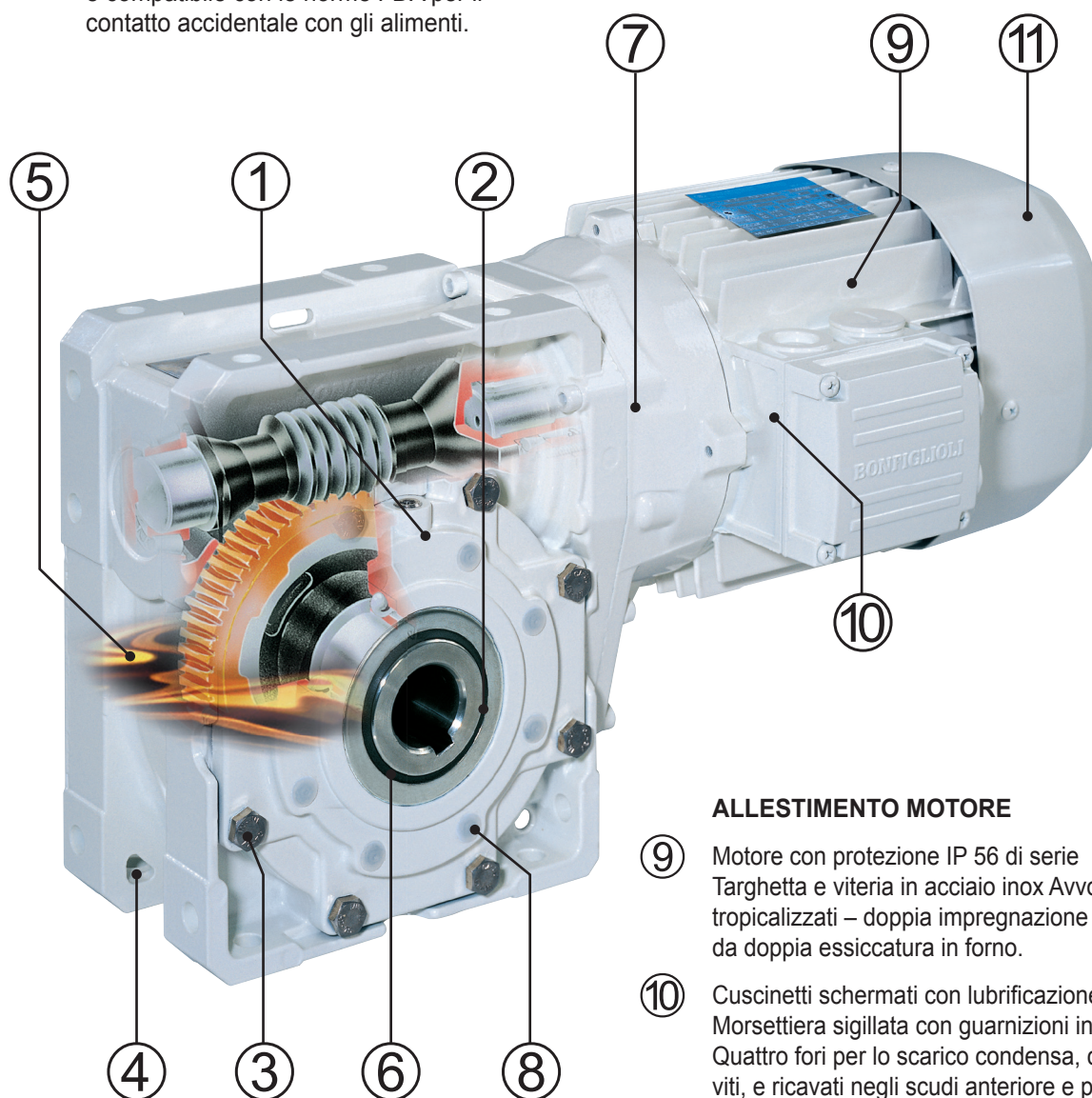

### ALLESTIMENTO MOTORE

- ⑨ Motore con protezione IP 56 di serie Targhetta e viteria in acciaio inox Avvolgimenti tropicalizzati – doppia impregnazione seguita da doppia essiccazione in forno.
- ⑩ Cuscinetti schermati con lubrificazione “a vita”. Morsettiera sigillata con guarnizioni in NBR. Quattro fori per lo scarico condensa, chiusi con viti, e ricavati negli scudi anteriore e posteriore. Giunti di accoppiamento scudi-cassa sigillati.
- ⑪ Ventola di raffreddamento in materiale poliammidico, compatibile con gli alimenti.



### RIDUTTORE

**W-EP — 63 U 30 P90 B14 B3 PWH** ....

OPZIONI

#### VERNICE

<b>NP*</b> vernice assente	
<b>PWH</b> (conforme a FDA e NSF)	
<b>PLB</b> (conforme a FDA e NSF)	
<b>RAL9006</b> (alta resistenza alla corrosione C5)	

#### POSIZIONE DI MONTAGGIO

VF-EP 44 VF-EP 49	<b>B3</b>
W-EP 63 W-EP 75 W-EP 86	<b>B3 (default), B6, B7, B8, V5, V6</b>

#### FORMA COSTRUTTIVA MOTORE

**B5, B14** (IEC standard)

#### DESIGNAZIONE INGRESSO

	VF-EP	VF-EP R	W-EP	W-EP R
<b>P(IEC)</b>	 P63...P80	 P63	 P71...P112	 P63...P90
<b>S_</b>			 S1...S3	

#### RAPPORTO DI RIDUZIONE

#### FORMA COSTRUTTIVA

#### GRANDEZZA RIDUTTORE

VF-EP: **44, 49**  
W-EP: **63, 75, 86**

- (blank)
- R (precoppia elicoidale VF-EP 44)

#### TIPO RIDUTTORE

**VF-EP**  
**W-EP**

\*Nota: Nel caso in cui il riduttore sia richiesto in versione NP (Non Verniciato) e con braccio di reazione, quest'ultimo viene fornito con applicato un primer di colore grigio chiaro completamente sovraverniciabile.

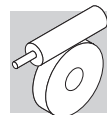



MOTORE

**BE-EP 80B 4 B14 230/400-50 CLF .... PWH ....**

OPZIONI

VERNICE

<b>NP*</b> vernice assente	
<b>PWH</b> (conforme a FDA e NSF)	
<b>PLB</b> (conforme a FDA e NSF)	
<b>RAL9006</b> (alta resistenza alla corrosione C5)	

POSIZIONE MORSETTIERA  
**W** (default), **N, E, S**

CLASSE ISOLAMENTO  
**CL F** standard  
**CL H** option

TENSIONE - FREQUENZA

FORMA COSTRUTTIVA  
— (motore integrato)  
**B5, B14** (motore IEC)

NUMERO DI POLI  
**2, 4, 6,**

GRANDEZZA MOTORE  
**1SC ... 3LB** (motore integrato)  
**63 ... 112** (motore IEC)

TIPO MOTORE

**M-EP** = trifase integrato  
**BN-EP** = trifase IEC

**ME-EP** = trifase integrato, classe IE2  
**BE-EP** = trifase IEC, classe IE2



## 35 OPZIONI RIDUTTORE

### PX

Opzione Anelli di tenuta albero lento. Gli speciali anelli di tenuta offerti in opzione estendono l'applicabilità dei riduttori ai processi in cui sono frequenti i lavaggi con getti d'acqua in pressione.

Lo schermo esterno in acciaio INOX e la realizzazione a doppio labbro infatti aggiungono alla funzionalità di base anche la resistenza alla pressione esterna, mentre il particolare materiale utilizzato (PTFE) garantisce eccezionale resistenza agli elementi chimici aggressivi, basso coefficiente d'attrito e lunga durata.

### PV

Anelli di tenuta in fluoro-elastomero su albero lento. Molla interna in acciaio inox.

### UH1

Opzione Olio compatibile con gli alimenti. Il riduttore viene riempito in fabbrica con lubrificante "long life" rispondente ai requisiti delle Normative più diffuse e in particolare è omologato da NSF quale lubrificante H1 per l'uso nell'industria alimentare e farmaceutica, inoltre soddisfa le norme FDA 21 CFR Sec. 178.3570.

La sua natura sintetica a base di poliglicoli, oltre ad estenderne l'uso ad un ampio campo di temperature (-25° C sino a +150° C), non rende necessarie sostituzioni periodiche e pertanto, in assenza di contaminanti, il lubrificante potrà considerarsi "a vita".

## PROVE DOCUMENTALI

### AC - Attestato di conformità

Documento il cui rilascio attesta la conformità del prodotto all'ordinativo e la costruzione dello stesso in conformità alle procedure standard di processo e di controllo previste dal sistema di Qualità Bonfiglioli Riduttori.

### CC - Certificato di collaudo

La specifica comporta la conduzione di verifiche di conformità all'ordine, controlli visivi generali e verifiche strumentali delle dimensioni di accoppiamento. Sono inoltre condotti controlli generali di funzionamento a vuoto e verifiche della funzionalità delle guarnizioni di tenuta in modalità statica e in funzionamento. Il collaudo si applica ad un campione statistico del lotto di spedizione.

## 36 OPZIONI MOTORI

Le opzioni disponibili per tutti i motori EP sono: D3, E3, K1, H1, NH1, RC, RV, ACM, CC, CUS, S2, S3, S9.

Per informazioni sulle opzioni, consultare i relativi capitoli nella sezione Motori Elettrici.

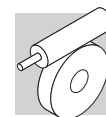

## 37 ALTRE INFORMAZIONI SUI RIDUTTORI E I MOTORIDUTTORI

Le posizioni di montaggio, i dati tecnici, le predisposizioni motore, i momenti d'inerzia e le dimensioni dei riduttori **VF-EP** e **W-EP** non cambiano rispetto all'equivalente prodotto delle serie **VF** e **W**. Allo stesso modo le informazioni relative a tutti i motori **EP** non cambiano rispetto agli equivalenti motori di serie. Tutte queste informazioni possono essere reperite nei relativi capitoli di questo catalogo.

## 38 GLI ACCESSORI DELLA SERIE EP

A seconda delle necessità applicative potranno essere richiesti determinati accessori che completano l'architettura del prodotto, e in particolare:

- albero lento, sia semplice che bilaterale, in acciaio INOX tipo 316, completo di chiavette in identico materiale
- braccio di reazione in lamiera verniciata (specificare la sigla tra quelle riportate nella relativa figura)
- coperchio di sicurezza per la zona albero lento (cavo) in plastica (W63, W75 e W86) o lamiera rivestita in gomma NBR (VF 44, VF 49) con viteria in acciaio INOX e grado di protezione complessivo IP56.

### 38.1 Albero lento riportato

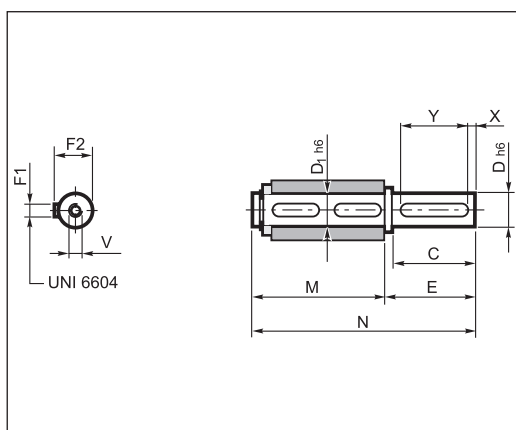

	C	D	D1	E	F1	F2	M	N	V	X	Y
<b>VF-EP 44</b>	40	18	18	45	6	20.5	70	115	M6x16	5	30
<b>VF-EP 49</b> <b>VF-EP R 49</b>	60	25	25	65	8	28	89	154	M8x19	5	50
<b>W-EP 63</b> <b>W-EP R 63</b>	60	25	25	65	8	28	127	192	M8x19	5	50
<b>W-EP 75</b> <b>W-EP R 75</b>	60	30	30	65	8	33	134	199	M10x22	5	50
<b>W-EP 86</b> <b>W-EP R 86</b>	60	35	35	65	10	38	149	214	M10x22	5	50

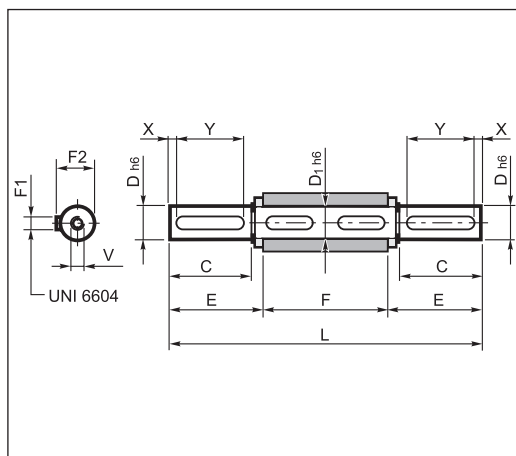

	C	D	D1	E	F	F1	F2	L	V	X	Y
<b>VF-EP 44</b>	40	18	18	42.7	64	6	20.5	149.4	M6x16	5	30
<b>VF-EP 49</b> <b>VF-EP R 49</b>	60	25	25	63.2	82	8	28	208.4	M8x19	5	50
<b>W-EP 63</b> <b>W-EP R 63</b>	60	25	25	63.2	120	8	28	246.4	M8x19	5	50
<b>W-EP 75</b> <b>W-EP R 75</b>	60	30	30	64	127	8	33	255	M10x22	5	50
<b>W-EP 86</b> <b>W-EP R 86</b>	60	35	35	64	140	10	38	268	M10x22	5	50



## 38.2 Braccio di reazione

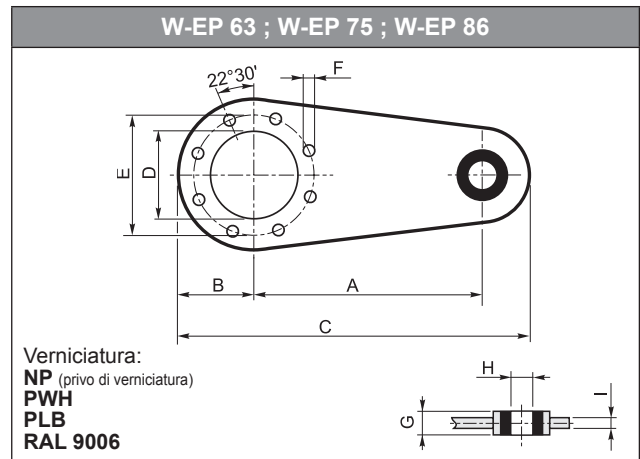
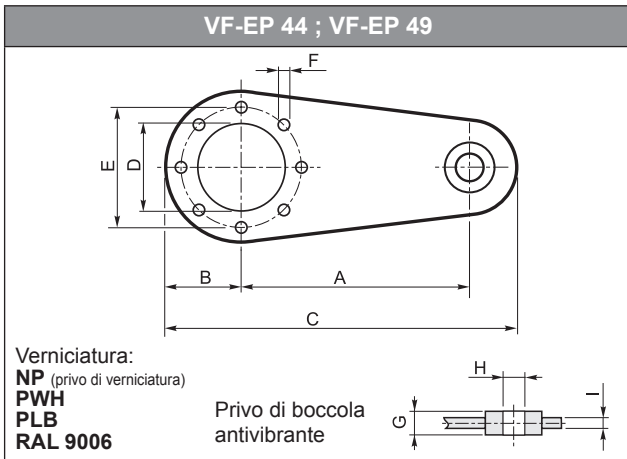

	A	B	C	D	E	F	G	H	I
<b>VF-EP 44</b>	100	40	157.5	50	65	7	14	8	4
<b>VF-EP 49</b> <b>VF-EP R 49</b>	100	55	172.5	68	94	7	14	8	4
<b>W-EP 63</b> <b>W-EP R 63</b>	150	55	233	75	90	9	20	10	6
<b>W-EP 75</b> <b>W-EP R 75</b>	200	63	300	90	110	9	25	20	6
<b>W-EP 86</b> <b>W-EP R 86</b>	200	80	318	110	130	11	25	20	6

## 38.3 Cappello di protezione

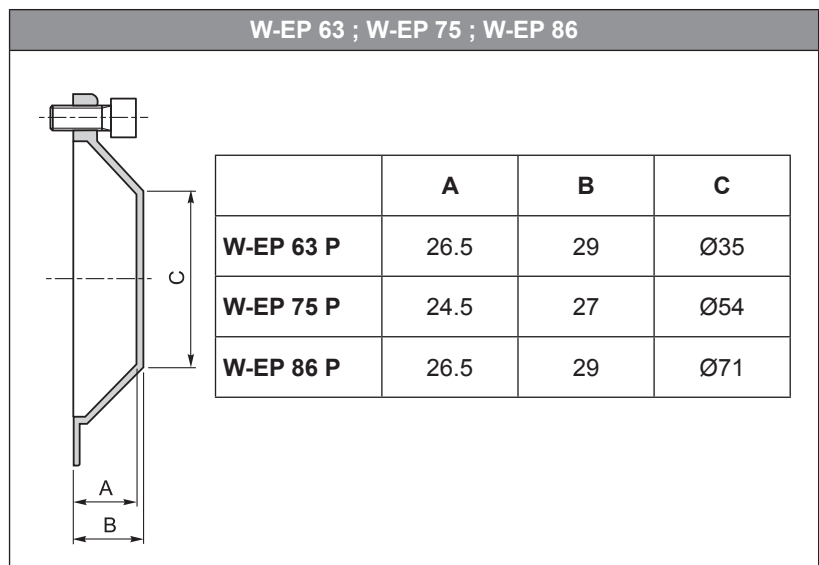
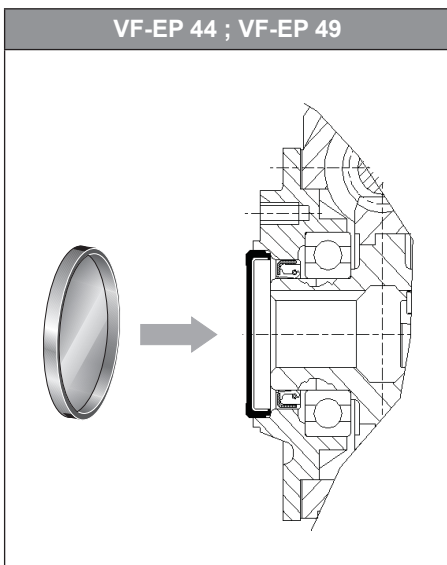

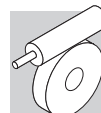

## DISPOSITIVO FINE-CORSA RVS

### 39 INFORMAZIONI GENERALI

Il dispositivo fine-corsa, tipo RVS, è progettato per completare ed adattare i motoriduttori a vite senza fine di Bonfiglioli Riduttori all'azionamento di:

- finestre e ombreggi per serre
- cancelli automatici
- finestre a vasistas
- dosatori per granaglie nel settore zootecnico
- valvole a farfalla

I motoriduttori dotati del dispositivo **RVS** sono anche idonei per qualsiasi altra applicazione intermittente, in cui si richieda un moto controllato e preciso.

Per le applicazioni sopra descritte, caratterizzate da un tipo di servizio leggero e intermittente, si raccomanda di effettuare la selezione del gruppo di trasmissione unicamente dalle pagine del paragrafo 40.

Le selezioni così effettuate saranno conformi al particolare tipo di servizio e alle massime velocità compatibili con il regolare funzionamento del dispositivo fine-corsa.

**La configurazione completa si ottiene assemblando il dispositivo fine-corsa sul relativo motoriduttore, mediante lo specifico kit di montaggio (disponibile per i gruppi tipo VF 49, W63, W75 e W86), illustrato alla pagina seguente.**

Per consentire il montaggio del dispositivo **RVS**, i motoriduttori devono essere nella forma costruttiva flangiata.

#### 39.1 Caratteristiche tecniche

Il funzionamento del dispositivo fine-corsa si basa sul movimento differenziale di due coppie di ruote, dotate di camma, e dal relativo azionamento di microinterruttori di precisione che attraverso relais (a cura dell'installatore) comandano l'arresto e l'inversione del moto.

Le posizioni estreme del moto, tipicamente l'apertura e la chiusura del telaio, sono facilmente impostabili con il motoriduttore già installato e senza l'uso di specifiche attrezzature, al di fuori di una comune chiave a brugola.

Una volta raggiunta e fissata la regolazione desiderata, questa viene mantenuta costante nel tempo, consentendo una elevata ripetibilità negli azionamenti.

Nella sua esecuzione di base il gruppo fine-corsa **RVS** è fornito con una coppia di cavi, della lunghezza di ca. un metro, pre-cablati internamente.

Il gruppo è inoltre disponibile anche nelle seguenti varianti:

**RVS ME:** dotato di scatola morsettiera esterna a sei terminali, ai quali allacciare i cavi di collegamento con i relais.

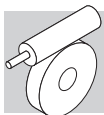

**RVS DM:** corredato di doppia serie di microinterruttori collegati in serie, per una sicurezza di intervento assoluta e conforme alle Norme che prevedono la ridondanza di questo dispositivo.



**RVS ME DM:** dispositivo dotato di morsettiera esterna e di doppia serie di microinterruttori, come più sopra descritto.

In tutte le sue varianti il dispositivo fine-corsa si caratterizza come:

- estremamente silenzioso
- di ingombro contenuto
- di facile installazione e regolazione
- dotato di protezione complessiva IP55
- regolabile all'interno di un campo massimo di 43 giri dell'albero Lento

#### 40 CODICI PER L'ORDINATIVO

Individuare il dispositivo, o la sua variante, necessario per l'applicazione e riferirsi alla tabella sottostante per il relativo codice per l'ordinativo:

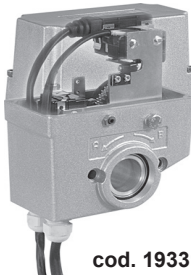
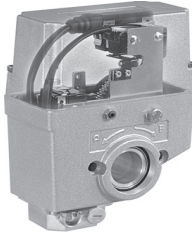
RVS	RVS ME	RVS DM	RVS ME DM
			
cod. 193312025	cod. 193312026	cod. 193312027	cod. 193312028

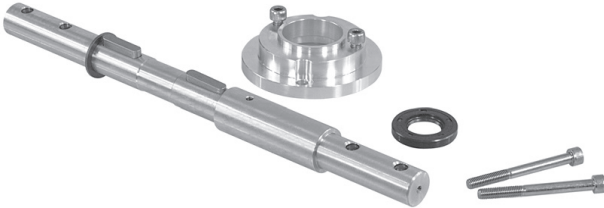
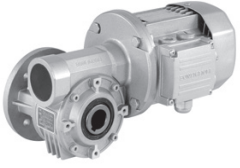
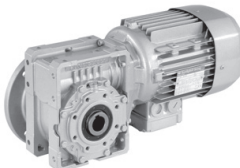
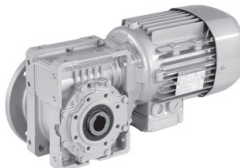
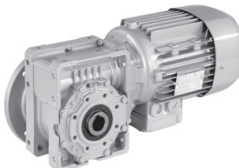

Selezionare inoltre il codice relativo al kit di configurazione per il riduttore sul quale si vuole installare il dispositivo fine-corsa:

			
cod. 192860001	cod. 192860002	cod. 192860003	cod. 192860004
			
VF 49 F - VFR 49 F	W 63 UFC - WR 63 UFC	W 75 UFC - WR 75 UFC	W 86 UFC - WR 86 UFC



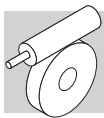

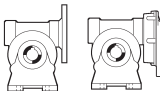

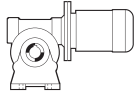

**42 TABELLE DI SELEZIONE MOTORIDUTTORE****0.12 kW**

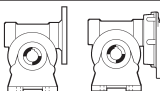
n <sub>2</sub> min <sup>-1</sup>	M <sub>2</sub> Nm	i			IEC 					
					IE1	IE2	IE3	IE1	IE2	IE3
4.7	98	300	VFR 49_300	P63	BN63A4	BE63A4	BXN63MA4			
5.8	89	240	VFR 49_240	P63	BN63A4	BE63A4	BXN63MA4			
6.7	83	210	VFR 49_210	P63	BN63A4	BE63A4	BXN63MA4			
7.8	76	180	VFR 49_180	P63	BN63A4	BE63A4	BXN63MA4			
10.4	64	135	VFR 49_135	P63	BN63A4	BE63A4	BXN63MA4			
14.0	41	100	VF 49_100	P63	BN63A4	BE63A4	BXN63MA4			
17.5	37	80	VF 49_80	P63	BN63A4	BE63A4	BXN63MA4			
20.0	34	70	VF 49_70	P63	BN63A4	BE63A4	BXN63MA4			
23.3	31	60	VF 49_60	P63	BN63A4	BE63A4	BXN63MA4			

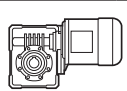

**0.18 kW**

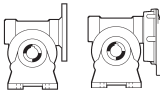
n <sub>2</sub> min <sup>-1</sup>	M <sub>2</sub> Nm	i			IEC 					
					IE1	IE2	IE3	IE1	IE2	IE3
7.8	112	180	VFR 49_180	P63	BN63B4	BE63B4	BXN63MB4			
10.4	95	135	VFR 49_135	P63	BN63B4	BE63B4	BXN63MB4			
14.0	61	100	VF 49_100	P63	BN63B4	BE63B4	BXN63MB4			
17.5	54	80	VF 49_80	P63	BN63B4	BE63B4	BXN63MB4			
20.0	49	70	VF 49_70	P63	BN63B4	BE63B4	BXN63MB4			
23.3	45	60	VF 49_60	P63	BN63B4	BE63B4	BXN63MB4			

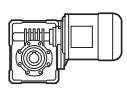
**0.25 kW**

n <sub>2</sub> min <sup>-1</sup>	M <sub>2</sub> Nm	i			IEC 					
					IE1	IE2	IE3	IE1	IE2	IE3
4.7	214	300	WR 63_300	P71	BN71A4	BE71A4	BXN71MA4			
5.8	192	240	WR 63_240	P71	BN71A4	BE71A4	BXN71MA4			
7.3	170	192	WR 63_192	P71	BN71A4	BE71A4	BXN71MA4			
10.4	136	135	WR 63_135	P71	BN71A4	BE71A4	BXN71MA4			
12.3	121	114	WR 63_114	P71	BN71A4	BE71A4	BXN71MA4			
14.0	82	100	VF 49_100	P71	BN71A4	BE71A4	BXN71MA4			
17.5	72	80	VF 49_80	P71	BN71A4	BE71A4	BXN71MA4			
20.0	66	70	VF 49_70	P71	BN71A4	BE71A4	BXN71MA4			
23.3	61	60	VF 49_60	P71	BN71A4	BE71A4	BXN71MA4			

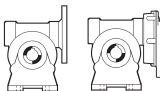
**0.37 kW**

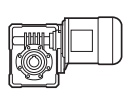
n <sub>2</sub> min <sup>-1</sup>	M <sub>2</sub> Nm	i			IEC 					
					IE1	IE2	IE3	IE1	IE2	IE3
4.7	382	300	WR 86_300	P71	BN71B4	BE71B4	BXN71MB4			
5.8	306	240	WR 75_240	P71	BN71B4	BE71B4	BXN71MB4			
7.3	290	192	WR 86_192	P71	BN71B4	BE71B4	BXN71MB4			
7.8	257	180	WR 75_180	P71	BN71B4	BE71B4	BXN71MB4			
9.3	226	150	WR 75_150	P71	BN71B4	BE71B4	BXN71MB4			
10.4	204	135	WR 63_135	P71	BN71B4	BE71B4	BXN71MB4			
12.3	181	114	WR 63_114	P71	BN71B4	BE71B4	BXN71MB4			
14.0	133	100	W 63_100	P71	BN71B4	BE71B4	BXN71MB4	S1 M1SD4	S1 ME1SB4	S10 MXN10MB4
17.5	108	80	VF 49_80	P71	BN71B4	BE71B4	BXN71MB4			
20.0	98.3	70	VF 49_70	P71	BN71B4	BE71B4	BXN71MB4			
23.3	90.5	60	VF 49_60	P71	BN71B4	BE71B4	BXN71MB4			

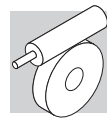

### 0.55 kW

n <sub>2</sub> min <sup>-1</sup>	M <sub>2</sub> Nm	i			IEC					
					IE1	IE2	IE3	IE1	IE2	IE3
4.7	559	300	WR 86_300	P80	BN80A4	BE80A4	BXN80MA4			
5.8	483	240	WR 86_240	P80	BN80A4	BE80A4	BXN80MA4			
7.3	423	192	WR 86_192	P80	BN80A4	BE80A4	BXN80MA4			
7.8	376	180	WR 75_180	P80	BN80A4	BE80A4	BXN80MA4			
8.3	383	168	WR 86_168	P80	BN80A4	BE80A4	BXN80MA4			
9.3	331	150	WR 75_150	P80	BN80A4	BE80A4	BXN80MA4			
10.1	330	138	WR 86_138	P80	BN80A4	BE80A4	BXN80MA4			
11.7	287	120	WR 75_120	P80	BN80A4	BE80A4	BXN80MA4			
14.0	194	100	W 63_100	P80	BN80A4	BE80A4	BXN80MA4	S1 M1LA4	S2 ME2SA4	S20 MXN20MA4
17.5	170	80	W 63_80	P80	BN80A4	BE80A4	BXN80MA4	S1 M1LA4	S2 ME2SA4	S20 MXN20MA4
21.9	148	64	W 63_64	P80	BN80A4	BE80A4	BXN80MA4	S1 M1LA4	S2 ME2SA4	S20 MXN20MA4
23.3	148	60	W 75_60	P80	BN80A4	BE80A4	BXN80MA4	S1 M1LA4	S2 ME2SA4	S20 MXN20MA4

### 0.75 kW

n <sub>2</sub> min <sup>-1</sup>	M <sub>2</sub> Nm	i			IEC					
					IE2	IE3	IE3	IE2	IE3	IE3
7.4	557	192	WR 86_192	P80	BE80B4	BX90SR4	BXN80MB4			
8.5	504	168	WR 86_168	P80	BE80B4	BX90SR4	BXN80MB4			
9.5	435	150	WR 75_150	P80	BE80B4	BX90SR4	BXN80MB4			
10.3	436	138	WR 86_138	P80	BE80B4	BX90SR4	BXN80MB4			
11.9	378	120	WR 75_120	P80	BE80B4	BX90SR4	BXN80MB4			
14.3	275	100	W 75_100	P80	BE80B4	BX90SR4	BXN80MB4	S2 ME2SB4	S2 MX2SB4	S20 MXN20MB4
17.9	236	80	W 75_80	P80	BE80B4	BX90SR4	BXN80MB4	S2 ME2SB4	S2 MX2SB4	S20 MXN20MB4
22.3	195	64	W 63_64	P80	BE80B4	BX90SR4	BXN80MB4	S2 ME2SB4	S2 MX2SB4	S20 MXN20MB4
23.8	196	60	W 75_60	P80	BE80B4	BX90SR4	BXN80MB4	S2 ME2SB4	S2 MX2SB4	S20 MXN20MB4

### 1.1 kW

n <sub>2</sub> min <sup>-1</sup>	M <sub>2</sub> Nm	i			IEC					
					IE2	IE3	IE3	IE2	IE3	IE3
10.4	643	138	WR 86_138	P90	BE90S4	BX90S4	BXN90S4			
11.9	586	120	WR 86_120	P90	BE90S4	BX90S4	BXN90S4			
14.3	437	100	W 86_100	P90	BE90S4	BX90S4	BXN90S4	S3 ME2SA4	S3 MX3SA4	
17.9	379	80	W 86_80	P90	BE90S4	BX90S4	BXN90S4	S3 ME3SA4	S3 MX3SA4	
22.3	322	64	W 86_64	P90	BE90S4	BX90S4	BXN90S4	S3 ME3SA4	S3 MX3SA4	

### 1.5 kW

n <sub>2</sub> min <sup>-1</sup>	M <sub>2</sub> Nm	i			IEC					
					IE2	IE3	IE3	IE2	IE3	IE3
11.9	792	120	WR 86_120	P90		BX90LA4				
17.9	512	80	W 86_80	P90		BX90LA4			S3 MX3SB4	
22.3	435	64	W 86_64	P90		BX90LA4			S3 MX3SB4	



**VF 49\_F - VFR 49\_F**

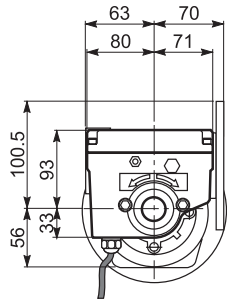

**VF 49\_F**

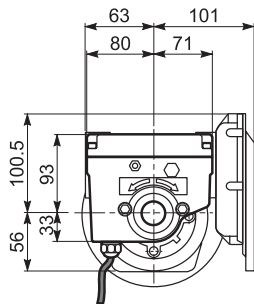
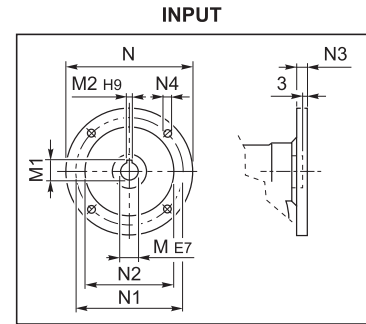
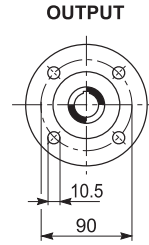
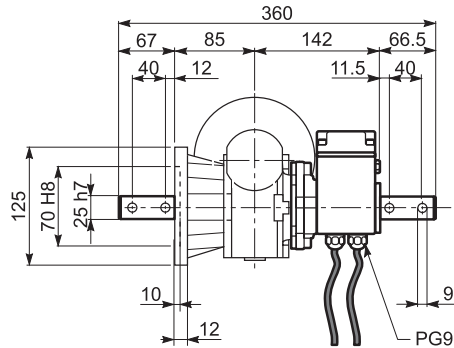

**VFR 49\_F**

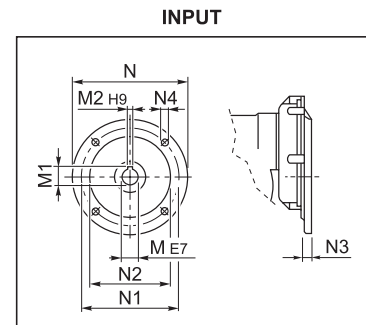
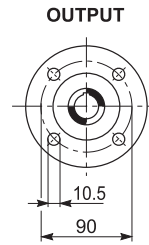
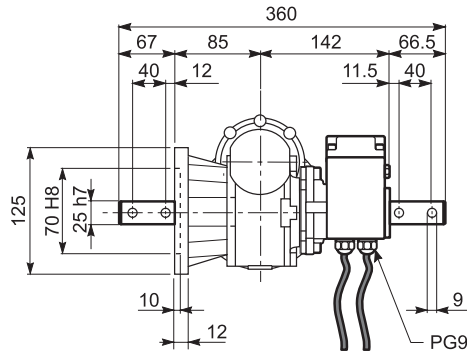

	<b>M</b>	<b>M1</b>	<b>M2</b>	<b>N</b>	<b>N1</b>	<b>N2</b>	<b>N3</b>	<b>N4</b>
<b>VF 49_P 63</b>	11	12.8	4	140	115	95	10.5	9.5
<b>VF 49_P 71</b>	14	16.3	5	160	130	110	10.5	9.5
<b>VFR 49_P 63</b>	11	12.8	4	140	115	95	11	M8x19

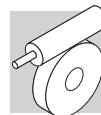

W 63 UFC\_M/ME - W 63 UFC - WR 63 UFC

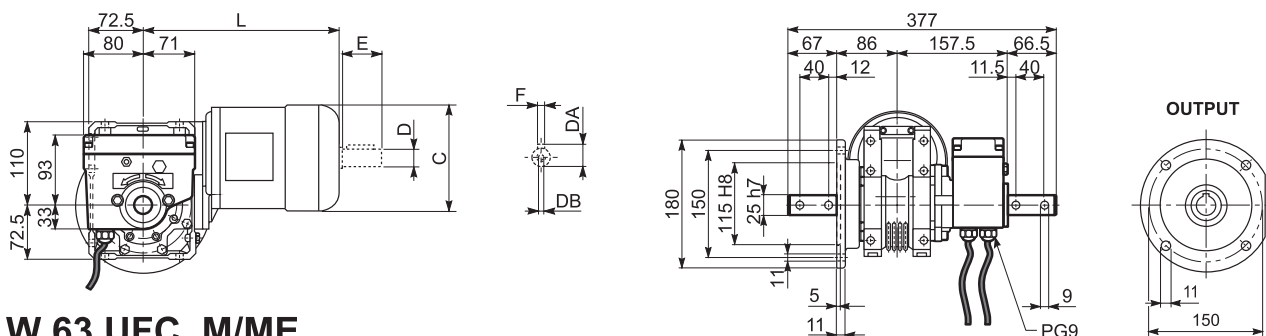

W 63 UFC\_M/ME

	C	D	DA	DB	E	F	L
W 63_S1 M1L	138	14	16	M5	30	5	289
W 63_S2 ME2S	156	19	21.5	M6	40	6	317

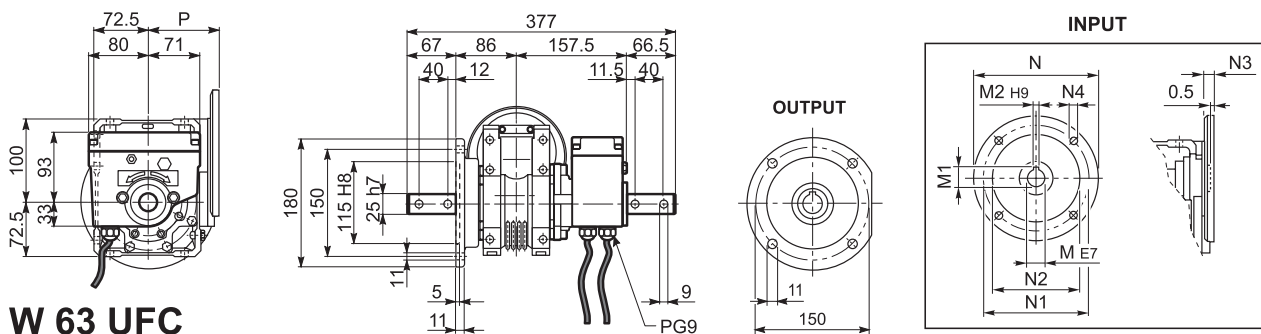

W 63 UFC

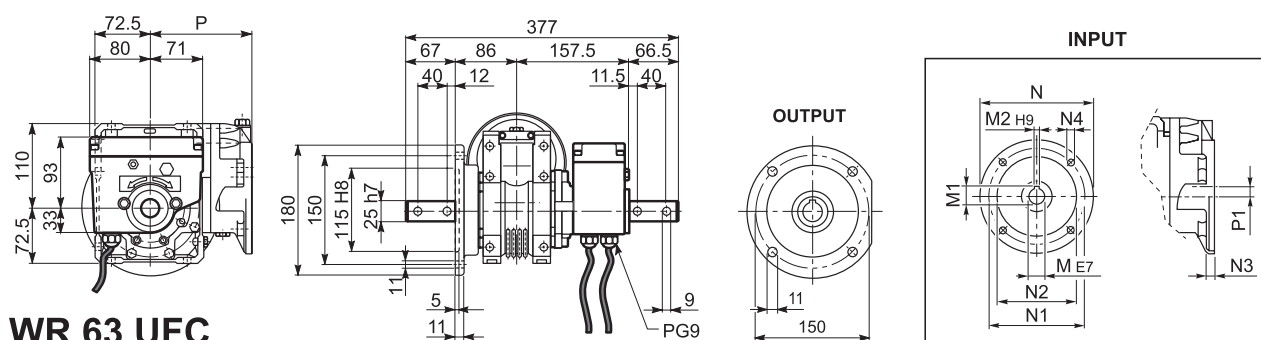

WR 63 UFC

	M	M1	M2	N	N1	N2	N3	N4	P	P1
W 63_P 71	14	16.3	5	160	130	110	11	9	95	-
W 63_P 80	19	21.8	6	200	165	130	12	11.5	102	-
W 63_P 90	24	27.3	8	200	165	130	12	11.5	102	-
WR 63_P 63	11	12.8	4	140	115	95	10	M8x10	133.5	11.42
WR 63_P 71	14	16.3	5	160	130	110	10	M8x10	133.5	11.42



**W 75 UFC\_M/ME - W 75 UFC - WR 75 UFC**

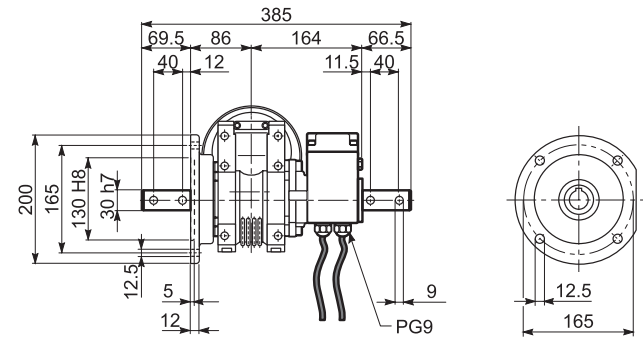
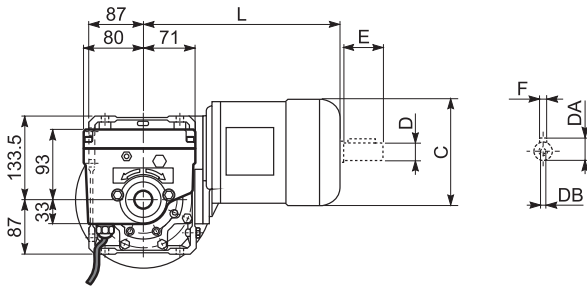

**W 75 UFC\_M/ME**

	C	D	DA	DB	E	F	L
<b>W 75_S1 M1L</b>	138	14	16	M5	30	5	308
<b>W 75_S2 ME2S</b>	156	19	21.5	M6	40	6	333
<b>W 75_S3 ME3S</b>	193	28	31	M10	60	8	376
<b>W 75_S3 ME3L</b>	193	28	31	M10	60	8	408

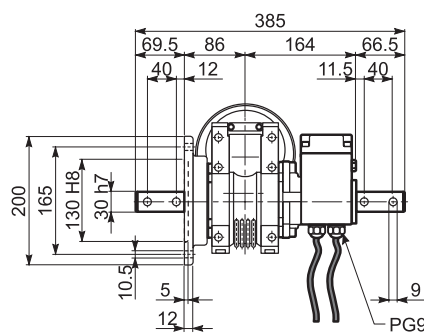
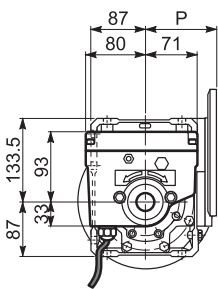

**OUTPUT**

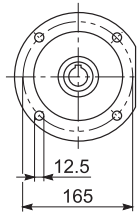

**INPUT**

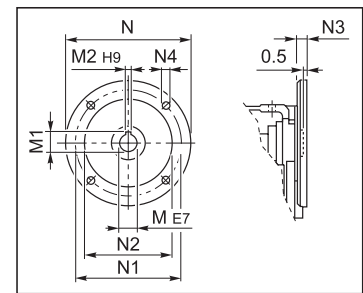

**W 75 UFC**

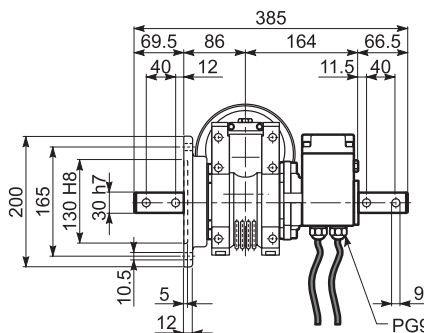
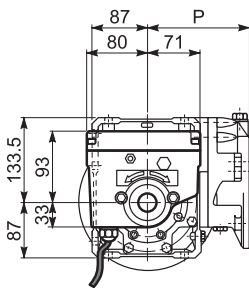

**OUTPUT**

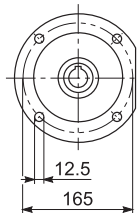

**INPUT**

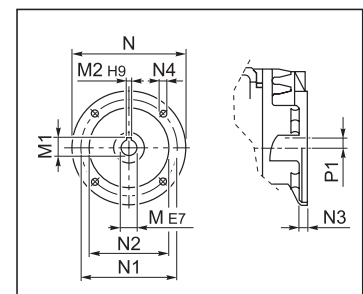

**WR 75 UFC**

	M	M1	M2	N	N1	N2	N3	N4	P	P1
<b>W 75_P 71</b>	14	16.3	5	160	130	110	11	9	112	-
<b>W 75_P 80</b>	19	21.8	6	200	165	130	12	11.5	112	-
<b>W 75_P 90</b>	24	27.3	8	200	165	130	12	11.5	112	-
<b>WR 75_P 63</b>	11	12.8	4	140	115	95	10	M8x10	152	23.53
<b>WR 75_P 71</b>	14	16.3	5	160	130	110	10	M8x10	152	23.53
<b>WR 75_P 80</b>	19	21.8	6	200	165	130	12	M10x13	163.5	11
<b>WR 75_P 90</b>	24	27.3	8	200	165	130	12	M10x13	163.5	11

**W 86 UFC\_M/ME - W 86 UFC - WR 86 UFC**

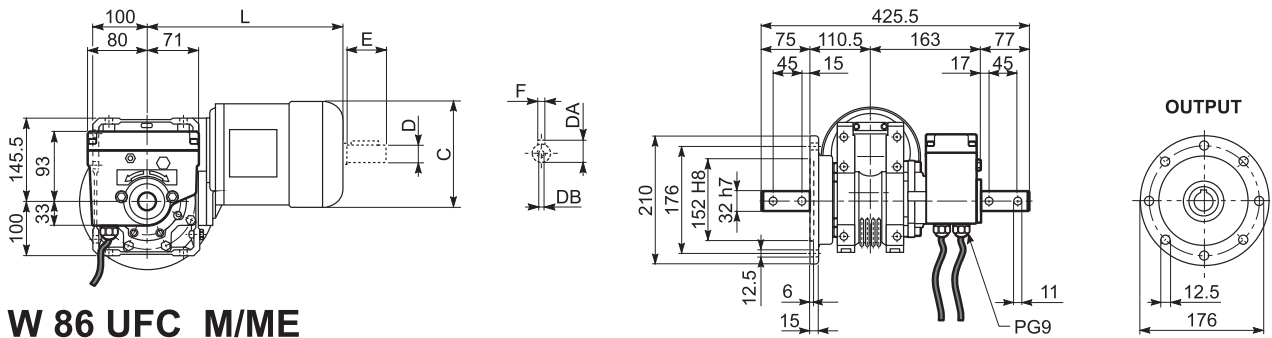

**W 86 UFC\_M/ME**

	C	D	DA	DB	E	F	L
<b>W 86_S1 M1L</b>	138	14	16	M5	30	5	324
<b>W 86_S2 ME2S</b>	156	19	21.5	M6	40	6	349
<b>W 86_S3 ME3S</b>	193	28	31	M10	60	8	392
<b>W 86_S3 ME3L</b>	193	28	31	M10	60	8	424

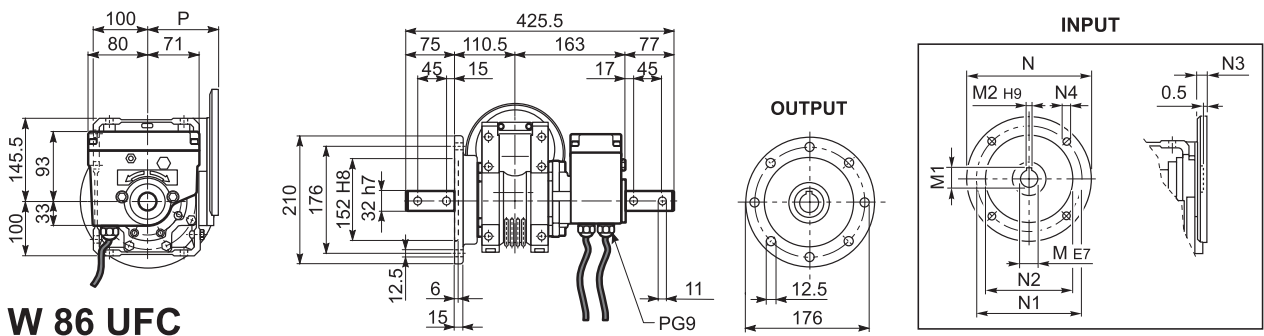

**W 86 UFC**

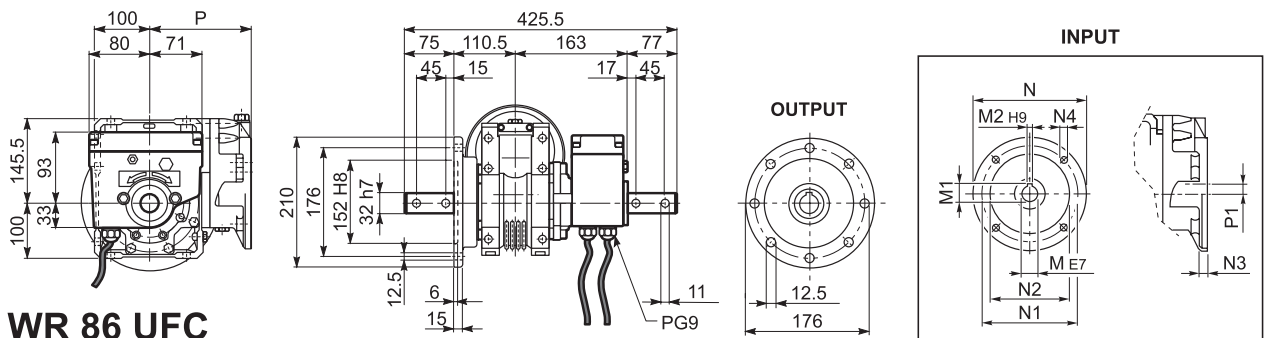

**WR 86 UFC**

	M	M1	M2	N	N1	N2	N3	N4	P	P1
<b>W 86_P 71</b>	14	16.3	5	160	130	110	11	9	128	-
<b>W 86_P 80</b>	19	21.8	6	200	165	130	12	11.5	128	-
<b>W 86_P 90</b>	24	27.3	8	200	165	130	12	11.5	128	-
<b>WR 86_P 63</b>	11	12.8	4	140	115	95	10	M8x10	168	35.4
<b>WR 86_P 71</b>	14	16.3	5	160	130	110	10	M8x10	168	35.4
<b>WR 86_P 80</b>	19	21.8	6	200	165	130	12	M10x13	179.5	22.9
<b>WR 86_P 90</b>	24	27.3	8	200	165	130	12	M10x13	179.5	22.9



**Varianti fine corsa**

**ME**

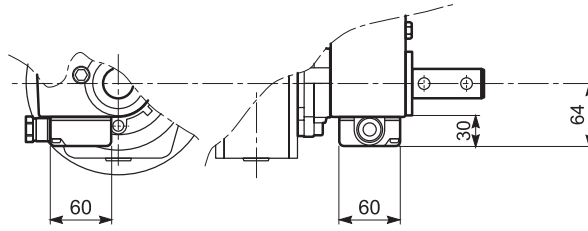

Versione con morsettiera

**DM**

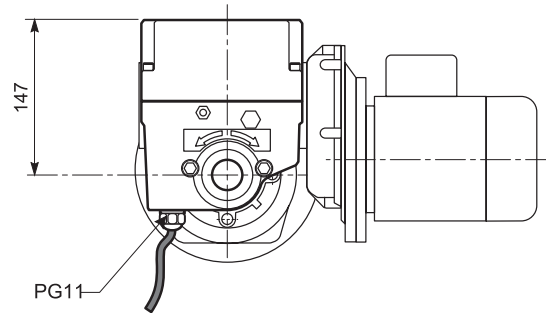

Versione con doppi micro



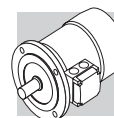

## MOTORI ELETTRICI

### M1 SIMBOLOGIA E UNITÀ DI MISURA

Simbolo	Unità di misura	Descrizione	Simbolo	Unità di misura	Descrizione
$\cos\varphi$	–	Fattore di potenza	$n$	$[\text{min}^{-1}]$	Velocità nominale
$\eta$	–	Rendimento	$P_B$	[W]	Potenza assorbita dal freno a 20°C
$f_m$	–	Fattore correttivo della potenza	$P_n$	[kW]	Potenza nominale
$I$	–	Rapporto di intermittenza	$P_r$	[kW]	Potenza richiesta
$I_N$	[A]	Corrente nominale	$t_1$	[ms]	Ritardo di sblocco del freno con alimentatore a semionda
$I_S$	[A]	Corrente di spunto	$t_{1s}$	[ms]	Tempo di sblocco del freno con alimentatore a controllo elettronico
$J_C$	[Kgm <sup>2</sup> ]	Momento di inerzia del carico	$t_2$	[ms]	Ritardo di frenatura con disgiunzione lato c.a.
$J_M$	[Kgm <sup>2</sup> ]	Momento di inerzia motore	$t_{2c}$	[ms]	Ritardo di frenatura con disgiunzione circuito c.a. e c.c.
$K_C$	–	Fattore di coppia	$t_a$	[°C]	Temperatura ambiente
$K_d$	–	Fattore di carico	$t_f$	[min]	Tempo di funzionamento a carico costante
$K_J$	–	Fattore di inerzia	$t_r$	[min]	Tempo di riposo
$M_A$	[Nm]	Coppia accelerante media	$W$	[J]	Lavoro di frenatura accumulato tra due regolazioni del traferro
$M_B$	[Nm]	Coppia frenante	$W_{\max}$	[J]	Energia massima per singola frenatura
$M_N$	[Nm]	Coppia nominale	$Z$	[1/h]	N° di avviamenti ammissibili, a carico
$M_L$	[Nm]	Coppia resistente media	$Z_0$	[1/h]	N° di avviamenti ammissibili a vuoto ( $I = 50\%$ )
$M_S$	[Nm]	Coppia di spunto			



## M2 INTRODUZIONE

### Classi di rendimento e metodo di prova

Il rendimento descrive l'efficienza con la quale il motore elettrico trasforma l'energia elettrica in meccanica.

In Europa il sistema di classificazione energetica dei motori in bassa tensione avveniva su base volontaria con riferimento alle classi Eff1/Eff2/Eff3; altri paesi si riferivano ai propri sistemi nazionali spesso molto diversi da quello Europeo.

Questa incertezza normativa ha spinto i costruttori a promuovere un'armonizzazione internazionale e l'emissione della Norma IEC (International Electrotechnical Commission) IEC 60034-30-1, "Classi di rendimento dei motori asincroni trifase a gabbia ad una sola velocità (codice IE)".

La nuova Norma:

- definisce le nuove classi di efficienza

**IE1** (rendimento standard)

**IE2** (alto rendimento)

**IE3** (rendimento premium)

- fornisce un riferimento comune internazionale per la classificazione dei motori elettrici come pure per le attività legislative nazionale

- introduce il nuovo metodo di misura del rendimento in accordo alla Norma IEC 60034-1-2:2007

Nella tabella seguente è evidenziata la corrispondenza tra le principali classificazioni.

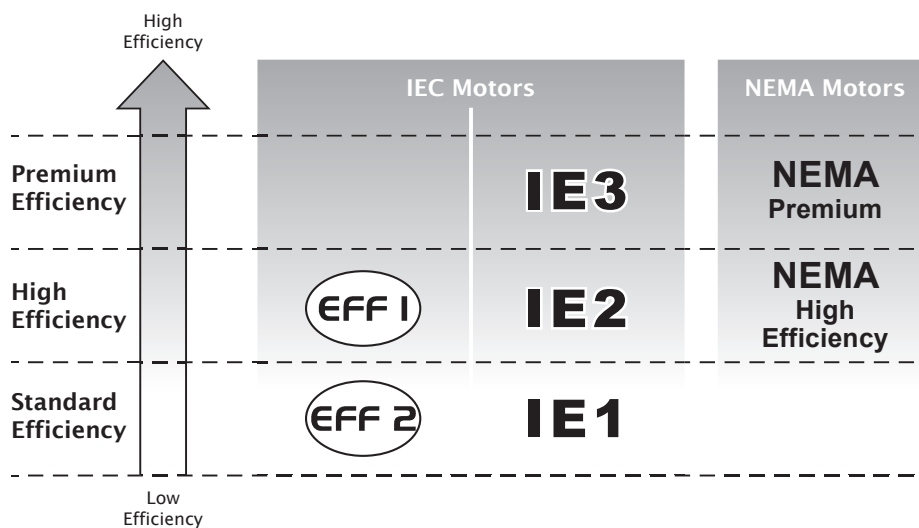



### Regolamento CE N° 640/2009 della Commissione

La Norma IEC 60034-30-1 fornisce le linee guida tecniche ma non stabilisce in termini legali i requisiti richiesti per l'adozione di una certa classe di rendimento; questi requisiti sono specificati dalle Direttive e dalle Leggi nazionali.

Il regolamento di applicazione della Direttiva 2005/32/CE, adottato il 22 Luglio 2009, stabilisce questi requisiti e specifica i criteri per la progettazione ecocompatibile dei motori elettrici, fissando i limiti di rendimento secondo le seguenti scadenze:

- **16/06/2011**: I motori elettrici devono avere un livello minimo di efficienza corrispondente a **IE2**
- **01/01/2015**: I motori elettrici con una potenza nominale compresa tra 7.5 kW e 375 kW devono avere un livello minimo di efficienza corrispondente a **IE3**, oppure a **IE2** se dotati di un convertitore di frequenza.
- **01/01/2017**: I motori elettrici con una potenza nominale compresa tra 0.75 kW e 375 kW devono avere un livello minimo di efficienza corrispondente a **IE3**, oppure a **IE2** se dotati di un convertitore di frequenza.

### Scopo ed esclusioni

Il Regolamento (CE) N. 640/2009 si applica ai motori a induzione, a gabbia di scoiattolo a 2, 4 e 6 poli, singola velocità, trifase 50 Hz o 60 Hz, con potenza output tra 0.75 kW a 375 kW, tensione nominale fino a 1000 V, e che abbiano caratteristiche basate su di un funzionamento continuo (S1).

Sono esclusi dall'applicazione di questo regolamento:

- I motori autofrenanti.
- I motori progettati per funzionare completamente immersi in un liquido.
- I motori completamente integrati in un prodotto (ad esempio riduttore, pompe, ventilatori), rendendo impossibile testarne le prestazioni in modo indipendente dal prodotto.
- I motori espressamente progettati per funzionare:
  - ad altitudini superiori a 4000 metri slm;
  - dove la temperatura ambiente supera i 60 °C;
  - a temperature massime di esercizio superiori a 400 °C;
  - dove la temperatura ambiente è inferiore a -30 °C (qualsiasi motore) o inferiore a 0 °C (per i motori raffreddati ad acqua);
  - dove la temperatura del liquido refrigerante in entrata è inferiore a 0 °C o supera i 32 °C;
  - in atmosfere potenzialmente esplosive come definite dalla direttiva 2014/34/UE.

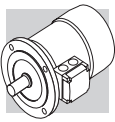

## M3 CARATTERISTICHE GENERALI

### M3.1 Programma di produzione

I motori elettrici asincroni trifase BXN, BX, BE, BN, MXN, MX, ME e M del programma di produzione della BONFIGLIOLI RIDUTTORI sono previsti nella forma costruttiva base IMB5 e derivate. I motori sono del tipo chiuso con ventilazione esterna e rotore a gabbia per l'utilizzo in ambienti industriali. I motori BX, BE, MX, ME sono previsti, nell'esecuzione standard, per tensione nominale 230/400V  $\Delta/Y$  (400/690V  $\Delta/Y$  per le grandezze BX-BE 160 e BX-BE 180) 50 Hz con tolleranza  $\pm 10\%$ . I motori BN/M sono previsti, nell'esecuzione standard, per tensione nominale 230/400V  $\Delta/Y$  (400/690V  $\Delta/Y$  per le grandezze BN 160 ... BN 200) 50 Hz con tolleranza  $\pm 10\%$ .

Sui motori BXN/MXN è presente una morsettiera con connessione a 9 PIN + avvolgimento a 12 fili che rende facile ottenere come standard la giusta tensione per la maggior parte dei paesi. La versione Standard è identificata come WD1 e permette di ottenere le seguenti tensioni/frequenze (115/200/230/400V-50Hz e 132/230/265/460V-60Hz). Per i motori BXN/MXN la tolleranza di tensione è ridotta a  $\pm 5\%$ .

### M3.2 Normative

I motori descritti in questo catalogo sono costruiti in accordo alle Norme ed unificazioni applicabili evidenziate nella tabella seguente.

(F01)	Titolo	CEI	IEC
	Prescrizioni generali per macchine elettriche rotanti	CEI EN 60034-1	IEC 60034-1
	Marcatura dei terminali e senso di rotazione per macchine elettriche rotanti	CEI 2-8	IEC 60034-8
	Metodi di raffreddamento delle macchine elettriche	CEI EN 60034-6	IEC 60034-6
	Dimensioni e potenze nominali per macchine elettriche rotanti	EN 50347	IEC 60072
	Classificazione dei gradi di protezione delle macchine elettriche rotanti	CEI EN 60034-5	IEC 60034-5
	Limiti di rumorosità	CEI EN 60034-9	IEC 60034-9
	Sigle di designazione delle forme costruttive e dei tipi di installazione	CEI EN 60034-7	IEC 60034-7
	Tensione nominale per i sistemi di distribuzione pubblica dell'energia elettrica a bassa tensione	CEI 8-6	IEC 60038
	Grado di vibrazione delle macchine elettriche	CEI EN 60034-14	IEC 60034-14
	Classi di rendimento dei motori asincroni trifase con rotore a gabbia ad una sola velocità (Codice IE)	CEI EN 60034-30-1	IEC 60034-30-1
	Metodi normalizzati per la determinazione, mediante prove, delle perdite e del rendimento	CEI EN 60034-2-1	IEC 60034-2-1

I motori corrispondono inoltre alle Norme straniere adeguate alle IEC 60034-1 e qui riportate.

(F02)	DIN VDE 0530	Germania
	BS5000 / BS4999	Gran Bretagna
	AS 1359	Australia
	NBNC 51 - 101	Belgio
	NEK - IEC 34	Norvegia
	NF C 51	Francia
	OEVE M 10	Austria
	SEV 3009	Svizzera
	NEN 3173	Paesi Bassi
	SS 426 01 01	Svezia



### M3.3 Direttive 2006/95/CE (LVD) e 2004/108/CE (EMC)

I motori BXN, BX, BE, BN, MXN, MX, ME e M soddisfano i requisiti delle Direttive 2014/35/UE (LVD - Direttiva Bassa Tensione), 2014/30/UE (EMC - Direttiva Compatibilità Elettromagnetica), 2009/125/CE (ERP - Direttiva sui prodotti correlati all'energia) e 2011/65/UE (RoHS - Restriction of Hazardous Substances) e le loro targhette portano il marchio CE.

Per quanto riguarda la Direttiva EMC, la costruzione è conforme alle norme CEI EN 60034-1 (Macchine elettriche rotanti Parte 1: Potenza e prestazioni), CEI EN 61000-6-2 (Norme generiche - Immunità per ambienti industriali), CEI EN 61000-6-4 (Norme generiche - Norma di emissione per ambienti industriali).

I motori con freno FD, se dotati dell'apposito filtro capacitivo all'ingresso del raddrizzatore (opzione **CF**), soddisfano i limiti di emissione previsti dalle Norme CEI EN 61000-6-3 e CEI EN 60204-1.

La responsabilità della sicurezza del prodotto finale e della conformità alle direttive applicabili spetta al produttore o all'assemblatore che incorporano i motori come componenti.

#### Il marchio standard UKCA

Nel Regno Unito il marchio CE sarà sostituito dal marchio UKCA (United Kingdom Conformity Assessed mark), a causa della Brexit, a partire dal 1 gennaio 2022. Tutti I motori Bonfiglioli sono già conformi ai requisiti UKCA.

### M3.4 Direttiva Europea 2012/19/UE - Informazioni sullo smaltimento



Questo prodotto non può essere smaltito come rifiuto urbano. Laddove lo smaltimento è a cura dell'utilizzatore, assicurarsi che esso sia effettuato, ove previsto, conformemente alla Direttiva Europea 2012/19/UE, nonché alle relative norme di recepimento nazionali. Adempiere allo smaltimento conformemente a qualsiasi altra normativa in tema, vigente sul territorio nazionale.

### M3.5 Tolleranze

Secondo le Norme CEI EN 60034-1, per le grandezze garantite sono ammesse le tolleranze qui indicate:

(F03)	$-0.15 (1 - \eta) \quad P \leq 50\text{kW}$	Rendimento
	$-(1 - \cos\phi)/6 \quad \text{min } 0.02 \quad \text{max } 0.07$	Fattore di potenza
	$\pm 20\% \quad *$	Scorrimento
	+20%	Corrente a rotore bloccato
	-15% +25%	Coppia a rotore bloccato
	-10%	Coppia max

\*  $\pm 30\%$  per motori con  $P_n < 1 \text{ kW}$



**M4 DESIGNAZIONE MOTORE**

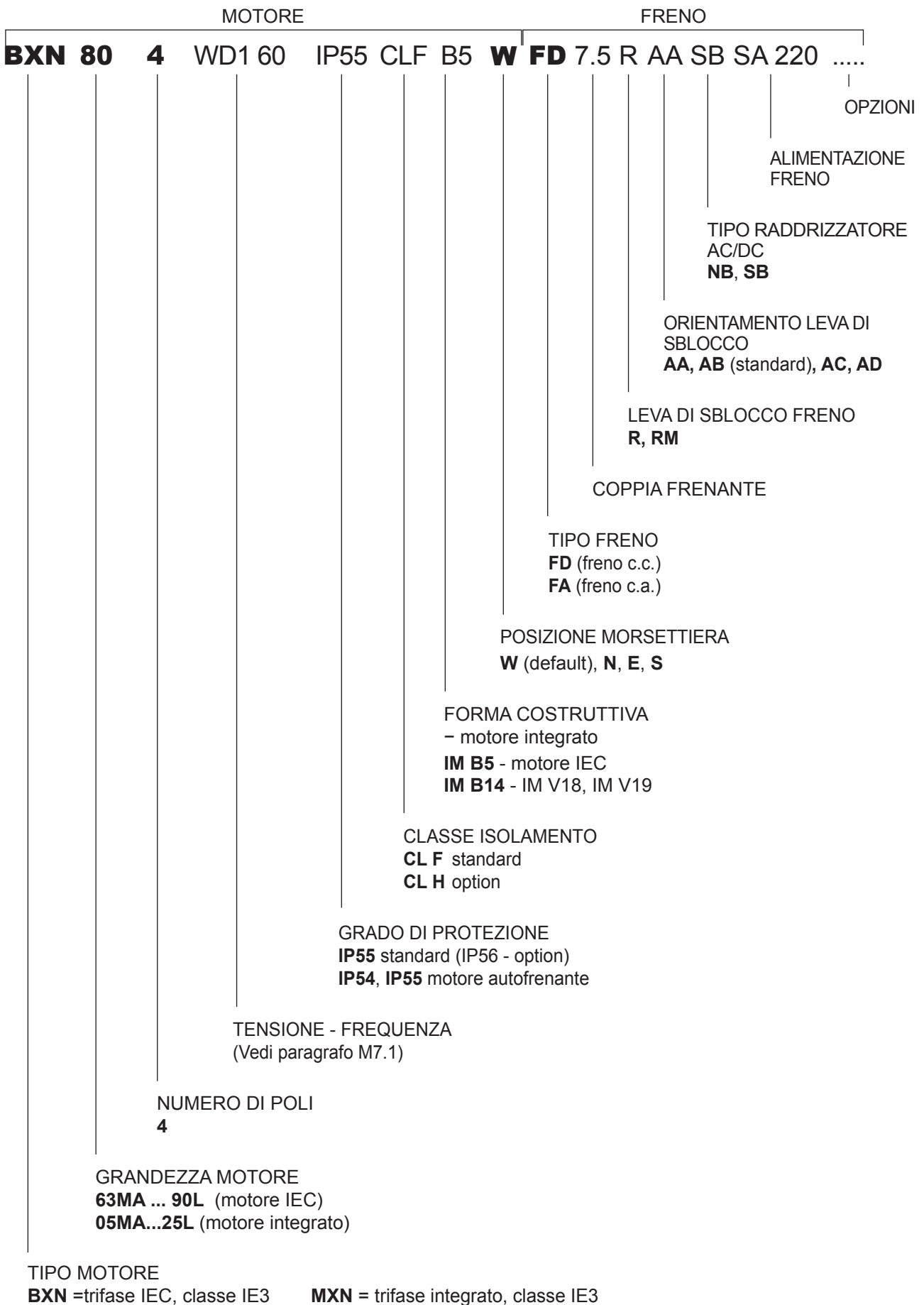



## MOTORE

## FRENO

**BX 132SB 4** 230/400-50 IP55 CLF B5 **W FD** 7.5 R AA SB SA 220 .....

OPZIONI

ALIMENTAZIONE  
FRENOTIPO RADDRIZZATORE  
AC/DC  
**NB, SB, NBR, SBR**ORIENTAMENTO LEVA DI  
SBLOCCO  
**AA, AB** (standard), **AC, AD**LEVA DI SBLOCCO FRENO  
**R, RM**

COPPIA FRENANTE

TIPO FRENO  
**FD** (freno c.c.)  
**FA** (freno c.a.)POSIZIONE MORSETTIERA  
(solo motore integrato)  
**W** (default), **N, E, S**FORMA COSTRUTTIVA  
- motore integrato  
**IM B5** - motore IEC  
**IM B14** - IM V18, IM V19CLASSE ISOLAMENTO  
**CL F** standard  
**CL H** optionGRADO DI PROTEZIONE  
**IP55** standard (IP56 - option)  
**IP54, IP55** motore autofrenanteTENSIONE - FREQUENZA  
(Vedi paragrafo M7.1)NUMERO DI POLI  
**4**GRANDEZZA MOTORE  
**80B ... 355** (motore IEC)  
**2SB ... 5LA** (motore integrato)

TIPO MOTORE

**BX** = trifase IEC, classe IE3**MX** = trifase integrato, classe IE3



## MOTORE

## FRENO

**BE 90LA 4 230/400-50 IP55 CLF B5 W FD 7.5 R AA SB SA 220 .....**

OPZIONI

ALIMENTAZIONE  
FRENOTIPO RADDRIZZATORE  
AC/DC  
**NB, SB, NBR, SBR**ORIENTAMENTO LEVA DI  
SBLOCCO  
**AA, AB** (standard), **AC, AD**LEVA DI SBLOCCO FRENO  
**R, RM**

COPPIA FRENANTE

TIPO FRENO  
**FD** (freno c.c.)  
**FA** (freno c.a.)POSIZIONE MORSETTIERA  
(solo motore integrato)  
**W** (default), **N, E, S**FORMA COSTRUTTIVA  
- motore integrato  
**IM B5** - motore IEC  
**IM B14** - IM V18, IM V19CLASSE ISOLAMENTO  
**CL F** standard  
**CL H** optionGRADO DI PROTEZIONE  
**IP55** standard (IP56 - option)  
**IP54, IP55** motore autofrenanteTENSIONE - FREQUENZA  
(Vedi paragrafo M7.1)NUMERO DI POLI  
**2, 4, 6**GRANDEZZA MOTORE  
**63A ... 180L** (motore IEC)  
**05A ... 5L** (motore integrato)

TIPO MOTORE

**BE** = trifase IEC, classe IE2     **ME** = trifase integrato, classe IE2





MOTORE

FRENO

**BN 90LA 4** 230/400-50 IP55 CLF B5 **W** **FD** 7.5 R AA SB SA 220 .....

OPZIONI

ALIMENTAZIONE  
FRENO

TIPO RADDRIZZATORE  
AC/DC  
**NB, SB, NBR, SBR**

ORIENTAMENTO LEVA DI  
SBLOCCO  
**AA, AB** (standard), **AC, AD**

LEVA DI SBLOCCO FRENO  
**R, RM**

COPPIA FRENANTE

TIPO FRENO  
**FD** (freno c.c.)  
**FA** (freno c.a.)

POSIZIONE MORSETTIERA  
(solo motore integrato)  
**W** (default), **N, E, S**

FORMA COSTRUTTIVA  
- motore integrato  
**IM B5** - motore IEC  
**IM B14** - IM V18, IM V19

CLASSE ISOLAMENTO  
**CL F** standard  
**CL H** option

GRADO DI PROTEZIONE  
**IP55** standard (IP56 - option)  
**IP54, IP55** motore autofrenante

TENSIONE - FREQUENZA  
(Vedi paragrafo M7.1)

NUMERO DI POLI  
**2, 4, 6, 2/4, 2/6, 2/8, 2/12, 4/6, 4/8**

GRANDEZZA MOTORE  
**56A ... 200LA** (motore IEC)  
**0B ... 5SB** (motore integrato)

TIPO MOTORE

**BN** = trifase IEC    **M** = trifase integrato IEC



## M5 VARIANTI E OPZIONI

### M5.1 Varianti

(F04)

Descrizione		Default	Opzione	Pagina
Tensione (BN - BE - BX) ≤ 132		230/400/50		232
Tensione (BN - BE - BX) ≥ 160		400/690/50		
Tensione (BXN)		WD1		EVOX*
Grado di protezione	BXN - BX - BE - BN - MXN - MX - ME - M	IP 55	IP 56	228
	BXN - BX - BE - BN/FA-FD MXN - MX - ME - M/FA-FD	IP 54	IP 55	
	BX_FD ≥ 200	IP 55		
	BX...K - BX... K_FDK	IP 55	IP 56	
Classe di isolamento		CLF	CLH	239
Forma costruttiva	BX - BE - BN	<b>B5</b> <b>B5 R</b>	<b>B14</b> <b>B14 R</b>	227
	BXN	<b>B5</b>	<b>B14</b>	EVOX*

Valori pre-impostati di default. \* Consultare lo specifico catalogo EVOX

### M5.2 Opzioni

(F05)

Descrizione	Valori								Disponibilità	Pagina
	D3	K1	E3	PT1000°°						
Protezioni termiche	D3	K1	E3	PT1000°°					BXN-BX-BE-BN-MXN-MX-ME-M	257-258
Potenza normalizzata a 50 Hz	PN								BN - M	235
Dispositivi di retroazione	EN1	EN2	EN3	EN4	EN5	EN6	EN7*	EN8*	BXN-BX-BE-BN-MX-ME-M	267
Riscaldatori anticondensa	H1	NH1							BXN-BX-BE-BN-MXN-MX-ME-M	261
Tropicalizzazione avvolgimenti	TP								BXN-BX-BE-BN-MXN-MX-ME-M	262
Doppia estremità d'albero	PS								BXN-BX-BE-BN-MXN-MX-ME-M	262
Equilibratura rotore in grado B	RV								BX - BE - BN MX - ME - M	263
Protezioni meccaniche esterne	RC	TC***	EC°°						BXN-BX-BE-BN-MXN-MX-ME-M	265-268
Ventilazione forzata	U1	U2**							BX - BE - BN MX - ME - M	264-265
Cuscinetti isolati	IB*								BX - MX	269
Certificazione CSA/UL	CUS°								BXN-BX-BE-BN-MXN-MX-ME-M	236
Motori Certificati per il mercato Indiano	BIS								BE - ME	237
China Compulsory Certification	CCC								BX - BE - BN MX - ME - M	237
Motori Certificati per il mercato Cinese (China Energy Label)	CEL								BX - MX	237
Motori certificati per il mercato Brasiliano	NBR								BX - MX	238
Motori certificati per il mercato Australiano	EECA								BX - MX	238
Motore con connettore	CON								BX - BE - BN MX - ME - M	239
Protezione superficiale	C_								BXN-BX-BE-BN-MXN-MX-ME-M	258
Verniciatura	RAL								BXN-BX-BE-BN-MXN-MX-ME-M	269
Prove documenti	ACM								BXN-BX-BE-BN-MXN-MX-ME-M	270
Certificato di collaudo	CC								BXN-BX-BE-BN-MXN-MX-ME-M	270
Montaggio verticale	VM*								BX - MX	270
Dispositivo antiritorno	AL	AR							MX - ME - M	263
Tipo di servizio	S2	S3	S9						BN - M	240
	S2-10	S2-30	S2-60	S3=25%	S3=40%	S3=70%			BXN - MXN	

\*Solo per BX ≥ 280 and BX ≥ 280K

\*\* Solo per motori BN

\*\*\* Non per motori BX - MX

° Standard on BXN/MXN not an option

°° Solo per motori BXN/MXN



### M5.3 Opzioni collegate al freno

(F06)	Descrizione	Valori				Disponibilità	Pagina
	Coppia frenante	Riferirsi al particolare tipo di freno					249-252
	Leva di sblocco manuale	<b>R</b>	<b>RM</b>			BXN - BX - BE - BN MXN - MX - ME - M	255
	Orientamento leva di sblocco	<b>AB</b>	<b>AA</b>	<b>AC</b>	<b>AD</b>	BXN - BX - BE - BN MXN - MX - ME - M	256
	Alimentatore freno d.c	<b>NB</b>	<b>NBR°</b>	<b>SB</b>	<b>SBR°</b>	BXN - BX - BE - BN MXN - MX - ME - M	248
	Volano per avviamento progressivo	<b>F1</b>				BE - BN ME - M	257
	Filtro capacitivo	<b>CF</b>				BXN - BX - BE - BN MXN - MX - ME - M	257
	Alimentazione freno separata (*)	<b>...SA</b>	<b>...SD</b>	<b>DIR°°</b>		BXN - BX - BE - BN MXN - MX - ME - M	256
	Controllo della funzionalità del freno	<b>MSW</b>				BX - BE - BN MX - ME - M	261
	Ingresso cavi supplementare per motori autofrenanti	<b>IC</b>				BN M	261

(\*) Completare con il valore di tensione. (°) Non per BXN/MXN (°°) Solo per motori BXN/MXN - significa "senza alimentazione separata"

■ Default values.

### M5.4 Esempio di targhetta identificativa per i motori legacy (BX - BE - BN)

IEC EN 60034		<b>Bonfiglioli</b> Riduttori		CE	
3~Mot BE 90LA 4		Cod. 8U09030001			
No 1003001 - 6954785		S1 IM B5 15,1 kg			
kW 1,5		CL F IP 55 Amb 40 °C			
Hz	V ± 10%	A	min <sup>-1</sup>	cos φ	
50	230/400 Δ/Y	6,1/3,5	1430	0,74	
60	265/460 Δ/Y	5,4/3,1	1730	0,73	
50Hz-IE2		83.5(100%) - 83.0(75%) - 80.0(50%)			
60Hz-IE2		84.5(100%) - 83.9(75%) - 80.7(50%)			

- ① Identificativo motore BONFIGLIOLI
- ② Numero di serie
- ③ Tensione nominale
- ④ Codice motore
- ⑤ Tipo di servizio: S1 servizio continuo
- ⑥ Classe di efficienza IE a: 4/4 - 3/4 - 2/4 del carico



### M5.4.1 Esempio di targhetta identificativa per i motori EVOX (BXN)

1	<b>Bonfiglioli</b>				
	3~Mot BXN 90L 4 FD		TEFC IMB14 IP55 22,6 kg		
2	Cod. xxxxxxxxxxxx		No xxxxxxxx - xxxxxxxx		
	kW 1,5 HP 2		Amb 40 °C CLF S1		
3	Hz	V	A	min <sup>-1</sup>	cos φ
	50	115/200 ΔΔ/Y	11.9/6.88	1441	0.75
	50	230/400 Δ/Y	5.96/3.44	1441	0.75
4	60	132/230 ΔΔ/Y	10.1/5.84	1750	0.74
	60	265/460 Δ/Y	5.6/2.92	1750	0.74
5	60Hz IE3 - 85.3 (100%) 84.3 (75%) 81.7 (50%) - KVA code J				
	40Hz IE3 - 86.5 (100%) 86.5 (75%) 83.4 (50%) - KVA code L				
6	H1 1~ 230V ± 10% 10W				
7	VB = 230V MB = 26Nm NB SA				
8					
	Bonfiglioli Riduttori S.p.A.		Made in Italy		
				9	10

- ① Designazione motori e informazioni generali
- ② Codici seriali
- ③ Conformità ambientali e alle applicazioni
- ④ Prestazioni nominali in funzione di tensioni/frequenze
- ⑤ Prestazioni del motore @ 50 Hz
- ⑥ Prestazioni del motore @ 60 Hz
- ⑦ Informazioni sulla protezione termica e sulla servoventilazione
- ⑧ Informazioni sul freno
- ⑨ Certificazioni
- ⑩ Informazioni sul fabbricante

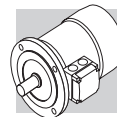

## M6 CARATTERISTICHE MECCANICHE

### M6.1 Forme costruttive

I motori serie BXN, BX, BE e BN sono previsti nelle forme costruttive indicate nella tabella seguente secondo le Norme CEI EN 60034-7 (BX/BE), CEI EN 60034-14 (BN).

Le forme costruttive sono le seguenti:

**IM B5** (base)

IM V1, IM V3 (derivate)

**IM B14** (base)

IM V18, IMV19 (derivate)

I motori in forma costruttiva IM B5 possono essere installati nelle posizioni IM V1 e IM V3; i motori in forma costruttiva IM B14 possono essere installati nelle posizioni IM V18 e IM V19.

In questi casi, sulla targa del motore sarà indicata la forma costruttiva base IM B5 o IM B14.

Nelle forme costruttive dove il motore assume una posizione verticale con albero in basso, si consiglia di richiedere l'esecuzione con tettuccio parapioggia (da prevedere sempre nel caso di motori autofrenanti).

Tale esecuzione, presente nelle opzioni, va richiesta espressamente in fase di ordine in quanto non è prevista nella versione base.

(F07)

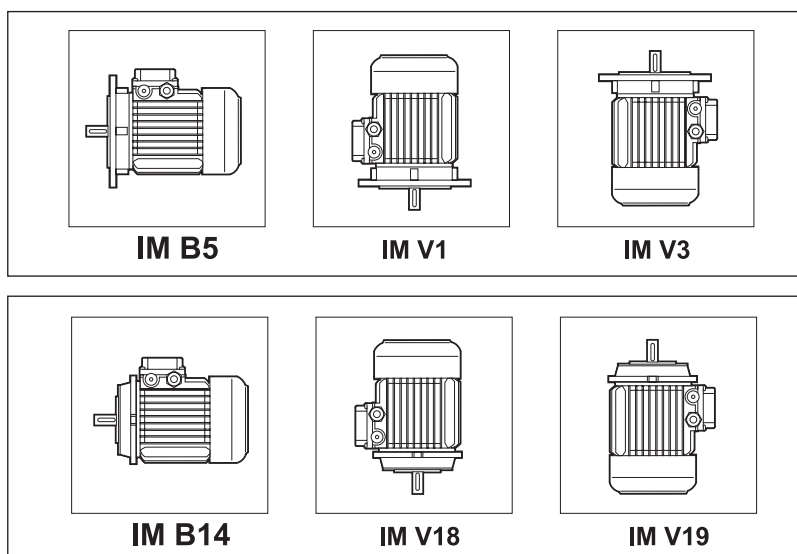

**Per i motori BX $\geq$ 200 e BX $\geq$ 200K** quando montati in verticale occorre selezionare l'opzione VM.

Nelle forme costruttive dove il motore assume una posizione verticale con albero in basso, si consiglia di richiedere l'esecuzione con tettuccio parapioggia (RC). Tale esecuzione, presente nelle opzioni, va richiesta espressamente in fase di ordine in quanto non è prevista nella versione base.

I motori in forma flangiata possono essere forniti con dimensioni di accoppiamento ridotte, come riportato nella tabella seguente - esecuzioni **B5R, B14R**. Il loro utilizzo in abbinamento ai riduttori dovrà in ogni caso risultare coerente con la massima potenza installabile sui riduttori stessi (vedere i capitoli "Predisposizioni motori"). Nei casi in cui non sia rispettata questa condizione occorre contattare il Servizio Tecnico per la verifica dell'abbinamento.



(F08)

	<b>BN/BE</b> 71	<b>BX/BE/BN</b> 80	<b>BX/BE/BN</b> 90	<b>BX/BE/BN</b> 100	<b>BX/BE/BN</b> 112	<b>BX/BE/BN</b> 132
	DxE - Ø					
<b>B5R</b> <sup>(1)</sup>	11x23 - 140	14x30 - 160	19x40 - 200	24x50 - 200	24x50 - 200	28x60 - 250
<b>B14R</b> <sup>(2)</sup>	11x23 - 90	14x30 - 105	19x40 - 120	24x50 - 140	—	—

(1) flangia con fori passanti

(2) flangia con fori filettati

## M6.2 Grado di protezione

**IP..**

La tabella sottostante riassume la disponibilità dei vari gradi di protezione.























Indipendentemente dal grado di protezione specificato, per installazione all'aperto i motori devono essere protetti dall'irraggiamento diretto e, nel caso d'installazione con albero rivolto verso il basso, è necessario specificare ulteriormente il tettuccio di protezione contro l'ingresso di acqua e corpi solidi (opzione **RC**).

(F09)

		IP 54	IP 55	IP 56
<b>BXN- BX-BE-BN</b>	<b>MXN-MX-ME-M</b>	⊖	standard	 a richiesta
<b>BXN-BX-BE-BN/ FD*-FA</b>	<b>MXN-MX-ME-M/ FD-FA</b>	standard	 a richiesta	⊖
<b>BX ≥ 200_FD</b> <b>BX ≥ 200K_FD</b>		⊖	standard	⊖
<b>BX ≥ 280K_FD</b>		⊖	standard	 a richiesta

(\*) BX ≤ 180\_FD



<b>IP</b>			<b>5</b>			<b>5</b>		
<b>0</b>		Non protetto	<b>0</b>		Non protetto	<b>0</b>		Non protetto
<b>1</b>		Protetto contro corpi solidi estranei di $\varnothing \geq 50$ mm	<b>1</b>		Protetto contro la caduta verticale di gocce d'acqua	<b>1</b>		Protetto contro la caduta verticale di gocce d'acqua
<b>2</b>		Protetto contro corpi solidi estranei di $\varnothing \geq 12.5$ mm	<b>2</b>		Protetto contro la caduta verticale di gocce d'acqua con un'inclinazione fino a 15°	<b>2</b>		Protetto contro la caduta verticale di gocce d'acqua con un'inclinazione fino a 15°
<b>3</b>		Protetto contro corpi solidi estranei di $\varnothing \geq 2.5$ mm	<b>3</b>		Protetto contro la pioggia	<b>3</b>		Protetto contro la pioggia
<b>4</b>		Protetto contro corpi solidi estranei di $\varnothing \geq 1.0$ mm	<b>4</b>		Protetto contro gli spruzzi d'acqua da tutte le direzioni	<b>4</b>		Protetto contro gli spruzzi d'acqua da tutte le direzioni
<b>5</b>		Protetto contro la polvere	<b>5</b>		Protetto contro i getti d'acqua	<b>5</b>		Protetto contro i getti d'acqua
<b>6</b>		Nessun ingresso di polvere	<b>6</b>		Protetto contro getti d'acqua a pressione	<b>6</b>		Protetto contro getti d'acqua a pressione
			<b>7</b>		Protetto contro gli effetti dell'immersione temporanea	<b>7</b>		Protetto contro gli effetti dell'immersione temporanea
			<b>8</b>		Protetto contro gli effetti dell'immersione continua	<b>8</b>		Protetto contro gli effetti dell'immersione continua

### M6.3 Ventilazione

I motori sono raffreddati mediante ventilazione esterna (IC 411 secondo CEI EN 60034-6) e sono provvisti di ventola radiale in plastica che funziona in entrambi i sensi di rotazione.

L'installazione deve assicurare una distanza minima dalla calotta copriventola alla parete in modo da non avere impedimenti all'ingresso aria e permettere la possibilità di eseguire l'opportuna manutenzione del motore e, se previsto, del freno.

Su richiesta è possibile prevedere una ventilazione forzata indipendente (opzione **U1**). Questa soluzione consente di aumentare il fattore di utilizzo del motore nel caso di alimentazione da inverter e funzionamento a giri ridotti.

### M6.4 Senso di rotazione

È possibile il funzionamento in entrambi i sensi di rotazione.

Con collegamento dei morsetti U1,V1,W1 alle fasi di linea L1,L2,L3 si ha rotazione oraria vista dal lato accoppiamento, mentre la marcia antioraria si ottiene scambiando fra loro due fasi.

### M6.5 Rumorosità

I valori di rumorosità, rilevati secondo il metodo previsto dalle Norme ISO 1680, sono contenuti entro i livelli massimi previsti dalle Norme CEI EN 60034-9.



## M6.6 Vibrazioni ed equilibratura



I motori sono equilibrati dinamicamente con mezza linguetta e rientrano nel grado di vibrazione A, secondo la Norma CEI EN 60034-14.

## M6.7 Morsettiera motore

La morsettiera dei motori legacy (BN/M - BE/ME - BX/MX) è dotata di 6 perni per il collegamento del terminale ad occhiello mentre i motori EVOX BXN e MXN hanno sempre 9 perni di serie.

Quando un motore legacy ha l'opzione UL attiva, la morsettiera presenta un'esecuzione a 9 perni (per tensione US "Doppia Tensione"). All'interno della scatola è previsto un morsetto per il conduttore di terra per il collegamento del conduttore di protezione. Le dimensioni dei perni di attacco sono riportate nella tabella seguente. Per l'alimentazione del freno vedi par. M9 (freno FD), M10 (freno FA). Nel caso di motori autofrenanti, il raddrizzatore per l'alimentazione del freno è fissato all'interno della scatola e provvisto di adeguati morsetti di collegamento. Eseguire i collegamenti secondo gli schemi riportati all'interno della scatola coprimorsetti o nei manuali d'uso.



(F10)

		N° terminali	Filettatura terminali
<b>BXN 63 ... BXN 90</b>	<b>MXN05 ... MXN25</b>	9	M4
<b>BX 80, BX 90</b> <b>BE 63 ... BE 90</b> <b>BN 56 ... BN 90</b>	<b>MX2, MX3</b> <b>ME05 ... ME3</b> <b>M05 ... M2</b>	6	M4
<b>BX 100 ... BX 132</b> <b>BE 100 ... BE 132</b> <b>BN 100 ... BN 160MR</b>	<b>MX3, MX4</b> <b>ME3, ME4</b> <b>M3 ... M4</b>	6	M5
<b>BX 160 - BE 160 ... BE 180M</b> <b>BN 160M ... BN 180M</b>	<b>ME5</b> <b>MX5 - M5</b>	6	M6
<b>BX 180 - BE 180L</b> <b>BN 180L ... BN 200L</b>	—	6	M8
<b>BX 200 ... BX 250</b> <b>BX 200K ... BX 250K</b>	—	6	M10
<b>BX 280 ... BX 355</b> <b>BX 280K ... BX 355K</b>	—	6	M12
<b>BX 80 ... BX 132</b> <b>BE 71 ... BE 132</b> <b>BN 63 ... BN 160MR</b>	<b>MX2 ... MX4</b> <b>ME2 ... ME4</b> <b>M05 ... M4</b>	9	M4
<b>BX 160 ... BX 180</b> <b>BE 160 ... BE 180</b> <b>BN 160M ... BN 200L</b>	<b>MX5</b> <b>ME5</b> <b>M5</b>	9	M6

## M6.8 Ingresso cavi

Nel rispetto della Norma EN 50262, i fori di ingresso cavi nelle scatole morsettiera presentano filettature metriche della misura indicata nella tabella seguente.

(F11)

		Ingresso cavi e dimensioni		Diametro max. cavo allacciabile [mm]
<b>BXN 63</b>	<b>MXN 05</b>	2 x M20 x 1.5	1+1 fori per lato	13
		2 x M16 x 1.5		11
<b>BXN 71 ... BXN 90</b>	<b>MXN 10 ... MXN 25</b>	2 x M25 x 1.5	1+1 fori per lato	17
		2 x M16 x 1.5		11
<b>BN 63 - BE 63</b>	<b>M05 - ME05</b>	2 x M20 x 1.5	1 foro per lato	13
<b>BN71 ... BN90, BE71 ... BE90, BX80 ... BX90</b>	<b>M1 - M2, ME1 - ME2, MX2</b>	2 x M25 x 1.5		17
<b>BN100 - BN112, BE100 - BE112, BX100 - BX112</b>	<b>MX3, MX4 - ME3 M3</b>	2 x M32 x 1.5	2 fori per lato	21
		2 x M25 x 1.5		17
<b>BN132 ... BN160MR, BE132, BX132</b>	<b>M4, ME4, MX4</b>	4 x M32 x 1.5	Orientabili 4 x 90°	21
<b>BN160M ... BN200L, BE160 - BE180, BX160 - BX180</b>	<b>M5, ME5, MX5</b>	2 x M40 x 1.5		28
<b>BX 200 ... BX 355</b> <b>BX 200K ... BX 355K</b>	—	2 x M63 x 1.5	Orientabili 4 x 90°	45





## M6.9 Cuscinetti

I cuscinetti previsti sono del tipo radiale a sfere con lubrificazione permanente precaricati assialmente. I tipi utilizzati sono indicati nelle tabelle seguenti. La durata nominale a fatica  $L_{10h}$  dei cuscinetti, in assenza di carichi esterni applicati è superiore a 40.000 ore, calcolata secondo ISO 281.

**DE** = lato comando

**NDE** = lato opposto comando

(F12)

	DE	NDE	
		Senza Freno	Con Freno
<b>MXN 05 - ME05 - M05</b>	6004 2Z C3	6201 2Z C3	6201 2RS C3
<b>MXN 10 - ME1 - M1</b>	6004 2Z C3	6202 2Z C3	6202 2RS C3
<b>MXN 20 - MX2 - ME2 - M2</b>	6007 2Z C3	6204 2Z C3	6204 2RS C3
<b>MXN 25 - MX3 - ME3 - M3</b>	6207 2Z C3	6206 2Z C3	6206 2RS C3
<b>MX4 - ME4 - M4</b>	6309 2Z C3	6308 2Z C3	6308 2RS C3
<b>MX5 - ME5 - M5</b>	6309 2Z C3	6309 2Z C3	6309 2RS C3

	DE	NDE	
		Senza Freno	Con Freno
<b>BN 56</b>	6201 2Z C3	6201 2Z C3	-
<b>BXN 63 - BE 63 BN 63</b>	6201 2Z C3	6201 2Z C3	6201 2RS C3
<b>BXN 71 - BE 71 BN 71</b>	6202 2Z C3	6202 2Z C3	6202 2RS C3
<b>BXN 80 - BX 80 BE 80 - BN 80</b>	6204 2Z C3	6204 2Z C3	6204 2RS C3
<b>BXN 90 - BX 90 BE 90 - BN 90</b>	6205 2Z C3	6205 2Z C3	6305 2RS C3
<b>BX 100 - BE 100 - BN 100</b>	6206 2Z C3	6206 2Z C3	6206 2RS C3
<b>BX 112 - BE 112 - BN 112</b>	6306 2Z C3	6306 2Z C3	6306 2RS C3
<b>BX 132 - BE 132 - BN 132</b>	6308 2Z C3	6308 2Z C3	6308 2RS C3
<b>BN 160MR</b>	6309 2Z C3	6308 2Z C3	6308 2RS C3
<b>BX 160M/L - BE 160M/L - BN 160M/L</b>	6309 2Z C3	6309 2Z C3	6309 2RS C3
<b>BN 180M</b>	6310 2Z C3	6309 2Z C3	6309 2RS C3
<b>BX 180M/L - BE 180M/L - BN 180L</b>	6310 2Z C3	6310 2Z C3	6310 2RS C3

	DE	NDE	
		Senza Freno	Con Freno
<b>BN 200L - BX 200 - BX 200K</b>	6312 2Z C3 6312/C3	6310 2Z C3 6210/C3*	6310 2RS C3
<b>BX 225 - BX 225K</b>	6313/C3*	6212/C3*	-
<b>BX 250 - BX 250K</b>	6315/C3*	6213/C3*	-
<b>BX 280 - BX 280K</b>	6316/C3*	6316/C3*	-
<b>BX 315 - BX 315K</b>	6319/C3**	6316/C3**	-
<b>BX 355 - BX 355K</b>	6322/C3**	6316/C3**	-

\*Cuscinetti ingrassabili con dispositivo di ingrassaggio M6x1

\*\*Cuscinetti ingrassabili con dispositivo di ingrassaggio M10x1

Note: i motori BX e BXN sono dotati di cuscinetti ad alta efficienza



## M7 CARATTERISTICHE ELETTRICHE

### M7.1 Tensione

I motori ad una velocità sono previsti nell'esecuzione standard per tensione nominale 230 / 400 V  $\Delta/Y$ , 50 Hz, o 400 / 690 V  $\Delta/Y$ , 50 Hz, con tolleranza di tensione  $\pm 10\%$ .

NOTA: La tensione/frequenza di alimentazione dei motori è anche dipendente dall'eventuale selezione di opzioni relative alle certificazioni per mercati specifici. La tabella sottostante deve quindi essere considerata solamente come linea guida, per maggiori dettagli sulle tensioni disponibili in funzione della certificazione selezionata, fare riferimento ai paragrafi M7.5 - M7.10.

Per tutti i motori, la cui configurazione tensione / frequenza non sia come sopra indicato, la tolleranza di tensione è ridotta al  $\pm 5\%$ .

Per il funzionamento ai limiti di tolleranza, la temperatura può superare di 10 K il limite previsto dalla classe di isolamento adottata.

I motori sono idonei per il funzionamento sulla rete di distribuzione europea con tensione in accordo alla pubblicazione IEC 60038.

(F13)

Tensioni Alimentazione Motori BN - M (IE1)				
Motori singola polarità a 50Hz				
Tensione alimentazione motore	— (CE)		CCC	CUS
	STD	FD / FA		
220/380 - 50	X	✓	X	✓
230/400 - 50	✓	✓	✓	✓
240/415 - 50	X	✓	X	✓
290/500 - 50	✓	✓	X	✓
380/660 - 50	X	✓	X	✓
400/690 - 50	✓	✓	X	✓
415/720 - 50	X	✓	X	✓
500/865 - 50	✓	✓	X	✓
Motori doppia polarità a 50Hz				
Tensione alimentazione motore	— (CE)		CCC	CUS
	STD	FD / FA		
380 - 50	✓		X	✓
400 - 50	✓		✓	✓
415 - 50	✓		X	✓
500 - 50	✓		X	✓
Motori singola polarità a 60Hz				
Tensione alimentazione motore	— (CE)		CCC	CUS
	STD	FD / FA		
208/360 - 60	✓	✓	X	✓
220/380 - 60	✓	✓	X	✓
230/400 - 60	✓	✓	X	✓
255/440 - 60	X	✓	X	✓
265/460 - 60	X	✓	✓	✓
280/480 - 60	X	✓	X	✓
330/575 - 60	✓	✓	X	✓
380/660 - 60	✓	✓	X	✓
400/690 - 60	✓	✓	X	✓
440/760 - 60	X	✓	X	✓
460/800 - 60	X	✓	X	✓
480/830 - 60	X	✓	X	✓
575/995 - 60	✓	✓	X	✓
220/440 - 60	✓	✓	X	✓
230/460 - 60	✓	✓	X	✓
240/480 - 60	✓	✓	X	✓
Motori doppia polarità a 60Hz				
Tensione alimentazione motore	— (CE)		CCC	CUS
	STD	FD / FA		
208 - 60	✓		X	✓
220 - 60	✓		X	✓
230 - 60	✓		X	✓
240 - 60	✓		X	✓
380 - 60	✓		X	✓
400 - 60	✓		X	✓
440 - 60	✓		X	✓
460 - 60	✓		X	✓
480 - 60	✓		X	✓
575 - 60	✓		X	✓



(F14)

Tensioni Alimentazione Motori BE - ME (IE2)					
Motori singola polarità a 50Hz					
Tensione alimentazione motore	— (CE)	CCC	BIS	CUS	
220/380 - 50	✓	✗	✓	✓	
230/400 - 50	✓	✓	✓	✓	
240/415 - 50	✓	✗	✓	✓	
290/500 - 50	✓	✗	✓	✓	
380/660 - 50	✓	✗	✓	✓	
400/690 - 50	✓	✗	✓	✓	
415/720 - 50	✓	✗	✓	✓	
500/865 - 50	✓	✗	✓	✓	

Motori singola polarità a 60Hz					
Tensione alimentazione motore	— (CE)		CCC	BIS	CUS
	STD	FD / FA			
208/360 - 60	✓	✓	✗	✗	✓
220/380 - 60	✓	✓	✗	✗	✓
230/400 - 60	✓	✓	✗	✗	✓
255/440 - 60	✓	✓	✗	✗	✓
265/460 - 60	✗	✓	✗	✗	✓
280/480 - 60	✓	✓	✗	✗	✓
330/575 - 60	✗	✓	✗	✗	✓
380/660 - 60	✓	✓	✗	✗	✓
400/690 - 60	✓	✓	✗	✗	✓
440/760 - 60	✓	✓	✗	✗	✓
460/800 - 60	✗	✓	✗	✗	✓
480/830 - 60	✓	✓	✗	✗	✓
575/995 - 60	✓	✓	✗	✗	✓
220/440 - 60	✓	✓	✗	✗	✓
230/460 - 60	✓	✓	✗	✗	✓
240/480 - 60	✓	✓	✗	✗	✓

Tensioni Alimentazione Motori BX - MX (IE3)						
Motori singola polarità a 50Hz						
Tensione alimentazione motore	— (CE)	CCC	CEL	NBR	BIS	CUS
230/400-50	✓ <sup>(1)</sup>	✗	✓ <sup>(6)</sup>	✗	✗	✗
290/500-50	✓	✗	✗	✗	✗	✗
380/660-50	✗	✗	✓ <sup>(4)</sup>	✗	✗	✗
400/690-50	✓ <sup>(2)</sup>	✗	✓ <sup>(2) (3)</sup>	✗	✗	✗



Motori singola polarità a 60Hz							
Tensione alimentazione motore	— (CE)		CCC	CEL	NBR <sup>(*)</sup>	BIS	CUS
	STD	FD / FA					
220/380-60	✗	✗	✗	✗	✓ <sup>(3)</sup>	✗	✓
265/460-60	✗	✓ <sup>(1)</sup>	✗	✗	✗	✗	✓
330/575-60	✗	✓ <sup>(3)</sup>	✗	✗	✗	✗	✓
380/660-60	✗	✗	✗	✗	✓ <sup>(5)</sup>	✗	✓
440/760-60	✗	✗	✗	✗	✓ <sup>(4)</sup>	✗	✓
460/800-60	✗	✓ <sup>(2) (3)</sup>	✗	✗	✗	✗	✓
220/440-60	✗	✗	✗	✗	✓ <sup>(3)</sup>	✗	✓
230/460-60	✗	✗	✗	✗	✗	✗	✓

(1) solo per motori taglia ≤132      (3) solo per motori taglia ≤180      (5) solo per motori taglia 180  
(2) solo per motori taglia ≥160      (4) solo per motori taglia ≥200      (6) solo per motori taglia ≥100



Nella tabella seguente sono indicati i vari tipi di collegamenti previsti per i motori in funzione della polarità.

(F15)

Poli			Collegamento avvolgimento
2	BE 80 ... BE 160, BN 63 ... BN 200	ME2 ... ME5, M05 ... M5	$\Delta / Y^{(2)}$
4	BXN 63 ... BXN 90, BX 80 ... BX 355 BX 200LAK ... BX 355MCK BE 63 ... BE 180, BN 56 ... BN 200	MXN05 ... MXN25, MX2 ... MX5 — ME05 ... ME5, M05 ... M5	
6	BE 90 ... BE 160, BN 63 ... BN 200	ME3 ... ME5, M05 ... M5	
8	BN 71 ... BN 132	M1 ... M4	
2/4	BN 63 ... BN 132	M05 ... M4	$\Delta / YY$ (Dahlander)
2/6	BN 71 ... BN 132	M1 ... M4	$Y / Y$ (due avvolgimenti)
2/8	BN 71 ... BN 132	M1 ... M4	
2/12	BN 80 ... BN 132	M2 ... M4	
4/6	BN 71 ... BN 132	M1 ... M4	
4/8	BN 80 ... BN 132	M2 ... M4	$\Delta / YY$ (Dahlander)





(<sup>2</sup>) I motori con tensione in rapporto 2 (es. 230/460-60) saranno dotati di morsetti a 9 perni con collegamento  $\Delta/\Delta$  o  $YY/Y$  (eccetto il BN 63 6 poli  $\Delta/Y$ )

**NOTA:** Per i motori BXN e MXN fare riferimento al catalogo EVOX

## M7.2 Frequenza

La potenza di targa dei motori BN / M a 60 Hz corrisponde a quanto riportato nella tabella seguente.

(F16)

		$P_n$ [kW]						$P_n$ [kW]			
		2P	4P	6P	8P (*)			2P	4P	6P	8P (*)
BN 56A	—	—	0.07	—	—	BN 100L	M3LA	3.5	—	—	—
BN 56B	M0B	—	0.1	—	—	BN 100LA	M3LA	—	2.5	1.8	0.9
BN 63A	M05A	0.21	0.14	0.1	—	BN 100LB	M3LB	4.7	3.5	2.2	1.3
BN 63B	M05B	0.3	0.21	0.14	—	BN 112M	—	4.7	4.7	2.5	1.8
BN 63C	M05C	0.45	0.3	—	—	—	M3LC	—	4.7	2.5	—
BN 71A	—	0.45	0.3	0.21	0.1	BN 132S	M4SA	—	6.5	3.5	2.5
—	M1SC	—	—	0.21	—	BN 132SA	M4SA	6.5	—	—	—
BN 71B	M05SD	0.65	0.45	0.3	0.14	BN 132SB	M4SB	8.7	—	—	—
BN 71C	M1LA	0.9	0.65	0.45	—	BN 132M	M4LA	11	—	—	3.5
BN 80A	—	0.9	0.65	0.45	0.21	BN 132MA	M4LA	—	8.7	4.7	—
BN 80B	M2SA	1.3	0.9	0.65	0.30	BN 132MB	M4LB	—	11	6.5	—
BN 80C	M2SB	1.8	1.3	0.9	—	BN 160MR	M4LC	12.5	12.5	—	—
BN 90S	—	—	1.3	0.9	0.45	BN 160M	M5SA	—	—	8.7	—
BN 90SA	—	1.8	—	—	—	BN 160MB	—	17.5	—	—	—
BN 90SB	—	2.2	—	—	—	—	M5SB	17.5	17.5	—	—
BN 90L	M3SA	2.5	—	1.3	0.65	BN 160L	—	21.5	17.5	12.5	—
BN 90LA		—	1.8	—	—	—	M5SC	21.5	—	—	—
BN 90LB	—	—	2.2	—	—	BN 180M	M5LA	24.5	21.5	—	—
						BN 180L	—	—	25.3	17.5	—
						BN 200L	—	—	34	—	—
						BN 200LA	—	34	—	22	—

(\*) Escluso motori M\_



I motori BXN / BX / BE / MXN / MX / ME a 60 Hz sono disponibili nella sola versione a 4 poli e hanno la stessa potenza dei corrispondenti a 50 Hz. Motori BN / M a doppia polarità alimentati a 60 Hz avranno un aumento della potenza nominale, riferita a 50 Hz, pari al 15%, mentre non sono previsti motori BXN / BX / BE / MXN / MX / ME a doppia polarità.

Qualora sulla targhetta di un motore destinato ad essere alimentato a 60 Hz sia richiesto un valore di potenza nominale pari a quello normalizzato a 50 Hz, specificare in designazione l'opzione PN.

I motori normalmente avvolti per frequenza 50 Hz possono essere usati in reti a 60 Hz, ma i relativi dati dovranno essere corretti secondo la seguente tabella. Ad esclusione di esecuzioni CUS e autofrenanti, i motori configurati a 50 Hz riportano in targhetta anche i corrispondenti valori a 60 Hz (vedere tabella sottostante).

(F17)

	50 Hz	60 Hz			
	V - 50 Hz	V - 60 Hz	P <sub>n</sub> - 60 Hz	M <sub>n</sub> , M <sub>a</sub> /M <sub>n</sub> - 60 Hz	n [min <sup>-1</sup> ] - 60 Hz
BXN / MXN BX / MX BE / ME	230/400 Δ/Y	265 - 460 Δ Y	1	0.83	1.2
	400/690 Δ/Y	460 Δ			
BN / M	230/400 Δ/Y	220 - 240 Δ			
		380 - 415 Y			
	400/690 Δ/Y	380 - 415 Δ			
BN / M	230/400 Δ/Y	265 - 280 Δ			
		440 - 480 Y			
	400/690 Δ/Y	440 - 480 Δ			

NOTA: Per i motori BXN e MXN fare riferimento al catalogo EVOX

### M7.3 Temperatura ambiente

Le tabelle dei dati tecnici del catalogo riportano le caratteristiche funzionali a 50 Hz in condizioni ambientali standard secondo le Norme CEI EN 60034-1 (temperatura compresa tra -15 °C e +40 °C ed altitudine ≤ 1000 m s.l.m.).

I motori possono essere impiegati a temperature comprese tra 40 °C e 60 °C applicando i declassamenti di potenza indicati nella tabella seguente.

(F18)

Temperatura ambiente (°C)	40°	45°	50°	55°	60°
Potenza ammissibile in % della potenza nominale	100%	95%	90%	85%	80%

Quando è richiesto un declassamento del motore superiore al 15%, contattare il ns. Servizio Tecnico.

### M7.4 Potenza normalizzata a 50 Hz

**PN**

L'opzione consente di avere sulla targa del motore il valore di potenza normalizzata a 50 Hz, anche quando è specificata l'alimentazione a 60 Hz. Per alimentazioni a 60 Hz con le tensioni 230/460V e 575V l'opzione PN viene applicata di default.



## M7.5 Motori per USA e Canada

### CUS

L'opzione CUS è disponibile per motori BN, BE, M, ME in esecuzione NEMA Design C, e per i motori BX, MX in esecuzione NEMA Design B, per le caratteristiche elettriche. I motori BXN e MXN sono certificati CUS di serie. I motori sono certificati in conformità alle norme CSA (Canadian Standard) C22.2 N° 100 e UL (Underwriters Laboratory) UL 1004-1, come indicatori sul file UL E308649. Tutte le potenze BN-BE-M-ME e BXN-MXN con potenze comprese tra 0,12 e 0,55kW incluse le targhette dei motori riportano i seguenti contrassegni:



I motori BXN/MXN  $\geq 0,75\text{kW}$  e BX/MX  $\geq 0,75\text{kW}$  riportano in targhetta i due loghi sotto rappresentati e sono certificati in conformità alle normative di efficienza energetica vigenti in USA e Canada, rispettivamente previste dal DOE (10 CFR Part 431) e dall'NRCAN (Energy Efficiency Regulations), testati in conformità a quanto prescritto dalla norma CSA C390.



La grandezza BX 100 è disponibile per il solo mercato USA e non per il Canada, e per questa taglia i loghi riportati in targhetta sono i seguenti:



I motori BX $\geq$ 200K riportano in targhetta il logo sotto rappresentato e sono certificati in conformità alle normative di efficienza energetica vigenti in USA e Canada, rispettivamente previste dal DOE (10 CFR Part 431) e dall'NRCAN (Energy Efficiency Regulations), testati in conformità a quanto prescritto dalla norma CSA C390.



#### NOTE:

A partire dal **01/06/2016** motori CUS con livello di efficienza inferiore all'IE3 (i.e. "Premium Efficiency") non possono essere commercializzati negli USA e in Canada a meno che una o più tra le seguenti condizioni siano verificate:

- Motori a doppia polarità;
- Motori targati per servizio discontinuo (<80%);
- Motori destinati al solo funzionamento tramite inverter (opportunamente equipaggiati con etichetta "Inverter Duty Only" o similare).

L'opzione CUS è applicabile ai motori dotati di servoventilazione solo se BX $\geq$ 200K.

Le tensioni delle reti di distribuzione americane e le corrispondenti tensioni nominali da specificare per il motore sono indicate nella tabella seguente:

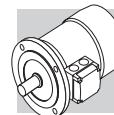

(F19)

Frequenza	Tensione di rete	$V_{mot}$
60 Hz	208 V	<b>200 V</b>
	240 V	<b>230 V</b>
	480 V	<b>460 V</b>
	600 V	<b>575 V</b>

I motori BX con opzione CUS sono disponibili con i seguenti valori di tensione/frequenza:

(F20)

	$V_{mot}$
BX $\leq$ 132	265/460 - 60 Hz
BX $\leq$ 180	230/460 - 60 Hz 330/575 - 60 Hz
BX $\geq$ 160 BX $\geq$ 200K	460/800 - 60 Hz

L'opzione CUS è applicabile anche ai motori a 50 Hz (motori BX, MX esclusi).

#### M7.6 Motori Certificati per il mercato Indiano

**BIS**

Tutti i motori in bassa tensione  $\geq 0.12$  kW prodotti o importati in India devono essere certificati dal Bureau of Indian Standard e forniti con un marchio attestante la conformità del motore agli standard definiti nello IS 12615. I motori BE - ME 4 poli con potenze fino a 3.7 kW compresa, sono disponibili con la suddetta certificazione e quando selezionata l'opzione BIS vengono forniti con la targhetta riportante il seguente logo:



#### M7.7 China Compulsory Certification

**CCC**

I motori elettrici destinati ad essere commercializzati nella Repubblica Popolare Cinese rientrano nell'applicabilità del sistema di certificazione CCC (China Compulsory Certification). I motori BN/M e BE/ME con coppia nominale fino a 7 Nm sono disponibili con certificazione CCC e targhetta speciale riportante il marchio sotto illustrato:



L'opzione CCC non è al momento disponibile per i motori IE3, lo sarà a partire dalla fine del 2021.  
L'opzione CCC non è applicabile ai motori dotati di servoventilazione.



## M7.8 Motori Certificati per il mercato Cinese (China Energy Label)

### CEL

Tutti i motori in bassa tensione  $\geq 0.75$  kW prodotti o importati in Cina devono essere certificati e registrati dall'ufficio Marchi e forniti con un'etichetta energetica attestante la conformità del motore ai livelli di efficienza minimi (Gradi) definiti nella GB18613-2012.

I motori BX con potenze da 30 a 355 kW sono disponibili con la certificazione CEL. I suddetti motori sono forniti con la etichetta mostrata sotto direttamente applicata al motore.

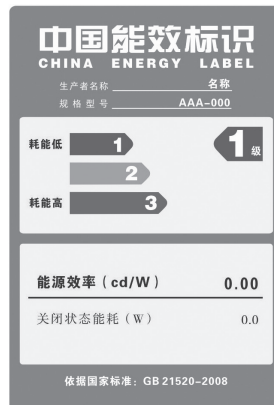

I motori BX con opzione CEL sono disponibili con i seguenti valori di tensione/frequenza:

(F21)		$V_{mot}$
	BX $\geq$ 200	380/660 - 50 Hz

## M7.9 Motori certificati per il mercato Brasiliano

### NBR

La legislazione Brasiliana regola la produzione e importazione di motori elettrici all'interno del paese. I motori, infatti, devono essere approvati dall'NBR attraverso la dichiarazione dei livelli di efficienza da essi raggiunti all'INMETRO. I motori conformi all'NBR devono riportare il valore di efficienza dichiarato e forniti con una targhetta NBR dedicata ed il marchio addizionale mostrato nella figura sottostante.



L'opzione NBR è disponibile per i motori:

- BX con potenze da 0,75 a 22 kW compresi
- BX...K con potenze da 30 a 355 kW compresi





I motori BX con opzione NBR sono disponibili con i seguenti valori di tensione/frequenza:

(F22)

	$V_{mot}$
BX90SR ... BX160	220/380 - 60 Hz 220/440 - 60 Hz
BX 180	220/380 - 60 Hz 220/440 - 60 Hz 380/660 - 60 Hz
BX $\geq$ 200K	440/760 - 60 HZ

#### M7.10 Motori certificati per il mercato Australiano

### EECA

I motori elettrici appartenenti alle categorie coperte dalla normativa per poter essere venduti in Australia e Nuova Zelanda devono essere registrati all'interno del database nazionale Energyrating. I motori con opzione EECA sono registrati nel database sopra menzionato e possono quindi essere commercializzati in Australia e Nuova Zelanda.

L'opzione EECA è disponibile per motori BX...K con potenze da 30 a 355kW.

I motori BX...K con opzione EECA sono disponibili con i seguenti valori di tensione/frequenza:

(F23)

	$V_{mot}$
BX $\geq$ 200K	400/690 - 50 Hz

#### M7.11 Classe d'isolamento

### CL F

I motori di produzione Bonfiglioli impiegano, di serie, materiali isolanti (filo smaltato, isolanti, resine d'impregnazione) in classe **F**. In genere, per i motori in esecuzione standard la sovratemperatura dell'avvolgimento statore è contenuta entro il limite di 80 K, corrispondente alla sovratemperatura di classe B. L'accurata scelta dei componenti del sistema isolante consente l'impiego dei motori anche in climi tropicali ed in presenza di vibrazioni normali. Per applicazioni in presenza di sostanze chimiche aggressive, o di elevata umidità, è consigliabile contattare il Servizio Tecnico Bonfiglioli per la selezione del prodotto più idoneo.



## CL H

Su richiesta può venire specificata la classe di isolamento **H**

Questa opzione può essere selezionata per motori conformi agli standard CSA e UL (opzione CUS) solo per taglie  $BX \geq 200$  e  $BX \geq 200K$ .

CLH non può essere selezionato sui motori BXN perché sono standard CUS. Se necessario contattare l'ufficio tecnico.

(F25)

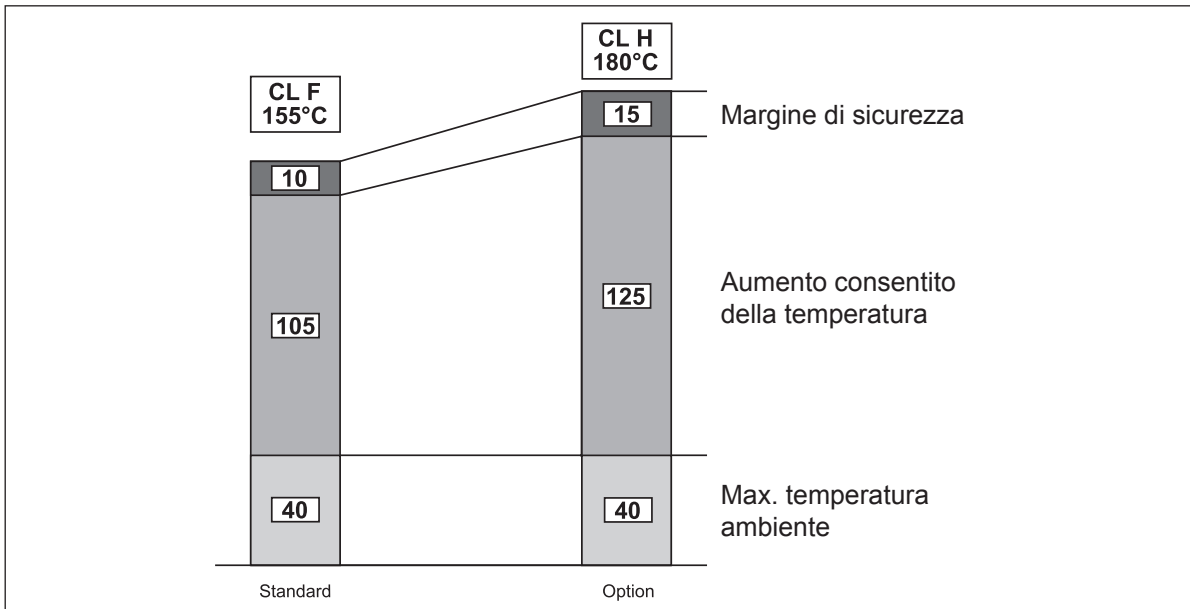

### M7.12 Tipo di servizio

Se non indicato diversamente, la potenza dei motori riportata a catalogo si riferisce al servizio continuo S1. Per i motori utilizzati in condizioni diverse da S1 sarà necessario identificare il tipo di servizio previsto con riferimento alle Norme CEI EN 60034-1. In particolare per servizi S2 ed S3 è possibile ottenere una maggiorazione della potenza rispetto a quella prevista per il servizio continuo secondo quanto indicato nella tabella che segue, valida per i motori a singola polarità. In alternativa al servizio continuo S1, in fase di configurazione del prodotto è possibile selezionare uno dei seguenti valori: S2, S3 o S9; la targhetta del motore verrà compilata con potenza aumentata coerentemente al tipo di servizio, dati elettrici dedicati e tipo di servizio rispettivamente S2-30min, S3-70% o S9. Per ulteriori dettagli è necessario contattare il servizio Tecnico Bonfiglioli. Per le maggiorazioni applicabili a motori a doppia polarità consultare preferibilmente il Servizio Tecnico Bonfiglioli.

I motori BN e M possono essere configurati per il funzionamento con ciclo di lavoro S2(30min) e S3(70%) come opzione standard, Altre richieste diverse in termini di % o min sono considerate come speciali.

I motori BXN e MXN possono essere configurati di serie a S2=10min, S2=30min, S2=60min o S3=25%, S3=40%, S3=70%.

(F24)

	Tipo di servizio						
	S2			S3 *			S4 - S9
	Durata del ciclo (min)			Rapporto di intermittenza ( I )			
	10	30 (*)	60	25%	40%	70% (*)	Interpellarci
$f_m$	1.35	1.15	1.05	1.25	1.15	1.1	

\* La durata del ciclo dovrà comunque essere uguale o inferiore a 10 minuti; se superiore interpellare il nostro Servizio Tecnico.

(\*) Valori predefiniti dalle opzioni (tab. F05).



### M7.12.1 Rapporto di intermittenza:

$$I = \frac{t_f}{t_f + t_r} \cdot 100 \quad (01)$$

$t_f$  = tempo di funzionamento a carico costante

$t_r$  = tempo di riposo

### M7.12.2 Servizio di durata limitata S2

Caratterizzato da un funzionamento a carico costante per un periodo di tempo limitato, inferiore a quello richiesto per raggiungere l'equilibrio termico, seguito da un periodo di riposo di durata sufficiente a ristabilire, nel motore, la temperatura ambiente.

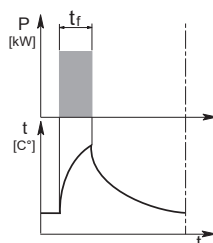

### M7.12.3 Servizio intermittente periodico S3:

Caratterizzato da una sequenza di cicli di funzionamento identici, ciascuno comprendente un periodo di funzionamento a carico costante ed un periodo di riposo. In questo servizio, la corrente di avviamento non influenza la sovratemperatura in modo significativo.

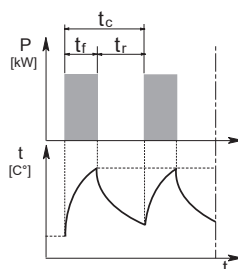

### M7.13 Funzionamento con alimentazione da inverter

I motori elettrici Bonfiglioli possono essere utilizzati con alimentazione da inverter PWM, e tensione nominale all'ingresso del convertitore fino a 500 V. Il sistema isolante sui motori di serie prevede l'isolamento di fase con separatori, l'utilizzo di filo smaltato in grado 2 e resine d'impregnazione in classe H (limite di tenuta all'impulso di tensione 1600V picco-picco e fronte di salita  $t_s > 0.1\mu s$  ai morsetti motore). Le caratteristiche tipiche coppia/velocità in servizio S1 per motore con frequenza base  $f_b = 50$  Hz sono riportate nella tabella seguente. Per frequenze di funzionamento inferiori a circa 30 Hz, a causa della diminuzione della ventilazione, i motori standard autoventilati (IC411) devono essere opportunamente declassati in coppia o, in alternativa, devono essere provvisti di servoventilatore indipendente. Per frequenze maggiori alla frequenza base, raggiunto il valore massimo di tensione di uscita dell'inverter, il motore lavora in un campo di funzionamento a potenza costante, con coppia all'albero che si riduce ca. con il rapporto  $(f/f_b)$ . Poiché la coppia massima del motore decresce ca. con  $(f/f_b)^2$ , il margine di sovraccarico ammesso dovrà essere progressivamente ridotto.

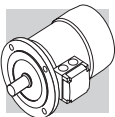

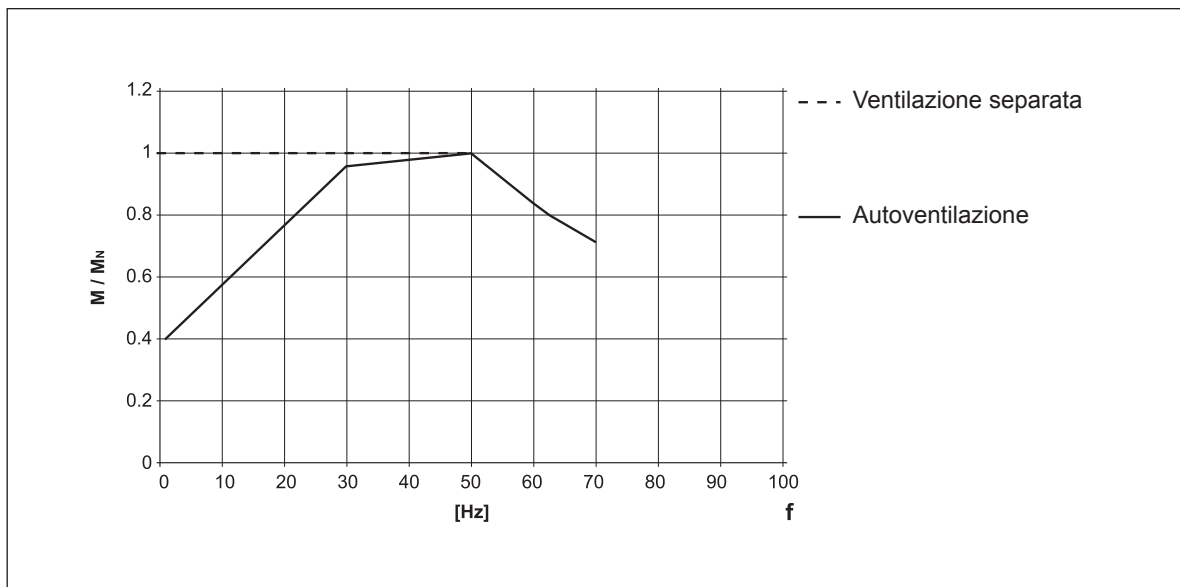

(F26)



Per funzionamento oltre la frequenza nominale, la velocità limite meccanica dei motori è riportata nella seguente tabella:

(F27)

			n [min <sup>-1</sup> ]		
			2p	4p	6p
≤ BE 112 - BN 112		ME2, ME3 M05 ... M3	5200	4000	3000
≥ BE 132 - BN 132		ME4, ME5 M4, M5	4500	4000	3000
BXN 63 ... BXN 90		MXN 05 ... MXN 25		4000	
BX 80 ... BX 180		MX2 ... MX5		4000	

A velocità superiori alla nominale i motori presentano maggiori vibrazioni meccaniche e rumorosità di ventilazione; è consigliabile, per queste applicazioni, un bilanciamento del rotore in grado B e l'eventuale montaggio del servoventilatore indipendente. Il servoventilatore e, se presente, il freno elettromagnetico devono sempre essere alimentati direttamente da rete.

#### M7.14 Frequenza massima di avviamento Z

Nelle tabelle dei dati tecnici motori è indicata la max frequenza di inserzione a vuoto  $Z_0$  con  $I = 50\%$  riferita alla versione autofrenante. Questo valore definisce il numero max di avviamenti orari a vuoto che il motore può sopportare senza superare la max temperatura ammessa dalla classe di isolamento F.

Nel caso pratico di motore accoppiato ad un carico esterno con potenza assorbita  $P_r$ , massa inerziale  $J_c$  e coppia resistente media durante l'avviamento  $M_L$ , il numero di avviamenti ammissibile si può calcolare in modo approssimato con la seguente formula:

$$Z = \frac{Z_0 \cdot K_c \cdot K_d}{K_J} \quad (02)$$

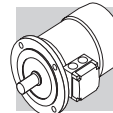

dove:

---

$$K_J = \frac{J_m + J_c}{J_m} \quad \text{fattore di inerzia}$$

---

$$K_c = \frac{M_a - M_L}{M_a} \quad \text{fattore di coppia}$$

---

$$K_d = \quad \text{fattore di carico vedi tabella seguente}$$

---

(F28)

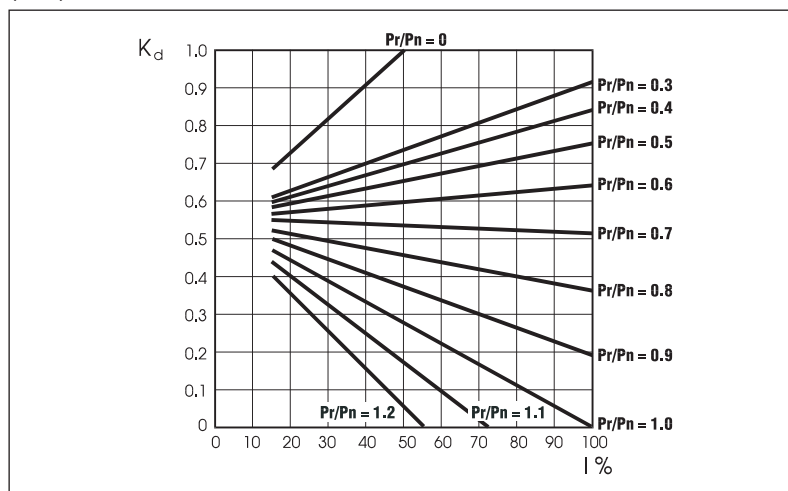

Con il numero di avviamenti così ottenuto si dovrà in seguito verificare che il massimo lavoro di frenatura sia compatibile con la capacità termica del freno  $W_{max}$  indicata nelle tabelle (F38) e (F41).

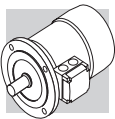

## M8 MOTORI ASINCRONI AUTOFRENANTI

### M8.1 Funzionamento

L'esecuzione autofrenante prevede l'impiego di freni a pressione di molle alimentati in c.c. (tipo FD) o in c.a. (tipo FA).

Tutti i freni funzionano secondo il principio di sicurezza, ossia intervengono in seguito alla pressione esercitata dalle molle, in mancanza di alimentazione.

(F29)

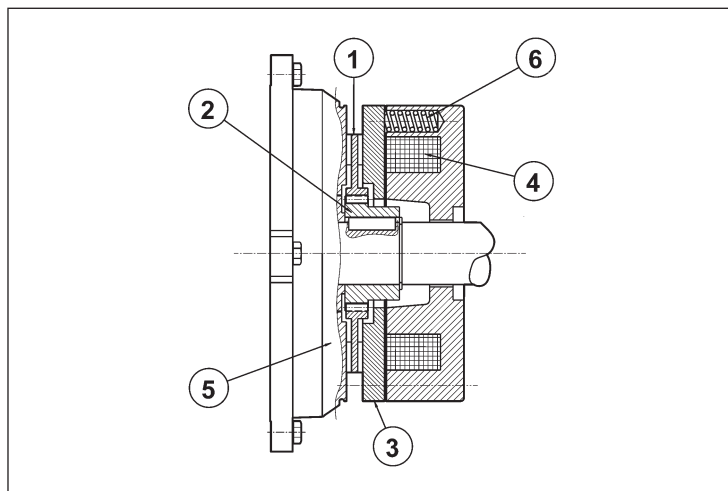

Legenda:

- ① disco
- ② mozzo
- ③ àncora mobile
- ④ bobina
- ⑤ scudo posteriore motore
- ⑥ molle

In mancanza di tensione, l'àncora mobile spinta dalle molle di pressione blocca il disco freno tra la superficie dell'àncora stessa e lo scudo motore impedendo la rotazione dell'albero.

Quando la bobina viene eccitata, l'attrazione magnetica esercitata sull'àncora mobile vince la reazione elastica delle molle e libera il disco freno, e conseguentemente l'albero motore con esso solidale.

### M8.2 Caratteristiche generali

- Coppie frenanti elevate (generalmente  $M_b \approx 2 M_n$ ) e regolabili.
- Disco freno con anima in acciaio a doppia guarnizione d'attrito (materiale a bassa usura, senza amianto).
- Cava esagonale sull'albero motore, lato ventola (NDE), per rotazione manuale (non prevista quando sono presenti le opzioni PS, RC, TC, U1, U2, EN1, EN2, EN3, EN4, EN5, EN6).
- Sblocco meccanico manuale (opzioni **R** e **RM** per FD; opzione **R** per FA).
- Trattamento anticorrosivo di tutte la superfici del freno.
- Isolamento in classe F.



## M9 MOTORI AUTOFRENANTI IN C.C., TIPO BXN-BX-BE-BN\_FD e MXN-MX-ME-M\_FD

**Grandezze:** BXN 63 ... BXN 90, BX 80 ... BX 355M, BX200LAK ... BX 355MCK - BE 63 ... BE 180L - BN 63 ... BN 200L / MXN 05 ... MXN 25 - MX2SB ... MX5LA - ME05 ... ME5 - M05 ... M5

(F30)

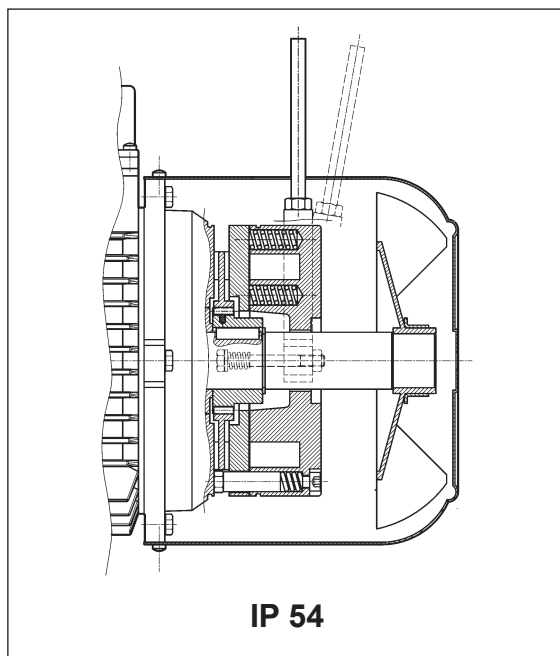

**IP 54**

(F31)

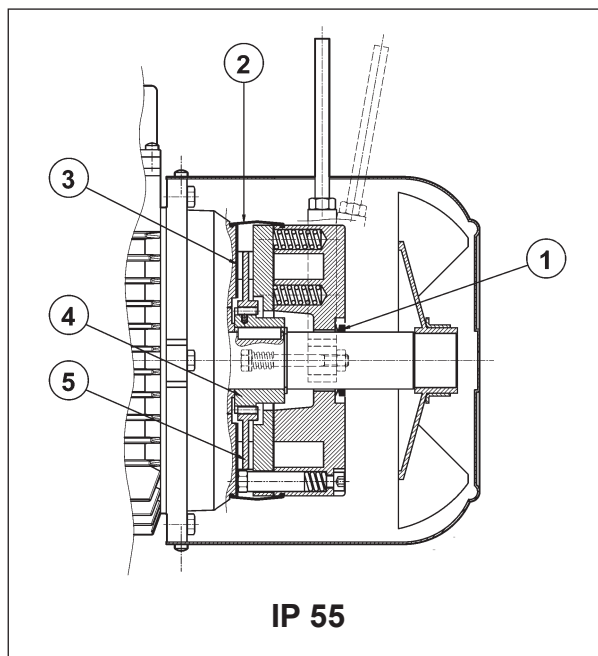

**IP 55**

Freno elettromagnetico con bobina toroidale in **corrente continua** fissato con viti allo scudo motore; le molle di precarico realizzano il posizionamento assiale del corpo magnete.

Il disco freno è scorrevole sul mozzo trascinatore in acciaio calettato sull'albero e previsto di dispositivo antivibrazione.

I motori sono forniti con freno tarato in fabbrica al valore di coppia riportato nelle tabelle dati tecnici; la coppia frenante può essere regolata modificando il tipo e/o il numero delle molle.

A richiesta, i motori possono essere previsti di leva per lo sblocco manuale con ritorno automatico (**R**) o con mantenimento della posizione di rilascio freno (**RM**); per la posizione angolare della leva di sblocco vedi descrizione della relativa variante al paragrafo "SISTEMI DI SBLOCCO FRENO".

Il freno FD garantisce elevate prestazioni dinamiche e bassa rumorosità; le caratteristiche d'intervento del freno in corrente continua possono essere ottimizzate in funzione dell'applicazione, utilizzando i vari tipi di alimentatore disponibili e/o realizzando l'opportuno cablaggio.

**Per applicazioni che prevedono sollevamenti e/o elevati valori di lavoro orario smaltibile, contattare il servizio tecnico commerciale.**

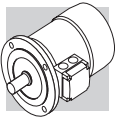

## M9.1 Grado di protezione

L'esecuzione standard prevede il grado di protezione IP54 per tutti i BN - M, BE - ME, BX $\leq$ 180 - MX $\leq$ 5 e BXN - MXN, mentre per BX $\geq$ 200 e BX $\geq$ 200K la protezione standard è IP55.

Per i motori BN - M, BE - ME, BX $\leq$ 180 - MX $\leq$ 5 e BXN - MXN autofrenanti in cui il grado di protezione standard è IP54, si può selezionare come opzione il grado di protezione **IP55**, prevedendo le seguenti varianti costruttive:

- ① anello V-ring posizionato sull'albero motore N.D.E.
- ② protezione in gomma impermeabile e antipolvere
- ③ anello in acciaio inox interposto tra scudo motore e disco freno
- ④ mozzo trascinatore in acciaio inox
- ⑤ disco freno in acciaio inox

## M9.2 Alimentazione freno FD

L'alimentazione della bobina freno in c.c. è prevista per mezzo di opportuno raddrizzatore montato all'interno della scatola coprिमorsetti e già cablato alla bobina del freno.

Indipendentemente dalla frequenza di rete, la tensione di alimentazione del freno  $V_B$  ha il valore indicato nella tabella qui di seguito:

(F32)

Tensione Alimentazione Freni V	Tensioni Alimentazione freno FD		
	Alimentazione dal Motore con Raddrizzatore	Alimentazione separata con Raddrizzatore	Alimentazione senza Raddrizzatore
24	X	X	✓
100	X	X	✓
110	X	✓	X
115	X	✓	X
120	X	✓	X
127	X	✓	X
180	X	X	✓
208	✓	✓	X
220	✓	✓	X
230	✓	✓	✓
240	✓	✓	X
255	✓	X	X
265	✓	X	X
280	✓	X	X
290	✓	X	X
330	✓	X	X
380	✓	✓	X
400	✓	✓	X
415	✓	✓	X
440	✓	✓	X
460	✓	✓	X
480	✓	✓	X
500	✓	✓	X

**NOTA:** Per i motori BXN e MXN fare riferimento al catalogo EVOX





Per i motori a doppia polarità l'alimentazione del freno è obbligatoriamente da linea separata:



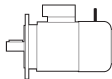

Il raddrizzatore è del tipo a diodi a semionda ( $V_{c.c} \approx 0,45 \times V_{c.a.}$ ) ed è disponibile nelle versioni **NB**, **SB**, **NBR** e **SBR**, come dettagliato nella tabella seguente:

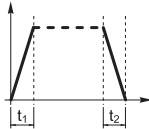
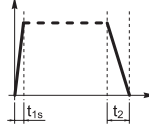
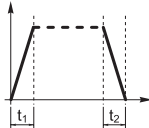
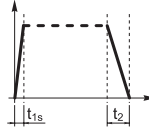
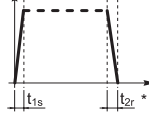
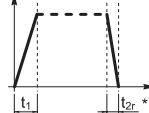
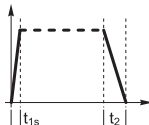
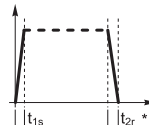
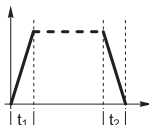
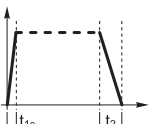
(F33)

			freno			
				standard	a richiesta	
BXN 63		MXN05	FD 02	<b>NB</b> 	<b>SB</b> 	
BXN 71		MXN10	FD 53			
BXN 80		MXN20	FD 04			
BXN 90		—	FD 05			
BE 63 - BN 63		ME05 - M05	FD 02	<b>NB</b> 	<b>SB</b> 	
BE 71 - BN 71		ME1 - M1	FD 03 FD 53			
BX 80 - BE 80 - BN 80		MX2 - ME2 - M2	FD 04		<b>SBR</b> 	
BX 90S - BE 90S - BN 90S		—	FD 14			
BX 90L - BE 90L - BN 90L		—	FD 05			
BX 100 - BE 100 - BN 100		MX3 - ME3 - M3	FD 15		<b>NBR</b> 	
—			FD 55			
BX 112 - BE 112 - BN 112		—	FD 06S		<b>SB</b> 	<b>SBR</b> 
BX 132 - BE 132 - BN 132 - BN 160MR		MX4 - ME4 - M4	FD 56 FD 06 FD 07			
BX 160 - BE 160L - BN 160L - BN 180M		MX5 - ME5 - M5	FD 08			
BX 180 - BE 180L - BN 180L - BN 200M		—	FD 09			
BX 200LA		—	FD 20			
BX 225SA		—	FD 25	<b>NB</b> 	<b>SB</b> 	
BX 250M - BX 315SA		—	FD 30			
BX 315SB - BX 315SC		—	FD 160			
BX 315MA - BX 355MA		—	FD 250			
BX 355MB - BX 355MC		—	FD 400			
BX 200LAK		—	FD 8			
BX 225SAK - BX 225SBK		—	FD 9			
BX 250MAK		—	FD 10			
BX 280SAK - BX 315SAK		—	FD 1000			
BX 315SBK - BX 315SCK		—	FD 1600			
BX 355SAK - BX 355MCK		—	FD 2500			
						

(\*)  $t_{2c} < t_{2r} < t_2$

Per i motori BXN vedere la “Sezione freni” sul catalogo EVOX.

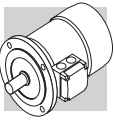

Il raddrizzatore **SB** a controllo elettronico dell'eccitazione, riduce i tempi di sblocco del freno sovrecitando l'elettromagnete nei primi istanti d'inserzione, per passare poi al normale funzionamento a semionda a distacco del freno avvenuto.

L'impiego del raddrizzatore tipo **SB** è sempre da prevedere nei casi di:

- elevato numero di interventi orari
- tempi di sblocco freno ridotti
- elevate sollecitazioni termiche del freno

Per applicazioni dove è richiesto un rapido intervento (ripristino della condizione frenante) del freno sono disponibili a richiesta i raddrizzatori **NBR** o **SBR**.

Questi raddrizzatori completano i tipi **NB** e **SB**, integrando nel circuito elettronico un interruttore statico che interviene diseccitando rapidamente il freno in caso di mancanza di tensione.

Questa soluzione consente di ridurre i tempi di rilascio del freno evitando ulteriori cablaggi e contatti esterni.

Per il migliore utilizzo dei raddrizzatori **NBR** e **SBR** è richiesta l'alimentazione separata del freno.

**Tensioni disponibili: 230Vac  $\pm 10\%$ , 400Vac  $\pm 10\%$ , 50/60 Hz (con alimentatore); 100Vdc  $\pm 10\%$ , 180Vdc  $\pm 10\%$  (con opzione SD).**



### M9.3 Dati tecnici freni FD

Nella tabella sottostante sono riportati i dati tecnici dei freni in c.c. tipo FD.

(F34)

Freno	Coppia frenante $M_b$ [Nm]			Rilascio		Frenatura		$W_{max}$ per frenata			W [MJ]	P [W]
	molle			$t_1$	$t_{1s}$	$t_2$	$t_{2c}$	[ J ]				
	6	4	2	[ms]	[ms]	[ms]	[ms]	10 s/h	100 s/h	1000 s/h		
FD02	–	3.5	1.75	30	15	80	9	4500	1400	180	15	17
FD03	5	3.5	1.75	50	20	100	12	7000	1900	230	25	24
FD53	7.5	5	2.5	60	30	100	12					
FD04	15	10	5	80	35	140	15	10000	3100	350	30	33
FD14												
FD05	40	26	13	130	65	170	20	18000	4500	500	50	45
FD15	40	26	13	130	65	170	20					
FD06S	60	40	20	–	80	220	25	20000	4800	550	70	55
FD56	–	75	37	–	90	250	20	29000	7400	800	80	65
FD06		100	50		100	250	20					
FD07	150	100	50	–	120	200	25	40000	9300	1000	130	65
FD08*	250	200	170	–	140	350	30	60000	14000	1500	230	100
FD09**	400	300	200	–	200	450	40	70000	15000	1700	230	120
FD20	260			100	170	340	–	80000	1700	1800	–	100
FD25	400			120	195	390	–	120000	19000	2000	–	110
FD30	1000			180	210	420	–	200000	28000	2900	–	200
FD160	1600			360	245	490	–	240000	36000	2600	–	336
FD250	2500			420	343	685	–	280000	47000	3700	–	400
FD400	4000			530	455	910	–	325000	51000	4500	–	420
FD8	400			176	78	236	–	65000	7000	650	–	85
FD9	600			324	138	176	–	120000	12000	1200	–	100
FD10	800			480	194	172	–	100000	16000	2000	–	150
FD1000	1000			252	–	375	–	220000	27000	2700	–	300
FD1600	1600			366	–	498	–	230000	35000	3500	–	340
FD2500	2500			660	–	880	–	590000	61000	6100	–	530

\* valori di coppia frenante ottenuti con n° 9, 7, 6 molle rispettivamente

\*\* valori di coppia frenante ottenuti con n° 12, 9, 6 molle rispettivamente

$t_1$  = tempo di rilascio del freno con alimentatore a semionda  
 $t_{1s}$  = tempo di rilascio del freno con alimentatore a controllo elettronico dell'eccitazione  
 $t_2$  = ritardo di frenatura con interruzione lato c.a. e alimentazione separata  
 $t_{2c}$  = ritardo di frenatura con interruzione lato c.a. e c.c. – I valori di  $t_1$ ,  $t_{1s}$ ,  $t_2$ ,  $t_{2c}$  indicati nella tabella sono riferiti al freno tarato alla coppia massima, traferro medio e tensione nominale  
 $W_{max}$  = energia max per frenata  
W = energia di frenatura tra due regolazioni successive del traferro  
 $P_b$  = potenza assorbita dal freno a 20°C  
 $M_b$  = coppia frenante statica ( $\pm 15\%$ )  
s/h = avviamenti orari

L'usura delle guarnizioni di attrito è funzione delle condizioni operative (temperatura, umidità, velocità di slittamento, pressione specifica); i valori di usura devono pertanto essere considerati come indicativi.

### M9.4 Collegamenti freno FD

I motori standard ad una velocità sono forniti con il collegamento del raddrizzatore alla morsetteria motore già realizzato in fabbrica. Per motori a 2 velocità, e dove è richiesta l'alimentazione del freno separata, prevedere il collegamento al raddrizzatore in accordo alla tensione freno VB indicata nella targhetta del motore. **Data la natura induttiva del carico, per il comando del freno e per l'interruzione lato corrente continua devono essere utilizzati contatti con categoria d'impiego AC-3 secondo IEC 60947-4-1.**



Tabella (F35+F39) - Bobina freno con alimentazione da morsetti del motore (DIR) ed interruzione lato a.c. Tempo di arresto  $t_2$  ritardato e funzione delle costanti di tempo del motore. Da prevedere quando sono richiesti avviamenti/arresti progressivi.

Tabella (F36+F40) - Bobina freno con alimentazione separata (SA) ed interruzione lato c.a.

Tempo di arresto normale ed indipendente dal motore.

Si realizzano i tempi di arresto  $t_2$  indicati nella tabella (F34).

Tabella (F37+F41) - Bobina freno con alimentazione da morsetti del motore (DIR) ed interruzione lato c.a. e c.c.

Arresto rapido con i tempi d'intervento  $t_{2c}$  indicati in tabella (F34).

Tabella (F38+F42) - Bobina freno con alimentazione separata (SA) ed interruzione lato c.a. e c.c.

Tempo di arresto ridotto secondo i valori  $t_{2c}$  indicati in tabella (F34).

L'alimentazione del freno direttamente dalla morsettiera del motore (tab. F35-F39 e tab. F37-F41) è possibile solo quando la tensione nominale del freno corrisponde alla tensione minore del motore.

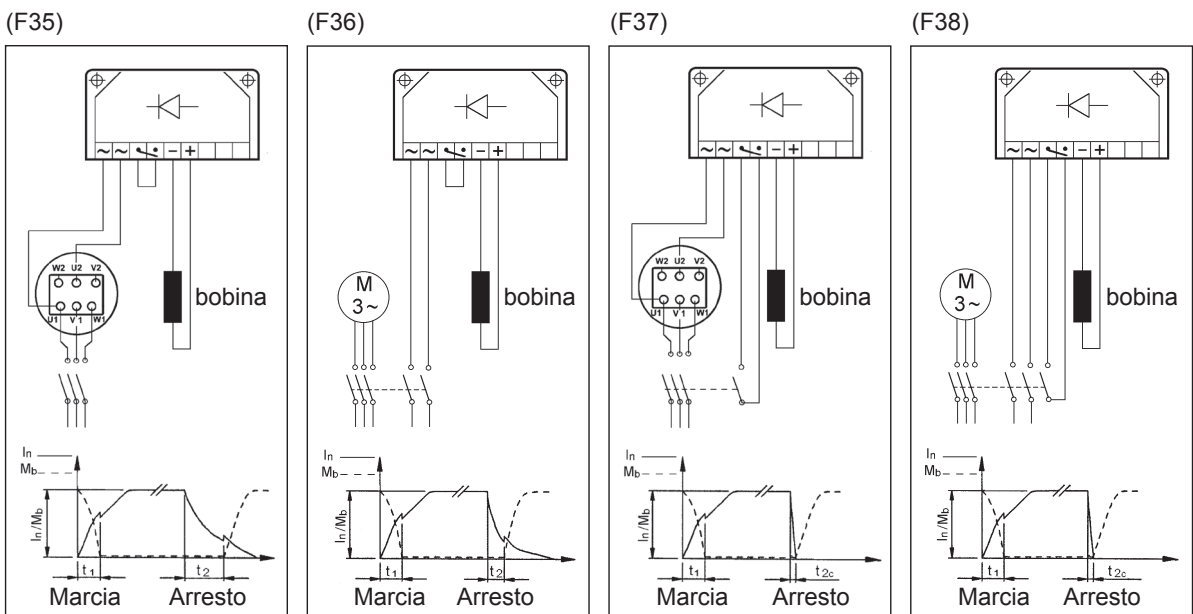

Per i motori BXN e MXN lo schema di collegamento del freno FD è il seguente:

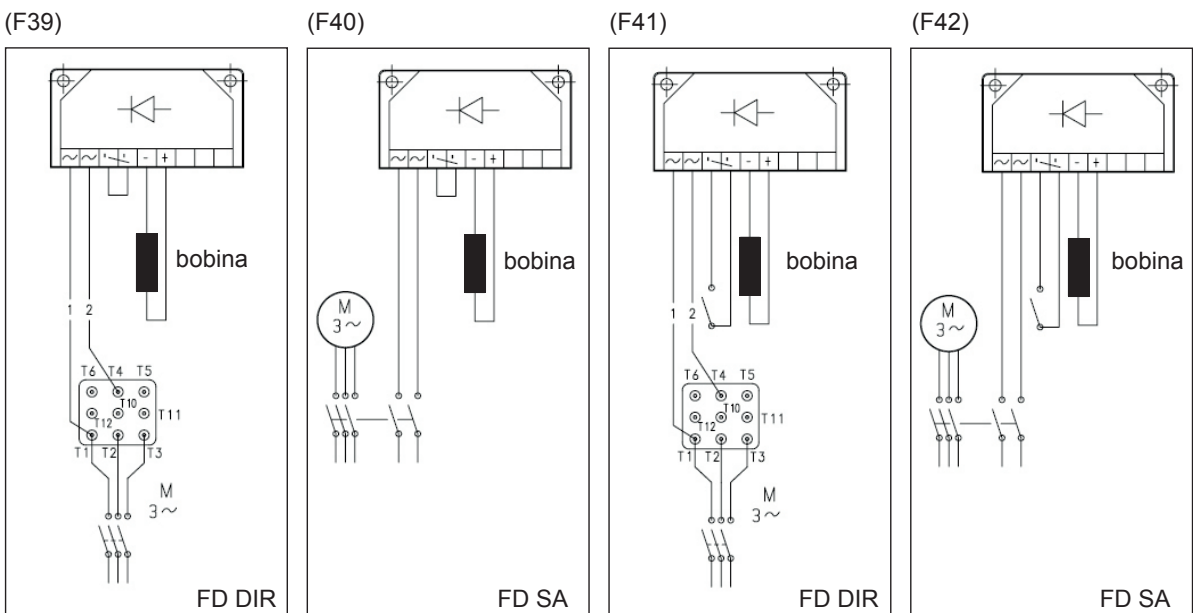



## M10 MOTORI AUTOFRENANTI IN C.A., TIPO BXN-BX-BE-BN\_FA e MXN-MX-ME-M\_FA

**Grandezze:** BXN 63 ... BXN 90, BX 80 ... BX 160L - BE 63 ... BE 160L - BN 63 ... BN 180M / MXN 05 ... MXN 25 - MX2SB ... MX5LA - ME05 ... ME5 - M05 ... M5

(F43)

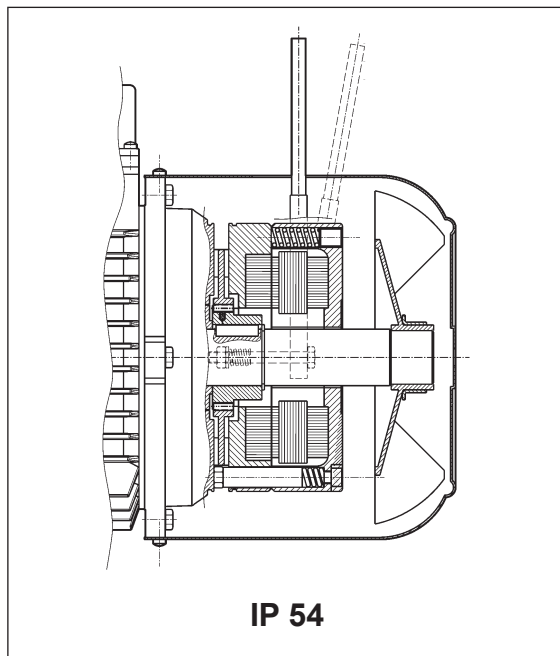

**IP 54**

(F44)

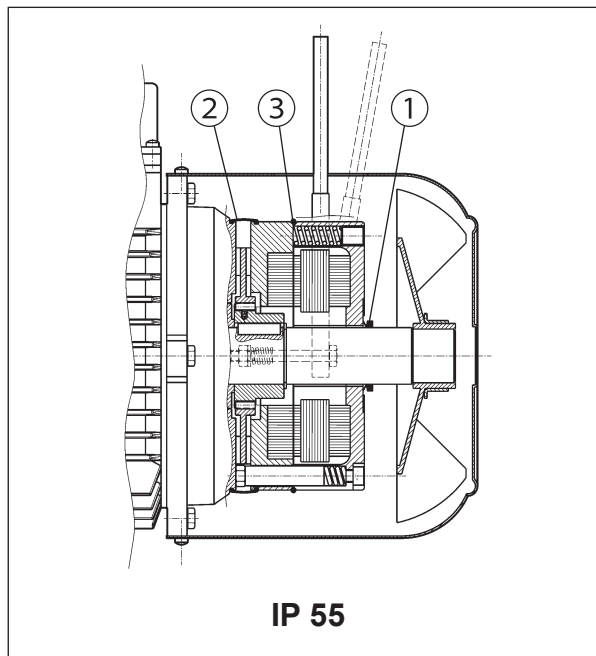

**IP 55**

Freno elettromagnetico con alimentazione in corrente alternata trifase, fissato con viti allo scudo motore; le molle di precarico realizzano il posizionamento assiale del corpo magnete.

Il disco freno è scorrevole assialmente sul mozzo trascinatore in acciaio calettato sull'albero e provvisto di dispositivo antivibrazione.

La coppia frenante è pre-impostata in fabbrica su valori che sono indicati nelle tabelle dati tecnici dei relativi motori.

L'azione del freno è inoltre modulabile, regolando con continuità la coppia frenante, tramite le viti che realizzano il precarico delle molle; il campo di regolazione della coppia è:  $30\% M_{bMAX} < M_b < M_{bMAX}$  ( $M_{bMAX}$  è il momento frenante max riportato in tab. (F45).

Il freno tipo FA presenta dinamiche molto elevate che lo rendono idoneo in applicazioni dove sono richieste frequenze di avviamento elevate con tempi d'intervento molto rapidi.

A richiesta, i motori possono essere previsti di leva per lo sblocco manuale con ritorno automatico (R). Per la posizione angolare della leva di sblocco vedi descrizione della relativa variante al paragrafo "SISTEMI DI SBLOCCO FRENO".

**Per applicazioni che prevedono sollevamenti e/o elevati valori di lavoro orario smaltibile, contattare il servizio tecnico commerciale.**

### M10.1 Grado di protezione

L'esecuzione standard prevede il grado di protezione IP54.

In opzione, il motore autofrenante FA viene fornito con grado di protezione **IP55** prevedendo le seguenti varianti costruttive:

- ① anello V-ring posizionato sull'albero motore N.D.E.
- ② protezione in gomma impermeabile e antipolvere
- ③ anello O-ring



## M10.2 Alimentazione freno FA

Nei motori a singola polarità l'alimentazione della bobina freno può derivare direttamente dalla morsetteria motore e la tensione del freno quindi coincide con la tensione del motore.

Per i motori a doppia polarità, e per i motori con alimentazione separata del freno, è presente una morsetteria ausiliaria con 6 terminali per il collegamento alla linea del freno. In tutti i casi il valore di tensione del freno dovrà essere specificato in designazione. Nella tabella seguente sono riportate le condizioni di alimentazione standard del freno in c.a. per i motori a singola e doppia polarità:

(F45)

Tensione Alimentazione Freni V	Freno FA	
	Alimentazione Motore a 50Hz	Alimentazione Motore a 60Hz
208	✗	✓
220	✗	✓
230	✓	✓
240	✗	✓
380	✓	✓
400	✓	✓
415	✓	✗
440	✗	✓
460	✗	✓
480	✗	✓
500	✓	✗
575	✗	✓

**NOTA:** Per i motori BXN e MXN fare riferimento al catalogo EVOX

Su richiesta, sono disponibili tensioni speciali.

## M10.3 Dati tecnici freni FA

(F46)

Freno	Coppia frenante $M_b$ [Nm]	Rilascio $t_1$ [ms]	Frenatura $t_2$ [ms]	$W_{max}$ [ J ]			W [MJ]	P [VA]
				10 s/h	100 s/h	1000 s/h		
FA 02	3.5	4	20	4500	1400	180	15	60
FA 03	7.5	4	40	7000	1900	230	25	80
FA 04	15	6	60	10000	3100	350	30	110
FA 14								
FA 05	40	8	90	18000	4500	500	50	250
FA 15								
FA 06S	60	16	120	20000	4800	550	70	470
FA 06	75	16	140	29000	7400	800	80	550
FA 07	150	16	180	40000	9300	1000	130	600
FA 08	250	20	200	60000	14000	1500	230	1200

$M_b$  = max coppia frenante statica ( $\pm 15\%$ )  
 $t_1$  = tempo di rilascio freno  
 $t_2$  = ritardo di frenatura  
 $W_{max}$  = energia max per frenata (capacità termica del freno)  
W = energia di frenatura tra due regolazioni successive del traferro  
 $P_b$  = potenza assorbita dal freno a 20° (50 Hz)  
s/h = avviamenti orari

N.B.  
I valori di  $t_1$  e  $t_2$  riportati in tabella sono riferiti al freno tarato alla coppia nominale, traferro medio e tensione nominale.



L'usura delle guarnizioni di attrito è funzione delle condizioni operative (temperatura, umidità, velocità di slittamento, pressione specifica); i valori di usura devono pertanto essere considerati come indicativi.

#### M10.4 Collegamenti freno FA

Per i motori con alimentazione del freno derivata direttamente dall'alimentazione motore i collegamenti alla morsettiera corrispondono a quanto riportato nello schema seguente:

(F47)

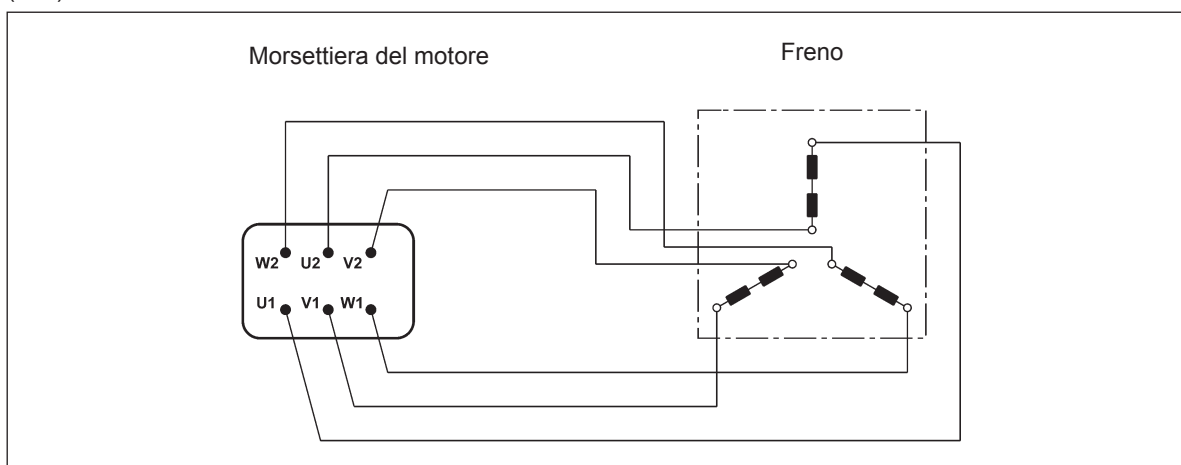

Per i motori BXN e MXN lo schema di collegamento del freno FA è il seguente:

(F48)

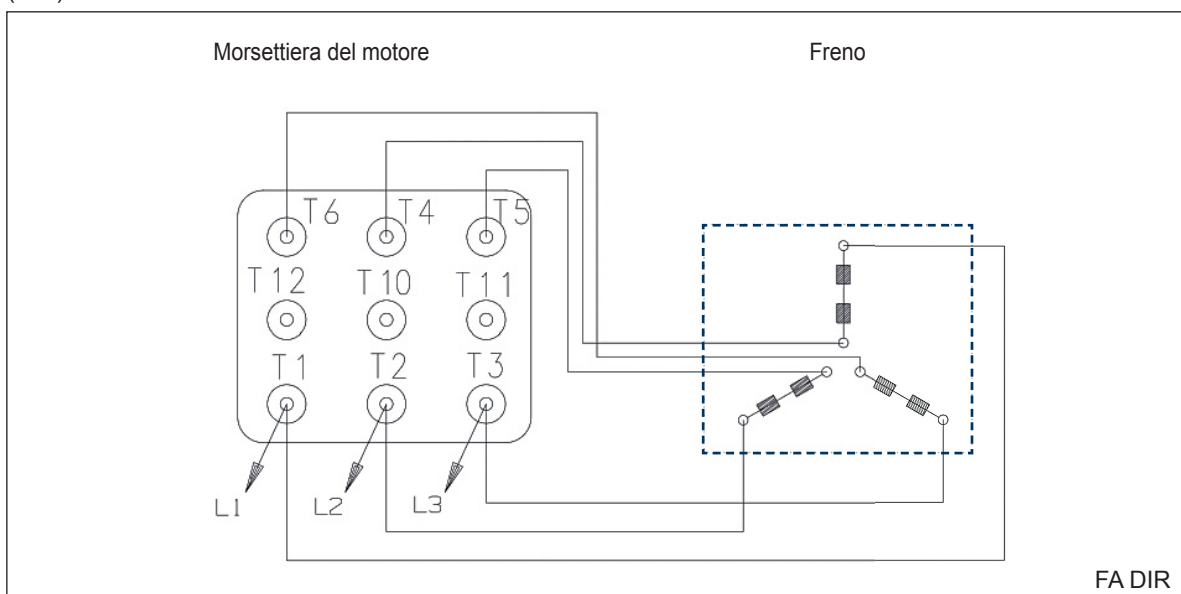



Per i motori a doppia polarità e, quando richiesto, per i motori ad una velocità con alimentazione da linea separata è prevista una morsetteria ausiliaria a 6 morsetti per il collegamento del freno; in questa esecuzione i motori prevedono la scatola coprimorsetti maggiorata. Vedi schema seguente:

(F49)

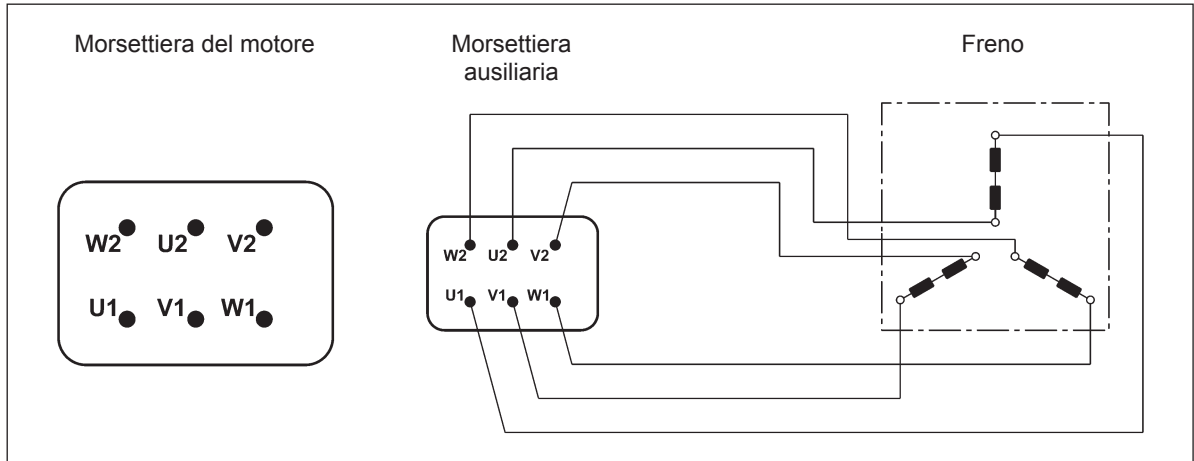

Per i motori BXN e MXN lo schema di collegamento del freno FA è il seguente:

(F50)

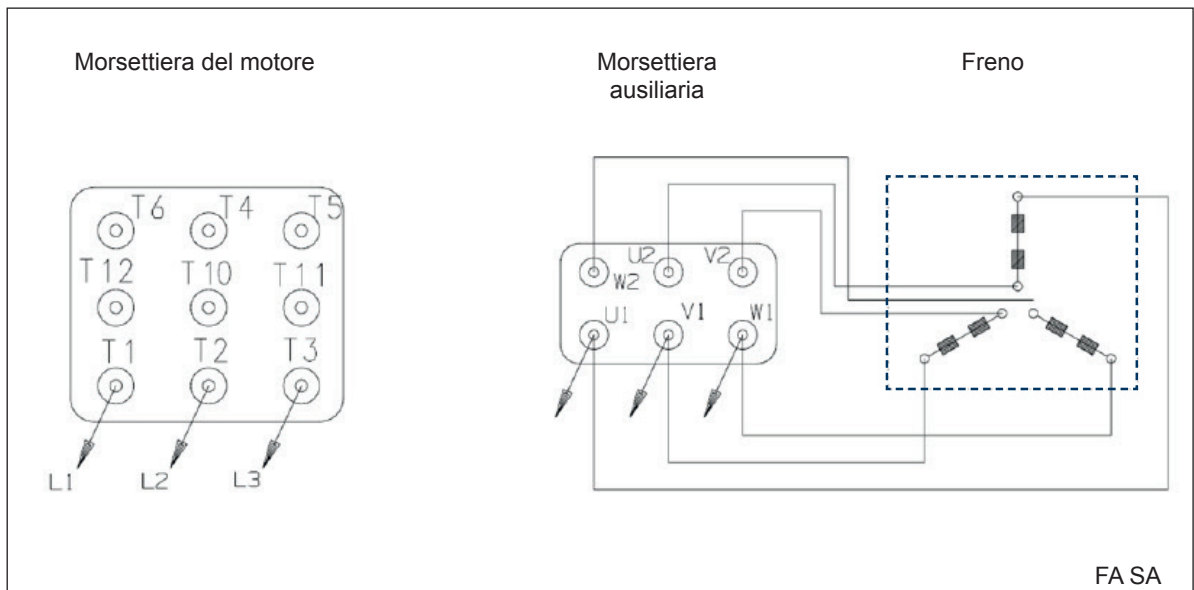





## M11 SISTEMI DI SBLOCCO FRENO

I freni a pressione di molle tipo FD e FA possono essere dotati opzionalmente di dispositivi per lo sblocco manuale del freno, normalmente utilizzati per condurre interventi di manutenzione sulle parti di macchina, o dell'impianto, comandate dal motore.

**R**

(F51)

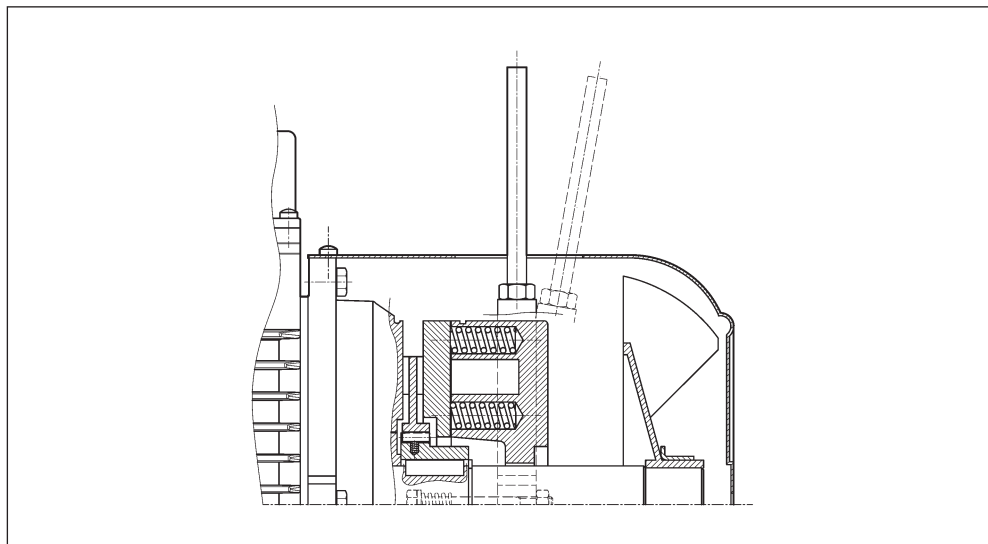

La leva di sblocco è dotata di ritorno automatico, tramite dispositivo a molla.

**RM**

(F52)

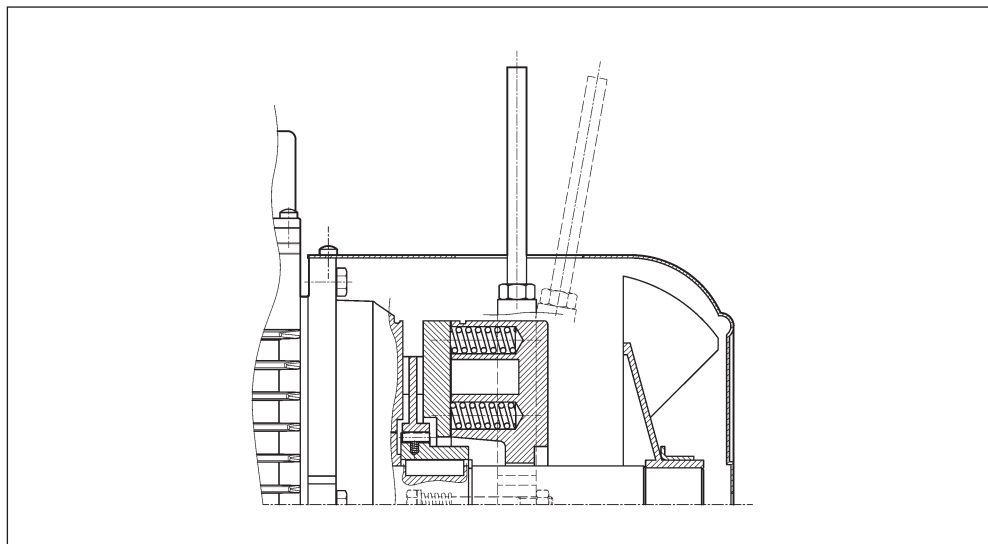

Sui motori con freno tipo FD la leva di sblocco può essere temporaneamente bloccata in posizione di rilascio del freno, avvitando la stessa fino ad impegnarne l'estremità in un risalto del corpo del freno.

La disponibilità dei sistemi di sblocco freno è diversa per i vari tipi di motore, ed è descritta dalla tabella seguente:



(F53)

	R	RM
BXN_FD BX_FD BE_FD BN_FD	BXN 63 ... BXN 90 BX 80 ... BX 180 BX 200K ... BX 315K BE 63 ... BE 180 BN 63 ... BN 200	BXN 63 ... BXN 90 BX 80 ... BX 132 BE 63 ... BE 132 BN 63 ... BN 132 ● FD07
MXN_FD MX_FD ME_FD M_FD	MXN05 ... MXN20 MX2 ... MX5 ME05 ... ME5 M05 ... M5	MXN05 ... MXN20 MX2 ... MX4 ME05 ... ME4 M05 ... M4LA
BXN_FA BX_FA BE_FA BN_FA	BXN 63 ... BXN 90 BX 80 ... BX 160 BE 63 ... BE 160L BN 63 ... BN 180M	●
MXN_FA MX_FA ME_FA M_FA	MXN05 ... MXN20 MX2 ... MX5 ME05 ... ME5 M05 ... M5	●

### M11.1 Orientamento della leva di sblocco

Per entrambe le opzioni **R** e **RM**, la leva di sblocco del freno viene collocata, se non diversamente specificato, con orientamento di 90° in senso orario, rispetto alla posizione della morsetteria - riferimento **[AB]** nel disegno sottostante. Orientamenti alternativi, tipo **[AA]**, **[AC]** e **[AD]** possono essere richiesti citandone la relativa specifica:

(F54)

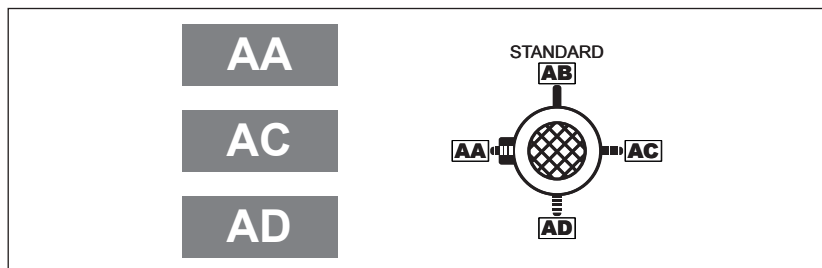

### M11.2 Alimentazione separata del freno

#### DIR

#### Alimentazione diretta del freno

L'alimentazione dell'impianto frenante avviene direttamente tramite l'alimentazione della morsetteria del motore elettrico. Quando un motore legacy è configurato con una diretta alimentazione del freno non è necessario selezionare alcuna opzione, mentre per i motori EVOX è necessario selezionare l'opzione DIR.

#### ...SA

#### Alimentazione freno CA separata

La bobina del freno è alimentata direttamente tramite una linea indipendente, separata da quella del motore. **FA-SA**: è necessario specificare la tensione CA nominale. SA 230 (Vc.a.). **FD-NB/SB-SA**: deve essere specificata la tensione alternata nominale che alimenta il raddrizzatore. Per esempio SA 400 (Vc.a.).

#### ...SD

#### Alimentazione freno CC separata

La bobina del freno è alimentata direttamente con una corrente continua e il raddrizzatore non è presente. La tensione nominale della bobina deve essere specificata, ad es. SD 24 (Vc.c.).

Nota: per BX≥200 e BX≥200K non è possibile alimentare il freno direttamente dalla morsetteria del motore, è quindi necessario selezionare l'opzione SA o SD.





## M12 OPZIONI

### M12.1 Avviamento progressivo

#### F1

Per applicazioni che richiedono progressività nelle fasi di avvio e di arresto è disponibile un volano - opzione F1 - la cui inerzia aggiuntiva assorbe energia cinetica durante l'avviamento e la restituisce in frenatura, rendendo i transitori più progressivi e gradualmente. Il volano è disponibile per i motori autofrenanti del tipo BN-BE\_FD e M-ME\_FD con caratteristiche specifiche dettagliate nella tabella che segue:

(F55)

Dati tecnici volano per motori tipo: BN-BE_FD, M-ME_FD			
		Peso volano [Kg]	Inerzia volano [Kgm <sup>2</sup> ]
BN 63 - BE 63	M05 - ME05	0.69	0.00063
BN 71 - BE 71	M1 - ME1	1.13	0.00135
BN 80 - BE 80	M2 - ME2	1.67	0.00270
BN 90 S - BN 90 L BE 90 S - BE 90 LA	-	2.51	0.00530
BN 100 - BE 100	M3 - ME3	3.48	0.00840
BN 112 - BE 112	-	4.82	0.01483
BN 132 S - BN 132 M BE 132 S - BE 132 M	M4 - ME4	6.19	0.02580

### M12.2 Filtro capacitivo

#### CF

Per i soli motori autofrenanti con freno tipo FD è disponibile in opzione il filtro capacitivo. Se corredati dell'opportuno filtro capacitivo a monte del raddrizzatore (opzione CF) i motori rientrano nei limiti di emissione previsti dalla Norma EN 61000-6-3:2007 "Compatibilità elettromagnetica – Norma Generica sull'emissione – Parte 6-3: Ambienti residenziali, commerciali e dell'industria leggera". I motori BX $\geq$ 200LA e BX $\geq$ 200LAK rientrano nei limiti di emissione previsti dalla Norma EN 61000-6-3:2007 "Compatibilità elettromagnetica – Norma Generica sull'emissione – Parte 6-3: Ambienti residenziali, commerciali e dell'industria leggera" senza l'ausilio del filtro capacitivo.

### M12.3 Protezioni termiche

Oltre alla protezione garantita dall'interruttore magnetotermico, i motori possono essere provvisti di sonde termiche incorporate per proteggere l'avvolgimento da eccessivo riscaldamento dovuto a scarsa ventilazione o servizio intermittente.

Questa protezione dovrebbe sempre essere prevista per motori servoventilati (IC416).

### M12.4 Sonde termiche a termistori

#### E3

Sono dei semiconduttori che presentano una rapida variazione di resistenza in prossimità della temperatura nominale di intervento (150 °C). L'andamento della caratteristica  $R = f(T)$  è normalizzato dalle Norme DIN 44081, IEC 34-11. In genere vengono impiegati termistori a coefficiente di temperatura positivo denominati anche "resistori a conduttore freddo" PTC. I termistori non possono comandare direttamente i relais e devono pertanto essere collegati ad un'adeguata apparecchiatura di sgancio. Con questa protezione vengono inseriti tre PTC, (collegati in serie), nell'avvolgimento con terminali disponibili in morsettiera ausiliaria.



## K1

Sono un sottogruppo dei termistori PTC le cui caratteristiche costruttive ne permettono l'impiego come sensori di temperatura aventi un coefficiente di temperatura positivo funzione della resistenza. La temperatura di esercizio è: 0°C ... +260°C. I termistori non possono comandare direttamente i relais e devono pertanto essere collegati ad un'adeguata apparecchiatura di sgancio. I terminali (polarizzati) di n.1 KTY 84-130 sono disponibili in una morsettiera ausiliaria.

### M12.5 Sonde termiche bimetalliche

## D3

I protettori di questo tipo contengono all'interno di un involucro un disco bimetallico che, raggiunta la temperatura nominale di intervento (150 °C), commuta i contatti dalla posizione di riposo. Con la diminuzione della temperatura, il disco e i contatti riprendono automaticamente la posizione di riposo. Normalmente si impiegano tre sonde bimetalliche in serie con contatti normalmente chiusi e terminali disponibili in una morsettiera ausiliaria.

### M12.6 Termometro a resistenza

## Pt1000

La termoresistenza è dotata di un chip per un sensore di temperatura, la cui resistenza cambia in funzione della temperatura secondo una serie di valori base riproducibili. Le variazioni di resistenza vengono trasferite come variazioni di corrente.

A 0°C, le misure delle resistenze sono regolate a 1000 ohm per il Pt1000 e corrispondono alla classe di precisione B (cioè il rapporto tra resistenza e temperatura). Lo scostamento limite è di  $\pm 0,3^\circ\text{C}$  e gli scostamenti ammissibili sono definiti nella norma EN 60751. La termoresistenza Pt1000, in futuro, sostituirà gradualmente la temperatura KTY84-130 oggi disponibile. La relazione tra la temperatura e la resistenza elettrica dei conduttori viene utilizzata nel Pt1000 per misurare la temperatura, proprio come con le termoresistenze aggiuntive sopra descritte. I metalli puri subiscono maggiori variazioni di resistenza rispetto alle leghe e hanno un coefficiente di temperatura relativamente costante.

### M12.7 Motore con connettore

## CON

Sono disponibili tre tipi di connettori (CON 1, CON 2, CON 3) che possono essere installati in due posizioni di montaggio: lato destro scatola coprimorsettiera (C1D, C2D, C3D); lato sinistro scatola coprimorsettiera (C1S, C2S, C3S). L'opzione CON è prevista per i motori BN e M a singola polarità (2, 4, 6, 8, poli) e BX/BE e MX/ME nelle grandezze indicate nella tabella seguente. Sono escluse tutte le versioni con doppia polarità. I connettori sono disponibili per i motori BX-BE/MX-ME e BN/M nella versione senza freno e per i motori autofrenanti dotati di freno in corrente continua FD, nelle grandezze indicate nella tabella seguente.

**Sul motore è fissato il connettore maschio (dotato di pin), il connettore femmina è escluso dalla fornitura. Con l'opzione CON è sempre previsto il collegamento a Y delle fasi.**

Per motori provvisti di servoventilazione (opzione U1) l'alimentazione del ventilatore è prevista nella scatola morsettiera separata fissata al copriventola. Nei motori dotati di encoder (opzioni EN1...EN6) i terminali della connessione dell'encoder avviene tramite cavo volante non connesso al connettore.

L'opzione CON non è applicabile ai motori dotati di freno in corrente alternata FA.

L'opzione CON non è compatibile con le opzioni U2, CUS, IC.



## Dati tecnici

(F56)

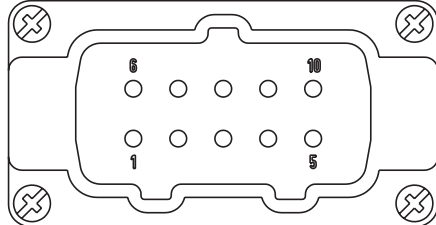
Opzione	CON 1
Grandezza motore	<b>BX 80 ... BX 112 / MX2, MX3 / BE 63 ... BE 112 / ME05 ... ME4 BN 63 ... BN 112 / M05 ... M3</b>
Vista connettore	
Tipo di connettore	Harting Han 10ES
Corpo connettore	Han EMC 10B con 2 leve
Numero di pins - corrente nominale	10 x 16A
Tensione di alimentazione	500 Vac
Tipo di connessione contatti	Terminali con vite

(F57)

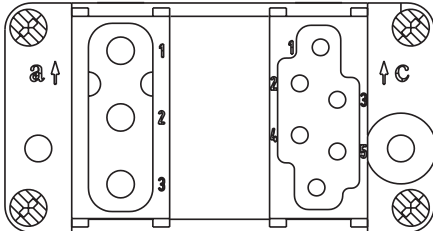
Opzione	CON 2
Grandezza motore	<b>BX 80 ... BX 132 / MX2, MX3 / BE 63 ... BE 132 / ME05 ... ME4 BN 63 ... BN 160MR / M05 ... M4</b>
Vista connettore	
Tipo di connettore	Harting Han Modular
Corpo connettore	Han EMC 10B con 2 leve
Tipo Moduli	Modulo C + Modulo vuoto + Modulo E
Numero di pins - corrente nominale	3 x 36A / 6 x 16A
Tensione di alimentazione	500 Vac
Tipo di connessione contatti	Contatti a crimpare

(F58)

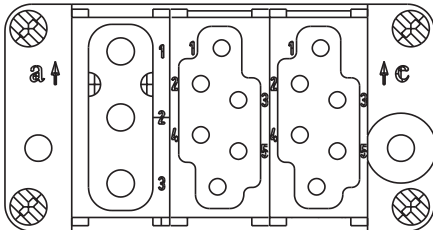
Opzione	CON 3
Grandezza motore	<b>BX 80 ... BX 132M / MX2, MX3 / BE 63 ... BE 132 / ME05 ... ME4 / BN 63 ... BN 160MR / M05 ... M4</b>
Vista connettore	
Tipo di connettore	Harting Han Modular
Corpo connettore	Han EMC 10B con 2 leve
Tipo Moduli	Modulo C + Modulo E + Modulo E
Numero di pins - corrente nominale	3 x 36A / 6 + 6 x 16A
Tensione di alimentazione	500 Vac
Tipo di connessione contatti	Contatti a crimpare



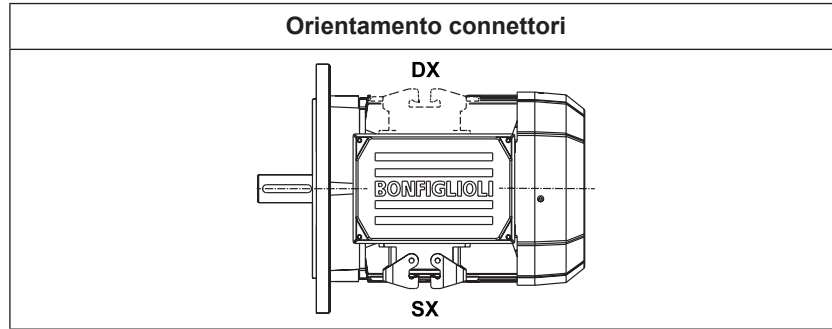

(F59)



(F60)



**Dimensioni d'ingombro motori senza freno**

		AD (mm)	AF (mm)	AH (mm)	LL (mm)	V <sup>(*)</sup> (mm)
<b>BE 63 - BN 63</b>	<b>ME05 - M05</b>	136	110	45	165	4.5
<b>BE 71 - BN 71</b>	<b>ME1 - M1</b>	149	110	45	165	15.5
<b>BX 80 - BE 80 - BN 80</b>	<b>MX2 - ME2 - M2</b>	160	110	45	165	16.5
<b>BX 90 - BE 90 - BN 90</b>	<b>MX3</b>	162	110	45	165	31.5
<b>BX 100 - BE 100 - BN 100</b>	<b>MX3 - ME3 - M3</b>	171	110	45	165	37.5
<b>BX 112 - BE 112 - BN 112</b>	<b>MX4</b>	186	110	45	165	39
<b>BX 132 - BE 132 - BN 132</b>	<b>MX4 - ME4 - M4</b>	210	140	45	188	45.5
<b>BN 160MR</b>	—	210	140	45	188	161

(\*) Dimensione valida solo per motori BX, BE e BN

(F61)

**Dimensioni d'ingombro motori con freno FD**

		AD (mm)	AF (mm)	AH (mm)	LL (mm)	V <sup>(*)</sup> (mm)
<b>BE 63 - BN 63</b>	<b>ME05 - M05</b>	136	110	45	165	4.5
<b>BE 71 - BN 71</b>	<b>ME1 - M1</b>	149	110	45	165	1.5
<b>BX 80 - BE 80 - BN 80</b>	<b>MX2 - ME2 - M2</b>	160	110	45	165	18.5
<b>BX 90 - BE 90 - BN 90</b>	—	162	110	45	165	39.5
<b>BX 100 - BE 100 - BN 100</b>	<b>MX3 - ME3 - M3</b>	171	110	45	165	63.5
<b>BX 112 - BE 112 - BN 112</b>	—	186	110	45	165	75
<b>BX 132 - BE 132 - BN 132</b>	<b>MX4 - ME4 - M4</b>	210	140	45	188	122
<b>BN 160MR</b>	—	210	140	45	188	161

(\*) Dimensione valida solo per motori BX e BN



## M12.8 Controllo della funzionalità del freno

### MSW

Il microinterruttore può essere regolato per segnalare l'attrazione/rilascio dell'ancora mobile o per segnalare il raggiungimento del massimo valore ammissibile per il traferro.

**L'opzione MSW è disponibile per i freni FD03...FD09.**

Il microswitch è dotato di tre terminali NC, NO, COM. Nella figura sottostante sono raffigurati i principali componenti del freno equipaggiato con microswitch.

(F62)

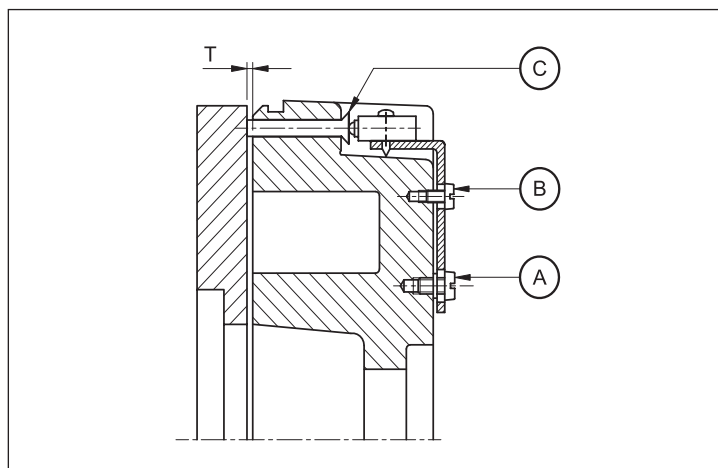

- A: Viti di fissaggio
- B: Vite di regolazione
- C: Attuatore

## M12.9 Ingresso cavi supplementare per motori autofrenanti

### IC

Sulla scatola coprimorsettiera dei motori autofrenanti BN 63 ... BN 160MR - M05 ... M4L sono disponibili due ingressi cavo supplementari M16 x 1.5 (uno per lato).

Sulla scatola coprimorsettiera dei motori autofrenanti BN 160 ... BN 200 - M5 è disponibile un ingresso cavo supplementare M16 x 1.5 affiancato all'ingresso cavo freno.

## M12.10 Riscaldatori anticondensa

### H1

### NH1

I motori funzionanti in ambienti molto umidi e/o in presenza di forti escursioni termiche, possono essere equipaggiati con una resistenza anti-condensa.

L'alimentazione monofase è prevista da morsettiera ausiliaria posta nella scatola principale.

Le potenze assorbite dalla resistenza elettrica sono elencate qui di seguito:

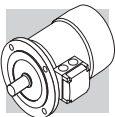

(F63)

	H1	NH1
	1~ 230V ± 10% P [W]	1~ 115V ± 10% P [W]
<b>BXN 63 ... BXN 80</b> <b>BX 80</b> <b>BE 63 ... BE 80</b> <b>BN 56 ... BN 80</b>	10	10
<b>BXN 90</b> <b>BX 90 ... BX 132</b> <b>BE 90 ... BE 132MB</b> <b>BN 90 ... BN 160MR</b>	25	25
<b>BX 160...BX 250</b> <b>BX 160 ... BX 250K</b> <b>BX 160, BX 180</b> <b>BE 160, BE 180</b> <b>BN 160, BN 200</b>	50	50
<b>BX 280</b> <b>BX 280K</b>	60	60
<b>BX 315 ... BX 355</b> <b>BX 315K ... BX 355K</b>	120	120

**Importante! Durante il funzionamento del motore la resistenza anticondensa non deve mai essere inserita.**

#### M12.11 Tropicalizzazione

**TP**

Su richiesta, mediante la specifica dell'opzione **TP**, gli avvolgimenti del motore ottengono una protezione aggiuntiva che li rende idonei al funzionamento in condizioni di elevata temperatura e umidità.

#### M12.12 Seconda estremità d'albero

**PS**

L'opzione esclude le varianti RC, TC, U1, U2, EN1, EN2, EN3, EN4, EN5, EN6, EN7, EN8. Le dimensioni sono reperibili nelle tavole dimensionali dei motori.

(F64)

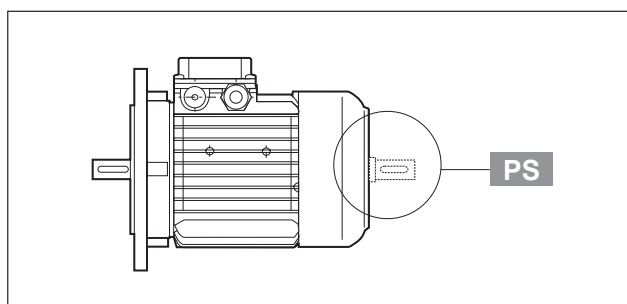



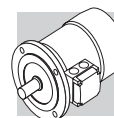

### M12.13 Dispositivo antiritorno

**AL**

**AR**

Nelle applicazioni dove è necessario impedire la rotazione inversa del motore dovuta all'azione del carico, è possibile impiegare motori provvisti di un dispositivo antiritorno (disponibile solo sulla serie MX/ME e M). Questo dispositivo, pur consentendo la libera rotazione nel senso di marcia, interviene istantaneamente in caso di mancanza di alimentazione bloccando la rotazione dell'albero nel senso inverso. Il dispositivo antiritorno è lubrificato a vita con grasso specifico per questa applicazione. In fase di ordine dovrà essere indicato chiaramente il senso di marcia previsto. In nessun caso il dispositivo antiritorno dovrà essere utilizzato per impedire la rotazione inversa nel caso di collegamento elettrico errato. Nella tabella (F62) sono indicate le coppie nominale e massima di bloccaggio attribuite ai dispositivi antiritorno utilizzati, mentre la raffigurazione schematica del dispositivo è inserita nella tabella (F63). Le dimensioni sono le stesse del motore autofrenante. Il senso di rotazione libera è descritto nel paragrafo "OPZIONI MOTORI" delle specifiche sezioni dedicate ai riduttori.

(F65)

	Coppia nominale di bloccaggio	Coppia max. di bloccaggio	Velocità di distacco
	[Nm]	[Nm]	[min <sup>-1</sup> ]
<b>ME1 - M1</b>	6	10	750
<b>MX2 - ME2 M2</b>	16	27	650
<b>MX3 - ME3 M3</b>	54	92	520
<b>MX4 - ME4 M4</b>	110	205	430

(F66)

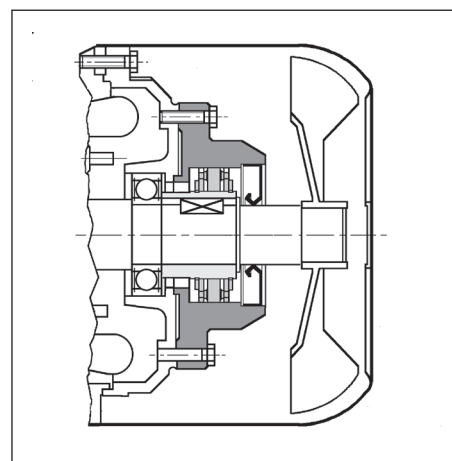

### M12.14 Equilibratura rotore

**RV**

Per esigenze di particolare silenziosità è disponibile l'esecuzione opzionale **RV** che garantisce vibrazioni ridotte, secondo il grado **B**.

La tabella sottostante riporta i valori della velocità efficace di vibrazione per equilibratura normale (A) e in grado B.

(F67)

Grado di vibrazione	Velocità di rotazione n [min <sup>-1</sup> ]	Limiti della velocità di vibrazione (mm/s) <b>BX 80 ≤ H ≤ BX 335M ≤ BX 355MK BE 63 ≤ H ≤ BE 180L BN 56 ≤ H ≤ BN 200</b>
<b>A</b>	600 < n < 3600	1.6
<b>B</b>	600 < n < 3600	0.70

I valori si riferiscono a misure con motore liberamente sospeso e funzionamento a vuoto; tolleranza ±10%.



## M12.15 Ventilazione

I motori sono raffreddati mediante ventilazione esterna (IC 411 secondo CEI EN 60034-6) e sono provvisti di ventola radiale in plastica, funzionante in entrambi i versi di rotazione.

L'installazione dovrà assicurare una distanza minima della calotta copriventola dalla parete più vicina, in modo da non creare impedimento alla circolazione dell'aria, oltre che permettere l'esecuzione della manutenzione ordinaria del motore e, se presente, del freno.



Il raffreddamento è realizzato per mezzo di un ventilatore assiale con alimentazione indipendente, montato sulla calotta copriventola (metodo di raffreddamento IC 416).

Questa esecuzione è utilizzata in caso di alimentazione del motore tramite inverter allo scopo di estendere il campo di funzionamento a coppia costante anche a bassa velocità, o quando per lo stesso sono richieste elevate frequenze di avviamento.

Da questa opzione sono esclusi i motori con doppia sporgenza d'albero (opzione PS).

Per la variante sono disponibili due esecuzioni alternative, denominate **U1** e **U2**, aventi lo stesso ingombro in senso longitudinale. Per entrambe le esecuzioni, la maggiore lunghezza della calotta copriventola ( $\Delta L$ ) è riportata nella tabella che segue. Dimensioni complessive ricavabili dalle tavole dimensionali dei motori.

(F68)

Tabella maggiorazione lunghezze motore			
		$\Delta L_1$	$\Delta L_2$
<b>BE 71 - BN 71</b>	<b>ME1 - M1</b>	93	32
<b>BX 80</b>	<b>MX2</b>	80	67
<b>BE 80 - BN 80</b>	<b>ME2 - M2</b>	125	55
<b>BX 90</b>	—	133	85
<b>BE 90 - BN 90</b>	—	133	49
<b>BX 100</b>	<b>MX3</b>	135	88
<b>BE 100 - BN 100</b>	<b>ME3 - M3</b>	119	30
<b>BX 112</b>	—	136	90
<b>BE 112 - BN 112</b>	—	130	33
<b>BX 132</b>	<b>MX4</b>	123	24
<b>BE 132 - BN 132</b>	<b>ME4 - M4</b>	160	51
<b>BX 160 - BX 180</b>	<b>MX5</b>	184	184
<b>BE 160 - BE 180</b>	<b>ME5</b>		
<b>BN 160 - BN 180 - BN 200</b>	<b>M5</b>		
<b>BX 200</b>	—	260	260
<b>BX 225 - BX 250</b>	—	320	320
<b>BX 280 - BX 315</b>	—	430	430
<b>BX 355</b>	—	640	640

$\Delta L_1$  = variazione dimensionale rispetto alla quota LB del motore standard corrispondente.

$\Delta L_2$  = variazione dimensionale rispetto alla quota LB del motore autofrenante corrispondente.

## U1

Terminali di alimentazione del ventilatore in scatola morsetti separata.

Nei motori autofrenanti grandezza BX 132 ... BX 160 - BE 71 ... BE 160 - BN 71 ... BN 160MR, MX4, MX5 - ME05 ... ME5 - M05 ... M5 con variante **U1**, la leva di sblocco non è collocabile nella posizione AA.

Questa opzione può essere selezionata per motori conformi agli standard CSA e UL (opzione CUS) solo per taglie  $BX \geq 200$  e  $BX \geq 200K$ .



(F69)

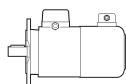

			V a.c. ±10%	Hz	P [W]	I [A]
<b>BN 71 - BE 71</b>	<b>ME1 - M1</b>		1 ~ 230	50 / 60	22	0.12
<b>BX 80 - BE 80</b> <b>BN 80</b>	<b>MX2 - ME2</b> <b>M2</b>				22	0.12
<b>BX 90 - BE 90</b> <b>BN 90</b>	—				40	0.30
<b>BX 100 - BE 100</b> <b>BN 100</b>	<b>MX3 - ME3</b> <b>M3</b>				50	0.25
<b>BX 112 - BE 112</b> <b>BN 112</b>	—				50	0.26 / 0.15
<b>BX 132 - BE 132</b> <b>BN 132 ... BN 160MR</b>	<b>MX4 - ME4</b> <b>M4L</b>				110	0.38 / 0.22
<b>BX 160 - BE 160</b> <b>BN 160M ... BN 180M</b>	<b>MX5 - ME5</b> <b>M5</b>		3 ~ 230Δ / 400Y	50	180	1.25 / 0.72
<b>BX 180 - BE 180</b> <b>BN 180L ... BN 200L</b>	—				250	1.51 / 0.87
<b>BX 200 ... BX 250</b> <b>BX 200K ... BX 250K</b>	—				250	0.64
<b>BX 280 ... BX 315M</b> <b>BX 280K ... BX 315MK</b>	—				750	1.7
<b>BX 315 ... BX 355S</b> <b>BX 315LK ... BX 355SK</b>	—				1500	3.3
<b>BX 355M</b> <b>BX 355MK</b>	—				3000	6.1

## U2

I terminali del ventilatore sono collocati nella scatola morsettiera principale del motore.  
L'opzione **U2** non è applicabile ai motori BX, BE, MX, ME e ai motori con opzione CUS (conformi alle norme CSA e UL).

(F70)

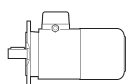

			V a.c. ±10%	Hz	P [W]	I [A]
<b>BN 71</b>	<b>M1</b>		1 ~ 230	50 / 60	22	0.12
<b>BN 80</b>	<b>M2</b>				22	0.12
<b>BN 90</b>	—				40	0.30
<b>BN 100</b>	<b>M3</b>		3 ~ 230Δ / 400Y		40	0.26 / 0.09
<b>BN 112</b>	—				50	0.26 / 0.15
<b>BN 132 ... BN 160MR</b>	<b>M4L</b>				110	0.38 / 0.22



### M12.16 Tettuccio parapigioggia

## RC

Il dispositivo parapigioggia, che è raccomandato quando il motore è montato verticalmente con l'albero verso il basso, serve a proteggere il motore stesso dall'ingresso di corpi solidi e dallo stillicidio. Le dimensioni aggiuntive sono indicate nella tabella sottostante.  
Il tettuccio esclude le varianti PS, EN1, EN2, EN3, EN4, EN5, EN6.



(F71)

		AQ	$\Delta V$
BE 63 - BN 63	ME05 - M05	118	24
BN 71 - BE 71	ME1 - M1	134	27
BX 80 - BE 80 BN 80	MX2 - ME2 M2	152	25
BX 90 - BE 90 BN 90	—	168	30
BX 100 - BE 100 BN 100	MX3 - ME3 M3	190	28
BX 112 - BE 112 BN 112	—	211	32
BX 132 - BE 132 BN 132 ... BN 160MR	MX4 - ME4 M4	254	32
BX 160 - BE 160 BN 160M ... BN 180M	MX5 - ME5 M5	302	36
BX 180 - BE 180 BN 180L ... BN 200L	—	340	36
BX 200	—	423	55
BX 225	—	465	55
BX 250	—	514	55
BX 280	—	567	100
BX 315	—	645	100
BX 355	—	740	120

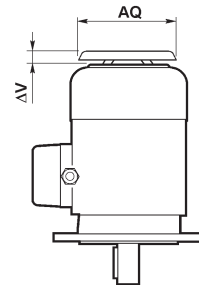

Per l'opzione RC/TC su motori BXN/MXN vedere lo schema seguente.

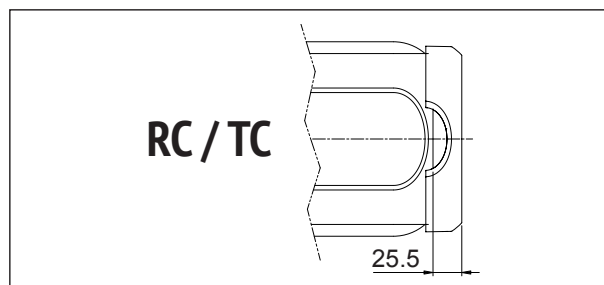

#### M12.17 Tettuccio tessile

**TC**

La variante del tettuccio tipo TC è da specificare quando il motore è installato in ambienti dell'industria tessile, dove sono presenti filamenti che potrebbero ostruire la griglia del copriventola, impedendo il regolare flusso dell'aria di raffreddamento.

L'opzione esclude le varianti EN1, EN2, EN3, EN4, EN5, EN6, PS, U1, U2. L'ingombro complessivo è lo stesso del tettuccio tipo RC.

L'opzione TC non è disponibile per i motori BX.

#### M12.18 Dispositivi di retroazione

I motori possono essere dotati di sei diversi tipi di encoder, qui di seguito descritti.

Il montaggio dell'encoder esclude le esecuzioni con doppia estremità d'albero (PS) e tettuccio di protezione (RC, TC).



## EN1

Encoder incrementale,  $V_{IN} = 5\text{ V}$ , uscita line-driver RS 422.

## EN2

Encoder incrementale,  $V_{IN} = 10\text{-}30\text{ V}$ , uscita line driver RS 422.

## EN3

Encoder incrementale,  $V_{IN} = 12\text{-}30\text{ V}$ , uscita push-pull 12-30 V

## EN4

Encoder sin/cos,  $V_{IN} = 4.5\text{-}5.5\text{ V}$ , uscita Sinus  $0.5V_{PP}$ .

## EN5

Encoder assoluto monogiro, interfaccia HIPERFACE®,  $V_{IN} = 7\text{-}12\text{ V}$ .

## EN6

Encoder assoluto multigiro, interfaccia HIPERFACE®,  $V_{IN} = 7\text{-}12\text{ V}$ .

## EN7

Encoder incrementale Heavy Duty,  $V_{IN} = 12\text{-}30\text{ V}$ , uscita push-pull 12-30 V.

## EN8

Encoder incrementale Heavy Duty,  $V_{IN} = 12\text{-}30\text{ V}$ , uscita push-pull 9-30 V.

Nota: EN7 ed EN8 disponibili solo per  $BX \geq 200$

(F72)

	EN1	EN2	EN3	EN4	EN5	EN6	EN7	EN8	
interfaccia	TTL/RS 422	TTL/RS 422	HTL push-pull	Sinus 0.5 VPP	HIPERFACE®	HIPERFACE®	HTL push-pull	HTL push-pull	
tensione alimentazione [V]	4...6	10...30	12...30	4.4...5.5	7...12	7...12	9...30		
tensione di uscita [V]	5	5	12...30	—	—	—	9...30		
corrente di esercizio senza carico [mA]	120	100	100	40	80	80	80		
n° di impulsi per giro	1024							2048	
risoluzione	—	—	—	—	15 bit	15 bit	-	-	
rivoluzioni	—	—	—	—	—	12 bit	-	-	
n° segnali	6 (A, B, Z + segnali invertiti)			6 (cos-, cos+, sin-, sin+, Z, Z̄)	—	—	6	6	
max. frequenza di uscita [kHz]	600			200			200		
max. velocità [min <sup>-1</sup> ]	6000 (9000 min <sup>-1</sup> per 10 s )							6000	
campo di temperatura di funzionamento [°C]	-30 ... +100							-20 ... +85	
grado di protezione	IP 65							IP67	



(F73)

EN1, EN2, EN3, EN4, EN5, EN6, EN7, EN8		
		<b>L4</b>
BN 63 ... BN 200	M05 ... M5	65
BE 63... BE180	ME05 ... ME5L	65
BX 80 ... BX 180	MX2 ... MX5L	65
BX 200 ... BX 280	—	100
BX 315 ... BX 355	—	100

(F74)

EN_ + U1		
		<b>L3</b>
BX 160 - BE 160 BN 160M...BN 180M	MX5 - ME5 M5	72
BX 160 - BE 180 BN 180L...BN 200L	—	82
BX 160_FD BN 160M_FD...BN 180M_FD	MX5_FD M5_FD	35
BX 180_FD BN 180L_FD...BN 200L_FD	—	41
BX 200 - BX 225 - BX 250	—	100
BX 280 - BX 315 - BX 355	—	150

Se l'opzione EN\_ è richiesta per motori di grandezza BX 80 ... BX 132 - MX2 ... MX4 - BE 63 ... BE 132 - ME05 ... ME4 - BN 71 ... BN 160MR - M1 ... M4, contemporaneamente all'opzione U1/U2, le variazioni dimensionali coincidono con quelle dell'opzione U1/U2.

Per l'opzione EN sui motori BXN/MXN vedere lo schema seguente.

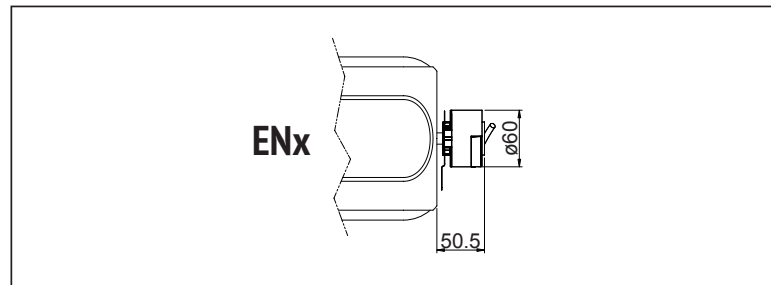

### M12.19 EC - Copertura dell'encoder

**EC**

L'opzione EC è una variante di copertura realizzata appositamente per i nostri encoder. Li protegge dagli impatti e può aiutare a prolungare la loro vita produttiva.

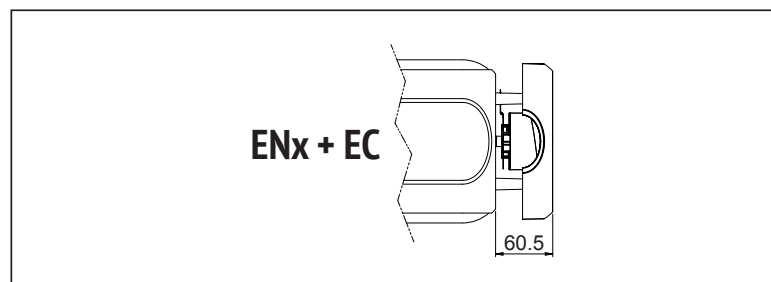

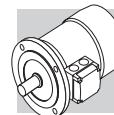

## M12.20 Cuscinetti Isolati

**IB**

NOTA: Questa opzione è disponibile per motori BX e BX K $\geq$ 280 ed è obbligatoria quando il motore viene alimentato mediante inverter. Quando l'opzione IB è selezionata il motore viene equipaggiato con cuscinetti isolati sul lato utilizzatore.

Questo previene il danneggiamento prematuro dei cuscinetti causato dalla circolazione di correnti ad alte frequenze.

## M12.21 Montaggio Verticale

**VM**

NOTA: Questa opzione è obbligatoria per i motori BX  $\geq$  200 e BX  $\geq$  200K se montati in verticale. Quando l'opzione VM viene selezionata il motore viene fornito con accorgimenti costruttivi addizionali. Inoltre, la posizione di montaggio verticale viene specificata in targhetta.

## M12.22 Protezione superficiale

**C\_**

I motori, che laddove non viene richiesta una classe di protezione specifica, nelle zone verniciate (ferrose) rispettano come requisito minimo la classe di protezione C2 (UNI EN ISO 12944-2), sono forniti con protezione superficiale C3 e C4 per una migliore resistenza alla corrosione atmosferica.

(F75)

PROTEZIONE SUPERFICIALE	Ambienti tipici	Temperatura superficiale max.	Classe di corrosività secondo UNI EN ISO 12944-2
<b>C3</b>	Ambienti urbani ed industriali, con umidità relativa dell'aria max.100% (inquinamento ambientale medio)	120°C	C3
<b>C4</b>	Aree industriali, zone costiere, impianti chimici, con umidità relativa dell'aria max.100% (inquinamento ambientale alto)	120°C	C4
<b>C5M</b>	Zone costiere e offshore con alto contenuto di sale.	120°C	C5M

I motori previsti con le protezioni opzionali C3 e C4 sono disponibili in diverse tinte.

Se non specificata nessuna tinta (vedere opzione "VERNICIATURA") la fornitura viene eseguita con la tinta RAL 7042 per BN/M, BE/ME e BX $\leq$ 180/MX e con la tinta Munsell blue 8B 4.5/3.25 per BX $\geq$ 200.

A richiesta sono fornibili motori per classe di corrosività C5 secondo UNI EN ISO 12944-2, contattando il ns. Servizio tecnico-Commerciale.



## M12.23 Verniciatura

### RAL

I motori previsti con le protezioni opzionali C3 e C4 sono disponibili in diverse tinte, secondo la tabella seguente.

(F76)

PAINTING	Colore	Catalogazione RAL
<b>RAL7042</b>	Grigio traffico A	7042
<b>RAL5010</b>	Blu genziana	5010
<b>RAL9005</b>	Nero intenso	9005
<b>RAL9006</b>	Alluminio brillante	9006
<b>RAL9010</b>	Bianco puro	9010
<b>Munsell blue 8B* 4.5/3.25</b>	Blu	MUNSELL 8B 4.5/3.25
<b>RAL7035</b>	Grigio chiaro	7035
<b>RAL7001</b>	Grigio argento	7001
<b>RAL5015</b>	Blu cielo	5015
<b>RAL7037</b>	Grigio polvere	7037
<b>RAL5024</b>	Blu pastello	5024

\* I motori BX  $\geq$  200 e BX  $\geq$  200K sono forniti di serie in questo colore con protezione C3 se non diversamente specificato.

NOTA - L'opzione "VERNICIATURA" è configurabile esclusivamente in abbinamento con l'opzione "PROTEZIONE SUPERFICIALE".

## M12.24 Prove documentali

### ACM

#### Attestato di conformità motori

Documento il cui rilascio attesta la conformità del prodotto all'ordinativo e la costruzione dello stesso in conformità alle procedure standard di processo e di controllo previste dal sistema di Qualità Bonfiglioli Riduttori.

Nota: Non disponibile per BX $\geq$ 200 e BX $\geq$ 200K

### CC

#### Certificato di collaudo

La specifica comporta la conduzione di verifiche di conformità all'ordine, controlli visivi generali e verifiche strumentali delle caratteristiche elettriche di funzionamento a vuoto. Il collaudo è riferito allo specifico motore analizzato ed applicato ad un campione statistico del lotto di spedizione.



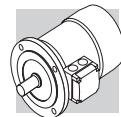





## M13 TABELLE DI CORRELAZIONE MOTORI

### M13.1 Motori a 50 Hz

(F77)

2 poli							
Classe di efficienza		IE1	IE2	IE3	IE1	IE2	IE3
Pn [kW]	0.06						
	0.09						
	0.12						
	0.18	BN 63A 2				M 05A 2	
	0.25	BN 63B 2				M 05B 2	
	0.37	BN 71A 2				M 05C 2	
	0.55	BN 71B 2				M 1SD 2	
	0.75	BN 71C 2 BN 80A 2	BE 80A 2			M 1LA 2	ME 2SA 2
	1.1	BN 80B 2	BE 80B 2			M 2SA 2	ME 2SB 2
	1.5	BN 90SA 2	BE 90SA 2			M 2SB 2	
	1.85	BN 90SB 2					
	2.2	BN 90L 2	BE 90L 2			M 3SA 2	
	3	BN 100L 2	BE 100L 2			M 3LA 2	ME 3LB 2
	4	BN 112M 2	BE 112M 2			M 3LB 2	
	5.5	BN 132SA 2	BE 132SA 2			M 4SA 2	ME 4SA 2
	7.5	BN 132SB 2	BE 132SB 2			M 4SB 2	ME 4LA 2
	9.2	BN 132M 2	BE 132MB 2			M 4LA 2	ME 4LB 2
	11	BN 160MR 2 BN 160M 2	BE 160MA 2			M 4LC 2	ME 5SA 2
	15	BN 160MB 2	BE 160MB 2			M 5SB 2	ME 5SB 2
18.5	BN 160L 2	BE 160L 2			M 5SC 2	ME 5LA 2	
22	BN 180M 2				M 5LA 2		
30	BN 200LA 2						



(F78)

4 poli									
Classe di efficienza		IE1	IE2	IE3	IE1	IE2	IE3		
Pn [kW]	0.06	BN 56A 4							
	0.09	BN 56B 4				M 0B 4			
	0.12	BN 63A 4	BE 63A 4		BXN 63MA 4	M 05A 4	ME 05A 4		MXN 05MA 4
	0.18	BN 63B 4	BE 63B 4		BXN 63MB 4	M 05B 4	ME 05B 4		MXN 05MB 4
	0.25	BN 63C 4				M 05C 4			
	0.37	BN 71A 4	BE 71A 4		BXN 71MA 4		ME 1SA 4		MXN 10MA 4
	0.37	BN 71B 4	BE 71B 4		BXN 71MB 4	M 1SD 4	ME 1SB 4		MXN 10MB 4
	0.55	BN 71C 4							
	0.55	BN 80A 4	BE 80A 4		BXN 80MA 4	M 1LA 4			MXN 20MA 4
	0.75	BN 80B 4	BE 80B 4	BX 80B 4	BXN 80MB 4	M 2SA 4	ME 2SB 4	MX 2SB 4	MXN 20MB 4
	1.1	BN 80C 4 BN 90S 4	BE 90S 4	BX 90S 4	BXN 90S 4	M 2SB 4	ME 3SA 4	MX 3SA 4	
	1.5	BN 90LA 4	BE 90LA 4	BX 90LA 4	BXN 90L 4	M 3SA 4	ME 3SB 4	MX 3SB 4	
	1.85	BN 90LB 4							
	2.2	BN 100LA 4	BE 100LA 4	BX 100LA 4		M 3LA 4	ME 3LA 4	MX 3LA 4	
	3	BN 100LB 4	BE 100LB 4	BX 100LB 4		M 3LB 4	ME 3LB 4	MX 3LB 4	
	4	BN 112M 4	BE 112M 4	BX 112M 4		M 3LC 4	ME 4SA 4	MX 4SA 4	
	5.5	BN 132S 4	BE 132S 4	BX 132SB 4		M 4SA 4	ME 4SB 4	MX 4SB 4	
	7.5	BN 132MA 4	BE 132MA 4	BX 132MA 4		M 4LA 4	ME 4LA 4	MX 4LA 4	
	9.2	BN 132MB 4	BE 132MB 4	BX 160MA 4		M 4LB 4	ME 4LB 4	MX 5SA 4	
	11	BN 160MR 4 BN 160M 4	BE 160M 4	BX 160MB 4		M 4LC 4	ME 5SA 4	MX 5SB 4	
	15	BN 160L 4	BE 160L 4	BX 160L 4		M 5SB 4	ME 5LA 4	MX 5LA 4	
	18.5	BN 180M 4	BE 180M 4	BX 180M 4		M 5LA 4			
	22	BN 180L 4	BE 180L 4	BX 180L 4					
	30	BN 200L 4		BX 200LA 4*					
	37			BX 225SA 4*					
	45			BX 225SB 4*					
	55			BX 250MA 4*					
	75			BX 280SA 4*					
	90			BX 280SB 4*					
	110			BX 315SA 4*					
132			BX 315SB 4*						
160			BX 315SC 4*						
200			BX 315MA 4*						
250			BX 355MA 4*						
315			BX 355MB 4*						
355			BX 355MC 4*						

Nota: per il mercato australiano questi motori devono essere selezionati nella versione BX ... K 4





(F79)

6 poli							
Classe di efficienza		IE1	IE2	IE3	IE1	IE2	IE3
Pn [kW]	0.06						
	0.09	BN 63A 6			M 05A 6		
	0.12	BN 63B 6			M 05B 6		
	0.18	BN 71A 6			M 1SC 6		
	0.25	BN 71B 6			M 1SD 6		
		BN 71C 6					
	0.37	BN 80A 6			M 1LA 6		
	0.55	BN 80B 6			M 2SA 6		
	0.75	BN 80C 6	BE 90S 6		M 2SB 6		
		BN 90S 6					
	1.1	BN 90L 6	BE 100M 6		M 3SA 6	ME 3LA 6	
	1.5	BN 100LA 6	BE 100LA 6		M 3LA 6	ME 3LB 6	
	1.85	BN 100LB 6			M 3LB 6		
	2.2	BN 112M 6	BE 112M 6		M 3LC 6		
	3	BN 132S 6	BE 132S 6		M 4SA 6	ME 4SB 6	
	4	BN 132MA 6	BE 132MA 6		M 4LA 6	ME 4LA 6	
	5.5	BN 132MB 6	BE 160MA 6		M 4LB 6	ME 5SA 6	
	7.5	BN 160M 6	BE 160MB 6		M 5SA 6	ME 5SB 6	
	9.2						
	11	BN 160L 6			M 5SB 6		
15	BN 180L 6						
18.5	BN 200LA 6						
22							
30							



### M13.2 Motori a 60 Hz

(F80)



2 poli							
Classe di efficienza		IE1	IE2	IE3	IE1	IE2	IE3
Pn [kW]	0.06						
	0.09						
	0.12						
	0.18	BN 63A 2			M 05A 2		
	0.25	BN 63B 2			M 05B 2		
	0.37	BN 71A 2			M 05C 2		
	0.55	BN 71B 2			M 1SD 2		
		BN 71C 2					
	1.1	BN 80A 2			M 1LA 2		
		BN 80B 2					
	1.5	BN 90SA 2			M 2SA 2		
	1.85	BN 90SB 2			M 2SB 2		
	2.2	BN 90L 2			M 3SA 2		
	3	BN 100L 2			M 3LA 2		
	3.7	BN 112M 2			M 3LB 2		
	5.5	BN 132SA 2			M 4SA 2		
	7.5	BN 132SB 2			M 4SB 2		
	9.2	BN 132M 2			M 4LA 2		
	11	BN 160MR 2			M 4LC 2		
		BN 160M 2					
15	BN 160MB 2			M 5SB 2			
18.5	BN 160L 2			M 5SC 2			
22	BN 180M 2			M 5LA 2			
30	BN 200LA 2						







(F81)

4 poli								
Classe di efficienza	IE1	IE2	IE3		IE1	IE2	IE3	
Pn [kW]	0.06	BN 56A 4						
	0.09	BN 56B 4			M 0B 4			
	0.12	BN 63A 4	BE 63A 4		BXN 63MA 4	M 05A 4	MXN 05MA 4	
	0.18	BN 63B 4	BE 63B 4		BXN 63MB 4	M 05B 4		MXN 05MB 4
		BN 63C 4						
	0.25	BN 71A 4	BE 71A 4		BXN 71MA 4	M 05C 4		MXN 10MA 4
		BN 71B 4	BE 71B 4		BXN 71MB 4	M 1SD 4		MXN 10MB 4
	0.55	BN 71C 4				M 1LA 4		
		BN 80A 4	BE 80A 4		BXN 80MA 4			MXN 20MA 4
	0.75	BN 80B 4	BE 80B 4	BX 90SR 4	BXN 80MB 4	M 2SA 4	ME 2SB 4	MX 2SB 4
		BN 80C 4						
	1.1	BN 90S 4	BE 90S 4	BX 90S 4	BXN 90S 4	M 2SB 4	ME 3SA 4	MX 3SA 4
		BN 90LA 4	BE 90LA 4	BX 90LA 4	BXN 90L 4	M 3SA 4	ME 3SB 4	MX 3SB 4
	1.85	BN 90LB 4						
	2.2	BN 100LA 4	BE 100LA 4	BX 100LA 4		M 3LA 4	ME 3LA 4	MX 3LA 4
	3	BN 100LB 4	BE 100LB 4	BX 100LB 4		M 3LB 4	ME 3LB 4	MX 3LB 4
	3.7	BN 112M 4	BE 112M 4	BX 112M 4		M 3LC 4	ME 4SA 4	MX 4SA 4
	5.5	BN 132S 4	BE 132S 4	BX 132SB 4		M 4SA 4	ME 4SB 4	MX 4SB 4
	7.5	BN 132MA 4	BE 132MA 4	BX 132MA 4		M 4LA 4	ME 4LA 4	MX 4LA 4
		BN 132MB 4	BE 132MB 4	BX 160MA 4		M 4LB 4	ME 4LB 4	MX 5SA 4
	11	BN 160MR 4						
		BN 160M 4	BE 160M 4	BX 160MB 4		M 4LC 4	ME 5SA 4	MX 5SB 4
	15	BN 160L 4	BE 160L 4	BX 160L 4		M 5SB 4	ME 5LA 4	MX 5LA 4
	18.5	BN 180M 4	BE 180M 4	BX 180M 4		M 5LA 4		
	22	BN 180L 4	BE 180L 4	BX 180L 4				
	30	BN 200L 4		BX 200LAK 4				
	37			BX 225SAK 4				
	45			BX 225SBK 4				
	55			BX 280SAK 4				
	75			BX 280SBK 4				
90			BX 315SAK 4					
110			BX 315SBK 4					
132			BX 315SCK 4					
160			BX 355SAK 4					
200			BX 355SBK 4					
250			BX 355SCK 4					
315			BX 355MBK 4					
355			BX 355MCK 4					

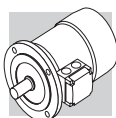
(F82)







6 poli							
Classe di efficienza	IE1	IE2	IE3	IE1	IE2	IE3	
Pn [kW]	0.06						
	0.09	BN 63A 6			M 05A 6		
	0.12	BN 63B 6			M 05B 6		
	0.18	BN 71A 6			M 1SC 6		
		BN 71B 6					
	0.25	BN 71C 6			M 1SD 6		
		BN 80A 6			M 1LA 6		
	0.37	BN 80A 6			M 1LA 6		
	0.55	BN 80B 6			M 2SA 6		
	0.75	BN 80C 6					
		BN 90S 6			M 2SB 6		
	1.1	BN 90L 6			M 3SA 6		
	1.5	BN 100LA 6			M 3LA 6		
	1.85	BN 100LB 6			M 3LB 6		
	2.2	BN 112M 6			M 3LC 6		
	3	BN 132S 6			M 4SA 6		
	3.7	BN 132MA 6			M 4LA 6		
	5.5	BN 132MB 6			M 4LB 6		
	7.5	BN 160M 6			M 5SA 6		
	9.2						
11	BN 160L 6			M 5SB 6			
15	BN 180L 6						
18.5	BN 200LA 6						
22							
30							

**M14 DATI TECNICI MOTORI BXN-MXN**

<b>4 P</b>		<b>1500 min<sup>-1</sup> - S1</b>											<b>50 Hz - IE3</b>											
<b>P<sub>n</sub></b> kW		<b>n</b> min <sup>-1</sup>	<b>M<sub>n</sub></b> Nm	<b>I<sub>n</sub></b> 400V A	<b>η%</b>		<b>cos φ</b>	<b>I<sub>s</sub></b> I <sub>n</sub>	<b>M<sub>s</sub></b> M <sub>n</sub>	<b>M<sub>s</sub></b> M <sub>n</sub>	<b>KVA</b> code	<b>J<sub>m</sub></b> x 10 <sup>-4</sup> kgm <sup>2</sup>	<b>IM B5</b> 	<b>freno c.c.</b>				<b>freno c.a.</b>						
					100%	75%								<b>M<sub>b</sub></b> Nm	<b>Z<sub>o</sub></b> 1/h	<b>SB</b>	<b>J<sub>m</sub></b> x 10 <sup>-4</sup> kgm <sup>2</sup>	<b>IM B5</b> 	<b>Mod</b>	<b>M<sub>b</sub></b> Nm	<b>Z<sub>o</sub></b> 1/h	<b>J<sub>m</sub></b> x 10 <sup>-4</sup> kgm <sup>2</sup>	<b>IM B5</b> 	
					50%	50%																		<b>FD</b>
0.12	<b>BXN 63MA 4</b>	1407	0.8	0.47	64.8	60.3	0.58	3.4	2.9	1.7	H	1.82	4.6	<b>FD 02</b>	1.8	8900	11000	2.4	6.3	<b>FA 02</b>	1.8	11000	2.4	6.1
0.18	<b>BXN 63MB 4</b>	1373	1.3	0.61	69.9	68.8	0.61	3.5	3.1	1.8	G	2.92	5.7	<b>FD 02</b>	3.5	7000	9000	3.5	7.4	<b>FA 02</b>	3.5	9000	3.5	7.2
0.25	<b>BXN 71MA 4</b>	1388	1.7	0.67	73.5	72.8	0.74	4.8	1.6	2.4	H	6.28	6.5	<b>FD 53</b>	5	5700	8100	7.4	9.2	<b>FA 03</b>	5	8100	7.4	8.9
0.37	<b>BXN 71MB 4</b>	1429	2.5	1.05	77.3	76.0	0.66	6.3	2.6	2.5	L	9.70	8.3	<b>FD 53</b>	5	6400	9900	10.8	11.0	<b>FA 03</b>	5	9900	10.8	10.7
0.55	<b>BXN 80MA 4</b>	1447	3.6	1.31	80.8	80.9	0.75	6.1	1.9	1.6	J	17.78	10.7	<b>FD 04</b>	10	2500	5200	19.8	14.6	<b>FA 04</b>	10	5200	19.8	14.5
0.75	<b>BXN 80MB 4</b>	1451	4.9	1.63	82.5	85.1	0.78	7.4	2.4	2.0	K	28.89	14.4	<b>FD 04</b>	15	2000	4100	30.8	18.3	<b>FA 04</b>	15	4100	30.8	18.2
1.1	<b>BXN 90S 4</b>	1448	7.3	2.38	84.1	85.9	0.78	7.3	2.4	3.4	J	31.76	15.6	<b>FD 05</b>	26	2800	6600	35.8	21.6	<b>FA 05</b>	26	6600	35.8	22.3
1.5	<b>BXN 90L 4</b>	1441	9.9	3.44	85.3	84.3	0.75	6.7	2.6	2.4	J	34.96	16.6	<b>FD 05</b>	26	1400	3100	39.1	22.6	<b>FA 05</b>	26	3100	39.1	23.3

Nota: per maggiori dettagli sulle certificazioni energetiche disponibili consulta la sezione dedicata del catalogo.



4 P		1500 min <sup>-1</sup> - S1											50 Hz - IE3											
		freno c.c.											freno c.a.											
		FD											FA											
		Mod	M <sub>b</sub>	Z <sub>0</sub> 1/h	J <sub>m</sub> x 10 <sup>-4</sup> kgm <sup>2</sup>	IM B5 	Mod	M <sub>b</sub>	Z <sub>0</sub> 1/h	J <sub>m</sub> x 10 <sup>-4</sup> kgm <sup>2</sup>	IM B5 	Mod	M <sub>b</sub>	Z <sub>0</sub> 1/h	J <sub>m</sub> x 10 <sup>-4</sup> kgm <sup>2</sup>	IM B5 								
P <sub>n</sub>	kW	n	M <sub>n</sub>	In 400V	η%	cos φ	I <sub>s</sub> I <sub>n</sub>	M <sub>s</sub> M <sub>n</sub>	M <sub>a</sub> M <sub>n</sub>	KVA code	J <sub>m</sub> x 10 <sup>-4</sup> kgm <sup>2</sup>	IM B5 	Mod	M <sub>b</sub>	NB	SB	Z <sub>0</sub> 1/h	J <sub>m</sub> x 10 <sup>-4</sup> kgm <sup>2</sup>	IM B5 	Mod	M <sub>b</sub>	Z <sub>0</sub> 1/h	J <sub>m</sub> x 10 <sup>-4</sup> kgm <sup>2</sup>	IM B5 
0.12		1407	0.8	0.47	60.3	0.58	3.4	2.9	1.7	H	1.82	4.6	FD 02	1.8	8900	11000	2.4	6.3	FA 02	1.8	11000	2.4	6.1	
0.18		1373	1.3	0.61	68.8	0.61	3.5	3.1	1.8	G	2.92	5.7	FD 02	3.5	7000	9000	3.5	7.4	FA 02	3.5	9000	3.5	7.2	
0.25		1388	1.7	0.67	73.5	0.74	4.8	1.6	2.4	H	6.28	6.5	FD 53	5	5700	8100	7.4	9.2	FA 03	5	8100	7.4	8.9	
0.37		1429	2.5	1.05	77.3	0.66	6.3	2.6	2.5	L	9.70	8.3	FD 53	5	6400	9900	10.8	11.0	FA 03	5	9900	10.8	10.7	
0.55		1447	3.6	1.31	80.8	0.75	6.1	1.9	1.6	J	17.78	10.7	FD 04	10	2500	5200	19.8	14.6	FA 04	10	5200	19.8	14.5	
0.75		1451	4.9	1.63	82.5	0.78	7.4	2.4	2.0	K	28.89	14.4	FD 04	15	2000	4100	30.8	18.3	FA 04	15	4100	30.8	18.2	

Nota: per maggiori dettagli sulle certificazioni energetiche disponibili consulta la sezione dedicata del catalogo.

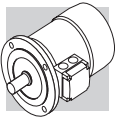

**BXN - IM B5 - CE CUS/UKCA**

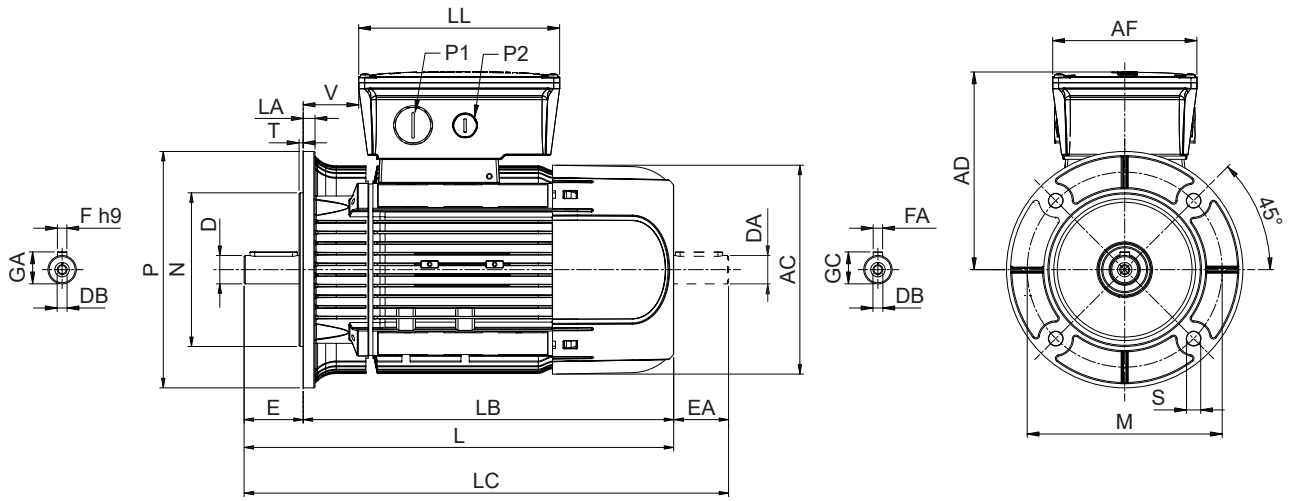

	Albero					Flangia						Motore									
	D DA	E EA	DB	GA GC	F FA	M	N	P	S	T	LA	AC	L	LB	LC	AD	AF	LL	V		
<b>BXN 63</b>	11 9 <sup>(1)</sup>	23 20 <sup>(1)</sup>	M4 M3 <sup>(1)</sup>	12.5 10.2 <sup>(1)</sup>	4 3 <sup>(1)</sup>	115	95	140	9.5	3	9	122	281	258	301	136	112	165	37		
<b>BXN 71</b>	14 11 <sup>(1)</sup>	30 23 <sup>(1)</sup>	M5 M4 <sup>(1)</sup>	16 12.5 <sup>(1)</sup>	5 4 <sup>(1)</sup>	130	110	160				158	292	262	315	138				40	
<b>BXN 80</b>	19 14 <sup>(1)</sup>	40 30 <sup>(1)</sup>	M6 M5 <sup>(1)</sup>	21.5 16 <sup>(1)</sup>	6 5 <sup>(1)</sup>	165	130	200	11.5	3.5	10	177	365	315	405	170				170	43
<b>BXN 90</b>	24 19 <sup>(1)</sup>	50 40 <sup>(1)</sup>	M8 M6 <sup>(1)</sup>	27 21.5 <sup>(1)</sup>	8 6 <sup>(1)</sup>							177	365	315	405	170					

N.B.: 1) Queste dimensioni sono riferite alla seconda estremità d'albero (PS).





**BXN - IM B5 - FD/FA - CE - CUS/UKCA**

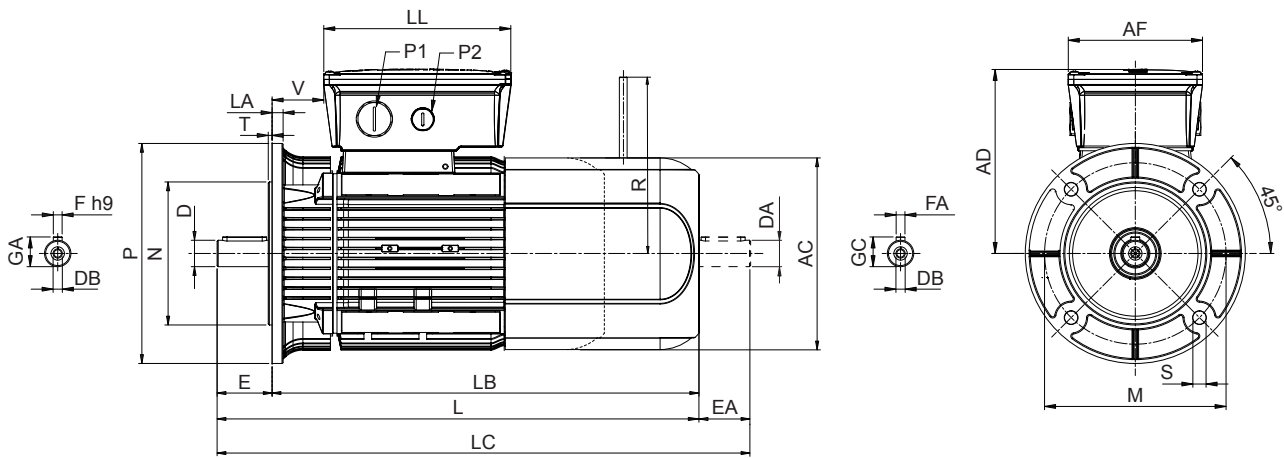

	Albero					Flangia						Motore									
	D	E	DB	GA	F	M	N	P	S	T	LA	AC	L	LB	LC	AD	AF	LL	V	R	
	DA	EA		GC	FA															FD	FA
<b>BXN 63</b>	11 9 <sup>(1)</sup>	23 20 <sup>(1)</sup>	M4 M3 <sup>(1)</sup>	12.5 10.2 <sup>(1)</sup>	4 3 <sup>(1)</sup>	115	95	140	9.5	3	9	122	328	305	352	136	112	165	37	96	116
<b>BXN 71</b>	14 11 <sup>(1)</sup>	30 23 <sup>(1)</sup>	M5 M4 <sup>(1)</sup>	16 12.5 <sup>(1)</sup>	5 4 <sup>(1)</sup>	130	110	160		9.5		3	9	138	351	321			380	138	34
<b>BXN 80</b>	19 14 <sup>(1)</sup>	40 30 <sup>(1)</sup>	M6 M5 <sup>1)</sup>	21.5 16 <sup>(1)</sup>	6 5 <sup>(1)</sup>	165	130	200	11.5	3.5	10	158	417	377	448	148			40	129	131
<b>BXN 90</b>	24 19 <sup>(1)</sup>	50 40 <sup>(1)</sup>	M8 M6 <sup>(1)</sup>	27 21.5 <sup>(1)</sup>	8 6 <sup>(1)</sup>							177	433	383	451	170			170	43	160

N.B.: 1) Queste dimensioni sono riferite alla seconda estremità d'albero (PS).





**BXN - IM B14 - FD/FA - CE - CUS/UKCA**

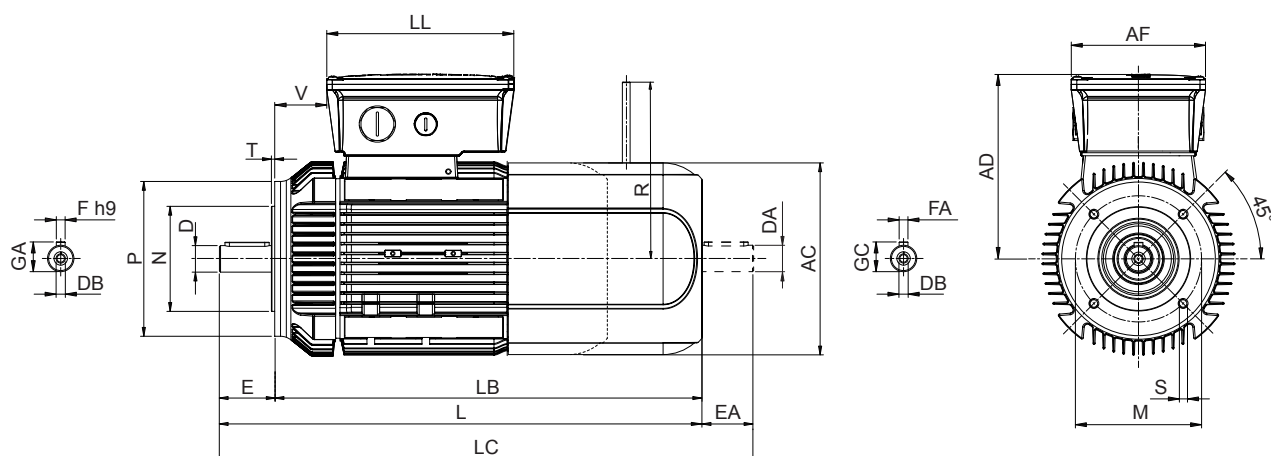

	Albero					Flangia					Motore									
	D	E	DB	GA	F	M	N	P	S	T	AC	L	LB	LC	AD	AF	LL	V	R	
	DA	EA		GC	FA														FD	FA
<b>BXN 63</b>	11 9 <sup>(1)</sup>	23 20 <sup>(1)</sup>	M4 M3 <sup>(1)</sup>	12.5 10.2 <sup>(1)</sup>	4 3 <sup>(1)</sup>	75	60	90	M5	2.5	122	328	305	352	136	112	165	37	96	116
<b>BXN 71</b>	14 11 <sup>(1)</sup>	30 23 <sup>(1)</sup>	M5 M4 <sup>(1)</sup>	16 12.5 <sup>(1)</sup>	5 4 <sup>(1)</sup>	85	70	105	M6		138	351	321	380	138			34	103	121
<b>BXN 80</b>	19 14 <sup>(1)</sup>	40 30 <sup>(1)</sup>	M6 M5 <sup>(1)</sup>	21.5 16 <sup>(1)</sup>	6 5 <sup>(1)</sup>	100	80	120	M8	3	158	417	377	448	148		40	129	131	
<b>BXN 90</b>	24 19 <sup>(1)</sup>	50 40 <sup>(1)</sup>	M8 M6 <sup>(1)</sup>	27 21.5 <sup>(1)</sup>	8 6 <sup>(1)</sup>	115	95	140			177	433	383	451	170		170	43	160	160

N.B.: 1) Queste dimensioni sono riferite alla seconda estremità d'albero (PS).



**MXN**

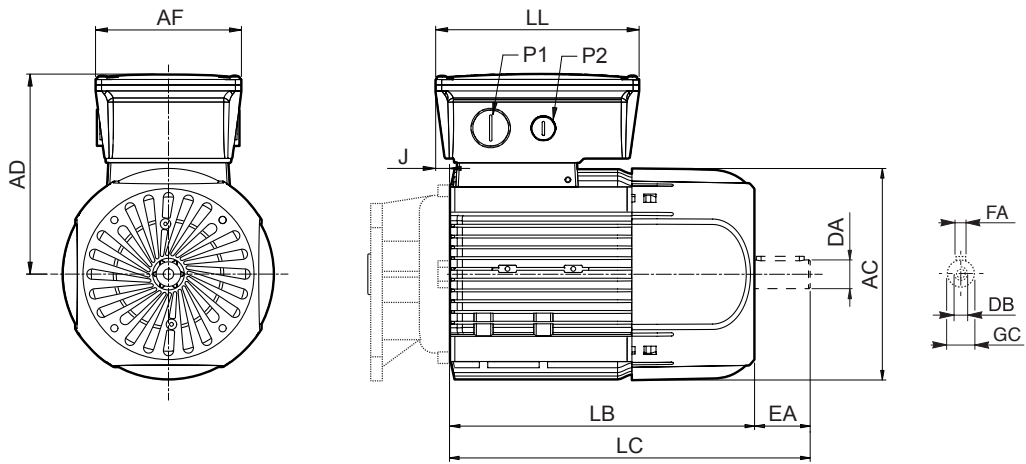

	Seconda estremità albero					Motore						
	DA	EA	DB	FA	GC	AC	LB	LC	AF	LL	J	AD
<b>MXN 05</b>	9	20	M3	3	10.2	123	211.5	231.5	112	165	9.5	136
<b>MXN 10</b>	11	23	M4	4	12.5	138	216	239	112	165	11.5	137
<b>MXN 20</b>	14	30	M5	5	16	158	255.5	285.5	112	165	10.5	146



**MXN\_FD/FA**

**BXN-MXN**

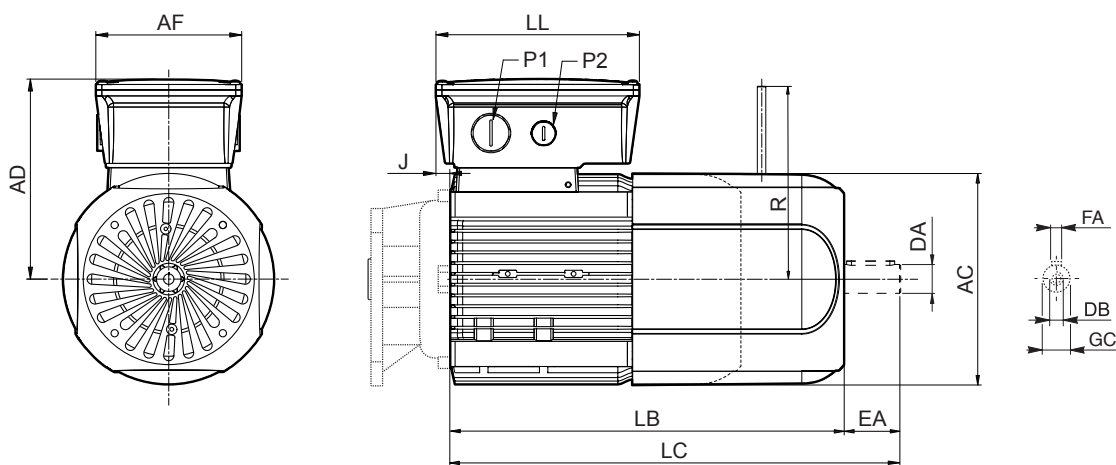

	Seconda estremità albero					Motore								
	DA	EA	DB	FA	GC	AC	LB	LC	AF	LL	J	AD	R	
													FD	FA
<b>MXN 05</b>	9	20	M3	3	10.2	122	211.5	258.5	112	165	9.5	136	96	116
<b>MXN 10</b>	11	23	M4	4	12.5	138	216	275	112	165	11.5	138	103	121
<b>MXN 20</b>	14	30	M5	5	16	158	255.5	326.5	112	165	10.5	148	129	131

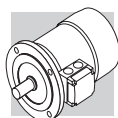

## M16 DATI TECNICI MOTORI BX-MX

4 P		1500 min <sup>-1</sup> - S1											50 Hz - IE3								
P <sub>n</sub> kW		n min <sup>-1</sup>	M <sub>n</sub> Nm	I <sub>n</sub> 400V A	η <sub>1</sub> %			cos φ	$\frac{I_s}{I_h}$	$\frac{M_s}{M_n}$	$\frac{M_a}{M_n}$	KVA code	J <sub>m</sub> x 10 <sup>-4</sup> kgm <sup>2</sup>	IM B5 	freno c.c.			freno c.a.			
					100%	75%	50%								FD			FA			
					M <sub>b</sub> Nm	J <sub>m</sub> x 10 <sup>-4</sup> kgm <sup>2</sup>	IM B5 								M <sub>b</sub> Nm	J <sub>m</sub> x 10 <sup>-4</sup> kgm <sup>2</sup>	IM B5 	M <sub>b</sub> Nm	J <sub>m</sub> x 10 <sup>-4</sup> kgm <sup>2</sup>	IM B5 	
0.75	<b>BX 80B</b>	4	1425	5.0	1.61	82.5	83.9	83.2	0.81	6.5	2.0	1.8	J	35	16	19.9	15	37	19.8	15	37
1.1	<b>BX 90S</b>	4	1425	7.4	2.44	84.1	84.1	82.0	0.77	6.9	3.4	2.2	J	27	16	20.2	15	29	20.1	15	29
1.5	<b>BX 90LA</b>	4	1420	10.1	3.3	85.3	86.2	84.9	0.78	6.3	3.1	1.9	J	31	17	23	26	35	23.7	26	35
2.2	<b>BX 100LA</b>	4	1445	14.5	5.1	86.7	86.2	84.0	0.72	7.2	3.6	2.4	K	58	24	31	40	62	31	40	62
3	<b>BX 100LB</b>	4	1445	19.8	6.7	87.7	87.7	86.0	0.74	7.6	3.9	2.6	K	73	29	36	40	77	36	40	77
4	<b>BX 112M</b>	4	1445	26	8.1	88.6	88.9	87.6	0.8	8.1	3.8	2.5	J	130	38	48	60	139	50	60	139
5.5	<b>BX 132SB</b>	4	1460	36	10.6	89.6	89.2	88.8	0.83	8.2	3.6	2.3	J	310	57	70	75	320	71	75	320
7.5	<b>BX 132MA</b>	4	1460	49	15.0	90.4	90.9	90.2	0.80	8.4	3.8	2.5	K	360	67	80	100	370	85	100	370
9.2	<b>BX 160MA</b>	4	1465	60	17.8	91.0	92.1	91.7	0.82	7.9	3.6	2.1	J	650	95	125	170	725	124	170	725
11	<b>BX 160MB</b>	4	1465	72	20.5	91.4	92.9	92.5	0.84	7.8	3.4	1.9	J	780	110	140	170	855	139	170	855
15	<b>BX 160L</b>	4	1465	98	28.1	92.1	93.2	92.6	0.82	9.0	4.1	2.3	K	890	121	151	200	965	150	200	965
18.5	<b>BX 180M</b>	4	1480	119	32.9	92.6	94.1	93.1	0.85	11.3	2.6	2.3	M	1560	155	195	300	1760	195	300	1760
22	<b>BX 180L</b>	4	1475	142	38.2	93.0	93.6	92.8	0.88	10.2	2.5	2.0	L	1660	163	203	300	1860	203	300	1860



Nota: per maggiori dettagli sulle certificazioni energetiche disponibili, consultare la sezione dedicata del catalogo.

<b>4 P</b>	<b>1500 min<sup>-1</sup> - S1</b>	<b>50 Hz - IE3</b>
------------	-----------------------------------	--------------------

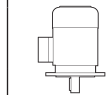

P <sub>n</sub> kW	n min <sup>-1</sup>	M <sub>n</sub> Nm	I <sub>n</sub> 400V A	η%		cos φ	I <sub>s</sub> I <sub>n</sub>	M <sub>s</sub> M <sub>n</sub>	M <sub>a</sub> M <sub>n</sub>	KVA code	J <sub>m</sub> x 10 <sup>-4</sup> kgm <sup>2</sup>	IM B5 Kg	freno c.c.			freno c.a.				
				100%	75%								50%	FD			FA			
													M <sub>b</sub> Nm	J <sub>m</sub> x 10 <sup>-4</sup> kgm <sup>2</sup>	IM B5 Kg	Mod	M <sub>b</sub> Nm	J <sub>m</sub> x 10 <sup>-4</sup> kgm <sup>2</sup>	IM B5 Kg	
30	<b>BX 200LA 4</b>	193.2	54.8	93.6	93.9	0.84	7.5	2.7	3.2	N/A	3850	292	260	3910	317					
37	<b>BX 225SA 4</b>	238.6	68.9	93.9	94.1	0.83	7.2	3.1	3.1	N/A	4270	322	400	4450	356					
45	<b>BX 225SB 4</b>	290	82.3	94.2	94.4	0.84	8	3.2	3.5	N/A	5250	357	400	5430	391					
55	<b>BX 250MA 4</b>	354.2	100	94.6	94.7	0.84	7.1	2.9	3.4	N/A	6940	406	1000	7540	452					
75	<b>BX 280SA 4</b>	483	133	95	95.2	0.86	6.4	2.3	2.8	N/A	13800	645	1000	14400	691					
90	<b>BX 280SB 4</b>	578	158	95.2	95.5	0.86	7.1	2.5	2.9	N/A	17300	700	1000	17900	746					
110	<b>BX 315SA 4</b>	705	198	95.4	95.5	0.84	7	2.1	3	N/A	24300	930	1000	24900	976					
132	<b>BX 315SB 4</b>	847	231	95.6	95.9	0.86	6.7	2.2	2.9	N/A	29000	1000	1600	30500	1121					
160	<b>BX 315SC 4</b>	1026	282	95.8	96	0.85	6.9	2.2	3	N/A	32000	1065	1600	33500	1186					
200	<b>BX 315MA 4</b>	1284	351	96	96.4	0.86	6.8	2.4	3	N/A	39000	1220	2500	41400	1390					
250	<b>BX 355MA 4</b>	1601	435	96	96	0.86	6.4	2.1	2.9	N/A	59000	1610	2500	61400	1780					
315	<b>BX 355MB 4</b>	2018	550	96	96.1	0.85	7.3	2.4	3.3	N/A	69000	1780	4000	73300	2000					
355	<b>BX 355MC 4</b>	2273	616	96	96.2	0.86	6.3	2.3	2.8	N/A	72000	1820	4000	76300	2040					



Nota: per maggiori dettagli sulle certificazioni energetiche disponibili, consultare la sezione dedicata del catalogo.

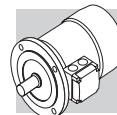

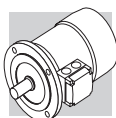





4 P		1500 min <sup>-1</sup> - S1												50 Hz - IE3						
P <sub>n</sub> kW	EECA	n min <sup>-1</sup>	M <sub>n</sub> Nm	I <sub>n</sub> 400V A	η%		cos φ	I <sub>s</sub> I <sub>n</sub>	M <sub>s</sub> M <sub>n</sub>	M <sub>a</sub> M <sub>n</sub>	KVA code	J <sub>m</sub> x 10 <sup>-4</sup> kgm <sup>2</sup>	IM B5 Kg	freno c.c.			freno c.a.			
					100%	75%								50%	FD			FA		
					M <sub>b</sub> Nm	J <sub>m</sub> x 10 <sup>-4</sup> kgm <sup>2</sup>								IM B5 Kg	Mod	M <sub>b</sub> Nm	J <sub>m</sub> x 10 <sup>-4</sup> kgm <sup>2</sup>	IM B5 Kg	Mod	M <sub>b</sub> Nm
30		<b>BX 200LAK 4</b>	1483	193	55.7	94.7	95.1	0.82	8.3	3	N/A	3660	319	FD 8	400	3940	337			
37		<b>BX 225SAK 4</b>	1482	238	65.9	95.1	95.5	0.85	7.7	2.8	N/A	5360	398	FD 9	600	5720	426			
45		<b>BX 225SBK 4</b>	1481	290	80.4	95.2	95.6	0.85	7.9	2.8	N/A	5360	398	FD 9	600	5720	426			
55		<b>BX 250MAK 4</b>	1485	354	98.9	95.6	95.8	0.84	7.9	3	N/A	9330	476	FD 10	800	10080	521			
75		<b>BX 280SAK 4</b>	1487	482	134	95.9	96.2	0.84	7.3	2.5	N/A	15000	665	FD 1000	1000	15360	771			
90		<b>BX 280SBK 4</b>	1487	578	161	96.2	96.4	0.84	7.9	2.9	N/A	18500	725	FD 1000	1000	18860	831			
110		<b>BX 315SAK 4</b>	1491	704	194	96.8	97	0.84	8.3	2.4	N/A	29000	1000	FD 1000	1000	29360	1106			
132		<b>BX 315SBK 4</b>	1490	846	234	96.9	97.1	0.84	8.1	2.6	N/A	32000	1065	FD 1600	1600	32500	1233			
160		<b>BX 315SCK 4</b>	1490	1025	279	96.7	96.9	0.86	8.2	2.7	N/A	39000	1220	FD 1600	1600	39500	1388			
200		<b>BX 355SAK 4</b>	1491	1281	345	96.6	96.7	0.87	7.3	2.1	N/A	59000	1610	FD 2500	2500	59500	1778			
250		<b>BX 355MAK 4</b>	1491	1601	435	96	96	0.86	6.4	2.1	N/A	69000	1780	FD 2500	2500	69500	1948			
315		<b>BX 355MBK 4</b>	1491	2017	550	96	96.1	0.85	7.3	2.4	N/A	72000	1820	FD 2500	2500	72500	1988			
355		<b>BX 355MCK 4</b>	1490	2275	616	96	96.2	0.86	6.3	2.3	N/A	84000	2140	FD 2500	2500	84500	2308			

Nota: per maggiori dettagli sulle certificazioni energetiche disponibili, consultare la sezione dedicata del catalogo.



4 P		1800 min <sup>-1</sup> - S1												60 Hz - Nema Premium								
P <sub>n</sub> kW	ENERGY <b>EU</b> US	 <small>REGOLAMENTO EUROPEO DI EFFICIENZA PRIMA FORMA DI EFFICIENZA PROCEL NBR - 17094-1</small>	n min <sup>-1</sup>	M <sub>n</sub> Nm	I <sub>n</sub> 460V A	η%		cos φ	I <sub>s</sub> I <sub>n</sub>	M <sub>s</sub> M <sub>n</sub>	M <sub>a</sub> M <sub>n</sub>	KVA code	J <sub>m</sub> x 10 <sup>-4</sup> kgm <sup>2</sup>	IM B5 	freno c.c.							
						100%	75%								FD				FA			
						Mod	M <sub>b</sub> Nm								J <sub>m</sub> x 10 <sup>-4</sup> kgm <sup>2</sup>	IM B5 	Mod	M <sub>b</sub> Nm	J <sub>m</sub> x 10 <sup>-4</sup> kgm <sup>2</sup>	IM B5 		
0.75			1755	4.1	1.48	85.5	86.4	0.73	8.0	3.7	2.5	L	27	16	FD 14	15	29	20.2	FA 14	15	29	20.1
1.1			1740	6.0	2.15	86.5	85.9	0.74	8.2	4.1	2.8	K	27	16	FD 14	15	29	20.2	FA 14	15	29	20.1
1.5			1735	8.3	2.91	86.5	86.5	0.75	7.4	3.6	2.5	K	31	17	FD 05	26	35	23	FA 05	26	35	23.7
2.2			1760	11.9	4.4	89.5	88.6	0.71	9.9	4.8	3.6	N	73	29	FD 15	40	77	36	FA 15	40	77	36
3			1750	16.4	5.9	89.5	88.9	0.71	9.1	4.4	3.3	M	73	29	FD 15	40	77	36	FA 15	40	77	36
3.7			1760	20	6.7	89.5	89.5	0.77	10.4	4.7	3.4	M	130	38	FD 06S	60	139	48	FA 06S	60	139	50
5.5			1770	30	9.9	91.7	92.0	0.76	10.7	5.1	4.6	N	410	77	FD 56	75	420	90	FA 06	75	420	91
7.5			1770	41	13.4	91.7	91.3	0.76	11.0	4.9	4.4	N	410	77	FD 06	100	420	90	FA 07	100	420	95
9.2			1770	50	15.6	92.4	92.5	0.8	9.1	4.1	2.6	L	650	95	FD 08	170	725	125	FA 08	170	725	124
11			1770	59	18.2	92.4	92.9	0.82	9.3	4.0	2.4	L	780	110	FD 08	170	855	140	FA 08	170	855	139
15			1770	81	24.5	93.0	93.5	0.81	10.9	4.8	2.8	M	890	121	FD 08	200	965	151	FA 08	200	965	150
18.5			1780	99	28.6	93.6	94.5	0.85	13.0	2.9	2.7	N	1560	155	FD 09	300	1760	195				
22			1775	118	33.1	93.6	94.2	0.87	11.5	2.8	2.4	M	1660	163	FD 09	300	1860	203				

Nota: per maggiori dettagli sulle certificazioni energetiche disponibili, consultare la sezione dedicata del catalogo.

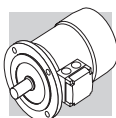





4 P		1800 min <sup>-1</sup> - S1										60 Hz - Nema Premium									
		freno c.c.										freno c.a.									
		FD										FA									
P <sub>n</sub>	kW		n	M <sub>n</sub>	In	η%	cos φ	$\frac{I_s}{I_h}$	$\frac{M_s}{M_h}$	$\frac{M_a}{M_h}$	KVA code	J <sub>m</sub> x 10 <sup>-4</sup>	IM B5	Mod	M <sub>b</sub>	J <sub>m</sub> x 10 <sup>-4</sup>	IM B5	Mod	M <sub>b</sub>	J <sub>m</sub> x 10 <sup>-4</sup>	IM B5
			min <sup>-1</sup>	Nm	A	100% 75% 50%						kgm <sup>2</sup>			Nm	kgm <sup>2</sup>			Nm	kgm <sup>2</sup>	
30	BX 200LAK 4	1786	160	47.9	94.7 94.8 94.1	0.83	9.4	3.3	3.7	N/A	3660	319	FD 8	400	3940	337					
37	BX 225SAK 4	1784	198	57.3	95.3 95.5 94.9	0.85	8.8	2.9	3.4	N/A	5360	398	FD 9	600	5720	426					
45	BX 225SBK 4	1785	240	70.5	95.3 95.4 94.8	0.84	8.9	3	3.6	N/A	5360	398	FD 9	600	5720	426					
55	BX 250MAK 4	1787	293	85.8	95.7 95.8 95.2	0.84	9.1	3.3	3.7	N/A	9330	476	FD 10	800	10080	521					
75	BX 280SAK 4	1788	401	117	95.9 95.7 94.7	0.84	8.4	2.7	3.1	N/A	15000	665	FD 1000	1000	15360	771					
90	BX 280SBK 4	1788	481	140	96.1 95.9 95	0.84	9	3.1	3.3	N/A	18500	725	FD 1000	1000	18860	831					
110	BX 315SAK 4	1792	586	172	96.1 96 95.3	0.84	8.8	2.6	3.4	N/A	29000	1000	FD 1000	1000	29360	1106					
132	BX 315SBK 4	1791	704	206	96.4 96.3 95.6	0.84	9	2.8	3.6	N/A	32000	1065	FD 1600	1600	32500	1233					
160	BX 315SCK 4	1791	853	241	96.4 96.4 95.9	0.86	9	2.9	3.3	N/A	39000	1220	FD 1600	1600	39500	1388					
200	BX 355SAK 4	1792	1065	301	96.4 96.2 95.4	0.87	8.3	2.2	3	N/A	59000	1610	FD 2500	2500	59500	1778					
250	BX 355MAK 4	1792	1332	381	96.7 96.6 96	0.86	8.8	2.7	3.2	N/A	69000	1780	FD 2500	2500	69500	1948					
315	BX 355MBK 4	1791	1679	479	96.7 96.6 96.1	0.85	8.5	3.1	3.2	N/A	72000	1820	FD 2500	2500	72500	1988					
355	BX 355MCK 4	1792	1893	541	96.7 96.5 96.9	0.86	7.2	2.4	3.1	N/A	84000	2140	FD 2500	2500	84500	2308					

Nota: per maggiori dettagli sulle certificazioni energetiche disponibili, consultare la sezione dedicata del catalogo.

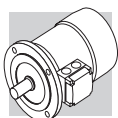





4 P	1800 min <sup>-1</sup> - S1														60 Hz - IE3							
	freno c.c.														freno c.a.							
	P <sub>n</sub> kW		n min <sup>-1</sup>	M <sub>n</sub> Nm	I <sub>n</sub> 460V A	η%			cos φ	$\frac{I_s}{I_n}$	$\frac{M_s}{M_n}$	$\frac{M_a}{M_n}$	KVA code	J <sub>m</sub> x 10 <sup>-4</sup> kgm <sup>2</sup>	IM B5 	FD			FA			
100%						75%	50%	Mod								M <sub>b</sub> Nm	J <sub>m</sub> x 10 <sup>-4</sup> kgm <sup>2</sup>	IM B5 	Mod	M <sub>b</sub> Nm	J <sub>m</sub> x 10 <sup>-4</sup> kgm <sup>2</sup>	IM B5 
0.75	<b>MX 2SB</b>	4	1755	4.1	1.48	85.5	86.4	83.9	0.73	3.7	2.5	L	27	16	FD 14	15	29	20.2	FA 14	15	29	20.1
1.1	<b>MX 3SA</b>	4	1755	6.0	2.19	86.5	86.0	83.0	0.73	3.3	2.5	L	35	17	FD 15	15	26	24	FA 15	15	26	24
1.5	<b>MX 3SB</b>	4	1755	8.2	2.96	86.5	87.2	85.0	0.72	3.7	2.9	L	43	20	FD 15	26	47	27	FA 15	26	47	27
2.2	<b>MX 3LA</b>	4	1760	11.9	4.4	89.5	88.6	86.2	0.71	4.8	3.6	N	73	29	FD 15	40	77	36	FA 15	40	77	36
3	<b>MX 3LB</b>	4	1750	16.4	5.9	89.5	88.9	86.7	0.71	4.4	3.3	M	73	29	FD 15	40	77	36	FA 15	40	77	36
3.7	<b>MX 4SA</b>	4	1770	20.0	6.6	89.5	89.8	87.7	0.78	4.7	3.4	M	225	45	FD 56	75	235	58	FA 06	75	235	59
5.5	<b>MX 4SB</b>	4	1770	30	9.9	91.7	92.0	90.2	0.76	5.1	4.6	N	410	77	FD 56	75	420	90	FA 06	75	420	91
7.5	<b>MX 4LA</b>	4	1770	41	13.4	91.7	91.3	89.7	0.76	4.9	4.4	N	410	77	FD 06	100	420	90	FA 07	100	420	95
9.2	<b>MX 5SA</b>	4	1770	50	15.6	92.4	92.5	91.6	0.8	4.1	2.6	L	650	95	FD 08	170	725	125	FA 08	170	725	124
11	<b>MX 5SB</b>	4	1770	59	18.2	92.4	92.9	92.0	0.82	4.0	2.4	L	780	110	FD 08	170	855	140	FA 08	170	855	139
15	<b>MX 5LA</b>	4	1770	81	24.5	93.0	93.5	92.5	0.81	4.8	2.8	M	890	121	FD 08	200	965	151	FA 08	200	965	150

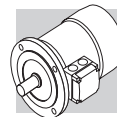

M17 DIMENSIONI MOTORI BX-MX

**BX - IM B5 - CE/CCC**

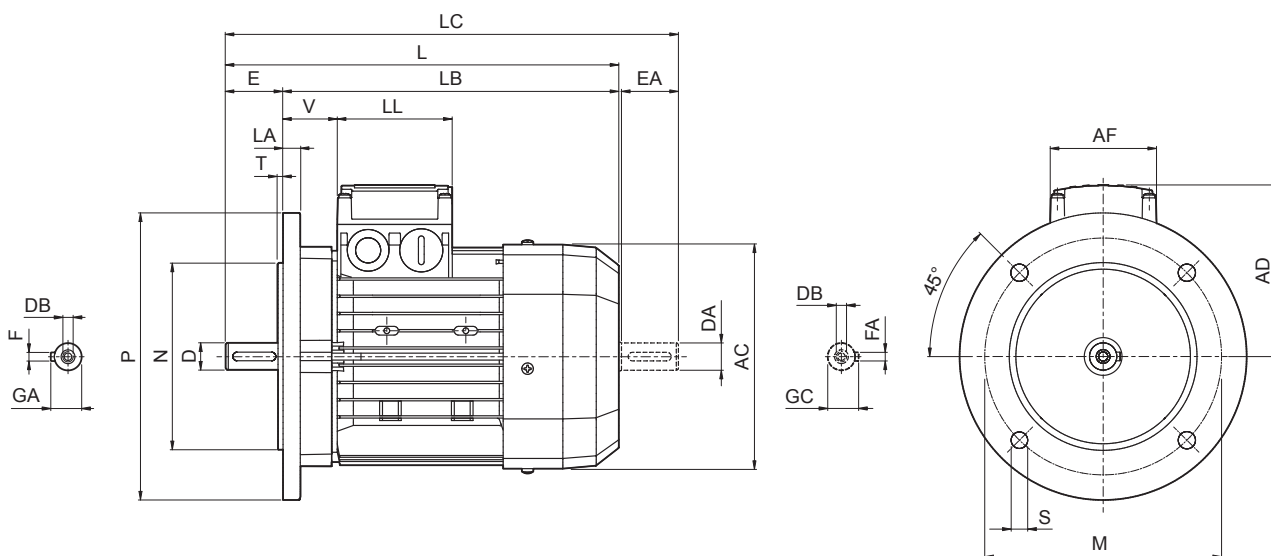

	Albero					Flangia						Motore							
	D DA	E EA	DB	GA GC	F FA	M	N	P	S	T	LA	AC	L	LB	LC	AD	AF	LL	V
<b>BX 80 B</b>	19 14 <sup>(1)</sup>	40 30 <sup>(1)</sup>	M6	21.5 16 <sup>(1)</sup>	6 5 <sup>(1)</sup>	165	130	200	11.5	3.5	11.5	156	320	280	351	119	74	80	38
<b>BX 90 S</b>	24 19 <sup>(1)</sup>	50 40 <sup>(1)</sup>	M8	27 21.5 <sup>(1)</sup>	8 6 <sup>(1)</sup>							176	326	276	368	133	98	98	44
<b>BX 90 LA</b>			M6 <sup>(1)</sup>																
<b>BX 100 LA</b>	28 24 <sup>(1)</sup>	60 50 <sup>(1)</sup>	M10	31 27 <sup>(1)</sup>	8 8 <sup>(1)</sup>	215	180	250	14	4	14	195	410	350	462	142	98	98	50
<b>BX 100 LB</b>												219	430	370	482	157			52
<b>BX 112 M</b>												20	258	493	413	556			193
<b>BX 132 SB</b>	38 28 <sup>(1)</sup>	80 60 <sup>(1)</sup>	M12	41 31 <sup>(1)</sup>	10 8 <sup>(1)</sup>	265	230	300	15	4	20	258	493	413	556	193	118	118	58
<b>BX 132 MA</b>												528	448	591	596	486	680	245	187
<b>BX 160 MA</b>	42 38 <sup>(1)</sup>	110 80 <sup>(1)</sup>	M16	45 41 <sup>(1)</sup>	12 10 <sup>(1)</sup>	300	250	350	18.5	15	310	640	530	724	245	187	187	51	
<b>BX 160 MB</b>												596	486	680					
<b>BX 160 L</b>												640	530	724	245				187
<b>BX 180 M</b>	48 42 <sup>(1)</sup>	110 110 <sup>(1)</sup>	M16	51.5 45 <sup>(1)</sup>	14 12 <sup>(1)</sup>	350	300	400	19	5	18	348	708	598	823	261	300	311	55
<b>BX 180 L</b>												423	821	711	934	328			48
<b>BX 200LA</b>	55 45 <sup>(1)</sup>	140 110 <sup>(1)</sup>	M20	59 48.5 <sup>(1)</sup>	16 14 <sup>(1)</sup>	500	450	550	18	20	24	423	821	711	934	328	300	311	55
<b>BX 225SA</b>	60 55 <sup>(1)</sup>			64 59 <sup>(1)</sup>	18 16 <sup>(1)</sup>							465	879	739	1001	348			48
<b>BX 225SB</b>	65 55 <sup>(1)</sup>			69 59 <sup>(1)</sup>	18 16 <sup>(1)</sup>							514	884	744	1010	376			
<b>BX 250MA</b>	75 65 <sup>(1)</sup>	140 140 <sup>(1)</sup>	M20	79.5 69 <sup>(1)</sup>	20 18 <sup>(1)</sup>	600	550	660	23	6	23	567	1088	948	1238	482	434	306	43
<b>BX 280SA</b>	75 65 <sup>(1)</sup>			79.5 69 <sup>(1)</sup>	20 18 <sup>(1)</sup>							567	1088	948	1238	482	434	306	43
<b>BX 280SB</b>	75 65 <sup>(1)</sup>			79.5 69 <sup>(1)</sup>	20 18 <sup>(1)</sup>							567	1088	948	1238	482	434	306	43
<b>BX 315SA</b>	80 75 <sup>(1)</sup>	170 140 <sup>(1)</sup>	M20	85 79.5 <sup>(1)</sup>	22 20 <sup>(1)</sup>	600	550	660	23	6	25	645	1204	1034	1352	537	473	347	42
<b>BX 315SB</b>												645	1204	1034	1352	537	473	347	42
<b>BX 315SC</b>												645	1204	1034	1352	537	473	347	42
<b>BX 315MA</b>	90 75 <sup>(1)</sup>	210 170 <sup>(1)</sup>	M24	95 79.5 <sup>(1)</sup>	25 20 <sup>(1)</sup>	740	680	800	23	6	25	1315	1145	1463	603	694	413	50	
<b>BX 355MA</b>	90 75 <sup>(1)</sup>			95 79.5 <sup>(1)</sup>	25 20 <sup>(1)</sup>							1315	1145	1463					
<b>BX 355MB</b>	100 75 <sup>(1)</sup>			106 79.5 <sup>(1)</sup>	28 20 <sup>(1)</sup>							1479	1269	1659					603
<b>BX 355MC</b>	100 75 <sup>(1)</sup>	210 170 <sup>(1)</sup>	M24	106 79.5 <sup>(1)</sup>	28 20 <sup>(1)</sup>	740	680	800	23	6	25	740	1479	1269	1659	603	694	413	50

N.B.: 1) Queste dimensioni sono riferite alla seconda estremità d'albero (PS).

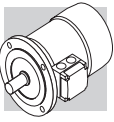

# BX - IM B14 - CE/CCC

**BX-MX**

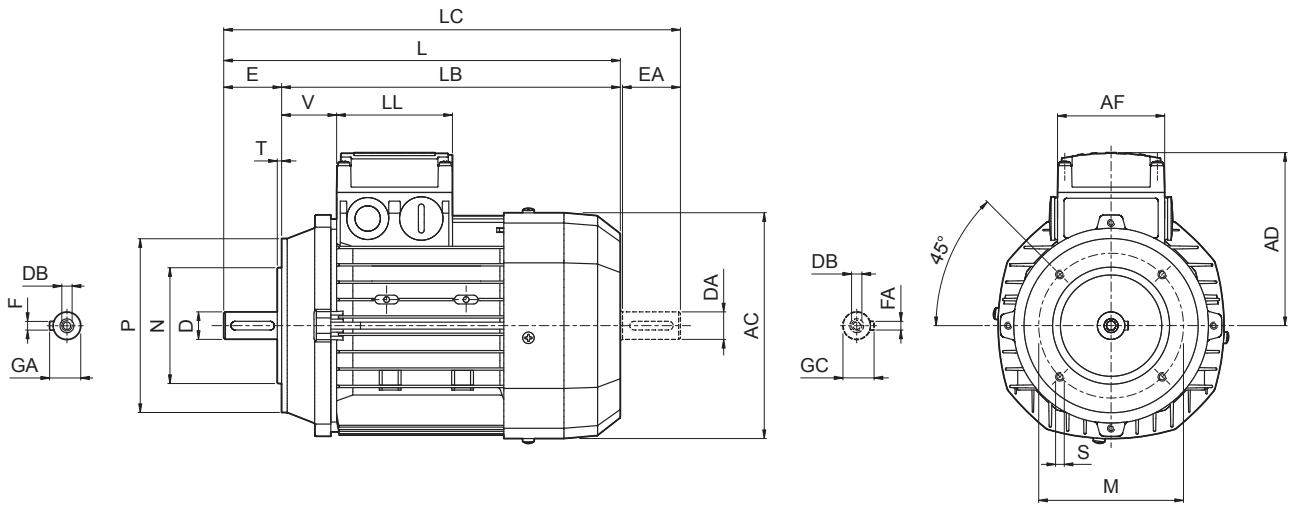

	Albero					Cassa					Motore							
	D DA	E EA	DB	GA GC	F FA	M	N	P	S	T	AC	L	LB	LC	AD	AF	LL	V
<b>BX 80 B</b>	19 14 <sup>(1)</sup>	40 30 <sup>(1)</sup>	M6 M5 <sup>(1)</sup>	21.5 16 <sup>(1)</sup>	6 5 <sup>(1)</sup>	100	80	120	M6		156	320	280	351	119	74	80	38
<b>BX 90 S</b>	24 19 <sup>(1)</sup>	50 40 <sup>(1)</sup>	M8 M6 <sup>(1)</sup>	27 21.5 <sup>(1)</sup>	8 6 <sup>(1)</sup>	115	95	140	M8	3	176	326	276	368	133	98	98	44
<b>BX 90 LA</b>																		
<b>BX 100 LA</b>	28 24 <sup>(1)</sup>	60 50 <sup>(1)</sup>	M10 M8 <sup>(1)</sup>	31 27 <sup>(1)</sup>	8 8 <sup>(1)</sup>	130	110	160	M8	3.5	195	410	350	462	142	98	98	50
<b>BX 100 LB</b>																		
<b>BX 112 M</b>																		
<b>BX 132 SB</b>	38 28 <sup>(1)</sup>	80 60 <sup>(1)</sup>	M12 M10 <sup>(1)</sup>	41 31 <sup>(1)</sup>	10 8 <sup>(1)</sup>	165	130	200	M10	4	258	493	413	556	193	118	118	58

N.B.: 1) Queste dimensioni sono riferite alla seconda estremità d'albero (PS).



**BX - IM B5 - FD/FA - CE/CCC**

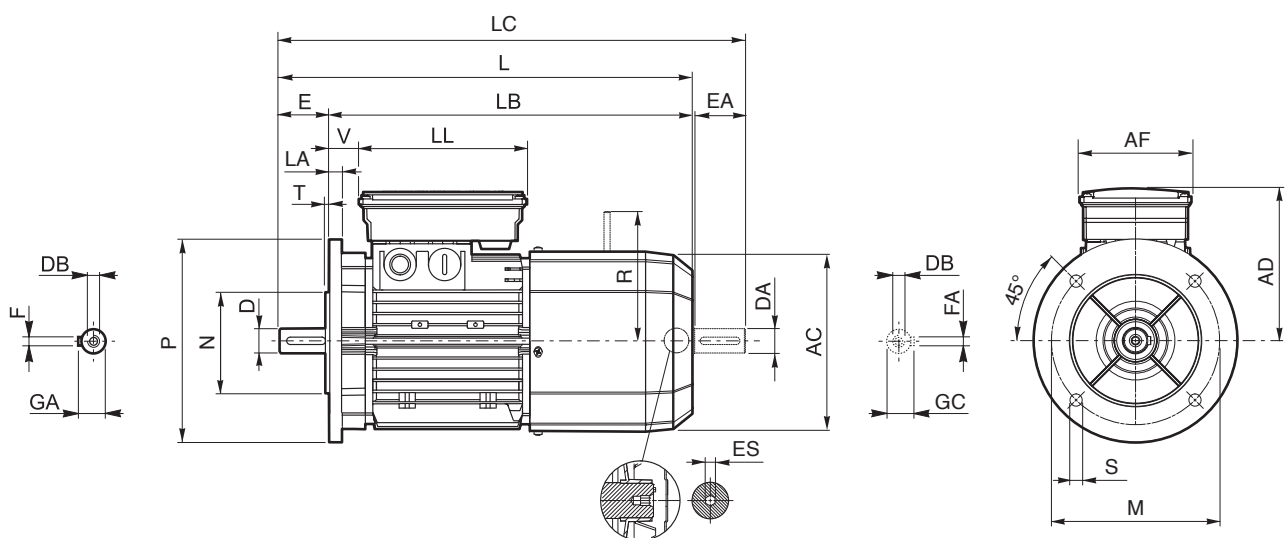

	Albero					Flangia						Motore										
	D DA	E EA	DB	GA GC	F FA	M	N	P	S	T	LA	AC	L	LB	LC	AD	AF	LL	V	R		ES <sup>(2)</sup>
																				FD	FA	
<b>BX 80 B</b>	19 14 <sup>(1)</sup>	40 30 <sup>(1)</sup>	M6 M5 <sup>(1)</sup>	21.5 16 <sup>(1)</sup>	6 5 <sup>(1)</sup>							156	392	352	423	143	98	133	25			5
<b>BX 90 S</b>	24 19 <sup>(1)</sup>	50 40 <sup>(1)</sup>	M8 M6 <sup>(1)</sup>	27 21.5 <sup>(1)</sup>	8 6 <sup>(1)</sup>	165	130	200	11.5	3.5	11.5	176	410	360	452	146			32			
<b>BX 90 LA</b>																						
<b>BX 100 LA</b>	28 24 <sup>(1)</sup>	60 50 <sup>(1)</sup>	M10 M8 <sup>(1)</sup>	31 27 <sup>(1)</sup>	8 8 <sup>(1)</sup>	215	180	250	14	4	14	195	502	442	554	155	110	165	37	160	160	6
<b>BX 100 LB</b>																						
<b>BX 112 M</b>												15	219	527	467	579	170		39	199	198	
<b>BX 132 SB</b>	38 28 <sup>(1)</sup>	80 60 <sup>(1)</sup>	M12 M10 <sup>(1)</sup>	41 31 <sup>(1)</sup>	10 8 <sup>(1)</sup>	265	230	300	16	258	603	523	667	210	140	188	46	204	200	226		
<b>BX 132 MA</b>																						
<b>BX 160 MA</b>	42 38 <sup>(1)</sup>	110 80 <sup>(1)</sup>	M16 M12 <sup>(1)</sup>	45 41 <sup>(1)</sup>	12 10 <sup>(1)</sup>	300	250	350	18.5	5	15	310	736	626	820	245	187	187	51	266	247	
<b>BX 160 MB</b>																						
<b>BX 160 L</b>												780	670	864								
<b>BX 180 M</b>	48 42 <sup>(1)</sup>	110 110 <sup>(1)</sup>	M16 M16 <sup>(1)</sup>	51.5 45 <sup>(1)</sup>	14 12 <sup>(1)</sup>	350	300	400	19	5	18	348	866	756	981	261			52	305		
<b>BX 180 L</b>																						
<b>BX 200LA</b>	55 45 <sup>(1)</sup>			59 48.5 <sup>(1)</sup>	16 14 <sup>(1)</sup>							423	982	872	1095	328			55	275		
<b>BX 225SA</b>	60 55 <sup>(1)</sup>	140 110 <sup>(1)</sup>	M20 M20 <sup>(1)</sup>	64 59 <sup>(1)</sup>	18 16 <sup>(1)</sup>	400	350	450	19	5	20	465	1058	918	1180	348	300	311	48	308		
<b>BX 225SB</b>																						
<b>BX 250MA</b>	65 55 <sup>(1)</sup>			69 59 <sup>(1)</sup>							24	514	1099	959	1225	376				313		
<b>BX 280SA</b>	75 65 <sup>(1)</sup>	140 140 <sup>(1)</sup>	M20 M20 <sup>(1)</sup>	79.5 69 <sup>(1)</sup>	20 18 <sup>(1)</sup>	500	450	550	18	23	567	1340	1200	1490	482	434	306	43				
<b>BX 280SB</b>																						
<b>BX 315SA</b>	80 75 <sup>(1)</sup>	170 140 <sup>(1)</sup>	M24 M20 <sup>(1)</sup>	85 79.5 <sup>(1)</sup>	22 20 <sup>(1)</sup>	600	550	660	23	6	25	645	1497	1327	1645	537	473	347	42	500		
<b>BX 315SB</b>																						
<b>BX 315SC</b>												1607	1437	1755								
<b>BX 315MA</b>	90 75 <sup>(1)</sup>	210 170 <sup>(1)</sup>	M24 M20 <sup>(1)</sup>	95 79.5 <sup>(1)</sup>	25 20 <sup>(1)</sup>	740	680	800				740	1790	1580	1970	603	694	413	50			
<b>BX 355MA</b>																						
<b>BX 355MB</b>												1825	1615	2005								
<b>BX 355MC</b>																						

N.B.: 1) Queste dimensioni sono riferite alla seconda estremità d'albero (PS). 2) L'esagono ES non è presente con l'opzione PS.



# BX - IM B14 - FD/FA - CE/CCC

**BX-MX**

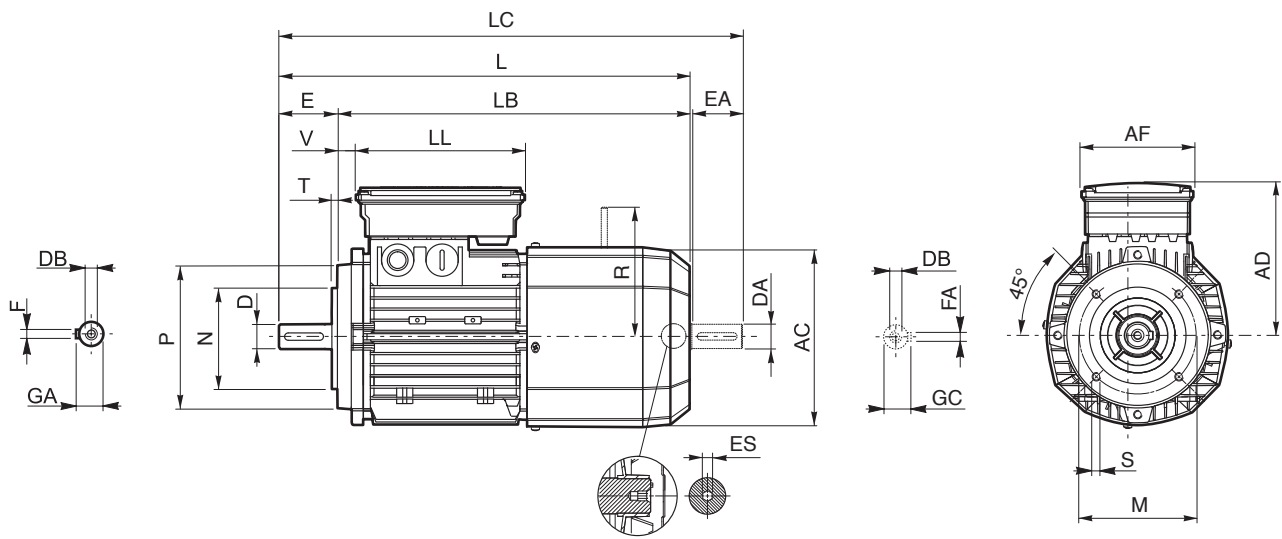

	Albero					Cassa					Motore											
	D	E	DB	GA	F	M	N	P	S	T	AC	L	LB	LC	AD	AF	LL	V	R		ES	
	DA	EA		GC	FA														FD	FA	(2)	
<b>BX 80 B</b>	19 14 <sup>(1)</sup>	40 30 <sup>(1)</sup>	M6 M5 <sup>(1)</sup>	21.5 16 <sup>(1)</sup>	6 5 <sup>(1)</sup>	100	80	120	M6		156	392	352	423	143	98	133	25		129	134	5
<b>BX 90 S</b>	24 19 <sup>(1)</sup>	50 40 <sup>(1)</sup>	M8 M6 <sup>(1)</sup>	27 21.5 <sup>(1)</sup>	8 6 <sup>(1)</sup>	115	95	140		3	176	410	360	452	146			32				6
<b>BX 90 LA</b>									M8													
<b>BX 100 LA</b>										3.5	195	502	442	554	155	110	165		37	160	160	
<b>BX 100 LB</b>	28 24 <sup>(1)</sup>	60 50 <sup>(1)</sup>	M10 M8 <sup>(1)</sup>	31 27 <sup>(1)</sup>	8 8 <sup>(1)</sup>	130	110	160			219	527	467	579	170			39	199	198		
<b>BX 112 M</b>																						
<b>BX 132 SB</b>	38 28 <sup>(1)</sup>	80 60 <sup>(1)</sup>	M12 M10 <sup>(1)</sup>	41 31 <sup>(1)</sup>	10 8 <sup>(1)</sup>	165	130	200	M10	4	258	603	523	667		210	140	188	46	204	200	
<b>BX 132 MA</b>												627	547	690						226		

N.B.: 1) Queste dimensioni sono riferite alla seconda estremità d'albero (PS). 2) L'esagono ES non è presente con l'opzione PS.



**BX-MX**

**BX - IM B5 - CUS/NBR/EECA**

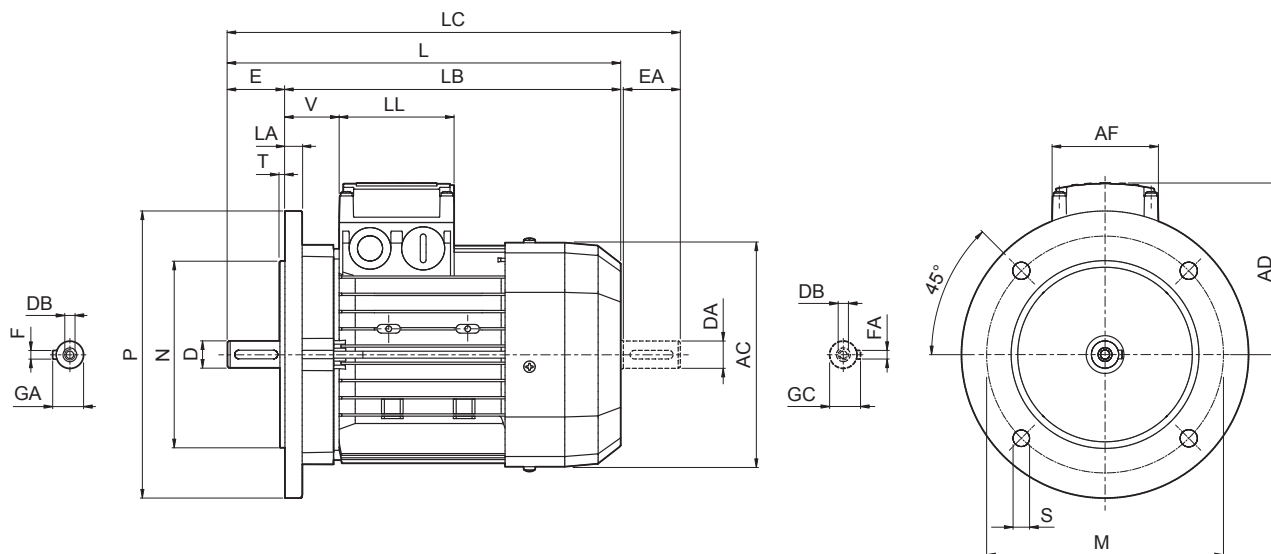

	Albero					Flangia						Motore								
	D DA	E EA	DB	GA GC	F FA	M	N	P	S	T	LA	AC	L	LB	LC	AD	AF	LL	V	
<b>BX 90 SR</b>	19 19 <sup>(1)</sup>	40 40 <sup>(1)</sup>	M6 M6 <sup>(1)</sup>	21.5 21.5 <sup>(1)</sup>	6 6 <sup>(1)</sup>								316		358					
<b>BX 90 S</b>	24 19 <sup>(1)</sup>	50 40 <sup>(1)</sup>	M8 M6 <sup>(1)</sup>	27 21.5 <sup>(1)</sup>	8 6 <sup>(1)</sup>	165	130	200	11.5	3.5	11.5	176	326	276	368	133			44	
<b>BX 90 LA</b>																	98	98		
<b>BX 100 LA</b>											14	195	410	350	462	142			50	
<b>BX 100 LB</b>	28 24 <sup>(1)</sup>	60 50 <sup>(1)</sup>	M10 M8 <sup>(1)</sup>	31 27 <sup>(1)</sup>	8 8 <sup>(1)</sup>	215	180	250												
<b>BX 112 M</b>									14	4		15	219	430	370	482	157		52	
<b>BX 132 SB</b>	38 28 <sup>(1)</sup>	80 60 <sup>(1)</sup>	M12 M10 <sup>(1)</sup>	41 31 <sup>(1)</sup>	10 8 <sup>(1)</sup>	265	230	300				20	258	552	472	615	193	118	118	58
<b>BX 132 MA</b>																				
<b>BX 160 MA</b>													596	486	680					
<b>BX 160 MB</b>	42 38 <sup>(1)</sup>	110 80 <sup>(1)</sup>	M16 M12 <sup>(1)</sup>	45 41 <sup>(1)</sup>	12 10 <sup>(1)</sup>						15	310	640	530	724	245			51	
<b>BX 160 L</b>						300	250	350	18.5	5							187	187		
<b>BX 180 M</b>	48 42 <sup>(1)</sup>	110 110 <sup>(1)</sup>	M16 M16 <sup>(1)</sup>	51.5 45 <sup>(1)</sup>	14 12 <sup>(1)</sup>						18	348	708	598	823	261			52	
<b>BX 180 L</b>																				
<b>BX 200LAK</b>	55 45 <sup>(1)</sup>	110 110 <sup>(1)</sup>	M20 M20 <sup>(1)</sup>	59 48.5 <sup>(1)</sup>	16 14 <sup>(1)</sup>	350	300	400	19	5	20	423	821	711	934	328	300	311	55	
<b>BX 225SAK</b>	60 55 <sup>(1)</sup>	140 110 <sup>(1)</sup>	M20 M20 <sup>(1)</sup>	64 59 <sup>(1)</sup>	18 16 <sup>(1)</sup>	400	350	450	19	5	20	465	879	739	1001	348	300	311		
<b>BX 225SBK</b>																			48	
<b>BX 250MAK</b>	65 55 <sup>(1)</sup>	140 110 <sup>(1)</sup>	M20 M20 <sup>(1)</sup>	69 59 <sup>(1)</sup>	18 16 <sup>(1)</sup>	500	450	550	19	5	24	514	884	744	1010	376	300	311		
<b>BX 280SAK</b>	75 65 <sup>(1)</sup>	140 140 <sup>(1)</sup>	M20 M20 <sup>(1)</sup>	79.5 69 <sup>(1)</sup>	20 18 <sup>(1)</sup>	500	450	550	18	5	23	567	1088	948	1238	482	434	306	43	
<b>BX 280SBK</b>																				
<b>BX 315SAK</b>																				
<b>BX 315SBK</b>	80 75 <sup>(1)</sup>	170 140 <sup>(1)</sup>	M20 M20 <sup>(1)</sup>	85 79.5 <sup>(1)</sup>	22 20 <sup>(1)</sup>	600	550	660	23	6	25	645	1204	1034	1352	537	473	347	42	
<b>BX 315SCK</b>													1315	1145	1453					
<b>BX 355SAK</b>																				
<b>BX 355MAK</b>	100 75 <sup>(1)</sup>	210 170 <sup>(1)</sup>	M24 M20 <sup>(1)</sup>	106 79.5 <sup>(1)</sup>	28 20 <sup>(1)</sup>	740	680	800	23	6	25	740	1479	1269	1659	603	694	413	50	
<b>BX 355MBK</b>																				
<b>BX 355MCK</b>													1584	1374	1764					

N.B.: 1) Queste dimensioni sono riferite alla seconda estremità d'albero (PS).



# BX - IM B14 - CUS

**BX-MX**

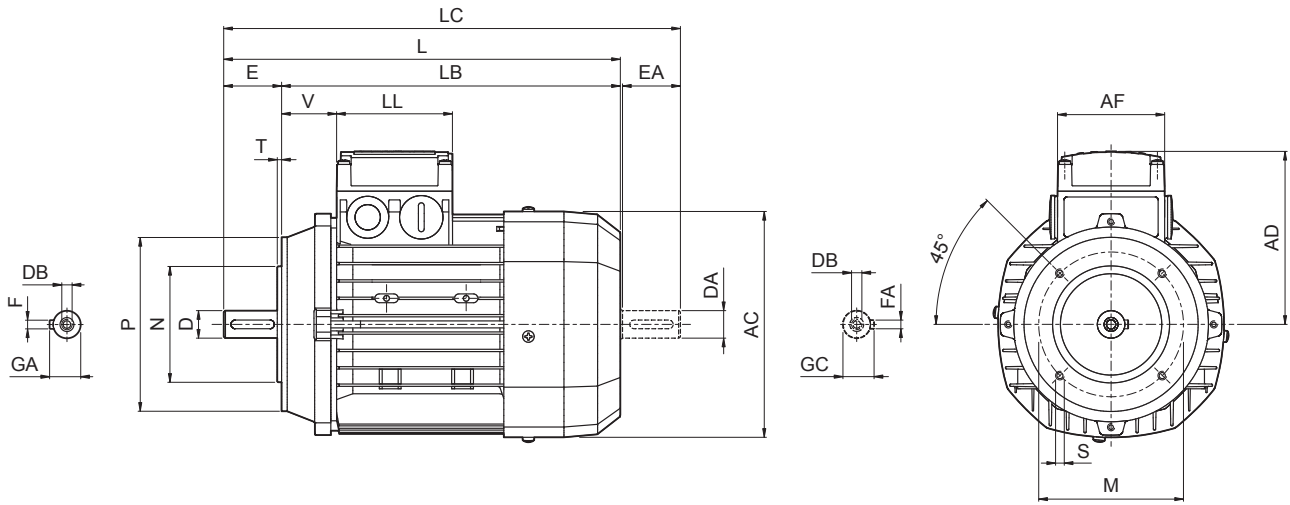

	Albero					Cassa					Motore													
	D DA	E EA	DB	GA GC	F FA	M	N	P	S	T	AC	L	LB	LC	AD	AF	LL	V						
<b>BX 90 SR</b>	19 19 <sup>(1)</sup>	40 40 <sup>(1)</sup>	M6 M6 <sup>(1)</sup>	21.5 21.5 <sup>(1)</sup>	6 6 <sup>(1)</sup>	100	80	120	M6	3	176	316	276	358	133	98	98	44						
<b>BX 90 S</b>	24 19 <sup>(1)</sup>	50 40 <sup>(1)</sup>	M8 M6 <sup>(1)</sup>	27 21.5 <sup>(1)</sup>	8 6 <sup>(1)</sup>	115	95	140	M8			3.5		195					326	462	142			
<b>BX 90 LA</b>											219		430						370			482	157	50
<b>BX 100 LA</b>	28 24 <sup>(1)</sup>	60 50 <sup>(1)</sup>	M10 M8 <sup>(1)</sup>	31 27 <sup>(1)</sup>	8 8 <sup>(1)</sup>	130	110	160	M10	4	258	552	472	615	193	118	118	58						
<b>BX 100 LB</b>																			219	430	370	482	157	52
<b>BX 112 M</b>																			219	430	370	482	157	52
<b>BX 132 SB</b>	38 28 <sup>(1)</sup>	80 60 <sup>(1)</sup>	M12 M10 <sup>(1)</sup>	41 31 <sup>(1)</sup>	10 8 <sup>(1)</sup>	165	130	200	M10	4	258	552	472	615	193	118	118	58						
<b>BX 132 MA</b>																			219	430	370	482	157	52

N.B.: 1) Queste dimensioni sono riferite alla seconda estremità d'albero (PS).





**BX-MX**

**BX - IM B5 - FD/FA - CUS/NBR/EECA**

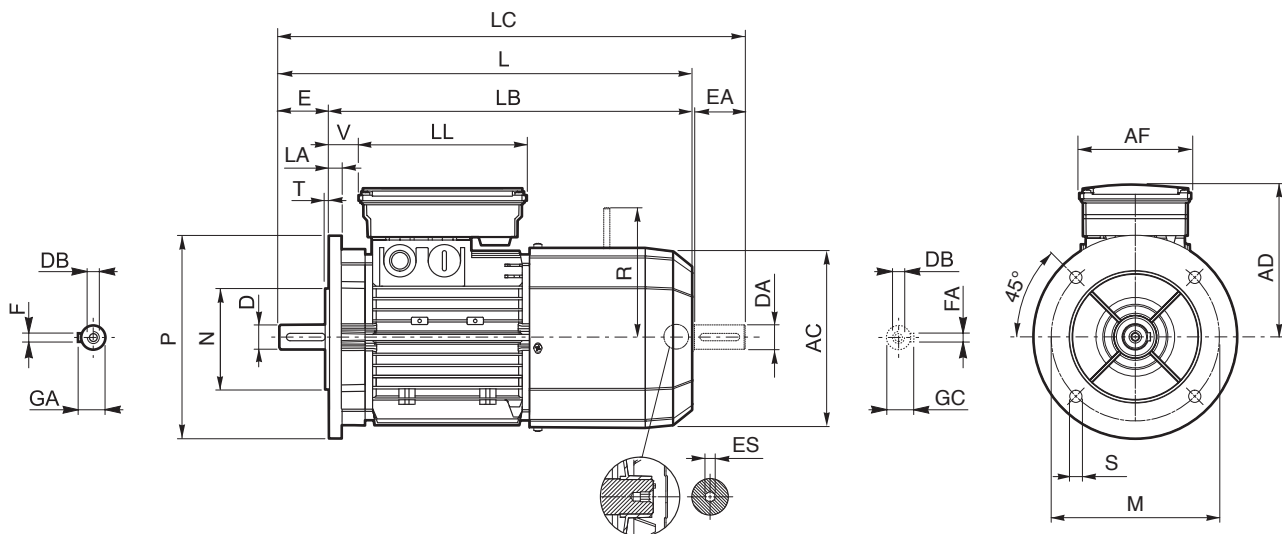

	Albero					Flangia						Motore											
	D	E	DB	GA	F	M	N	P	S	T	LA	AC	L	LB	LC	AD	AF	LL	V	R		ES	
	DA	EA	M	GC	FA															FD	FA	(2)	
<b>BX 90 SR</b>	19 19 <sup>(1)</sup>	40 40 <sup>(1)</sup>	M6 M6 <sup>(1)</sup>	21.5 21.5 <sup>(1)</sup>	6 6 <sup>(1)</sup>								400		442								
<b>BX 90 S</b>	24 19 <sup>(1)</sup>	50 40 <sup>(1)</sup>	M8 M6 <sup>(1)</sup>	27 21.5 <sup>(1)</sup>	8 6 <sup>(1)</sup>	165	130	200	11.5	3.5	11.5	176	410	360	452	146			32	129	134		
<b>BX 90 LA</b>																	110	165					
<b>BX 100 LA</b>																							
<b>BX 100 LB</b>	28 24 <sup>(1)</sup>	60 50 <sup>(1)</sup>	M10 M8 <sup>(1)</sup>	31 27 <sup>(1)</sup>	8 8 <sup>(1)</sup>	215	180	250			14	195	502	442	554	155			37	160	160	6	
<b>BX 112 M</b>									14	4	15	219	527	467	579	170			39	199	198		
<b>BX 132 SB</b>	38 28 <sup>(1)</sup>	80 60 <sup>(1)</sup>	M12 M10 <sup>(1)</sup>	41 31 <sup>(1)</sup>	10 8 <sup>(1)</sup>	265	230	300			16	258	661	581	724	210	140	188	46	204	200		
<b>BX 132 MA</b>																					226		
<b>BX 160 MA</b>													736	626	820								
<b>BX 160 MB</b>	42 38 <sup>(1)</sup>	110 80 <sup>(1)</sup>	M16 M12 <sup>(1)</sup>	45 41 <sup>(1)</sup>	12 10 <sup>(1)</sup>						15	310	780	670	864	245			51	266	247		
<b>BX 160 L</b>						300	250	350	18.5	5							187	187					
<b>BX 180 M</b>	48 42 <sup>(1)</sup>		M16	51.5 45 <sup>(1)</sup>	14 12 <sup>(1)</sup>						18	348	866	756	981	261			52	305			
<b>BX 180 L</b>		110 110 <sup>(1)</sup>	M16																				
<b>BX 200LAK</b>	55 45 <sup>(1)</sup>		M20 M16 <sup>(1)</sup>	59 48.5 <sup>(1)</sup>	16 14 <sup>(1)</sup>	350	300	400					417	967	857	1082	328			55	275		
<b>BX 225SAK</b>	60 55 <sup>(1)</sup>	140 110 <sup>(1)</sup>		64 59 <sup>(1)</sup>	18 16 <sup>(1)</sup>	400	350	450	19		20		460	1065	925	1180	348	300	311	48	308		
<b>BX 225SBK</b>																							
<b>BX 250MAK</b>	65 55 <sup>(1)</sup>			69 59 <sup>(1)</sup>							24		510	1070	930	1240	376				313		
<b>BX 280SAK</b>	75 65 <sup>(1)</sup>	140 140 <sup>(1)</sup>	M20 M20 <sup>(1)</sup>	79.5 69 <sup>(1)</sup>	20 18 <sup>(1)</sup>	500	450	550	18		23		564	1284	1144	1379	482	434	306	43			
<b>BX 280SBK</b>																							
<b>BX 315SAK</b>													1493	1323	1643								
<b>BX 315SBK</b>	80 75 <sup>(1)</sup>	170 140 <sup>(1)</sup>		85 79.5 <sup>(1)</sup>	22 20 <sup>(1)</sup>	600	550	660				639	1530	1360	1680	537	473	347	42		500		
<b>BX 315SCK</b>													1604	1434	1791								
<b>BX 355SAK</b>									23	6	25												
<b>BX 355MAK</b>	100 90 <sup>(1)</sup>	210 170 <sup>(1)</sup>	M24 M24 <sup>(1)</sup>	106 95 <sup>(1)</sup>	28 25 <sup>(1)</sup>	740	680	800				725	1722	1512	1902	603	694	413	50				
<b>BX 355MBK</b>																							
<b>BX 355MCK</b>													1827	1617	2082								

N.B.: 1) Queste dimensioni sono riferite alla seconda estremità d'albero (PS). 2) L'esagono ES non è presente con l'opzione PS.



# BX - IM B14 - FD/FA - CUS

**BX-MX**

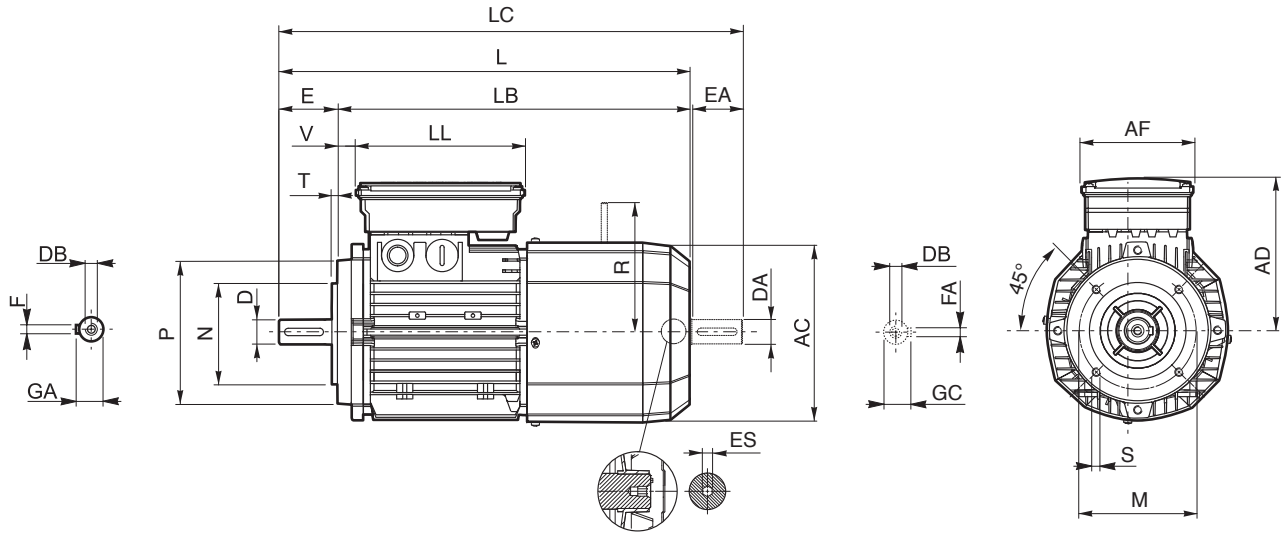

	Albero					Cassa					Motore												
	D	E	DB	GA	F	M	N	P	S	T	AC	L	LB	LC	AD	AF	LL	V	R		ES <sup>(2)</sup>		
	DA	EA	M	GC	FA														FD	FA			
<b>BX 90 SR</b>	19 19 <sup>(1)</sup>	40 40 <sup>(1)</sup>	M6 M6 <sup>(1)</sup>	21.5 21.5 <sup>(1)</sup>	6 6 <sup>(1)</sup>	100	80	120	M6			400		442									
<b>BX 90 S</b>	24 19 <sup>(1)</sup>	50 40 <sup>(1)</sup>	M8 M6 <sup>(1)</sup>	27 21.5 <sup>(1)</sup>	8 6 <sup>(1)</sup>	115	95	140		3	176		360		146			32		129	134		
<b>BX 90 LA</b>												410		452			110	165					
<b>BX 100 LA</b>									M8											160	160		
<b>BX 100 LB</b>	28 24 <sup>(1)</sup>	60 50 <sup>(1)</sup>	M10 M8 <sup>(1)</sup>	31 27 <sup>(1)</sup>	8 8 <sup>(1)</sup>	130	110	160		3.5	195	502	442	554	155			37				6	
<b>BX 112 M</b>											219	527	467	579	170			39		199	198		
<b>BX 132 SB</b>	38 28 <sup>(1)</sup>	80 60 <sup>(1)</sup>	M12 M10 <sup>(1)</sup>	41 31 <sup>(1)</sup>	10 8 <sup>(1)</sup>	165	130	200	M10	4	258	661	581	724	210	140	188	46				200	
<b>BX 132 MA</b>																						226	

N.B.: 1) Queste dimensioni sono riferite alla seconda estremità d'albero (PS). 2) L'esagono ES non è presente con l'opzione PS.



**MX**

**BX-MX**

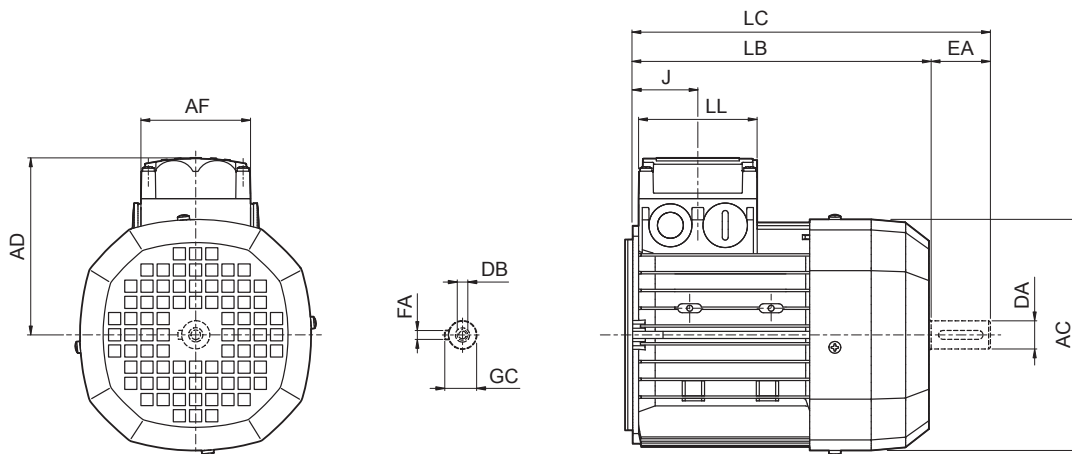

	Seconda estremità albero					Motore						
	DA	EA	DB	GC	FA	AC	LB	LC	AF	LL	J	AD
<b>MX 2SB</b>	14	30	M5	16	5	156	246	278	74	80	44	119
<b>MX 3SA</b>	24	50	M8	27	8	195	265	317	98	98	53.5	142
<b>MX 3SB</b>							305	357				
<b>MX 3LA</b>												
<b>MX 3LB</b>												
<b>MX 4SA</b>	28	60	M10	31		258	361	424	118	118	64.5	193
<b>MX 4SB</b>							396	459				
<b>MX 4LA</b>												
<b>MX 5SA</b>	38	80	M12	41	10	310	418	502	187	187	77	245
<b>MX 5SB</b>							462	546				
<b>MX 5LA</b>												



# MX\_FD/FA

**BX-MX**

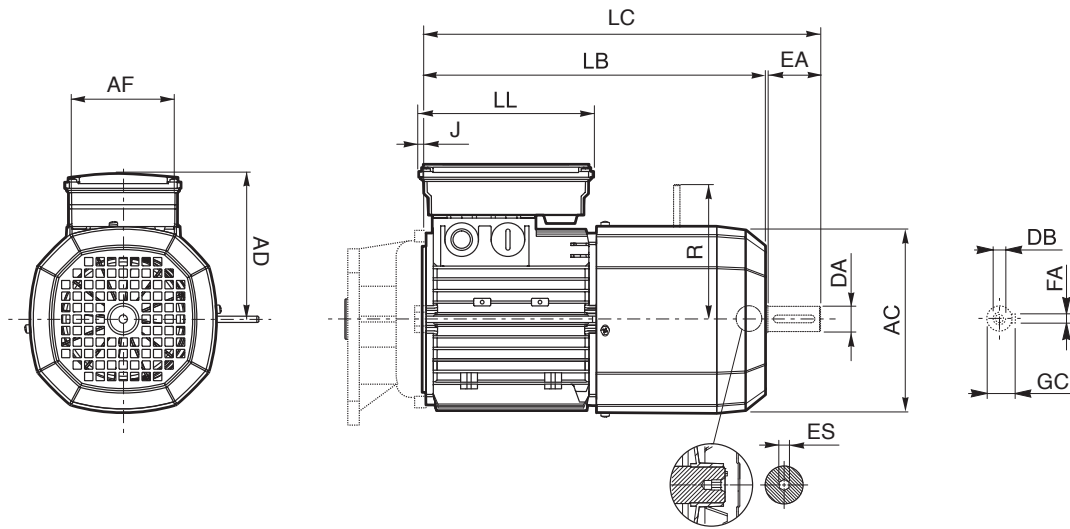

	Seconda estremità albero					Motore									
	DA	EA	DB	GC	FA	AC	LB	LC	AF	LL	J	AD	R FD FA		ES <sup>(1)</sup>
<b>MX 2SB</b>	14	30	M5	16	5	156	318	349	98	133	9	143	129	134	5
<b>MX 3SA</b>	24	50	M8	27	8	195	355	407	110	165	7	155	160	160	6
<b>MX 3SB</b>							397	450							
<b>MX 3LA</b>															
<b>MX 3LB</b>															
<b>MX 4SA</b>	28	60	M10	31	8	258	470	534	140	188	7	210	204	200	6
<b>MX 4SB</b>							494	558						226	
<b>MX 4LA</b>															
<b>MX 5SA</b>	38	80	M12	41	10	310	558	644	187	187	17	245	266	247	—
<b>MX 5SB</b>							602	686							
<b>MX 5LA</b>															

N.B.:

1) L'esagono ES non è presente con l'opzione PS.



# MX CUS

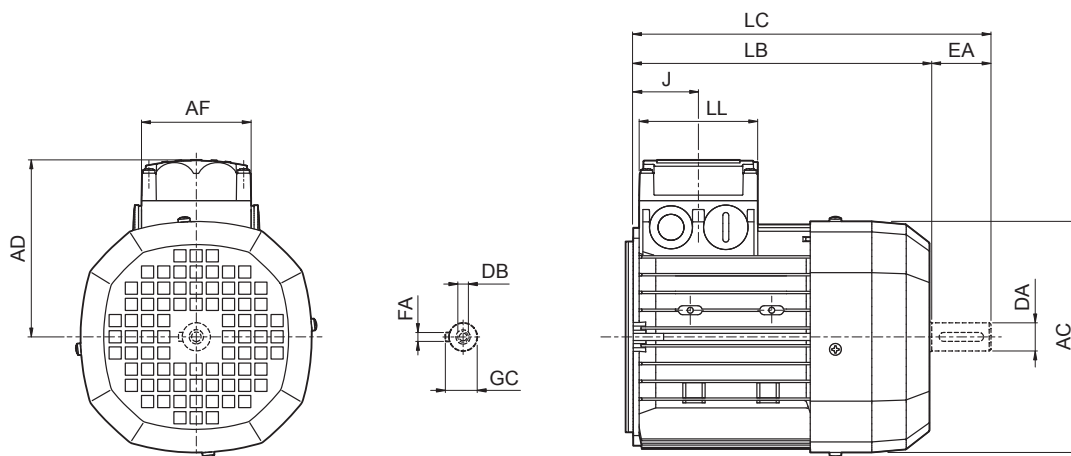

**BX-MX**

	Seconda estremità albero					Motore						
	DA	EA	DB	GC	FA	AC	LB	LC	AF	LL	J	AD
<b>MX 2SB</b>	14	30	M5	16	5	176	262	293	98	98	79	133
<b>MX 3SA</b>	24	50	M8	27	8	195	265	317				
<b>MX 3SB</b>							305	357				
<b>MX 3LA</b>												
<b>MX 3LB</b>												
<b>MX 4SA</b>	28	60	M10	31	10	258	361	424	118	118	64.5	193
<b>MX 4SB</b>							420	483				
<b>MX 4LA</b>												
<b>MX 5SA</b>	38	80	M12	41	10	310	418	502	187	187	77	245
<b>MX 5SB</b>							462	546				
<b>MX 5LA</b>												



# MX\_FD/FA\_CUS

**BX-MX**

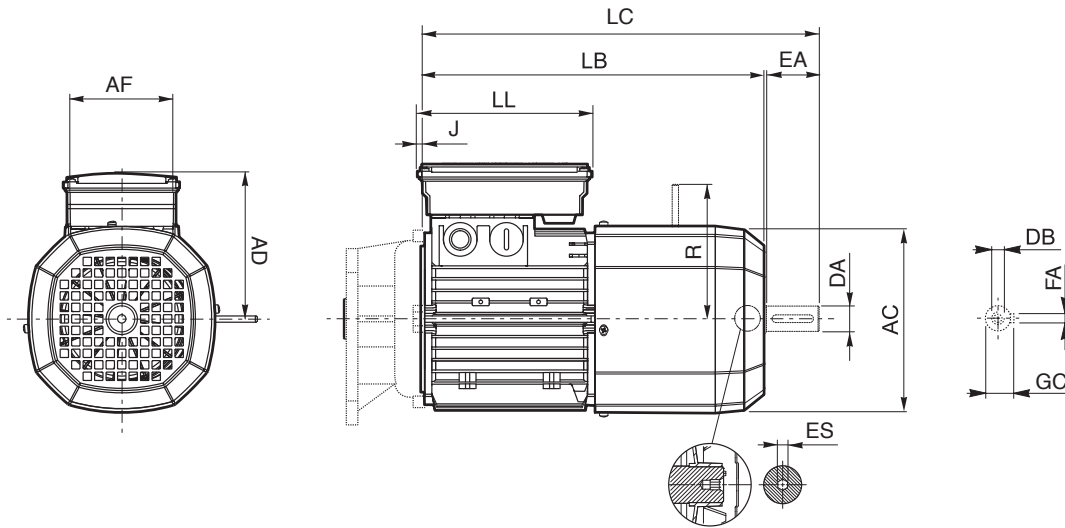

	Seconda estremità albero					Motore									
	DA	EA	DB	GC	FA	AC	LB	LC	AF	LL	J	AD	R FD FA		ES <sup>(1)</sup>
<b>MX 2SB</b>	14	30	M5	16	5	176	347	379			-17	146	129	134	6
<b>MX 3SA</b>	24	50	M8	27	8	195	355	407	110	165	7	155	160	160	
<b>MX 3SB</b>															
<b>MX 3LA</b>															
<b>MX 3LB</b>															
<b>MX 4SA</b>	28	60	M10	31	258	470	534	140	188	210	204	200			
<b>MX 4SB</b>												226			
<b>MX 4LA</b>															
<b>MX 5SA</b>	38	80	M12	41	10	310	558	644	187	187	17	245	266	247	—
<b>MX 5SB</b>															
<b>MX 5LA</b>															

N.B.:

1) L'esagono ES non è presente con l'opzione PS.



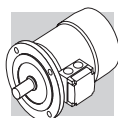



4 P		1500 min <sup>-1</sup> - S1											50 Hz - IE2															
P <sub>n</sub> kW	n min <sup>-1</sup>	M <sub>n</sub> Nm	I <sub>n</sub> 400V A	η%			cos φ	I <sub>s</sub> I <sub>n</sub>	M <sub>s</sub> M <sub>n</sub>	M <sub>a</sub> M <sub>n</sub>	J <sub>m</sub> x 10 <sup>-4</sup> kgm <sup>2</sup>	IM B5 Kg	freno c.c.				freno c.a.											
				100%	75%	50%							FD		FA													
				M <sub>b</sub> Nm	Z <sub>0</sub> 1/h	NB							SB	Mod	IM B5 Kg	M <sub>b</sub> Nm	Z <sub>0</sub> 1/h	Mod	IM B5 Kg	J <sub>m</sub> x 10 <sup>-4</sup> kgm <sup>2</sup>	M <sub>b</sub> Nm	Z <sub>0</sub> 1/h	J <sub>m</sub> x 10 <sup>-4</sup> kgm <sup>2</sup>	IM B5 Kg				
0.12	BE 63A	4	1360	0.84	0.45	59.1	59.6	53.5	0.65	3	2	2.2	2.3	3.5	FD 02	10000	13000	10000	13000	10000	13000	2.6	5.2	1.75	13000	2.6	5.2	
0.18	BE 63B	4	1370	1.25	0.64	64.7	65.1	59.8	0.62	3.5	2.3	2.5	3.3	5.1	FD 02	10000	13000	10000	13000	10000	13000	3	5.6	3.5	13000	3	5.4	
0.25	BE 71A	4	1380	1.73	0.68	68.5	68	62	0.78	4	2.3	2.5	5.8	5.1	FD 03	7700	11000	7700	11000	7700	11000	6.9	7.8	3.5	11000	6.9	7.5	
0.37	BE 71B	4	1385	2.55	1.05	72.7	69.3	64.2	0.75	4.0	2.3	2.2	6.9	5.9														
0.55	BE 80A	4	1430	3.7	1.38	77.1	73.4	68	0.77	6	2.2	1.9	15	8.2	FD 04	4100	8000	4100	8000	4100	8000	16.6	13.8	10	8000	16.6	13.7	
0.75	BE 80B	4	1430	5	1.76	79.6	78.5	75.1	0.78	6.1	3.2	3	28	12.2	FD 04	4100	7800	4100	7800	4100	7800	22	16.1	15	7800	22	16	
1.1	BE 90S	4	1430	7.4	2.53	81.4	82	79.5	0.76	6.3	2.9	2.8	28	13.6	FD 14	4800	8000	4800	8000	4800	8000	32	17.8	15	8000	32	17.7	
1.5	BE 90LA	4	1430	10	3.5	82.8	83	80	0.74	5.9	3.1	3	34	15.1	FD 05	3400	6000	3400	6000	3400	6000	34	21.1	26	6000	34	21.8	
2.2	BE 100LA	4	1430	14.7	4.9	84.3	85	84	0.76	5.8	3	2.8	54	22	FD 15	2600	4700	2600	4700	2600	4700	44	29	40	4700	44	29	
3	BE 100LB	4	1420	20	6.6	85.5	86	85.5	0.77	5.9	2.8	2.6	61	24	FD 15	2400	4400	2400	4400	2400	4400	58	31	40	4400	58	31	
4	BE 112M	4	1440	27	8.3	86.6	87	86	0.8	6.5	2.8	2.8	105	32	FD 06S	—	1400	—	1400	—	1400	107	42	60	2100	107	44	
5.5	BE 132S	4	1460	36	11.1	88.5	88.5	87.5	0.81	7.3	2.9	2.9	270	53	FD 56	—	1050	—	1050	—	1050	223	66	75	1200	223	67	
7.5	BE 132MA	4	1460	49	14.8	89	89	88.5	0.82	6.9	2.9	2.8	319	59	FD 06	—	950	—	950	—	950	280	72	100	1000	280	77	
9.2	BE 132MB	4	1460	60	18.1	89.5	89.5	88.5	0.82	6.9	2.9	3	360	70	FD 07	—	900	—	900	—	900	342	86	150	900	342	87	
11	BE 160M	4	1465	72	21.5	91	91.3	90.5	0.81	6.5	2.8	2.6	650	99	FD 08	—	800	—	800	—	800	655	129	170	800	655	128	
15	BE 160L	4	1465	98	28.7	90.8	91	90.5	0.83	6.5	2.6	2.3	790	115	FD 08	—	750	—	750	—	750	725	129	200	750	725	128	
18.5	BE 180M	4	1465	121	35	91.6	92	91.3	0.83	6.5	2.6	2.5	1250	135	FD 09	—	400	—	400	—	400	1450	175	—	—	—	—	—
22	BE 180L	4	1465	143	41	91.6	91.8	91.4	0.84	6.8	2.7	2.6	1650	157	FD 09	—	300	—	300	—	300	1850	197	—	—	—	—	—









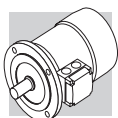

6 P		1000 min <sup>-1</sup> - S1												50 Hz - IE2										
P <sub>n</sub> kW		freno c.c.												freno c.a.										
		FD												FA										
		Mod	M <sub>b</sub> Nm	Z <sub>0</sub> 1/h	NB	SB	J <sub>m</sub> x 10 <sup>-4</sup> kgm <sup>2</sup>	Z <sub>0</sub> 1/h	IM B5  Kg	Mod	M <sub>b</sub> Nm	Z <sub>0</sub> 1/h	J <sub>m</sub> x 10 <sup>-4</sup> kgm <sup>2</sup>	IM B5  Kg										
0.75	BE 90S	6	935	7.7	2.06	75.9	73	0.69	5.1	3.1	2.9	33	15	FD 14	15	3400	6500	28	19.2	FA 14	15	6500	28	19.1
1.1	BE 100M	6 (*)	945	11.1	2.75	78.1	73	0.74	4.9	2.2	1.9	82	22	FD 15	26	2500	4800	58	30	FA 15	26	4800	58	31
1.5	BE 100LA	6	945	15.2	3.9	79.8	74	0.72	5.6	2.5	2.3	95	24	FD 15	40	1900	4100	86	30	FA 15	40	4100	86	31
2.2	BE 112M	6	950	22	5.2	81.8	79.3	0.74	5.2	2.6	2.3	168	32	FD 06S	60	—	2100	177	42	FA 06S	60	2100	177	44
3	BE 132S	6	955	30	6.6	83.3	82.4	0.79	6.1	2.1	1.9	295	44	FD 56	75	—	1400	226	57	FA 06	75	1400	226	58
4	BE 132MA	6	965	40	8.7	84.6	83.1	0.79	6.9	2.2	2	383	56	FD 06	100	—	1200	305	69	FA 07	100	1200	318	74
5.5	BE 160MA	6 (*)	965	54	11.6	87	86.4	0.79	6.6	2.5	2.3	740	83	FD 08	170	—	1000	700	112	FA 08	170	1000	700	113
7.5	BE 160MB	6 (*)	965	74	15	88	87.2	0.82	6.6	2.3	2.1	970	103	FD 08	170	—	900	815	132	FA 08	170	900	815	133





(\*) Relazione potenza/grandezza non unificata







2 P		3000 min <sup>-1</sup> - S1													50 Hz - IE2										
P <sub>n</sub> kW	 BE 80A BE 80B BE 90SA BE 90L BE 112M	n min <sup>-1</sup>	M <sub>n</sub> Nm	I <sub>n</sub> 400V A	η%		cos φ	$\frac{I_s}{I_n}$	$\frac{M_s}{M_n}$	$\frac{M_a}{M_n}$	$J_m \times 10^{-4}$ kgm <sup>2</sup>	IM B5 	freno c.c.						freno c.a.						
					100%	75%							FD			FA									
					M <sub>b</sub> Nm	Z <sub>0</sub> 1/h							NB	SB	M <sub>b</sub> Nm	Z <sub>0</sub> 1/h	IM B5 	J <sub>m</sub> x 10 <sup>-4</sup> kgm <sup>2</sup>	M <sub>b</sub> Nm	Z <sub>0</sub> 1/h	J <sub>m</sub> x 10 <sup>-4</sup> kgm <sup>2</sup>	IM B5 			
0.75	BE 80A	2	2860	2.5	1.65	80	79.6	76.4	0.83	6.8	3.8	3.5	9	9.5	FD 04	5	1700	3200	9.4	12.5	FA 04	5	3200	9.4	12.4
1.1	BE 80B	2	2845	3.7	2.35	81.5	82.2	79.9	0.83	6.9	3.8	3.1	11.4	11.3	FD 04	10	1500	3000	10.6	13.4	FA 04	10	3000	10.6	13.3
1.5	BE 90SA	2	2865	5	3.2	81.3	80.7	78.1	0.82	6.8	3.6	2.8	12.5	12.3	FD 14	15	900	2200	14.1	16.5	FA 14	15	2200	14.1	16.4
2.2	BE 90L	2	2870	7.3	4.7	83.2	83.1	80.8	0.82	6.9	3.1	2.9	16.7	14	FD 05	26	900	2200	21	20	FA 05	26	2200	21	20.7
3.7	BE 112M	2	2930	12.1	7.8	85.5	83	81.2	0.79	7.9	3.5	3.1	57	28	FD 06S	40	—	950	66	39	FA 06S	40	950	66	40



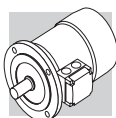

4 P		1500 min <sup>-1</sup> - S1												50 Hz - IE2							
		freno c.c.												freno c.a.							
		FD												FA							
		Mod	M <sub>b</sub>	Z <sub>o</sub>	1/h	NB	SB	J <sub>m</sub>	x 10 <sup>-4</sup>	kgm <sup>2</sup>	IM B5		Mod	M <sub>b</sub>	Z <sub>o</sub>	1/h	J <sub>m</sub>	x 10 <sup>-4</sup>	kgm <sup>2</sup>	IM B5	
P <sub>n</sub>	kW	Mod	M <sub>b</sub>	Z <sub>o</sub>	1/h	NB	SB	J <sub>m</sub>	x 10 <sup>-4</sup>	kgm <sup>2</sup>	IM B5		Mod	M <sub>b</sub>	Z <sub>o</sub>	1/h	J <sub>m</sub>	x 10 <sup>-4</sup>	kgm <sup>2</sup>	IM B5	
0.37	BE 71B	4	1385	2.55	1.05	72.7	69.3	75%	50%	0.75	4.0	2.3	2.2	6.9	5.9	8.6	8	8	8	8.3	8.3
0.55	BE 80A	4	1430	3.7	1.38	77.1	73.4	68	68	0.77	6	2.2	1.9	15	9.9	13.8	16.6	16.6	16.6	13.7	13.7
0.75	BE 80B	4	1430	5	1.76	79.6	78.5	75.1	75.1	0.78	6.1	3.2	3	28	12.2	16.1	22	22	22	16	16
1.1	BE 90S	4	1430	7.4	2.53	81.4	82	79.5	79.5	0.76	6.3	2.9	2.8	28	13.6	17.8	32	32	32	17.7	17.7
1.5	BE 90LA	4	1430	10	3.5	82.8	83	80	80	0.74	5.9	3.1	3	34	15.1	21.1	34	34	34	21.8	21.8
2.2	BE 100LA	4	1430	14.7	4.9	84.3	85	84	84	0.76	5.8	3	2.8	54	22	29	44	44	44	29	29
3.7	BE 112M	4	1445	27	8.2	86.3	87	84.3	84.3	0.76	6.5	2.8	2.8	105	32	42	107	107	107	44	44



6 P		1000 min <sup>-1</sup> - S1										50 Hz - IE2											
P <sub>n</sub> kW		n min <sup>-1</sup>	M <sub>n</sub> Nm	I <sub>n</sub> 400V A	η%		cos φ	$\frac{I_s}{I_n}$	$\frac{M_s}{M_n}$	$\frac{M_a}{M_n}$	J <sub>m</sub> x 10 <sup>-4</sup> kgm <sup>2</sup>	IM B5 	freno c.c.				freno c.a.						
					100%	75%							50%		FD		FA						
					M <sub>b</sub> Nm	Z <sub>0</sub> 1/h							NB	SB	M <sub>b</sub> Nm	Z <sub>0</sub> 1/h	J <sub>m</sub> x 10 <sup>-4</sup> kgm <sup>2</sup>	IM B5 	Mod	M <sub>b</sub> Nm	Z <sub>0</sub> 1/h	J <sub>m</sub> x 10 <sup>-4</sup> kgm <sup>2</sup>	IM B5 
0.75	<b>BE 90S</b>	6	7.7	2.06	75.9	75.9	0.69	5.1	3.1	2.9	33	15	FD 14	15	3400	6500	28	16.8	FA 14	15	6500	28	16.7
1.1	<b>BE 100M</b>	6 (*)	11.1	2.75	78.1	76.2	0.74	4.9	2.2	1.9	82	22	FD 15	40	1900	4100	86	28	FA 15	40	4100	86	29
1.5	<b>BE 100LA</b>	6	15.2	3.9	79.8	77.5	0.72	5.6	2.5	2.3	95	24	FD 15	40	1700	3600	99	30	FA 15	40	3600	99	31
2.2	<b>BE 112M</b>	6	22	5.2	81.8	81.8	0.74	5.2	2.6	2.3	168	32	FD 06S	60	—	2100	177	42	FA 06S	60	2100	177	44
3.7	<b>BE 132MA</b>	6	36.1	8.3	84.3	83.6	0.76	6.9	2.2	2	383	56	FD 06	100	—	1200	305	58	FA 07	100	1200	318	63

(\*) Relazione potenza/grandezza non unificata



4 P		1800 min <sup>-1</sup> - S1										60 Hz - IE2											
P <sub>n</sub>		freno c.c.										freno c.a.											
		FD					FA					FA											
HP	kW	IM B5	J <sub>m</sub> x 10 <sup>-4</sup>	Z <sub>0</sub> 1/h	M <sub>b</sub> Nm	Mod	IM B5	J <sub>m</sub> x 10 <sup>-4</sup>	Z <sub>0</sub> 1/h	M <sub>b</sub> Nm	Mod	IM B5	J <sub>m</sub> x 10 <sup>-4</sup>	Z <sub>0</sub> 1/h	M <sub>b</sub> Nm	Mod	IM B5	J <sub>m</sub> x 10 <sup>-4</sup>	Z <sub>0</sub> 1/h	M <sub>b</sub> Nm	Mod		
0.75	0.55	BE 80A	4	1740	3	1.23	3	1.23	3	1.23	3	1.23	3	1.23	3	1.23	3	1.23	3	1.23	3	1.23	3
1	0.75	BE 80B	4	1745	4.1	1.46	3.2	1.46	4.1	1.46	4.1	1.46	4.1	1.46	4.1	1.46	4.1	1.46	4.1	1.46	4.1	1.46	4.1
1.5	1.1	BE 90S	4	1740	6	2.25	3.2	2.25	6	2.25	6	2.25	6	2.25	6	2.25	6	2.25	6	2.25	6	2.25	6
2	1.5	BE 90LA	4	1740	8.2	3.1	3.4	3.1	8.2	3.1	8.2	3.1	8.2	3.1	8.2	3.1	8.2	3.1	8.2	3.1	8.2	3.1	8.2
3	2.2	BE 100LA	4	1745	12	4.2	2.9	4.2	12	4.2	12	4.2	12	4.2	12	4.2	12	4.2	12	4.2	12	4.2	12
4	3	BE 100LB	4	1735	16.5	5.9	2.9	5.9	16.5	5.9	16.5	5.9	16.5	5.9	16.5	5.9	16.5	5.9	16.5	5.9	16.5	5.9	16.5
5	3.7	BE 112M	4	1750	20	6.6	3.2	6.6	20	6.6	20	6.6	20	6.6	20	6.6	20	6.6	20	6.6	20	6.6	20
7.5	5.5	BE 132S	4	1760	30	9.3	3.5	9.3	30	9.3	30	9.3	30	9.3	30	9.3	30	9.3	30	9.3	30	9.3	30
10	7.5	BE 132MA	4	1760	43	12.7	3.3	12.7	43	12.7	43	12.7	43	12.7	43	12.7	43	12.7	43	12.7	43	12.7	43
12.5	9.2	BE 132MB	4	1760	50	15.6	3.6	15.6	50	15.6	50	15.6	50	15.6	50	15.6	50	15.6	50	15.6	50	15.6	50
15	11	BE 160M	4	1765	60	18.7	2.8	18.7	60	18.7	60	18.7	60	18.7	60	18.7	60	18.7	60	18.7	60	18.7	60
20	15	BE 160L	4	1770	81	25.5	2.7	25.5	81	25.5	81	25.5	81	25.5	81	25.5	81	25.5	81	25.5	81	25.5	81
25	18.5	BE 180M	4	1765	100	30.3	2.5	30.3	100	30.3	100	30.3	100	30.3	100	30.3	100	30.3	100	30.3	100	30.3	100
30	22	BE 180L	4	1770	119	36	3.2	36	119	36	119	36	119	36	119	36	119	36	119	36	119	36	119



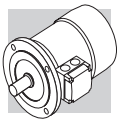



2 P		3000 min <sup>-1</sup> - S1												50 Hz - IE2					
		freno c.c.												freno c.a.					
		FD						FA											
P <sub>n</sub>	kW	In	M <sub>n</sub>	n	M <sub>s</sub>	M <sub>a</sub>	J <sub>m</sub>	IM B5	Mod	M <sub>b</sub>	Z <sub>0</sub>	Z <sub>0</sub>	J <sub>m</sub>	IM B5	Mod	M <sub>b</sub>	Z <sub>0</sub>	J <sub>m</sub>	IM B5
		400V	Nm	min <sup>-1</sup>	$\frac{M_s}{M_n}$	$\frac{M_a}{M_n}$	x 10 <sup>-4</sup> kgm <sup>2</sup>	Kg		Nm	1/h	1/h	x 10 <sup>-4</sup> kgm <sup>2</sup>	Kg		Nm	1/h	x 10 <sup>-4</sup> kgm <sup>2</sup>	Kg
		A	Nm								NB	SB							
0.75	ME 2SA	2	2.5	2860	3.8	3.5	9	8.8	FD 04	5	1700	3200	9.4	12.7	FA 04	5	3200	9.4	12.6
1.1	ME 2SB	2	3.7	2845	3.8	3.1	11.4	10.6	FD 04	10	1500	3000	13	14.5	FA 04	10	3000	13	14.4
1.5	ME 3SA	2	5.0	2845	2.9	2.7	24	15.5	FD 15	13	1300	2600	22	22	FA 15	26	2600	22	23
2.2	ME 3LA	2	7.3	2895	2.7	2.5	31	18.7	FD 15	26	1100	2400	28	25.2	FA 15	26	2400	28	26.2
3	ME 3LB	2	9.9	2880	3.5	3.1	39	22	FD 15	26	700	1600	35	28.5	FA 15	26	1600	35	29.5
4	ME 4SA	2	13.2	2900	2.9	2.8	101	33	FD 06	50	—	1400	107	46	FA 06	50	2100	107	47
5.5	ME 4SB	2	18.0	2925	3.6	3.3	145	40	FD 06	50	—	600	112	48	FA 06	50	600	112	49
7.5	ME 4LA	2	24	2935	3.9	3.6	178	51	FD 06	50	—	550	154	55	FA 06	50	550	154	56
9.2	ME 4LB	2	30	2920	3.7	3.3	210	60	FD 56	75	—	430	189	66	FA 06	75	430	189	67
11	ME 5SA	2	36	2940	3.0	2.9	340	70											
15	ME 5SB	2	49	2950	3.0	2.8	420	83											
18.5	ME 5LA	2	60	2945	2.9	2.7	490	95											



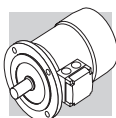

4 P		1500 min <sup>-1</sup> - S1												50 Hz - IE2														
P <sub>n</sub> kW	CE A068744	n min <sup>-1</sup>	M <sub>n</sub> Nm	I <sub>n</sub> 400V A	η%			cos φ	I <sub>s</sub> I <sub>n</sub>	M <sub>s</sub> M <sub>n</sub>	M <sub>a</sub> M <sub>n</sub>	J <sub>m</sub> x 10 <sup>-4</sup> kgm <sup>2</sup>	IM B5 Kg	freno c.c.				freno c.a.										
					100%	75%	50%							Mod	M <sub>b</sub> Nm	Z <sub>0</sub> 1/h	NB	SB	Mod	M <sub>b</sub> Nm	Z <sub>0</sub> 1/h	J <sub>m</sub> x 10 <sup>-4</sup> kgm <sup>2</sup>	IM B5 Kg					
					In	η%	η%																	FD	FA			
0.12	ME 05A	4	0.84	0.45	59.1	59.6	53.5	0.65	3	2	2.2	2.3	3.5	FD 02	1.75	10000	—	—	FD 02	1.75	13000	—	—	FA 02	1.75	13000	2.6	5.2
0.18	ME 05B	4	1.25	0.64	64.7	65.1	59.8	0.62	3.5	2.3	2.5	3.3	5.1	FD 02	3.5	10000	—	—	FD 02	3.5	13000	—	—	FA 02	3.5	13000	3	5.6
0.25	ME 1SA	4	1.73	0.68	68.5	68	62	0.78	4	2.3	2.5	5.8	5.1	FD 03	3.5	7700	—	—	FD 03	3.5	11000	—	—	FA 03	3.5	11000	6.9	7.8
0.37	ME 1SB	4	2.55	1.05	72.7	69.3	64.2	0.75	4.0	2.3	2.2	6.9	5.9	FD 03	5	6000	—	—	FD 03	5	9400	—	—	FA 03	5	9400	8.0	8.6
0.55	ME 2SA	4	3.7	1.38	77.1	73.4	68	0.77	6	2.2	1.9	15	9.9	FD 04	10	4100	—	—	FD 04	10	8000	—	—	FA 04	10	8000	16.6	13.8
0.75	ME 2SB	4	5	1.76	79.6	78.5	75.1	0.78	6.1	3.2	3.0	28	12.2	FD 04	15	4100	—	—	FD 04	15	7800	—	—	FA 04	15	7800	22	16.1
1.1	ME 3SA	4	7.4	2.53	82.5	82.0	79.5	0.76	6.3	2.9	2.8	28	15.5	FD 15	26	4800	—	—	FD 15	26	8000	—	—	FA 15	26	8000	32	21.5
1.5	ME 3SB	4	10	3.5	83.5	83.0	80.0	0.74	5.9	3.1	3.0	34	17	FD 15	26	3400	—	—	FD 15	26	6000	—	—	FA 15	26	6000	34	23
2.2	ME 3LA	4	14.7	4.9	84.3	85	84	0.76	5.8	3	2.8	54	21	FD 15	40	2600	—	—	FD 15	40	4700	—	—	FA 15	40	4700	44	27
3	ME 3LB	4	20	6.6	85.5	86.0	85.5	0.77	5.9	2.8	2.6	61	23	FD 15	40	2400	—	—	FD 15	40	4400	—	—	FA 15	40	4400	58	29
4	ME 4SA	4	27	8.3	87.0	87.0	86.0	0.80	6.5	2.8	2.8	105	42	FD 56	75	—	—	FD 56	75	1400	—	—	FA 06	75	2100	107	55	
5.5	ME 4SB	4	36	11.1	88.5	88.5	87.5	0.81	7.3	2.9	2.9	270	51	FD 56	75	—	—	FD 56	75	1050	—	—	FA 06	75	1200	223	64	
7.5	ME 4LA	4	49	14.8	89.0	89.0	88.5	0.82	6.9	2.9	2.8	319	57	FD 06	100	—	—	FD 06	100	950	—	—	FA 07	100	1000	280	70	
9.2	ME 4LB	4	60	18.1	89.5	89.5	88.5	0.82	6.9	2.9	3.0	360	65	FD 07	150	—	—	FD 07	150	900	—	—	FA 07	150	900	342	81	
11	ME 5SA	4	72	21.5	91.0	91.3	90.5	0.81	6.5	2.8	2.6	650	85	FD 08	170	—	—	FD 08	170	800	—	—	FA 08	170	800	655	115	
15	ME 5LA	4	98	28.7	90.8	91.0	90.5	0.83	6.5	2.6	2.3	790	101	FD 08	200	—	—	FD 08	200	750	—	—	FA 08	200	750	710	131	



6 P		1000 min <sup>-1</sup> - S1												50 Hz - IE2																
  A068744		freno c.c.												freno c.a.																
		FD												FA																
		P <sub>n</sub>	n	M <sub>n</sub>	In	100%	75%	50%	cos φ	I <sub>s</sub>	I <sub>n</sub>	M <sub>s</sub>	M <sub>n</sub>	M <sub>a</sub>	M <sub>n</sub>	J <sub>m</sub>	IM B5	Mod	M <sub>b</sub>	Z <sub>0</sub>	NB	SB	Z <sub>0</sub>	1/h	J <sub>m</sub>	IM B5	Mod	M <sub>b</sub>	Z <sub>0</sub>	1/h
kW	min <sup>-1</sup>	Nm	A	100%	75%	50%		A				kgm <sup>2</sup>	kg	kgm <sup>2</sup>	kg		Nm	1/h			1/h	kgm <sup>2</sup>	kg		Nm	1/h	kgm <sup>2</sup>	kg		
0.75	ME 3SA	6	940	7.6	1.98	75.9	75.0	70.7	0.72	4.7	2.2	2	33	17	FD 15	26	3400	6500	—	—	2100	6500	28	21	FA 15	26	6500	28	22	
1.1	ME 3LA	6 (*)	945	11.1	2.75	78.1	76.2	73.0	0.74	4.9	2.2	1.9	82	21	FD 15	26	2700	5000	—	—	1400	5000	37	27	FA 15	26	5000	37	28	
1.5	ME 3LB	6	945	15.2	3.8	79.8	77.5	74.0	0.72	5.6	2.5	2.3	95	23	FD 15	40	1900	4100	—	—	1200	4100	86	29	FA 15	40	4100	86	30	
2.2	ME 4SA	6	955	22	4.9	81.8	81.8	80.0	0.80	5.7	1.9	1.7	216	34	FD 06	50	—	2100	—	—	2100	2100	177	47	FA 06	50	2100	177	48	
3	ME 4SB	6	955	30	6.6	83.3	83.3	82.4	0.79	6.1	2.1	1.9	295	43	FD 56	75	—	1400	—	—	1400	1400	226	56	FA 06	75	1400	226	57	
4	ME 4LA	6	965	40	8.6	84.6	85.0	83.1	0.79	6.9	2.2	2.0	383	54	FD 06	100	—	1200	—	—	1200	305	70	FA 07	100	1200	305	72		
5.5	ME 5SA	6 (*)	965	54	11.6	87.0	87.0	86.4	0.79	6.6	2.5	2.3	740	69	FD 08	170	—	1050	—	—	1050	406	99	FA 08	170	1050	406	98		
7.5	ME 5SB	6 (*)	965	74	15.0	88.0	88.0	87.2	0.82	6.6	2.3	2.1	970	89	FD 08	170	—	900	—	—	900	815	119	FA 08	170	900	815	118		

(\*) Relazione potenza/grandezza non unificata









<b>2 P</b>	<b>3000 min<sup>-1</sup> - S1</b>	<b>50 Hz - IE2</b>
------------	-----------------------------------	--------------------

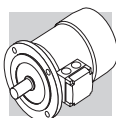

P <sub>n</sub> kW	n min <sup>-1</sup>	M <sub>n</sub> Nm	I <sub>n</sub> 400V A	η%		cos φ	I <sub>s</sub> I <sub>n</sub>	M <sub>s</sub> M <sub>n</sub>	M <sub>a</sub> M <sub>n</sub>	J <sub>m</sub> x 10 <sup>-4</sup> kgm <sup>2</sup>	IM B5 Kg	freno c.c.										
				100%	75%							FD		FA								
				80	79.6							76.4	50%	Mod	M <sub>b</sub> Nm	Z <sub>0</sub> 1/h	NB	SB	J <sub>m</sub> x 10 <sup>-4</sup> kgm <sup>2</sup>	IM B5 Kg	Mod	M <sub>b</sub> Nm
0.75	2860	2.5	1.63	80	79.6	0.83	6.8	3.8	3.5	9	8.8	FD 04	5	1700	3200	9.4	12.7	FA 04	5	3200	9.4	12.6
1.1	2845	3.7	2.35	81.5	82.2	0.83	6.9	3.8	3.1	11.4	10.6	FD 04	10	1500	3000	10.6	14.5	FA 04	10	3000	10.6	14.4
1.5	2845	5	3.2	81.3	79	0.81	6.1	2.9	2.7	24	15.5	FD 15	13	4800	8000	32	22.5	FA 15	26	8000	32	22.5
2.2	2895	7.3	4.7	83.2	83.1	0.82	6.9	3.1	2.9	16.7	18.7	FD 15	26	3400	6000	34	25.7	FA 15	26	6000	34	25.7
3.7	2930	12.1	7.8	84.7	83	0.79	7.9	3.5	3.1	57	33	FD 56	75	—	1400	107	46	FA 06	75	2100	107	47



4 P		1500 min <sup>-1</sup> - S1											50 Hz - IE2									
P <sub>n</sub> kW	 n min <sup>-1</sup>	M <sub>n</sub> Nm	I <sub>n</sub> 400V A	η%		cos φ	$\frac{I_s}{I_n}$	$\frac{M_s}{M_n}$	$\frac{M_a}{M_n}$	$J_m \times 10^{-4}$ kgm <sup>2</sup>	IM B5 	freno c.c.						freno c.a.				
				100%	75%							FD		FA								
				100%	75%							Mod	M <sub>b</sub> Nm	Z <sub>o</sub> 1/h	NB	SB	J <sub>m</sub> x 10 <sup>-4</sup> kgm <sup>2</sup>	IM B5 	Mod	M <sub>b</sub> Nm	Z <sub>o</sub> 1/h	J <sub>m</sub> x 10 <sup>-4</sup> kgm <sup>2</sup>
0.37	<b>ME 1SB</b> 4	2.55	1.05	72.7	69.3	0.75	4.0	2.3	2.2	6.9	5.9	FD 03	5	6000	9400	8	8.6	FA 03	5	9400	8	8.3
0.55	<b>ME 2SA</b> 4	3.7	1.38	77.1	73.4	0.77	6	2.2	1.9	15	9.9	FD 04	10	4100	8000	16.6	13.8	FA 04	10	8000	16.6	13.7
0.75	<b>ME 2SB</b> 4	5	1.76	79.6	78.5	0.78	6.1	3.2	3	28	12.2	FD 04	15	4100	7800	22	16.1	FA 04	15	7800	22	16
1.1	<b>ME 3SA</b> 4	7.4	2.6	82.5	82	0.74	5.5	2.5	2.8	34	15.5	FD 15	26	4800	8000	32	22.5	FA 15	26	8000	32	22.5
1.5	<b>ME 3SB</b> 4	10.1	3.48	84	84	0.74	6.2	2.9	2.9	40	17	FD 15	26	3400	6000	34	24	FA 15	26	6000	34	24
2.2	<b>ME 3LA</b> 4	14.7	4.9	84.3	85	0.76	5.8	3	2.8	54	21	FD 15	40	2600	4700	44	28	FA 15	40	4700	44	28
3.7	<b>ME 4SA</b> 4	27	8.25	87.5	86.8	0.80	7.1	3	3.1	213	42	FD 56	75	—	1400	107	55	FA 06	75	2100	107	56



6 P		1000 min <sup>-1</sup> - S1										50 Hz - IE2											
P <sub>n</sub> kW	 IM B5 Kg	n min <sup>-1</sup>	M <sub>n</sub> Nm	I <sub>n</sub> 400V A	η%		cos φ	$\frac{I_s}{I_n}$	$\frac{M_s}{M_n}$	$\frac{M_a}{M_n}$	$J_m \times 10^{-4}$ kgm <sup>2</sup>	IM B5 Kg	freno c.c.				freno c.a.						
					100%	75%							FD		FA								
					100%	75%							M <sub>b</sub> Nm	Z <sub>0</sub> 1/h	NB	SB	M <sub>b</sub> Nm	Z <sub>0</sub> 1/h	J <sub>m</sub> x 10 <sup>-4</sup> kgm <sup>2</sup>	IM B5 Kg	Mod	M <sub>b</sub> Nm	Z <sub>0</sub> 1/h
0.75	ME 3SA	6	7.6	1.98	75.9	75	0.72	4.7	2.2	2	33	17	FD 15	26	3400	6500	28	21	FA 15	26	6500	28	22
1.1	ME 3LA	6 (*)	11.1	2.75	78.1	76.2	0.74	4.9	2.2	1.9	82	21	FD 15	26	2700	5000	37	27	FA 15	26	5000	37	28
1.5	ME 3LB	6	15.2	3.8	79.8	77.5	0.72	5.6	2.5	2.3	95	23	FD 15	40	1900	4100	86	29	FA 15	40	4100	86	30
2.2	ME 4SA	6	22	4.9	81.8	81.8	0.8	5.7	1.9	1.7	216	34	FD 56	75	—	2100	177	47	FA 06	60	2100	177	48
3.7	ME 4LA	6	36.1	8.3	83.5	83.6	0.76	6.9	2.2	2	383	54	FD 06	100	—	1200	305	70	FA 06	100	1200	305	72

(\*) Relazione potenza/grandezza non unificata





M19 DIMENSIONI MOTORI BE-ME

**BE - IM B5- CE/CUS/BIS/CCC**

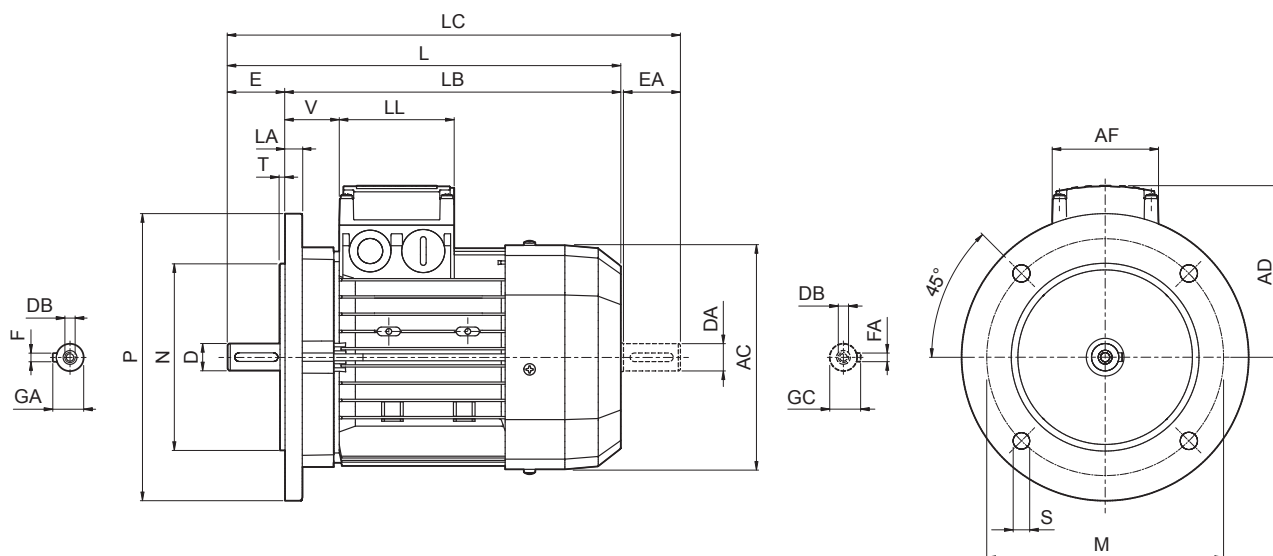

**BE-ME**

	Albero					Flangia						Motore							
	D DA	E EA	DB	GA GC	F FA	M	N	P	S	T	LA	AC	L	LB	LC	AD	AF	LL	V
BE 63	11	23	M4	12.5	4	115	95	140	9.5	3	10	121	207	184	232	95	74	80	26
BE 71	14	30	M5	16	5	130	110	160				138	249	219	281	108			
BE 80	19	40	M6	21.5	6	165	130	200	11.5	3.5	11.5	156	274	234	315	119	98	98	38
BE 90 S	24	50	M8	27	8							176	326	276	378	133			
BE 90 L						50	110	160	11.5	3.5	11.5	176	326	276	378	133	98	98	44
BE 100	28	60	M10	31	8	215	180	250	14	4	14	195	367	307	429	142	98	98	50
BE 112												219	385	325	448	157			
BE 132 S	38	80	M12	41	10	265	230	300	14	4	20	258	493	413	576	193	118	118	58
BE 132 MA													528	448	611				
BE 132 MB													528	448	611				
BE 160 M	42 38 <sup>(1)</sup>	110 80 <sup>(1)</sup>	M16 M12 <sup>(1)</sup>	45 41 <sup>(1)</sup>	12 10 <sup>(1)</sup>	300	250	350	18.5	5	15	310	596	486	680	245	187	187	51
BE 160 L													640	530	724				
BE 180 M	48 42 <sup>(1)</sup>	110 110 <sup>(1)</sup>	M16 M16 <sup>(1)</sup>	51.5 45 <sup>(1)</sup>	14 12 <sup>(1)</sup>	300	250	350	18.5	5	18	348	708	598	823	261	187	187	52
BE 180 L													708	598	823	261			

N.B.:

1) Queste dimensioni sono riferite alla seconda estremità d'albero (PS).



# BE - IM B14- CE/CUS/BIS/CCC

**BE-IME**

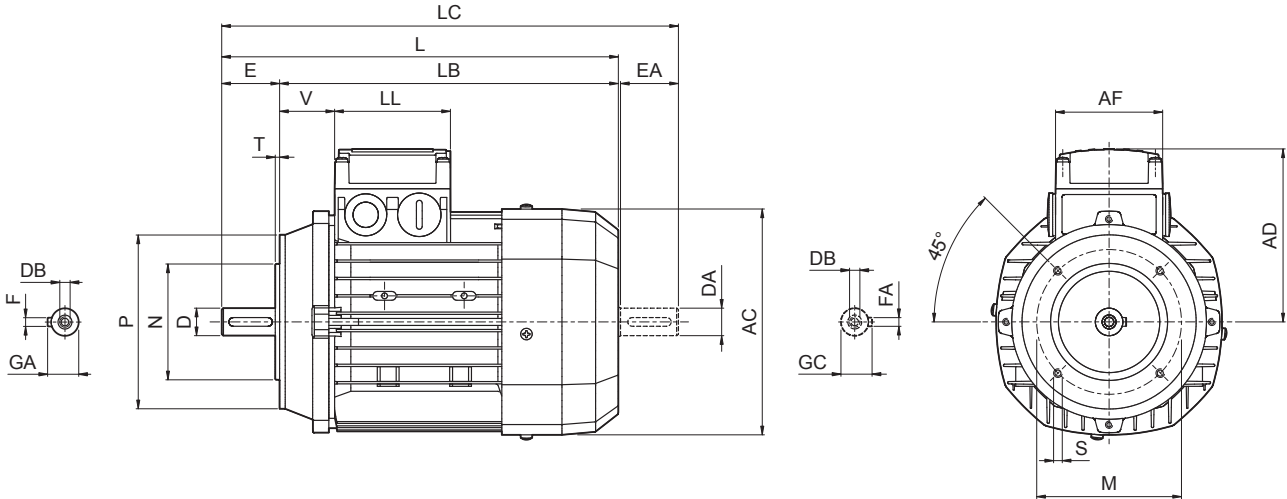

	Albero					Flangia					Motore								
	D DA	E EA	DB	GA GC	F FA	M	N	P	S	T	AC	L	LB	LC	AD	AF	LL	V	
<b>BE 63</b>	11	23	M4	12.5	4	75	60	90	M5	2.5	121	207	184	232	95	74	80	37	
<b>BE 71</b>	14	30	M5	16	5	85	70	105	M6	3	138	249	219	281	108			98	98
<b>BE 80</b>	19	40	M6	21.5	6	100	80	120			M8	3.5	156	274	234	315	119		
<b>BE 90 S</b>	24	50	M8	27	8	115	95	140	M10	4			176	326	276	378	133	193	118
<b>BE 90 L</b>						130	110	160			258	493	413	576	58				
<b>BE 100</b>	28	60	M10	31	10	130	110	160	M10	4	195	367	307	429	142	193	118	118	52
<b>BE 112</b>						219	385	325			448	157	528	448	611				58
<b>BE 132 S</b>	38	80	M12	41	10	165	130	200	M10	4	258	493	413	576	193	118	118	58	
<b>BE 132 MA</b>						528	448	611			58								
<b>BE 132 MB</b>						528	448	611			58								



# BE - IM B5 - FD/FA - CE/CUS/BIS

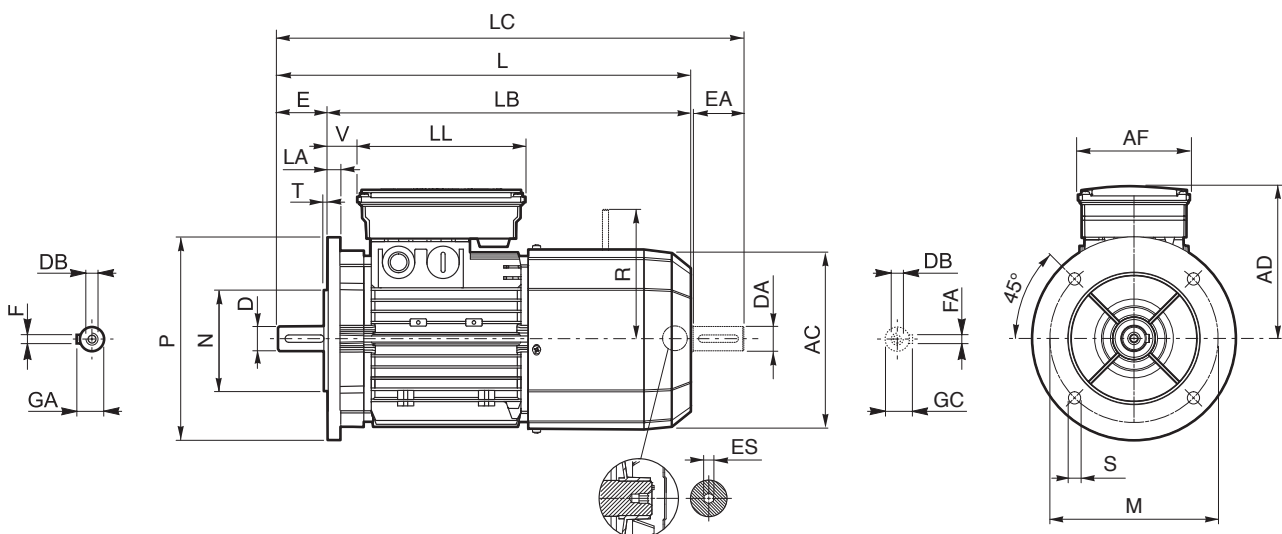

	Albero					Flangia						Motore										
	D DA	E EA	DB	GA GC	F FA	M	N	P	S	T	LA	AC	L	LB	LC	AD	AF	LL	V	R		ES <sup>(2)</sup>
																				FD	FA	
BE 63	11	23	M4	12.5	4	115	95	140	9.5	3	10	121	272	249	297	122	98	133	14	96	116	5
BE 71	14	30	M5	16	5	130	110	160		10		138	313	283	345	135			24	103	124	
BE 80	19	40	M6	21.5	6	165	130	200	11.5	3.5	11.5	156	348	308	390	143	110	165	25	129	134	6
BE 90 S	24	50	M8	27	8							176	411	361	463	146			32	160	160	
BE 90 L						37	199	198														
BE 100	28	60	M10	31	8	215	180	250	14	4	20	195	458	398	521	155	140	188	39	199	198	6
BE 112												15	219	484	424	547			170	204	200	
BE 132 S	38	80	M12	41	10	265	230	300	14	4	20	258	603	523	686	193	140	188	46	204	200	—
BE 132 MA													628	548	711					226	217	
BE 132 MB													736	626	820					245	51	
BE 160 M	42	110	M16	45	12	300	250	350	18.5	5	15	310	780	670	864	187	187	52	305	—		
BE 160 L													38 <sup>(1)</sup>	80 <sup>(1)</sup>	M12 <sup>(1)</sup>						41 <sup>(1)</sup>	10 <sup>(1)</sup>
BE 180 M	48	110	M16	51.5	14	300	250	350	18.5	5	18	348	866	756	981	261	52	305	—			
BE 180 L													42 <sup>(1)</sup>	110 <sup>(1)</sup>	M16 <sup>(1)</sup>	45 <sup>(1)</sup>	12 <sup>(1)</sup>					

N.B.: 1) Queste dimensioni sono riferite alla seconda estremità d'albero (PS). 2) L'esagono ES non è presente con l'opzione PS.



# BE - IM B14 - FD/FA - CE/CUS/BIS

**BE-IME**

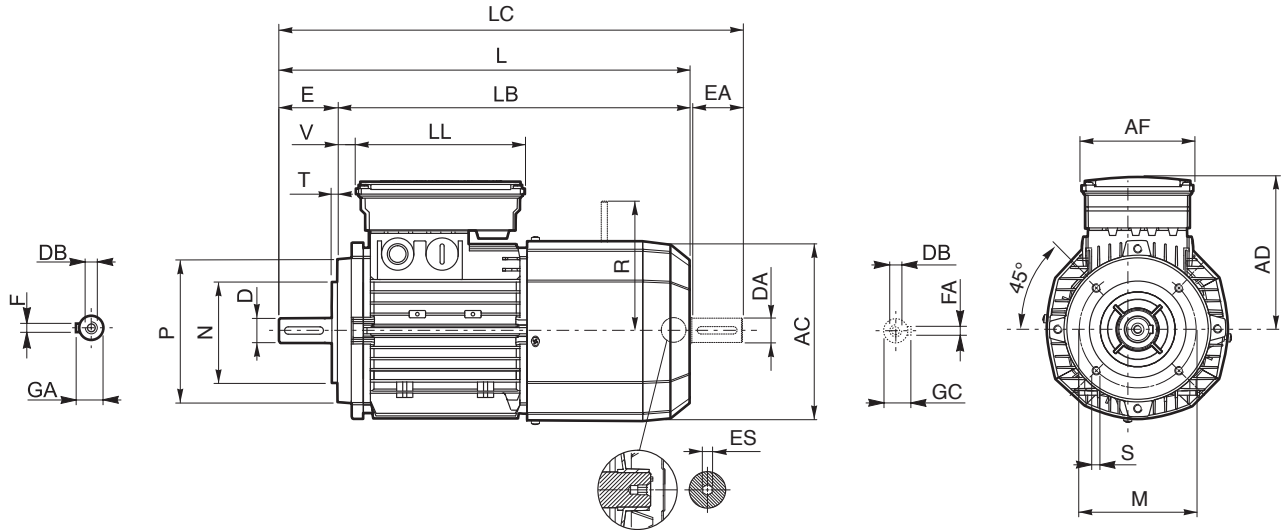

	Albero					Flangia					Motore										
	D DA	E EA	DB	GA GC	F FA	M	N	P	S	T	AC	L	LB	LC	AD	AF	LL	V	R		ES <sup>(2)</sup>
																			FD	FA	
<b>BE 63</b>	11	23	M4	12.5	4	75	60	90	M5	2.5	121	272	249	297	122			14	96	116	
<b>BE 71</b>	14	30	M5	16	5	85	70	105	M6	3	138	313	283	345	135	98	133	24	103	124	5
<b>BE 80</b>	19	40	M6	21.5	6	100	80	120			156	348	308	390	143			25	129	134	
<b>BE 90 S</b>	24	50	M8	27	8	115	95	140	M8	3.5	176	411	361	463	146	110	165	32	160	160	6
<b>BE 90 L</b>																					
<b>BE 100</b>	28	60	M10	31	130	110	160	M8	3.5	195	458	398	521	155	110	165	32	160	160	6	
<b>BE 112</b>																					37
<b>BE 132 S</b>	38	80	M12	41	10	165	130	200	M10	4	258	603	523	686	193	140	188	46	204	200	6
<b>BE 132 MA</b>																					
<b>BE 132 MB</b>												226	217	—							

N.B.: 2) L'esagono ES non è presente con l'opzione PS.





**ME - CE/CUS/BIS/CCC**

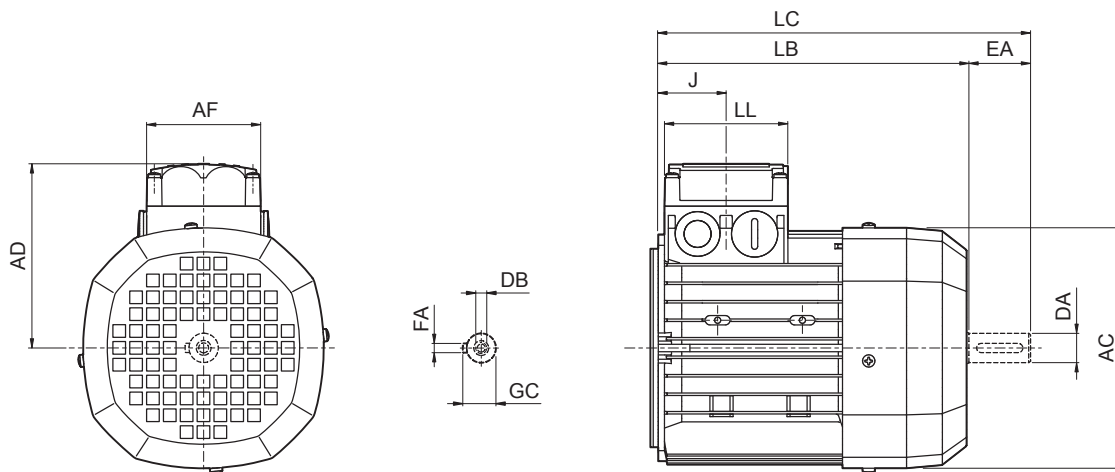

**BE-ME**

	Seconda estremità albero					Motore						
	DA	EA	DB	FA	GC	AC	LB	LC	AF	LL	J	AD
ME 05	11	23	M4	12.5	4	121	165	191	74	80	48	95
ME 1S	14	30	M5	16	5	138	187	219			45	108
ME 2S	19	40	M6	21.5	6	156	202	245			44	119
ME 3S	28	60	M10	31	8	195	230	293	98	98	53.5	142
ME 3L							262	325				
ME 4S	38	80	M12	41	10	258	361	444	118	118	64.5	193
ME 4L							396	479				
ME 4LB												
ME 5S	38	80	M12	41	10	310	418	502	187	187	77	245
ME 5L							462	546				



# ME\_FD/FA - CE/CUS/BIS

**BE-ME**

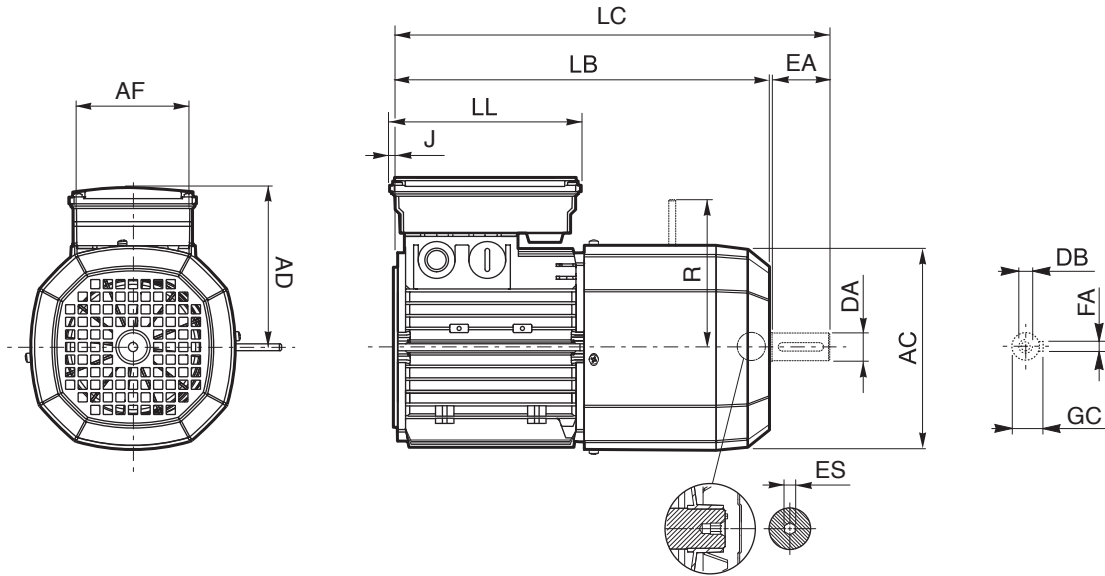

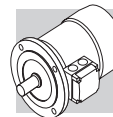

	Seconda estremità albero					Motore										
	DA	EA	DB	GC	FA	AC	LB	LC	AF	LL	J	AD	R FD FA		ES <sup>(1)</sup>	
<b>ME 05</b>	11	23	M4	12.5	4	121	231	256			-4.5	119	96	116	5	
<b>ME 1S</b>	14	30	M5	16	5	138	248	280	98	133	-8	135	103	124		
<b>ME 2S</b>	19	40	M6	21.5	6	156	272	314			-17	143	129	134		
<b>ME 3S</b>	28	60	M10	31	8	195	326	389	110	165	7	155	160	160	6	
<b>ME 3L</b>							353	416								
<b>ME 4S</b>	38	80	M12	41	10	258	470	553	140	188	7	210	204	200		
<b>ME 4LA</b>							495	578					226	217		
<b>ME 4LB</b>																
<b>ME 5S</b>	38	80	M12	41	10	310	558	642	187	187	17	245	266	247		---
<b>ME 5L</b>							602	686								

N.B.: 1) L'esagono ES non è presente con l'opzione PS.





M20 DATI TECNICI MOTORI BN-M

2P		3000 min <sup>-1</sup> - S1														50 Hz											
		freno c.c.														freno c.a.											
		P <sub>n</sub> kW		n min <sup>-1</sup>	M <sub>n</sub> Nm	IE1	η (100%) %	η (75%) %	η (50%) %	cosφ	In 400V A	Is In	Ms Min	Ma Min	J <sub>m</sub> x 10 <sup>-4</sup> kgm <sup>2</sup>	IM B5  Kg	Mod	Mb Nm	Z <sub>0</sub> 1/h	NB	SB	J <sub>m</sub> x 10 <sup>-4</sup> kgm <sup>2</sup>	IM B5  Kg	Mod	Mb Nm	Z <sub>0</sub> 1/h	J <sub>m</sub> x 10 <sup>-4</sup> kgm <sup>2</sup>
FD	FA																										
0.18	BN 63A	2	2730	0.63	○	59.9	56.9	51.9	0.77	0.56	3.0	2.1	2.0	2.0	3.5	FD 02	1.75	3900	4800	4800	2.6	5.2	FA 02	1.75	4800	2.6	5.0
0.25	BN 63B	2	2740	0.87	○	66.0	64.8	64.8	0.76	0.72	3.3	2.3	2.3	2.3	3.9	FD 02	1.75	3900	4800	4800	3.0	5.6	FA 02	1.75	4800	3.0	5.4
0.37	BN 63C	2	2800	1.26	○	69.1	66.8	66.8	0.78	0.99	3.9	2.6	2.6	3.3	5.1	FD 02	3.5	3600	4500	4500	3.9	6.8	FA 02	3.5	4500	3.9	6.6
0.37	BN 71A	2	2820	1.25	○	73.8	73.0	70.6	0.76	0.95	4.8	2.8	2.6	3.5	5.4	FD 03	3.5	3000	4100	4100	4.6	8.1	FA 03	3.5	4200	4.6	7.8
0.55	BN 71B	2	2820	1.86	○	76.0	75.8	74.8	0.76	1.37	5.0	2.9	2.8	4.1	6.2	FD 03	5	2900	4200	4200	5.3	8.9	FA 03	5	4200	5.3	8.6
0.75	BN 71C	2	2810	2.6	○	76.6	76.2	76.2	0.76	1.86	5.1	3.1	2.8	5.0	7.3	FD 03	5	1900	3300	3300	6.1	10.0	FA 03	5	3600	6.1	9.7
0.75	BN 80A	2	2810	2.6	●	76.2	75.5	68.3	0.81	1.75	4.8	2.6	2.2	7.8	8.6	FD 04	5	1700	3200	3200	9.4	12.5	FA 04	5	3200	9.4	12.4
1.1	BN 80B	2	2800	3.8	●	76.4	76.2	75.0	0.81	2.57	4.8	2.8	2.4	9.0	9.5	FD 04	10	1500	3000	3000	10.6	13.4	FA 04	10	3000	10.6	13.3
1.5	BN 80C	2	2800	5.1	●	79.1	79.5	77.2	0.81	3.4	4.9	2.7	2.4	11.4	11.3	FD 04	15	1300	2600	2600	13.0	15.2	FA 04	15	2600	13.0	15.1
1.5	BN 90SA	2	2870	5.0	●	82.0	81.5	78.1	0.80	3.4	5.9	2.7	2.6	12.5	12.3	FD 14	15	900	2200	2200	14.1	16.5	FA 14	15	2200	14.1	16.4
1.85	BN 90SB	2	2880	6.1	●	82.5	82.0	75.4	0.80	4.0	6.2	2.9	2.6	16.7	14	FD 14	15	900	2200	2200	18.3	18.2	FA 14	15	2200	18.3	18.1
2.2	BN 90L	2	2880	7.3	●	82.7	82.1	80.8	0.80	4.8	6.3	2.9	2.7	16.7	14	FD 05	26	900	2200	2200	21	20	FA 05	26	2200	21	20.7
3	BN 100L	2	2860	10.0	●	81.5	81.3	77.4	0.79	6.7	5.6	2.6	2.2	31	20	FD 15	26	700	1600	1600	35	26	FA 15	26	1600	35	27
4	BN 100LB	2	2870	13.3	●	83.1	83.0	77.8	0.80	8.7	5.8	2.7	2.5	39	23	FD 15	40	450	900	900	43	29	FA 15	40	1000	43	30
4	BN 112M	2	2900	13.2	●	85.5	84.5	83.0	0.82	8.2	6.9	3.0	2.9	57	28	FD 06S	40	—	950	950	66	39	FA 06S	40	950	66	40
5.5	BN 132SA	2	2890	18.2	●	84.7	84.5	81.2	0.84	11.2	5.9	2.6	2.2	101	35	FD 06	50	—	600	600	112	48	FA 06	50	600	112	49
7.5	BN 132SB	2	2900	25	●	86.5	86.3	84.4	0.85	14.7	6.4	2.6	2.2	145	42	FD 06	50	—	550	550	154	55	FA 06	50	550	154	56
9.2	BN 132M	2	2930	30	●	87.0	86.5	83.6	0.86	17.7	6.7	2.8	2.3	178	53	FD 06	75	—	430	430	189	66	FA 06	75	430	189	67
11	BN 160MR	2	2920	36	●	87.6	87.0	86.0	0.88	20.6	6.9	2.9	2.5	210	65	FD 06	50	—	600	600	112	48	FA 06	50	600	112	49
15	BN 160MB	2	2930	49	●	89.6	89.4	88.0	0.86	28.1	7.1	2.6	2.3	340	84	FD 06	50	—	550	550	154	55	FA 06	50	550	154	56
18.5	BN 160L	2	2930	60	●	90.4	90.1	89.0	0.86	34	7.6	2.7	2.3	420	97	FD 06	75	—	430	430	189	66	FA 06	75	430	189	67
22	BN 180M	2	2930	72	●	89.9	89.7	89.5	0.88	40	7.8	2.6	2.4	490	109	FD 06	75	—	430	430	189	66	FA 06	75	430	189	67
30	BN 200LA	2	2930	98	●	90.7	90.1	87.6	0.89	54	7.8	2.7	2.9	770	140	FD 06	75	—	430	430	189	66	FA 06	75	430	189	67

○ = n.a. ● = IE1

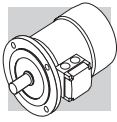
BN-M







4P		1500 min <sup>-1</sup> - S1										50 Hz													
		freno c.c.										freno c.a.													
P <sub>n</sub> kW		n min <sup>-1</sup>	M <sub>n</sub> Nm	IE1	η (100%) %	η (75%) %	η (50%) %	cosφ	In 400V A	Is In %	Ms Mn %	Ma Mn %	J <sub>m</sub> x 10 <sup>-4</sup> kgm <sup>2</sup>	IM B5 Kg	Mod	Mb Nm	Z <sub>0</sub> 1/h	SB	J <sub>m</sub> x 10 <sup>-4</sup> kgm <sup>2</sup>	IM B5 Kg	FA				
																					Mod	Mb	Z <sub>0</sub>	J <sub>m</sub> x 10 <sup>-4</sup> kgm <sup>2</sup>	IM B5 Kg
0.06	BN 56A	4	0.43	○	46.8	44.2	41.3	0.65	0.28	2.6	2.3	2.0	1.5	3.1											
0.09	BN 56B	4	0.64	○	51.7	47.6	42.9	0.60	0.42	2.6	2.5	2.4	1.5	3.1											
0.12	BN 63A	4	0.85	○	59.8	56.2	47.0	0.62	0.47	2.6	1.9	1.8	2.0	3.5	FD 02	1.75	10000	13000	2.6	5.2	FA 02	1.75	13000	2.6	5.0
0.18	BN 63B	4	1.30	○	54.8	52.9	52.5	0.67	0.71	2.6	2.2	2.0	2.3	3.9	FD 02	3.5	10000	13000	3.0	5.6	FA 02	3.5	13000	3.0	5.4
0.25	BN 63C	4	1.78	○	65.3	65.0	57.9	0.69	0.80	2.7	2.1	1.9	3.3	5.1	FD 02	3.5	7800	10000	3.9	6.8	FA 02	3.5	10000	3.9	6.6
0.25	BN 71A	4	1.73	○	63.7	62.2	59.1	0.73	0.78	3.3	1.9	1.7	5.8	5.1	FD 03	3.5	7700	11000	6.9	7.8	FA 03	3.5	11000	6.9	7.5
0.37	BN 71B	4	2.6	○	66.8	66.7	63.0	0.76	1.05	3.7	2.0	1.9	6.9	5.9	FD 03	5	6000	9400	8.0	8.6	FA 03	5.0	9400	8.0	8.3
0.55	BN 71C	4	3.8	○	69.0	68.9	68.8	0.74	1.55	4.1	2.3	2.3	9.1	7.3	FD 53	7.5	4300	8700	10.2	10.0	FA 03	7.5	8700	10.2	9.7
0.55	BN 80A	4	3.8	○	72.0	71.3	69.7	0.77	1.43	4.1	2.3	2.0	15	8.2	FD 04	10	4100	8000	16.6	12.1	FA 04	10	8000	16.6	12.0
0.75	BN 80B	4	5.1	●	75.0	74.5	69.3	0.78	1.85	4.9	2.7	2.5	20	9.9	FD 04	15	4100	7800	22	13.8	FA 04	15	7800	22	13.7
1.1	BN 80C	4	7.5	●	75.5	76.2	70.4	0.78	2.7	5.1	2.8	2.5	25	11.3	FD 04	15	2600	5300	27	15.2	FA 04	15	5300	27	15.1
1.1	BN 90S	4	7.6	●	76.5	76.2	72.2	0.77	2.70	4.6	2.6	2.2	21	12.2	FD 14	15	4800	8000	23	16.4	FA 14	15	8000	23	16.3
1.5	BN 90LA	4	10.2	●	78.7	78.5	74.9	0.77	3.6	5.3	2.8	2.4	28	13.6	FD 05	26	3400	6000	32	19.6	FA 05	26	6000	32	20.3
1.85	BN 90LB	4	12.7	●	78.6	78.9	77.2	0.79	4.3	5.1	2.8	2.6	30	15.1	FD 05	26	3200	5900	34	21.1	FA 05	26	5900	34	21.8
2.2	BN 100LA	4	14.9	●	81.1	81.4	79.9	0.75	5.2	4.5	2.2	2.0	40	18	FD 15	40	2600	4700	44	25	FA 15	40	4700	44	25
3	BN 100LB	4	20	●	82.6	83.8	83.7	0.77	6.8	5.0	2.3	2.2	54	22	FD 15	40	2400	4400	58	28	FA 15	40	4400	58	29
4	BN 112M	4	27	●	84.4	84.2	81.6	0.81	8.4	5.6	2.7	2.5	98	30	FD 06S	60	—	1400	107	40	FA 06S	60	2100	107	42
5.5	BN 132S	4	36	●	84.7	84.8	82.5	0.81	11.6	5.5	2.3	2.2	213	44	FD 56	75	—	1050	223	57	FA 06	75	1200	223	58
7.5	BN 132MA	4	50	●	86.0	86.3	85.3	0.81	15.5	5.7	2.5	2.4	270	53	FD 06	100	—	950	280	66	FA 07	100	1000	280	71
9.2	BN 132MB	4	61	●	88.4	88.6	87.5	0.81	18.8	5.9	2.7	2.5	319	59	FD 07	150	—	900	342	75	FA 07	150	900	342	77
11	BN 160MR	4	73	●	87.6	87.8	86.0	0.81	22.4	6.0	2.7	2.5	360	70	FD 07	150	—	850	382	86	FA 07	150	850	382	88
15	BN 160L	4	98	●	88.7	88.5	88.4	0.81	30	6.0	2.3	2.1	650	99	FD 08	200	—	750	725	129	FA 08	200	750	710	128
18.5	BN 180M	4	121	●	89.3	89.5	89.2	0.81	37	6.2	2.6	2.5	790	115	FD 08	250	—	700	865	145	FA 08	250	700	850	144
22	BN 180L	4	144	●	89.9	90.0	90.0	0.80	44	6.4	2.5	2.5	1250	135	FD 09	300	—	400	1450	175	FA 08	250	700	850	144
30	BN 200L	4	196	●	91.4	91.7	91.0	0.80	59	7.1	2.7	2.8	1650	157	FD 09	400	—	300	1850	197	FA 08	250	700	850	144

○ = n.a.    ● = IE1





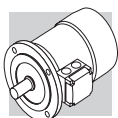

**6P** **1000 min<sup>-1</sup> - S1** **50 Hz**

P <sub>n</sub> kW		n min <sup>-1</sup>	M <sub>n</sub> Nm	IE1	η (100%) %	η (75%) %	η (50%) %	cosφ	In 400V A	Is In %	Ms Mn %	Ma Mn %	J <sub>m</sub> x 10 <sup>-4</sup> kgm <sup>2</sup>	IM B5  Kg	freno c.c.						freno c.a.							
															FD			FA			FD			FA				
															Mod	Mb Nm	Z <sub>0</sub> 1/h	NB	SB	Mod	Mb Nm	Z <sub>0</sub> 1/h	IM B5  Kg	J <sub>m</sub> x 10 <sup>-4</sup> kgm <sup>2</sup>	Mod	Mb Nm	Z <sub>0</sub> 1/h	IM B5  Kg
0.09	BN 63A	6	0.98	○	41.0	41.0	32.9	0.53	0.60	2.1	2.1	1.8	3.4	4.6	FD 02	3.5	9000	14000	4.0	FA 02	3.5	14000	6.3	4.0	FA 02	3.5	14000	6.1
0.12	BN 63B	6	1.32	○	45.0	44.0	41.8	0.60	0.64	2.1	1.9	1.7	3.7	4.9	FD 02	3.5	9000	14000	4.3	FA 02	3.5	14000	6.6	4.3	FA 02	3.5	14000	6.4
0.18	BN 71A	6	1.91	○	55.0	55.5	51.0	0.69	0.68	2.6	1.9	1.7	8.4	5.5	FD 03	5	8100	13500	9.5	FA 03	5.0	13500	8.2	9.5	FA 03	5.0	13500	7.9
0.25	BN 71B	6	2.70	○	62.0	58.5	51.4	0.71	0.82	2.6	1.9	1.7	10.9	6.7	FD 03	5	7800	13000	12	FA 03	5.0	13000	9.4	12	FA 03	5.0	13000	9.1
0.37	BN 71C	6	3.9	○	66.0	60.0	53.3	0.69	1.17	3.0	2.4	2.0	12.9	7.7	FD 53	7.5	5100	9500	14	FA 03	7.5	9500	10.4	14	FA 03	7.5	9500	10.1
0.37	BN 80A	6	3.9	○	68.0	67.4	63.3	0.68	1.15	3.2	2.2	2.0	21	9.9	FD 04	10	5200	8500	23	FA 04	10	8500	13.8	23	FA 04	10	8500	13.7
0.55	BN 80B	6	5.7	○	70.0	69.8	64.3	0.68	1.67	3.9	2.6	2.2	25	11.3	FD 04	15	4800	7200	27	FA 04	15	7200	15.2	27	FA 04	15	7200	15.1
0.75	BN 80C	6	7.8	●	70.0	70.0	64.4	0.65	2.38	3.8	2.5	2.2	28	12.2	FD 04	15	3400	6400	30	FA 04	15	6400	16.1	30	FA 04	15	6400	16.0
0.75	BN 90S	6	7.8	●	70.0	69.0	64.2	0.68	2.27	3.8	2.4	2.2	26	12.6	FD 14	15	3400	6500	28	FA 14	15	6500	16.8	28	FA 14	15	6500	16.7
1.1	BN 90L	6	11.4	●	72.9	72.6	69.1	0.69	3.2	3.9	2.3	2.0	33	15	FD 05	26	2700	5000	37	FA 05	26	5000	21	37	FA 05	26	5000	22
1.5	BN 100LA	6	15.2	●	75.2	74.2	70.3	0.72	4.0	4.1	2.1	2.0	82	22	FD 15	40	1900	4100	86	FA 15	40	4100	28	86	FA 15	40	4100	29
1.85	BN 100LB	6	19.0	●	76.6	72.8	62.6	0.73	4.8	4.6	2.1	2.0	95	24	FD 15	40	1700	3600	99	FA 15	40	3600	30	99	FA 15	40	3600	31
2.2	BN 112M	6	22	●	78.5	79.0	76.5	0.73	5.5	4.8	2.2	2.0	168	32	FD 06S	60	—	2100	177	FA 06S	60	2100	42	177	FA 06S	60	2100	44
3	BN 132S	6	30	●	79.7	77.0	75.1	0.76	7.1	5.1	1.9	1.8	216	36	FD 56	75	—	1400	226	FA 06	75	1400	49	226	FA 06	75	1400	50
4	BN 132MA	6	40	●	81.4	81.5	79.5	0.77	9.2	5.5	2.0	1.8	295	45	FD 06	100	—	1200	305	FA 07	100	1200	58	305	FA 07	100	1200	63
5.5	BN 132MB	6	56	●	83.1	80.9	79.1	0.78	12.2	6.1	2.1	1.9	383	56	FD 07	150	—	1050	406	FA 07	150	1050	72	406	FA 07	150	1050	74
7.5	BN 160M	6	75	●	85.0	85.0	84.8	0.81	15.7	5.9	2.2	2.0	740	83	FD 08	170	—	900	815	FA 08	170	900	112	815	FA 08	170	900	113
11	BN 160L	6	109	●	86.4	86.5	85.9	0.81	22.7	6.6	2.5	2.3	970	103	FD 08	200	—	800	1045	FA 08	200	800	133	1045	FA 08	200	800	133
15	BN 180L	6	148	●	87.7	88.0	87.3	0.82	30	6.2	2.0	2.4	1550	130	FD 09	300	—	600	1750	FA 09	300	600	170	1750	FA 09	300	600	170
18.5	BN 200LA	6	184	●	88.6	88.0	87.3	0.81	37	5.9	2.0	2.3	1700	145	FD 09	400	—	450	1900	FA 09	400	450	185	1900	FA 09	400	450	185

○ = n.a.    ● = IE1



8P		750 min <sup>-1</sup> - S1												50 Hz								
		freno C.C.												freno C.a.								
P <sub>n</sub> kW		n min <sup>-1</sup>	M <sub>n</sub> Nm	η %	cosφ	I <sub>n</sub> 400V A	I <sub>s</sub> I <sub>n</sub>	M <sub>s</sub> M <sub>n</sub>	M <sub>a</sub> M <sub>n</sub>	J <sub>m</sub> x 10 <sup>-4</sup> kgm <sup>2</sup>	IM B5 	Mod	Mb Nm	Z <sub>o</sub> 1/h	SB	J <sub>m</sub> x 10 <sup>-4</sup> kgm <sup>2</sup>	IM B5 	Mod	Mb Nm	Z <sub>o</sub> 1/h	J <sub>m</sub> x 10 <sup>-4</sup> kgm <sup>2</sup>	IM B5 
0.09	BN 71A	8	1.26	47	0.59	0.47	2.3	2.4	2.3	10.9	6.7	FD 03	3.5	9000	16000	12.0	9.4	FA 03	3.5	16000	12.0	9.1
0.12	BN 71B	8	1.69	51	0.59	0.58	2.1	2.3	2.2	12.9	7.7	FD 03	5.0	9000	16000	14.0	10.4	FA 03	5.0	16000	14.0	10.1
0.18	BN 80A	8	2.49	51	0.60	0.85	2.4	2.2	2.2	15	8.2	FD 04	5.0	6500	11000	16.6	12.1	FA 04	5.0	11000	16.6	12.0
0.25	BN 80B	8	3.51	54	0.63	1.06	2.4	2.0	1.9	20	9.9	FD 04	10.0	6000	10000	22	13.8	FA 04	10.0	10000	23	13.7
0.37	BN 90S	8	5.2	58	0.60	1.53	2.6	2.3	2.1	26	12.6	FD 14	15.0	4800	7500	28	16.8	FA 14	15.0	7500	28	16.7
0.55	BN 90L	8	7.8	62	0.60	2.13	2.6	2.2	2.0	33	15	FD 05	26	4000	6400	37	21	FA 05	26	6400	37	22
0.75	BN 100LA	8	10.2	68	0.63	2.53	3.4	1.9	1.7	82	22	FD 15	26	2800	4800	86	28	FA 15	26	4800	86	29
1.1	BN 100LB	8	15.0	68	0.64	3.65	3.2	1.7	1.7	95	24	FD 15	40	2500	4000	99	30	FA 15	40	4000	99	31
1.5	BN 112M	8	20.2	71	0.66	4.6	3.7	1.8	1.9	168	32	FD 06S	60	—	3000	177	42	FA 06S	60	3000	177	44
2.2	BN 132S	8	29.6	75	0.66	6.4	3.8	1.8	2.0	295	45	FD 56	75	—	2300	305	58	FA 06	75	2300	305	56
3	BN 132MA	8	40.4	76	0.69	8.3	3.9	1.6	1.8	370	53	FD 06	100	—	1900	394	69	FA 07	100	1900	406	74



**2/4P** **3000/1500 min<sup>-1</sup> - S1** **50 Hz**

P <sub>n</sub> kW		freno c.c.														freno c.a.												
		FD														FA												
		IM B5 Kg	J <sub>m</sub> x 10 <sup>-4</sup> kgm <sup>2</sup>	M <sub>a</sub> M <sub>n</sub>	M <sub>s</sub> M <sub>n</sub>	I <sub>s</sub> I <sub>n</sub>	cos φ	η	M <sub>n</sub> Nm	n min <sup>-1</sup>	Mod	Mb Nm	Z <sub>0</sub> 1/h	NB	SB	J <sub>m</sub> x 10 <sup>-4</sup> kgm <sup>2</sup>	IM B5 Kg	Mod	Mb Nm	Z <sub>0</sub> 1/h	J <sub>m</sub> x 10 <sup>-4</sup> kgm <sup>2</sup>	IM B5 Kg						
0.20	2	BN 63B	2	2700	0.71	55	0.82	0.64	3.5	2.1	1.9	2.9	4.4	FD 02	3.5	2200	2600	4000	5100	3.5	6.1	FA 02	3.5	2600	5100	3.5	5.9	
0.15	4		4	1350	1.06	49	0.67	0.66	2.6	1.8	1.7																	
0.28	2	BN 71A	2	2700	0.99	56	0.82	0.88	2.9	1.9	1.7	4.7	4.4	FD 03	3.5	2100	2400	3800	4800	5.8	7.1	FA 03	3.5	2400	4800	5.8	6.8	
0.20	4		4	1370	1.39	59	0.72	0.68	3.1	1.8	1.7																	
0.37	2	BN 71B	2	2740	1.29	56	0.82	1.16	3.5	1.8	1.8	5.8	5.1	FD 03	5.0	1400	2100	2900	4200	6.9	7.8	FA 03	5.0	2100	4200	6.9	7.5	
0.25	4		4	1390	1.72	60	0.73	0.82	3.3	2.0	1.9																	
0.45	2	BN 71C	2	2780	1.55	63	0.85	1.21	3.8	1.8	1.8	6.9	5.9	FD 03	5.0	1400	2100	2800	4200	8.0	8.6	FA 03	5.0	2100	4200	8.0	8.3	
0.30	4		4	1400	2.0	63	0.73	0.94	3.6	2.0	1.9																	
0.55	2	BN 80A	2	2800	1.9	63	0.85	1.48	3.9	1.7	1.7	15	8.2	FD 04	5.0	1600	2300	3000	4000	17	12.1	FA 04	5.0	2300	4000	17	12.0	
0.37	4		4	1400	2.5	67	0.79	1.01	4.1	1.8	1.9																	
0.75	2	BN 80B	2	2780	2.6	65	0.85	1.96	3.8	1.9	1.8	20	9.9	FD 04	10	1400	1600	2700	3600	22	13.8	FA 04	10	1600	3600	22	13.7	
0.55	4		4	1400	3.8	68	0.81	1.44	3.9	1.7	1.7																	
1.1	2	BN 90S	2	2790	3.8	71	0.82	2.73	4.7	2.3	2.0	21	12.2	FD 14	10	1500	1600	2300	2800	23	16.4	FA 14	10	1600	2800	23	16.3	
0.75	4		4	1390	5.2	66	0.79	2.08	4.6	2.4	2.2																	
1.5	2	BN 90L	2	2780	5.2	70	0.85	3.64	4.5	2.4	2.1	28	14.0	FD 05	26	1050	1200	1600	2000	32	20	FA 05	26	1200	2000	32	21	
1.1	4		4	1390	7.6	73	0.81	2.69	4.7	2.5	2.2																	
2.2	2	BN 100LA	2	2800	7.5	72	0.85	5.2	4.5	2.0	1.9	40	18.3	FD 15	26	600	900	1300	2300	44	25	FA 15	26	900	2300	44	25	
1.5	4		4	1410	10.2	73	0.79	3.8	4.7	2.0	2.0																	
3.5	2	BN 100LB	2	2850	11.7	80	0.84	7.5	5.4	2.2	2.1	61	25	FD 15	40	500	900	1000	2100	65	31	FA 15	40	900	2100	65	32	
2.5	4		4	1420	16.8	82	0.80	5.5	5.2	2.2	2.2																	
4	2	BN 112M	2	2880	13.3	79	0.83	8.8	6.1	2.4	2.0	98	30	FD 06S	60	—	700	107	1200	107	40	FA 06S	60	700	107	107	42	
3.3	4		4	1420	22.2	80	0.80	7.4	5.1	2.1	2.0																	
5.5	2	BN 132S	2	2890	18.2	80	0.87	11.4	5.9	2.4	2.0	213	44	FD 56	75	—	350	223	350	223	57	FA 06	75	350	223	223	58	
4.4	4		4	1440	29	82	0.84	9.2	5.3	2.2	2.0																	
7.5	2	BN 132MA	2	2900	25	82	0.87	15.2	6.5	2.4	2.0	270	53	FD 06	100	—	350	280	350	280	66	FA 07	100	350	280	280	71	
6	4		4	1430	40	84	0.85	12.1	5.8	2.3	2.1																	
9.2	2	BN 132MB	2	2920	30	83	0.86	18.6	6.0	2.6	2.2	319	59	FD 07	150	—	300	342	300	342	75	FA 07	150	300	342	342	77	
7.3	4		4	1440	48	85	0.85	14.6	5.5	2.3	2.1																	

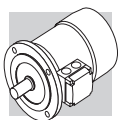



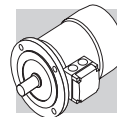

2/6P		3000/1000 min <sup>-1</sup> - S3 60/40%														50 HZ							
		freno c.c.														freno c.a.							
		FD							FA														
P <sub>n</sub>	kW	P <sub>n</sub>	n	M <sub>n</sub>	η	cosφ	I <sub>n</sub> 400V	I <sub>s</sub> I <sub>n</sub>	M <sub>s</sub> M <sub>n</sub>	M <sub>a</sub> M <sub>n</sub>	J <sub>m</sub> x 10 <sup>-4</sup>	IM B5	Mod	M <sub>b</sub>	Z <sub>0</sub> 1/h	SB	J <sub>m</sub> x 10 <sup>-4</sup>	IM B5	Mod	M <sub>b</sub>	Z <sub>0</sub> 1/h	J <sub>m</sub> x 10 <sup>-4</sup>	IM B5
kgm <sup>2</sup>																							
0.25		2	2850	0.84	60	0.82	0.73	4.3	1.9	1.8	6.9	5.9	FD 03	1.75	1500	1700	8.0	8.6	FA 03	2.5	1700	8.0	8.3
0.08		6	910	0.84	43	0.70	0.38	2.1	1.4	1.5					10000	13000							
0.37		2	2880	1.23	62	0.80	1.08	4.4	1.9	1.8	9.1	7.3	FD 03	3.5	1000	1300	10.2	10.0	FA 03	3.5	1300	10.2	9.7
0.12		6	900	1.27	44	0.73	0.54	2.4	1.4	1.5					9000	11000							
0.55		2	2800	1.88	63	0.86	1.47	4.5	1.9	1.7	20	9.9	FD 04	5.0	1500	1800	22	13.8	FA 04	5.0	1800	22	13.7
0.18		6	930	1.85	52	0.65	0.77	3.3	2.0	1.9					4100	6300							
0.75		2	2800	2.6	66	0.87	1.89	4.3	1.8	1.6	25	11.3	FD 04	5.0	1700	1900	27	15.2	FA 04	5.0	1900	27	15.1
0.25		6	930	2.6	54	0.67	1.00	3.2	1.7	1.8					3800	6000							
1.10		2	2860	3.7	67	0.84	2.82	4.7	2.1	1.9	28	14.0	FD 05	13	1400	1600	32	20	FA 05	13	1600	32	21
0.37		6	920	3.8	59	0.71	1.27	3.3	1.6	1.6					3400	5200							
1.5		2	2880	5	73	0.84	3.53	5.1	1.9	2.0	40	18.3	FD 15	13	1000	1200	44	24	FA 15	13	1200	44	25
0.55		6	940	5.6	64	0.67	1.85	3.5	1.7	1.8					2900	4000							
2.2		2	2900	7.2	77	0.85	4.9	5.9	2.0	2.0	61	25	FD 15	26	700	900	65	31	FA 15	26	900	65	32
0.75		6	950	7.5	67	0.64	2.5	3.3	1.9	1.8					2100	3000							
3		2	2900	9.9	78	0.87	6.4	6.3	2.0	2.1	98	30	FD 06S	40	—	1000	107	40	FA 06S	40	1000	107	32
1.1		6	950	11.1	72	0.64	3.4	3.9	1.8	1.8					—	2600							
4.5		2	2910	14.8	78	0.84	9.9	5.8	1.9	1.8	213	44	FD 66	37	—	500	223	57	FA 06	37	500	223	58
1.5		6	960	14.9	74	0.67	4.4	4.2	1.9	2.0					—	2100							
5.5		2	2920	18.0	78	0.87	11.7	6.2	2.1	1.9	270	53	FD 66	50	—	400	280	66	FA 06	50	400	280	67
2.2		6	960	22	77	0.71	5.8	4.3	2.1	2.0					—	1900							





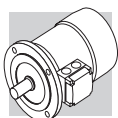

**2/8P** **3000/750 min-1 - S3 60/40%** **50 Hz**

P <sub>n</sub> kW			n min <sup>-1</sup>	M <sub>n</sub> Nm	η	cos φ	I <sub>n</sub> 400V A	I <sub>s</sub> I <sub>n</sub>	M <sub>s</sub> M <sub>n</sub>	M <sub>a</sub> M <sub>n</sub>	J <sub>m</sub> x 10 <sup>-4</sup> kgm <sup>2</sup>	IM B5 	freno c.c.						freno c.a.							
													FD			FA			FD			FA				
													Mod	Mb	Z <sub>o</sub> 1/h	NB	SB	Mod	Mb	Z <sub>o</sub> 1/h	IM B5 	J <sub>m</sub> x 10 <sup>-4</sup> kgm <sup>2</sup>	Mod	Mb	Z <sub>o</sub> 1/h	IM B5 
0.25	0.06	2	2790	0.86	61	0.87	0.68	3.9	1.8	1.9	10.9	6.7	FD 03	1.75	1300	1400	1400	1400	12	9.4	FA 03	2.5	1400	1400	12	9.1
		8	680	0.84	31	0.61	0.46	2.0	1.8	1.9		10000			10000	13000	13000	13000					13000	13000		
0.37	0.09	2	2800	1.26	63	0.86	0.99	3.9	1.8	1.9	12.9	7.7	FD 03	3.5	1200	1300	1300	1300	14	10.4	FA 03	3.5	1300	1300	14	10.1
		8	670	1.28	34	0.75	0.51	1.8	1.4	1.5		9500			9500	13000	13000	13000					13000	13000		
0.55	0.13	2	2830	1.86	66	0.86	1.40	4.4	2.1	2.0	20	9.9	FD 04	5.0	1500	1800	1800	1800	22	13.8	FA 04	5.0	1800	1800	22	13.7
		8	690	1.80	41	0.64	0.72	2.3	1.6	1.7		5600			5600	8000	8000	8000					8000	8000		
0.75	0.18	2	2800	2.6	68	0.88	1.81	4.6	2.1	2.0	25	11.3	FD 04	10	1700	1900	1900	1900	27	15.2	FA 04	10	1900	1900	27	15.1
		8	690	2.5	43	0.66	0.92	2.3	1.6	1.7		4800			4800	7300	7300	7300					7300	7300		
1.10	0.28	2	2830	3.7	63	0.84	3.00	4.5	2.1	1.9	28	14.0	FD 05	13	1400	1600	1600	1600	32	20	FA 05	13	1600	1600	32	21
		8	690	3.9	48	0.63	1.34	2.4	1.8	1.9		3400			3400	5100	5100	5100					5100	5100		
1.5	0.37	2	2880	5.0	69	0.85	3.69	4.7	1.9	1.8	40	18.3	FD 15	13	1000	1200	1200	1200	44	25	FA 15	13	1200	1200	44	25
		8	690	5.1	46	0.63	1.84	2.1	1.6	1.6		3300			3300	5000	5000	5000					5000	5000		
2.4	0.55	2	2900	7.9	75	0.82	5.6	5.4	2.1	2.0	61	25	FD 15	26	550	700	700	700	65	31	FA 15	26	700	700	65	32
		8	700	7.5	54	0.58	2.5	2.6	1.8	1.8		2000			2000	3500	3500	3500					3500	3500		
3	0.75	2	2900	9.9	76	0.87	6.5	6.3	2.1	1.9	98	30	FD 06S	40	—	900	900	900	107	40	FA 06S	40	900	900	107	42
		8	690	10.4	60	0.65	2.8	2.5	1.6	1.6		—			—	2900	2900	2900					2900	2900		
4	1	2	2870	13.3	73	0.84	9.4	5.6	2.3	2.4	213	44	FD 66	37	—	500	500	500	223	57	FA 06	37	500	500	223	58
		8	690	13.8	66	0.62	3.5	2.9	1.9	1.8		—			—	3500	3500	3500					3500	3500		
5.5	1.5	2	2870	18.3	75	0.84	12.6	6.1	2.4	2.5	270	53	FD 06	50	—	400	400	400	280	66	FA 06	50	400	400	280	67
		8	690	21	68	0.63	5.1	2.9	1.9	1.9		—			—	2400	2400	2400					2400	2400		





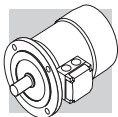

**2/12P** **3000/500 min-1 - S3 60/40%** **50 Hz**

P <sub>n</sub> kW			n min <sup>-1</sup>	M <sub>n</sub> Nm	η %	cos φ	I <sub>n</sub> 400V A	I <sub>s</sub> I <sub>n</sub>	M <sub>s</sub> M <sub>n</sub>	M <sub>a</sub> M <sub>n</sub>	J <sub>m</sub> x 10 <sup>-4</sup> kgm <sup>2</sup>	IM B5 	freno c.c.						freno c.a.					
													FD			FA			FD			FA		
													Mod	Mb Nm	Z <sub>0</sub> 1/h	NB	SB	Mod	Mb Nm	Z <sub>0</sub> 1/h	IM B5 	J <sub>m</sub> x 10 <sup>-4</sup> kgm <sup>2</sup>	Mod	Mb Nm
0.55 0.09	<b>BN 80B</b>	2 12	2820 430	1.86 2.0	64 30	0.89 0.63	1.39 0.69	4.2 1.8	1.6 1.9	1.7 1.8	25	11.3	FD 04	5.0	1000 8000	1300 12000	27	15.2	FA 04	5.0	1300 12000	27	15.1	
0.75 0.12	<b>BN 90L</b>	2 12	2790 430	2.6 2.7	56 26	0.89 0.63	2.17 1.06	4.2 1.7	1.8 1.4	1.7 1.6	26	12.6	FD 05	13	1000 4600	1150 6300	30	18.6	FA 05	13	1150 6300	30	19.3	
1.10 0.18	<b>BN 100LA</b>	2 12	2850 430	3.7 4.0	65 26	0.85 0.54	2.87 1.85	4.5 1.5	1.6 1.3	1.8 1.5	40	18.3	FD 15	13	700 4000	900 6000	44	25	FA 15	13	900 6000	44	25	
1.5 0.25	<b>BN 100LB</b>	2 12	2900 440	4.9 5.4	67 36	0.86 0.46	3.76 2.18	5.6 1.8	1.9 1.7	1.9 1.8	54	22	FD 15	13	700 3800	900 5000	58	28	FA 15	13	900 5000	58	29	
2 0.3	<b>BN 112M</b>	2 12	2900 460	6.6 6.2	74 46	0.88 0.43	4.43 2.19	6.5 2.0	2.1 2.1	2.0 2.0	98	30	FD 06S	20	— —	800 3400	107	40	FA 06S	20	800 3400	107	42	
3 0.5	<b>BN 132S</b>	2 12	2920 470	9.8 10.2	74 51	0.87 0.43	6.7 3.3	6.8 2.0	2.3 1.7	1.9 1.6	213	44	FD 56	37	— —	450 3000	223	57	FA 06	37	450 3000	223	58	
4 0.7	<b>BN 132M</b>	2 12	2920 460	13.1 14.5	75 53	0.89 0.44	8.6 4.3	5.9 1.9	2.4 1.7	2.3 1.6	270	53	FD 56	37	— —	400 2800	280	66	FA 06	37	400 2800	280	67	









4/8P		1500/750 min <sup>-1</sup> - S1														50 Hz					
		freno c.c.														freno c.a.					
		FD							FA												
P <sub>n</sub>		n	M <sub>n</sub>	η	cos φ	I <sub>n</sub>	I <sub>s</sub>	M <sub>s</sub>	M <sub>a</sub>	J <sub>m</sub>	IM B5	Mod	Mb	Z <sub>0</sub>	J <sub>m</sub>	IM B5	Mod	Mb	Z <sub>0</sub>	J <sub>m</sub>	IM B5
kW		min <sup>-1</sup>	Nm	%		A	$\frac{I_s}{I_n}$	$\frac{M_s}{M_n}$	$\frac{M_a}{M_n}$	x 10 <sup>-4</sup> kgm <sup>2</sup>			Nm	1/h	x 10 <sup>-4</sup> kgm <sup>2</sup>			Nm	1/h	x 10 <sup>-4</sup> kgm <sup>2</sup>	
0.37	BN 80A	4	2.5	63	0.82	1.03	3.3	1.4	1.4	15	8.2	FD 04	10	2300	16.6	12.1	FA 04	10	3500	16.6	12.0
0.18		8	2.5	44	0.60	0.98	2.2	1.5	1.6					4500	7000				7000		
0.55	BN 80B	4	3.8	65	0.86	1.42	3.8	1.7	1.6	20	9.9	FD 04	10	2200	22	13.8	FA 04	10	2900	22	13.7
0.30		8	4.3	49	0.65	1.36	2.3	1.7	1.8					4200	6500				6500		
0.65	BN 90S	4	4.5	73	0.85	1.51	4.0	1.9	1.9	28	13.6	FD 14	15	2300	30	17.8	FA 14	15	2800	30	17.7
0.35		8	4.8	49	0.57	1.81	2.5	2.1	2.2					3500	6000				6000		
0.9	BN 90L	4	6.3	73	0.87	2.05	3.8	1.8	1.8	30	15.1	FD 05	26	1700	34	21	FA 05	26	2100	34	22
0.5		8	7.1	57	0.62	2.04	2.4	2.1	2.0					2500	4200				4200		
1.30	BN 100LA	4	8.7	72	0.83	3.14	4.3	1.7	1.8	82	22	FD 15	40	1300	86	28	FA 15	40	1700	86	29
0.70		8	9.6	58	0.64	2.72	2.8	1.8	1.8					2000	3400				3400		
1.8	BN 100LB	4	12.1	69	0.87	4.3	4.2	1.6	1.7	95	25	FD 15	40	1200	99	31	FA 15	40	1700	99	32
0.9		8	12.3	62	0.63	3.3	3.2	1.7	1.8					1600	2600				2600		
2.2	BN 112M	4	14.6	77	0.85	4.9	5.3	1.8	1.8	168	32	FD 06S	60	—	177	42	FA 06S	60	1200	177	43
1.2		8	16.1	70	0.63	3.9	3.3	1.9	1.8					—	2000				2000		
3.6	BN 132S	4	24	80	0.82	7.9	6.5	2.1	1.9	295	45	FD 56	75	—	305	58	FA 06	75	1000	305	59
1.8		8	24	72	0.55	6.6	4.6	1.9	2.0					—	1400				1400		
4.6	BN 132M	4	30	81	0.83	9.9	6.5	2.2	1.9	383	56	FD 06	100	—	393	69	FA 07	100	1000	393	74
2.3		8	31	73	0.54	8.4	4.4	2.3	2.0					—	1300				1300		







**6P**      **1000 min<sup>-1</sup> - S1**      **50 Hz**

P <sub>n</sub> kW		n min <sup>-1</sup>	M <sub>n</sub> Nm	IE1	η (100%) %	η (75%) %	η (50%) %	cosφ	I <sub>n</sub> 400V A	I <sub>s</sub> I <sub>n</sub>	M <sub>s</sub> M <sub>n</sub>	M <sub>a</sub> M <sub>n</sub>	J <sub>m</sub> x 10 <sup>-4</sup> kgm <sup>2</sup>	IM B5 	freno c.c.								freno c.a.							
															FD				FA				FD				FA			
															Mod	Mb Nm	Z <sub>0</sub> 1/h	J <sub>m</sub> x 10 <sup>-4</sup> kgm <sup>2</sup>	IM B5 	Mod	Mb Nm	Z <sub>0</sub> 1/h	J <sub>m</sub> x 10 <sup>-4</sup> kgm <sup>2</sup>	IM B5 	Mod	Mb Nm	Z <sub>0</sub> 1/h	J <sub>m</sub> x 10 <sup>-4</sup> kgm <sup>2</sup>	IM B5 	
0.09	M 05A	6	0.98	○	41.0	41.0	32.9	0.53	0.60	2.1	2.1	1.8	3.4	4.3	FD 02	3.5	9000	14000	4.0	6.0	FA 02	3.5	14000	4.0	5.8					
0.12	M 05B	6	1.32	○	45.0	44.0	41.8	0.60	0.64	2.1	1.9	1.7	3.7	4.6	FD 02	3.5	9000	14000	4.3	6.3	FA 02	3.5	14000	4.3	6.1					
0.18	M 15C	6	1.91	○	55.0	55.5	51.0	0.69	0.68	2.6	1.9	1.7	8.4	5.1	FD 03	5	8100	13500	9.5	7.8	FA 03	5	13500	9.5	7.5					
0.25	M 15D	6	2.7	○	62.0	58.5	51.4	0.71	0.82	2.6	1.9	1.7	10.9	6.3	FD 03	5	7800	13000	12	9.0	FA 03	5	13000	12	8.7					
0.37	M 1LA	6	3.9	○	66.0	60.0	53.3	0.69	1.17	3.0	2.4	2.0	12.9	7.3	FD 53	7.5	5100	9500	14	10.0	FA 03	7.5	9500	14	9.7					
0.55	M 25A	6	5.7	○	70.0	69.8	64.3	0.68	1.67	3.9	2.6	2.2	25	10.6	FD 04	15	4800	7200	27	14.5	FA 04	15	7200	27	14.4					
0.75	M 25B	6	7.8	●	70.0	70.0	64.4	0.65	2.38	3.8	2.5	2.2	28	11.5	FD 04	15	3400	6400	30	15.4	FA 04	15	6400	30	15.3					
1.1	M 35A	6	11.4	●	75.0	74.0	72.0	0.72	2.9	4.3	2.0	1.8	33	17	FD 15	26	2700	5000	37	23	FA 15	26	5000	37	24					
1.5	M 3LA	6	15.2	●	75.2	74.2	70.3	0.72	4.0	4.1	2.1	2.0	82	21	FD 15	40	1900	4100	86	27	FA 15	40	4100	86	28					
1.85	M 3LB	6	19.0	●	76.6	72.8	62.6	0.73	4.8	4.6	2.1	2.0	95	23	FD 15	40	1700	3600	99	29	FA 15	40	3600	99	30					
2.2	M 3LC	6	23	●	77.7	76.8	72.4	0.71	5.8	4.7	2.3	2.1	95	23	FD 55	55	—	1900	99	29	FA 15	40	1900	99	30					
3	M 45A	6	30	●	79.7	77.0	75.1	0.76	7.1	5.1	1.9	1.8	216	34	FD 56	75	—	1400	226	47	FA 06	75	1400	226	48					
4	M 4LA	6	40	●	81.4	81.5	79.5	0.77	9.2	5.5	2.0	1.8	295	43	FD 06	100	—	1200	305	56	FA 07	100	1200	305	57					
5.5	M 4LB	6	56	●	83.1	80.9	79.1	0.78	12.2	6.1	2.1	1.9	383	54	FD 07	150	—	1050	406	70	FA 07	150	1050	406	72					
7.5	M 55A	6	75	●	85.0	85.0	84.8	0.81	15.7	5.9	2.2	2.0	740	69	FD 08	170	—	900	815	98	FA 08	170	900	800	98					
11	M 55B	6	109	●	86.4	86.5	85.9	0.81	22.7	6.6	2.5	2.3	970	89	FD 08	200	—	800	1045	119	FA 08	200	800	1030	118					

○ = n.a.      ● = IE1

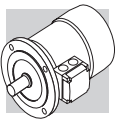



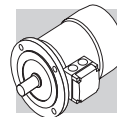

2/4P		3000/1500 min <sup>-1</sup> - S1														50 Hz										
		freno c.c.														freno c.a.										
		P <sub>n</sub> kW	IM B5	n min <sup>-1</sup>	M <sub>n</sub> Nm	η %	cos φ	I <sub>n</sub> 400V A	I <sub>s</sub> I <sub>n</sub>	M <sub>s</sub> M <sub>n</sub>	M <sub>a</sub> M <sub>n</sub>	J <sub>m</sub> x 10 <sup>-4</sup> kgm <sup>2</sup>	IM B5 Kg	Mod	Mb Nm	Z <sub>o</sub> 1/h	NB	SB	J <sub>m</sub> x 10 <sup>-4</sup> kgm <sup>2</sup>	IM B5 Kg	Mod	Mb Nm	Z <sub>o</sub> 1/h	J <sub>m</sub> x 10 <sup>-4</sup> kgm <sup>2</sup>	IM B5 Kg	
FD 02	FD 03																									FD 03
0.20	M 05A	2	2700	0.71	55	0.82	0.64	3.5	2.1	1.9	2.9	4.1	FD 02	3.5	2200	2600	2600	3.5	5.8	FA 02	3.5	2600	3.5	5.6		
0.15		4	1350	1.06	49	0.67	0.66	2.6	1.8	1.7				4000	5100	5100					5100					
0.28	M 1SB	2	2700	0.99	56	0.82	0.88	2.9	1.9	1.7	4.7	4.0	FD 03	3.5	2100	2400	2400	5.8	6.7	FA 03	3.5	2400	5.8	6.4		
0.20		4	1370	1.39	59	0.68	1.02	3.1	1.8	1.7				3800	4800	4800					4800					
0.37	M 1SC	2	2740	1.29	56	0.82	1.16	3.5	1.8	1.8	5.8	4.7	FD 03	5	1400	2100	2100	6.9	7.4	FA 03	5	2100	6.9	7.1		
0.25		4	1390	1.72	60	0.73	0.82	3.3	2.0	1.9				2900	4200	4200					4200					
0.45	M 1SD	2	2780	1.55	63	0.85	1.21	3.8	1.8	1.8	6.9	5.5	FD 03	5	1400	2100	2100	8.0	8.2	FA 03	5	2100	8.0	7.9		
0.30		4	1400	2.0	63	0.74	0.93	3.8	2.1	1.9				2800	4200	4200					4200					
0.55	M 1LA	2	2800	1.9	73	0.79	1.38	4.2	2.0	1.8	9.1	6.9	FD 03	5	1600	2200	2200	10.2	9.6	FA 03	5	2200	10.2	9.3		
0.37		4	1400	2.5	68	0.72	1.09	3.9	2.2	2.0				3300	4600	4600					4600					
0.75	M 2SA	2	2780	2.6	65	0.85	1.96	3.8	1.9	1.8	20	9.2	FD 04	10	1400	1600	1600	22	13.1	FA 04	10	1600	22	13.0		
0.55		4	1400	3.8	68	0.81	1.44	3.9	1.7	1.7				2700	3600	3600					3600					
1.1	M 2SB	2	2730	3.9	65	0.86	2.84	3.9	2.0	1.9	25	10.7	FD 04	10	1200	1500	1500	27	14.5	FA 04	10	1500	27	14.5		
0.75		4	1410	5.1	75	0.81	1.78	4.5	2.1	2.0				2300	3100	3100					3100					
1.5	M 3SA	2	2830	5.1	74	0.83	3.5	4.7	2.1	2.0	34	15.5	FD 15	26	700	1000	1000	38	22	FA 15	26	1000	38	23		
1.1		4	1420	7.4	77	0.78	2.6	4.3	2.1	2.0				1600	2600	2600					2600					
2.2	M 3LA	2	2800	7.5	72	0.85	5.2	4.5	2.0	1.9	40	17	FD 15	26	600	900	900	44	24	FA 15	26	900	44	24		
1.5		4	1410	10.2	73	0.79	3.8	4.7	2.0	2.0				1300	2300	2300					2300					
3.5	M 3LB	2	2850	11.7	80	0.84	7.5	5.4	2.2	2.1	61	23	FD 15	40	500	900	900	65	29	FA 15	40	900	65	30		
2.5		4	1420	16.8	82	0.80	5.5	5.2	2.2	2.2				1000	2100	2100					2100					
4.8	M 4 SA	2	2900	15.8	81	0.88	9.7	6.0	2.0	1.9	213	42	FD 06	50	—	400	400	233	55	FA 06	50	400	233	56		
3.8		4	1430	25.4	81	0.84	8.1	5.2	2.1	2.1				—	—	950	950				950					
5.5	M 4SB	2	2890	18.2	80	0.87	11.4	5.9	2.4	2.0	213	42	FD 56	75	—	350	350	223	55	FA 06	75	350	223	56		
4.4		4	1440	29	82	0.84	9.2	5.3	2.2	2.0				—	—	900	900				900					
7.5	M 4LA	2	2900	25	82	0.87	15.2	6.5	2.4	2.0	270	51	FD 06	100	—	350	350	280	64	FA 07	100	350	280	65		
6		4	1430	40	84	0.85	12.1	5.8	2.3	2.1				—	—	950	950				950					
9.2	M 4LB	2	2920	30	83	0.86	18.6	6.0	2.6	2.2	319	57	FD 07	150	—	300	300	342	73	FA 07	150	300	342	75		
7.3		4	1440	48	85	0.85	14.6	5.5	2.3	2.1				—	—	800	800				800					







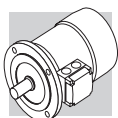

**2/6P** **3000/1000 min<sup>-1</sup> - S3 60/40%** **50 Hz**





P <sub>n</sub> kW			n min <sup>-1</sup>	M <sub>n</sub> Nm	η	cosφ	I <sub>n</sub> 400V A	I <sub>s</sub> I <sub>n</sub>	M <sub>s</sub> M <sub>n</sub>	M <sub>a</sub> M <sub>n</sub>	J <sub>m</sub> x 10 <sup>-4</sup> kgm <sup>2</sup>	IM B5 	freno c.c.						freno c.a.																					
													FD			FA			FD			FA																		
													Mod	Mb	Z <sub>o</sub> 1/h	NB	SB	IM B5 	J <sub>m</sub> x 10 <sup>-4</sup> kgm <sup>2</sup>	Mod	Mb	Z <sub>o</sub> 1/h	IM B5 	J <sub>m</sub> x 10 <sup>-4</sup> kgm <sup>2</sup>	Mod	Mb	Z <sub>o</sub> 1/h	IM B5 												
0.25	<b>M 1SA</b>	<b>2</b>	2850	0.84	60	0.82	0.73	4.3	1.9	1.8	6.9	5.5	<b>FD 03</b>	1.75	1700	1500	10000	1700	13000	<b>FA 03</b>	1.75	1700	13000	<b>FA 03</b>	1.75	1700	13000	<b>FA 03</b>	1.75	1700	13000	<b>FA 03</b>	1.75	1700	13000	8.0	8.0	8.0	8.0	
0.08		<b>6</b>	910	0.84	43	0.70	0.38	2.1	1.4	1.5																														
0.37	<b>M 1LA</b>	<b>2</b>	2880	1.23	62	0.80	1.08	4.4	1.9	1.8	9.1	6.9	<b>FD 03</b>	3.5	1300	1000	1300	11000	1300	102	<b>FA 03</b>	3.5	1300	102	<b>FA 03</b>	3.5	1300	102	<b>FA 03</b>	3.5	1300	102	<b>FA 03</b>	3.5	1300	102	10.2	10.2	10.2	10.2
0.12		<b>6</b>	900	1.27	44	0.73	0.54	2.4	1.4	1.5																														
0.55	<b>M 2SA</b>	<b>2</b>	2800	1.88	63	0.86	1.47	4.5	1.9	1.7	20	9.2	<b>FD 04</b>	5	1800	1500	1800	6000	1800	22	<b>FA 04</b>	5	1800	22	<b>FA 04</b>	5	1800	22	<b>FA 04</b>	5	1800	22	<b>FA 04</b>	5	1800	22	22	22	22	22
0.18		<b>6</b>	930	1.85	52	0.65	0.77	3.3	2.0	1.9																														
0.75	<b>M 2SB</b>	<b>2</b>	2800	2.6	66	0.87	1.89	4.3	1.8	1.6	25	10.6	<b>FD 04</b>	5	1700	1700	1900	6000	1700	27	<b>FA 04</b>	5	1700	27	<b>FA 04</b>	5	1700	27	<b>FA 04</b>	5	1700	27	<b>FA 04</b>	5	1700	27	27	27	27	27
0.25		<b>6</b>	930	2.6	54	0.67	1.00	3.2	1.7	1.8																														
1.1	<b>M 3SA</b>	<b>2</b>	2870	3.7	71	0.82	2.73	4.9	1.8	1.9	34	15.5	<b>FD 15</b>	13	1000	1000	1300	5000	1000	38	<b>FA 15</b>	13	1000	38	<b>FA 15</b>	13	1000	38	<b>FA 15</b>	13	1000	38	<b>FA 15</b>	13	1000	38	38	38	38	38
0.37		<b>6</b>	930	3.8	63	0.70	1.21	3.1	1.5	1.8																														
1.5	<b>M 3LA</b>	<b>2</b>	2880	5.0	73	0.84	3.53	5.1	1.9	2.0	40	17	<b>FD 15</b>	13	1000	1000	1200	4000	1000	44	<b>FA 15</b>	13	1000	44	<b>FA 15</b>	13	1000	44	<b>FA 15</b>	13	1000	44	<b>FA 15</b>	13	1000	44	44	44	44	44
0.55		<b>6</b>	940	5.6	64	0.67	1.85	3.5	1.7	1.8																														
2.2	<b>M 3LB</b>	<b>2</b>	2900	7.2	77	0.85	4.9	5.9	2.0	2.0	61	23	<b>FD 15</b>	26	700	700	900	3000	700	65	<b>FA 15</b>	26	700	65	<b>FA 15</b>	26	700	65	<b>FA 15</b>	26	700	65	<b>FA 15</b>	26	700	65	65	65	65	65
0.75		<b>6</b>	950	7.5	67	0.64	2.5	3.3	1.9	1.8																														
3	<b>M 4SA</b>	<b>2</b>	2910	9.9	74	0.88	6.6	5.6	2.0	2.1	170	36	<b>FD 56</b>	37	600	600	2200	1900	600	182	<b>FA 06</b>	37	600	182	<b>FA 06</b>	37	600	182	<b>FA 06</b>	37	600	182	<b>FA 06</b>	37	600	182	182	182	182	182
1.1		<b>6</b>	960	10.9	73	0.68	3.2	4.5	2.2	2.0																														
4.5	<b>M 4SB</b>	<b>2</b>	2910	14.8	78	0.84	9.9	5.8	1.9	1.8	213	42	<b>FD 56</b>	37	500	500	2100	1900	500	223	<b>FA 06</b>	37	500	223	<b>FA 06</b>	37	500	223	<b>FA 06</b>	37	500	223	<b>FA 06</b>	37	500	223	223	223	223	223
1.5		<b>6</b>	960	14.9	74	0.67	4.4	4.2	1.9	2.0																														
5.5	<b>M 4LA</b>	<b>2</b>	2920	18.0	78	0.87	11.7	6.2	2.1	1.9	270	51	<b>FD 06</b>	50	400	400	1900	1900	400	280	<b>FA 06</b>	50	400	280	<b>FA 06</b>	50	400	280	<b>FA 06</b>	50	400	280	<b>FA 06</b>	50	400	280	280	280	280	280
2.2		<b>6</b>	960	22	77	0.71	5.8	4.3	2.1	2.0																														



2/8P		3000/750 min <sup>-1</sup> - S3 60/40%														50 Hz						
		freno c.c.														freno c.a.						
		FD							FA													
P <sub>n</sub> kW		n min <sup>-1</sup>	M <sub>n</sub> Nm	η %	cos φ	I <sub>n</sub> 400V A	$\frac{I_s}{I_n}$	$\frac{M_s}{M_n}$	$\frac{M_a}{M_n}$	J <sub>m</sub> x 10 <sup>-4</sup> kgm <sup>2</sup>	IM B5 	Mod	Mb Nm	Z <sub>0</sub> 1/h	J <sub>m</sub> x 10 <sup>-4</sup> kgm <sup>2</sup>	IM B5 	Mod	Mb Nm	Z <sub>0</sub> 1/h	J <sub>m</sub> x 10 <sup>-4</sup> kgm <sup>2</sup>	IM B5 	
0.37	M 1LA	2	1.26	63	0.86	0.99	3.9	1.8	1.9	12.9	7.3	FD 03	3.5	1200	14	10.0	FA 03	3.5	1300	14	9.7	
0.09		8	1.28	34	0.75	0.51	1.8	1.4	1.5					9500	13000				13000			
0.55	M 2SA	2	1.86	66	0.86	1.40	4.4	2.1	2.0	20	9.2	FD 04	5	1500	22	13.1	FA 04	5	1800	22	13.0	
0.13		8	1.80	41	0.64	0.72	2.3	1.6	1.7					5600	8000				8000			
0.75	M 2SB	2	2.6	68	0.88	1.81	4.6	2.1	2.0	25	10.6	FD 04	10	1700	27	14.5	FA 04	10	1900	27	14.4	
0.18		8	2.5	43	0.66	0.92	2.3	1.6	1.7					4800	7300				7300			
1.1	M 3SA	2	3.7	69	0.84	2.74	4.6	1.8	1.7	34	15.5	FD 15	13	1000	38	22	FA 15	13	1300	38	23	
0.28		8	3.9	44	0.56	1.64	2.3	1.4	1.7					3400	5000				5000			
1.5	M 3LA	2	5.0	69	0.85	3.69	4.7	1.9	1.8	40	17	FD 15	13	1000	44	24	FA 15	13	1200	44	24	
0.37		8	5.1	46	0.63	1.84	2.1	1.6	1.6					3300	5000				5000			
2.4	M 3LB	2	7.9	75	0.82	5.6	5.4	2.1	2.0	61	23	FD 15	26	550	65	29	FA 15	26	700	65	30	
0.55		8	7.5	54	0.58	2.5	2.6	1.8	1.8					2000	3500				3500			
3	M 4SA	2	9.8	72	0.85	7.1	5.6	2.0	1.8	162	36	FD 56	37	—	182	48	FA 06	37	600	182	50	
0.75		8	10.1	61	0.64	2.8	3.0	1.7	1.8					—	3400				3400			
4	M 4SB	2	13.3	73	0.84	9.4	5.6	2.3	2.4	213	42	FD 56	37	—	223	55	FA 06	37	500	223	56	
1		8	13.8	66	0.62	3.5	2.9	1.9	1.8					—	3500				3500			
5.5	M 4LA	2	18.3	75	0.84	12.6	6.1	2.4	2.5	270	51	FD 06	50	—	280	64	FA 06	50	400	280	65	
1.5		8	21	68	0.63	5.1	2.9	1.9	1.9					—	2400				2400			



**2/12P**      **3000/500 min<sup>-1</sup> - S3 60/40%**      **50 Hz**

P <sub>n</sub> kW			n min <sup>-1</sup>	M <sub>n</sub> Nm	η %	cos φ	I <sub>n</sub> 400V A	I <sub>s</sub> I <sub>n</sub>	M <sub>s</sub> M <sub>n</sub>	M <sub>a</sub> M <sub>n</sub>	J <sub>m</sub> x 10 <sup>-4</sup> kgm <sup>2</sup>	IM B5 	freno c.c.						freno c.a.							
													FD			FA			FD			FA				
													Mod	Mb	Z <sub>0</sub> 1/h	NB	SB	Mod	Mb	Z <sub>0</sub> 1/h	IM B5 	J <sub>m</sub> x 10 <sup>-4</sup> kgm <sup>2</sup>	Mod	Mb	Z <sub>0</sub> 1/h	IM B5 
0.55	0.09	<b>M 2SA</b>	2 12	2820 430	1.86 2.0	64 30	0.89 0.63	1.39 0.69	4.2 1.8	1.6 1.9	1.7 1.8	25	10.6	5	1000 8000	1300 12000	27	14.5	5	1300 12000	27	14.4	5	1300 12000	27	14.4
0.75	0.12	<b>M 3SA</b>	2 12	2900 460	2.5 2.5	65 33	0.81 0.43	2.06 1.22	5.2 1.9	1.9 1.3	2.1 1.6	34	15.5	13	700 5000	900 7000	38	22	13	900 7000	38	23	13	900 7000	38	23
1.1	0.18	<b>M 3LA</b>	2 12	2850 430	3.7 4.0	65 26	0.85 0.54	2.87 1.85	4.5 1.5	1.6 1.3	1.8 1.5	40	17	13	700 4000	900 6000	44	24	13	900 6000	44	24	13	900 6000	44	24
1.5	0.25	<b>M 3LB</b>	2 12	2900 440	4.9 5.4	67 36	0.86 0.46	3.76 2.18	5.6 1.8	1.9 1.7	1.9 1.8	54	21	13	700 3800	900 5000	58	27	13	900 5000	58	28	13	900 5000	58	28
2	0.3	<b>M 3LC</b>	2 12	2850 450	6.7 6.4	70 38	0.84 0.47	4.9 2.4	4.9 1.7	1.8 1.6	1.7 1.7	61	23	18	— —	700 3500	65	29	18	700 3500	65	30	18	700 3500	65	30
3	0.5	<b>M 4SA</b>	2 12	2920 470	9.8 10.2	74 51	0.87 0.43	6.7 3.3	6.8 2.0	2.3 1.7	1.9 1.6	213	42	37	— —	450 3000	223	55	37	450 3000	223	56	37	450 3000	223	56
4	0.7	<b>M 4LA</b>	2 12	2920 460	13.1 14.5	75 53	0.89 0.44	8.6 4.3	5.9 1.9	2.4 1.7	2.3 1.6	270	51	37	— —	400 2800	280	64	37	400 2800	280	65	37	400 2800	280	65



M21 DIMENSIONI MOTORI BN-M

**BN - IM B5**

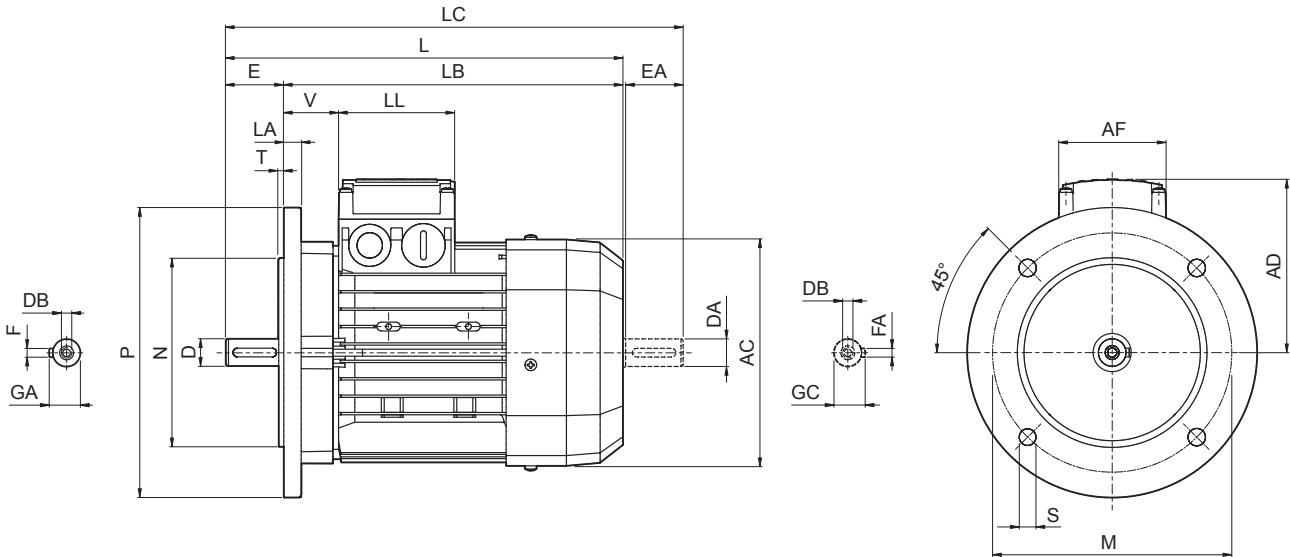

**BN-M**

	Albero					Flangia					Motore								
	D DA	E EA	DB	GA GC	F FA	M	N	P	S	T	LA	AC	L	LB	LC	AD	AF	LL	V
<b>BN 56</b>	9	20	M3	10.2	3	100	80	120	7	3	8	110	185	165	207	91	74	80	34
<b>BN 63</b>	11	23	M4	12.5	4	115	95	140	9.5		10	121	207	184	232	95			26
<b>BN 71</b>	14	30	M5	16	5	130	110	160			11.5	11.5	138	249	219	281			108
<b>BN 80</b>	19	40	M6	21.5	6	165	130	200	11.5	3.5	15	156	274	234	315	119	98	98	38
<b>BN 90</b>	24	50	M8	27	8						14	176	326	276	378	133			44
<b>BN 100</b>	28	60	M10	31	8	215	180	250	14	4	14	195	367	307	429	142	118	118	50
<b>BN 112</b>											15	219	385	325	448	157			52
<b>BN 132</b>	38	80	M12	41	10	265	230	300	18.5	5	20	258	493	413	576	193	187	187	58
<b>BN 160 MR</b>	42 38 <sup>(1)</sup>	110 80 <sup>(1)</sup>	M16 M12 <sup>(1)</sup>	45 41 <sup>(1)</sup>	12 10 <sup>(1)</sup>	300	250	350			15		310	596	486				680
<b>BN 160 M</b>									18	310	640	530	724	261	51				
<b>BN 160 L</b>	48 38 <sup>(1)</sup>	110 110 <sup>(1)</sup>	M16 M16 <sup>(1)</sup>	51.5 41 <sup>(1)</sup>	14 10 <sup>(1)</sup>	350	300	400	18.5	5	18	348	708	598	823	261	52		
<b>BN 180 M</b>											18	348	722	612	837	66			
<b>BN 180 L</b>	48 42 <sup>(1)</sup>	110 110 <sup>(1)</sup>	M16 M16 <sup>(1)</sup>	51.5 45 <sup>(1)</sup>	14 12 <sup>(1)</sup>	350	300	400	18.5	5	18	348	708	598	823	261	52		
<b>BN 200 L</b>											18	348	722	612	837	66			

N.B.:

1) Queste dimensioni sono riferite alla seconda estremità d'albero.



# BN - IM B14

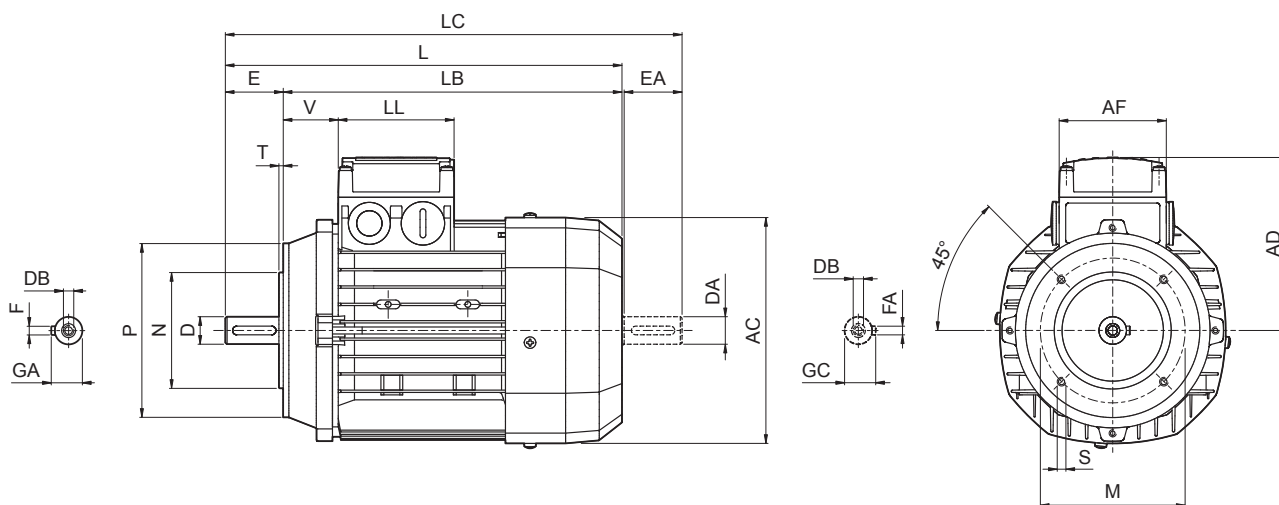

**BN-M**

	Albero					Flangia					Motore								
	D DA	E EA	DB	GA GC	F FA	M	N	P	S	T	AC	L	LB	LC	AD	AF	LL	V	
<b>BN 56</b>	9	20	M3	10.2	3	65	50	80	M5	2.5	110	185	165	207	91	74	80	34	
<b>BN 63</b>	11	23	M4	12.5	4	75	60	90			121	207	184	232	95			26	
<b>BN 71</b>	14	30	M5	16	5	85	70	105	M6		138	249	219	281	108			37	
<b>BN 80</b>	19	40	M6	21.5	6	100	80	120		156	274	234	315	119	38				
<b>BN 90</b>	24	50	M8	27	8	115	95	140	M8	3	176	326	276	378	133	98	98	44	
<b>BN 100</b>	28	60	M10	31		130	110	160			M8	3.5	195	367	307			429	142
<b>BN 112</b>					219	385	325	448	157				52						
<b>BN 132</b>	38	80	M12	41	10	165	130	200	M10	4	258	493	413	576	193	118	118	58	





## BN\_FD ; IM B14

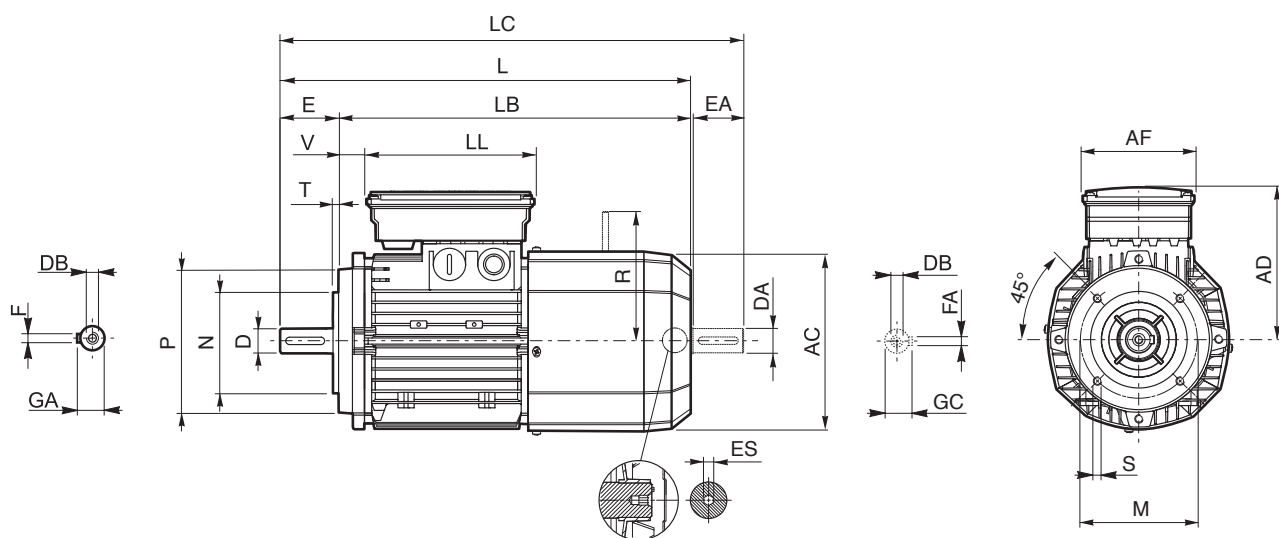

**BN-M**

	Albero					Flangia					Motore									
	D DA	E EA	DB	GA GC	F FA	M	N	P	S	T	AC	L	LB	LC	AD	AF	LL	V	R	ES
<b>BN 63</b>	11	23	M4	12.5	4	75	60	90	M5	2.5	121	272	249	297	122	98	133	14	96	5
<b>BN 71</b>	14	30	M5	16	5	85	70	105	M6		138	310	280	342	135			25	103	
<b>BN 80</b>	19	40	M6	21.5	6	100	80	120			156	346	306	388	146			41	129	
<b>BN 90 S</b>	24	50	M8	27	8	115	95	140	M8	3	176	409	359	461	110	165	39	129	6	
<b>BN 90 L</b>																				149
<b>BN 100</b>	146	160																		
<b>BN 112</b>	28	60	M10	31		130	110	160	3.5	195	458	398	521	158			62	199		
<b>BN 132</b>	38	80	M12	41	10	165	130	200		M10	4	258	603	523	686	210	140	188	46	204 <sup>(1)</sup>

N.B.:

1) Per freno FD07 quota R=226.

L'esagono ES non è presente con l'opzione PS.



## BN\_FA - IM B5

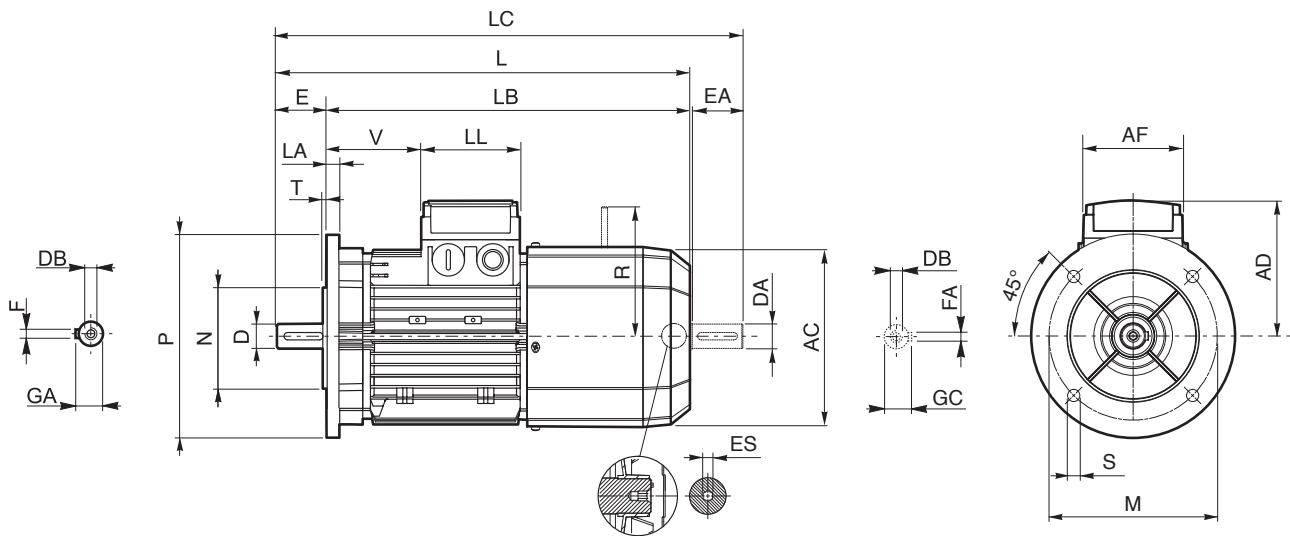

**BN-M**

	Albero					Flangia						Motore										
	D DA	E EA	DB	GA GC	F FA	M	N	P	S	T	LA	AC	L	LB	LC	AD	AF	LL	V	R	ES	
<b>BN 63</b>	11	23	M4	12.5	4	115	95	140	9.5	3	10	121	272	249	297	95	74	80	26	116	5	
<b>BN 71</b>	14	30	M5	16	5	130	110	160				138	310	280	342	108			68	124		
<b>BN 80</b>	19	40	M6	21.5	6	165	130	200	11.5	3.5	11.5	156	346	306	388	119	98	98	83	134	6	
<b>BN 90</b>	24	50	M8	27	176							409	359	461	133	95			160			
<b>BN 100</b>	28	60	M10	31	8	215	180	250	14	4	14	195	458	398	521	142	98	98	119	198	6	
<b>BN 112</b>												15	219	484	424	547			157	128		198
<b>BN 132</b>	38	80	M12	41	10	265	230	300	14	5	15	20	258	603	523	686	210	140	188	46	200 <sup>(2)</sup>	—
<b>BN 160 MR</b>	42 38 <sup>(1)</sup>	110 80 <sup>(1)</sup>	M16 M12 <sup>(1)</sup>	45 41 <sup>(1)</sup>	12 10 <sup>(1)</sup>	300	250	350				18.5		5	15	736	626	820	245	187	187	
<b>BN 160 M</b>									780	670	864		245			187	187	51	247			
<b>BN 160 L</b>									310	736	626		820			245	187	187	51	247		
<b>BN 180 M</b>	48 38 <sup>(1)</sup>	110 80 <sup>(1)</sup>	M16 M12 <sup>(1)</sup>	51.5 41 <sup>(1)</sup>	14 10 <sup>(1)</sup>	300	250	350	18.5	5	15	780	670	864	245	187	187	51	247	—		

N.B.:

- 1) Queste dimensioni sono riferite alla seconda estremità d'albero.
- 2) Per freno FA07 quota R=217.

Le dimensioni AD, AF, LL e V relative alla scatola morsettiera dei motori BN...FA dotati di alimentazione separata del freno (opzione SA) coincidono con quelle dei motori BN...FD di pari taglia.

L'esagono ES non è presente con l'opzione PS.





# BN\_FA - IM B14

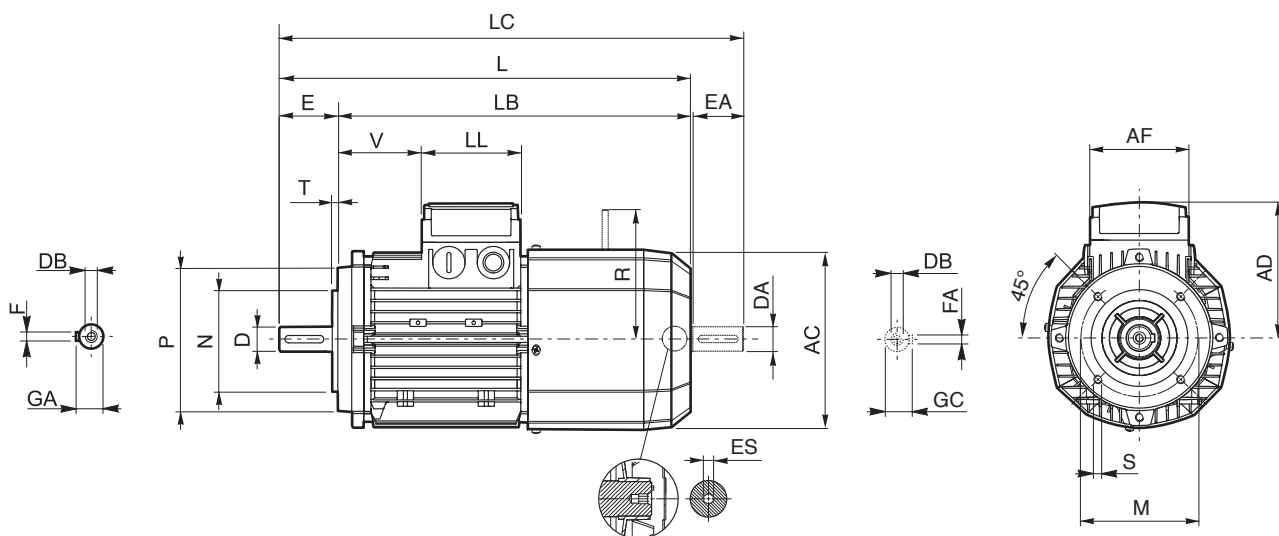

**BN-M**

	Albero					Flangia					Motore											
	D DA	E EA	DB	GA GC	F FA	M	N	P	S	T	AC	L	LB	LC	AD	AF	LL	V	R	ES		
<b>BN 63</b>	11	23	M4	12.5	4	75	60	90	M5	2.5	121	272	249	119	95	74	80	26	116	5		
<b>BN 71</b>	14	30	M5	16	5	85	70	105	M6		138	310	280	342	108			68	124			
<b>BN 80</b>	19	40	M6	21.5	6	100	80	120		3	156	346	306	388	119			83	134			
<b>BN 90</b>	24	50	M8	27	8	115	95	140	M8	3.5	176	409	359	461	133	98	98	95	160	6		
<b>BN 100</b>	28	60	M10	31		130	110	160			195	458	398	521	142			119	198			
<b>BN 112</b>						219	484	424		547	157	128	198									
<b>BN 132</b>	38	80	M12	41	10	165	130	200	M10	4	258	603	523	686	210			140	188		46	200 <sup>(1)</sup>

N.B.:

1) Per freno FA07 quota R=217.

Le dimensioni AD, AF, LL e V relative alla scatola morsettiera dei motori BN...FA dotati di alimentazione separata del freno (opzione SA) coincidono con quelle dei motori BN...FD di pari taglia.

L'esagono ES non è presente con l'opzione PS.



# M

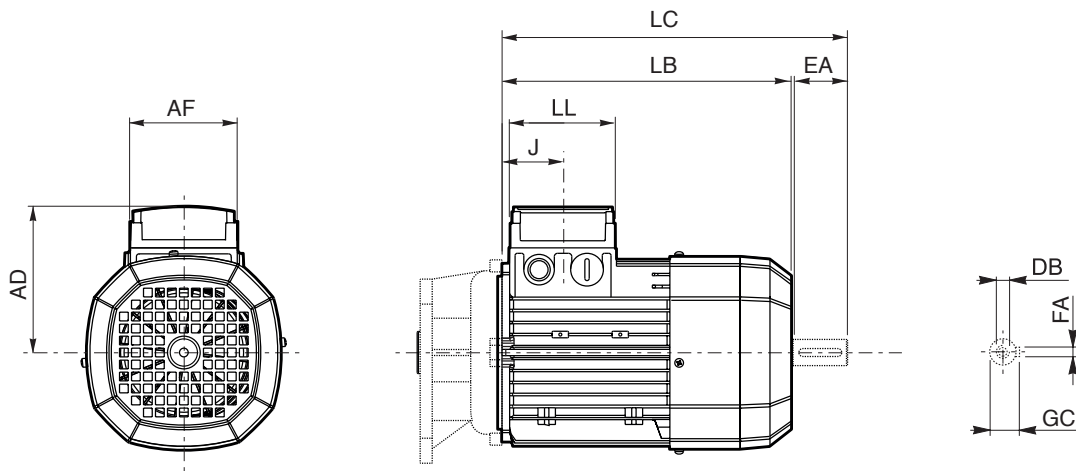

**BN-M**

	Seconda estremità albero					Motore						
	DA	EA	DB	FA	GC	AC	LB	LC	AF	LL	J	AD
<b>M 0</b>	9	20	M3	3	10.2	110	133	155	74	80	42	91
<b>M 05</b>	11	23	M4	4	12.5	121	165	191			48	95
<b>M 1</b>	14	30	M5	5	16	138	187	219			45	108
<b>M 2 S</b>	19	40	M6	6	21.5	156	202	245			44	119
<b>M 3 S</b>	28	60	M10	8	31	195	230	293	98	98	53.5	142
<b>M 3 L</b>							262	325				
<b>M 4</b>	38	80	M12	10	41	258	361	444	118	118	64.5	193
<b>M 4 LC</b>							396	479				
<b>M 5 S</b>						310	418	502	187	187	77	245
<b>M 5 L</b>							462	546				



# M\_FD

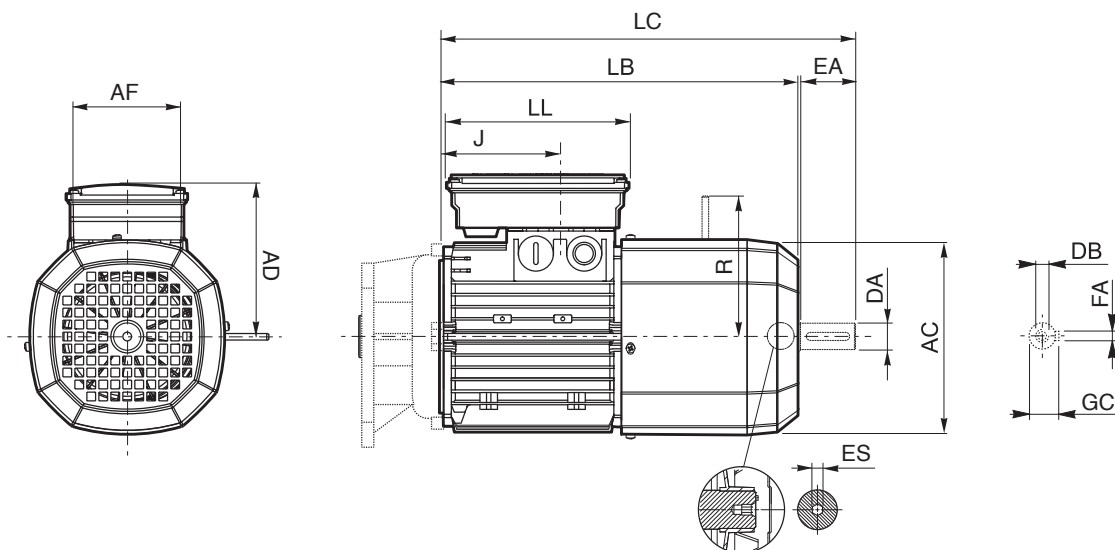

**BN-M**

	Seconda estremità albero					Motore								
	DA	EA	DB	FA	GC	AC	LB	LC	AF	LL	J	AD	R	ES
<b>M 05</b>	11	23	M4	4	12.5	121	231	256	98	133	48	122	96	5
<b>M 1</b>	14	30	M5	5	16	138	248	280			73	135	103	
<b>M 2 S</b>	19	40	M6	6	21.5	156	272	314			88	146	129	
<b>M 3 S</b>	28	60	M10	8	31	195	326	389	110	165	124.5	158	160	6
<b>M 3 L</b>							353	416						
<b>M 4</b>	38	80	M12	10	41	258	470	553	140	188	185.5	210	204 (1)	
<b>M 4 LC</b>							495	578			64.5		226	
<b>M 5 S</b>						310	558	642	187	187	77	245	266	
<b>M 5 L</b>							602	686						

N.B.:

1) Per freno FD07 quota R=226.

L'esagono ES non è presente con l'opzione PS.



# M\_FA

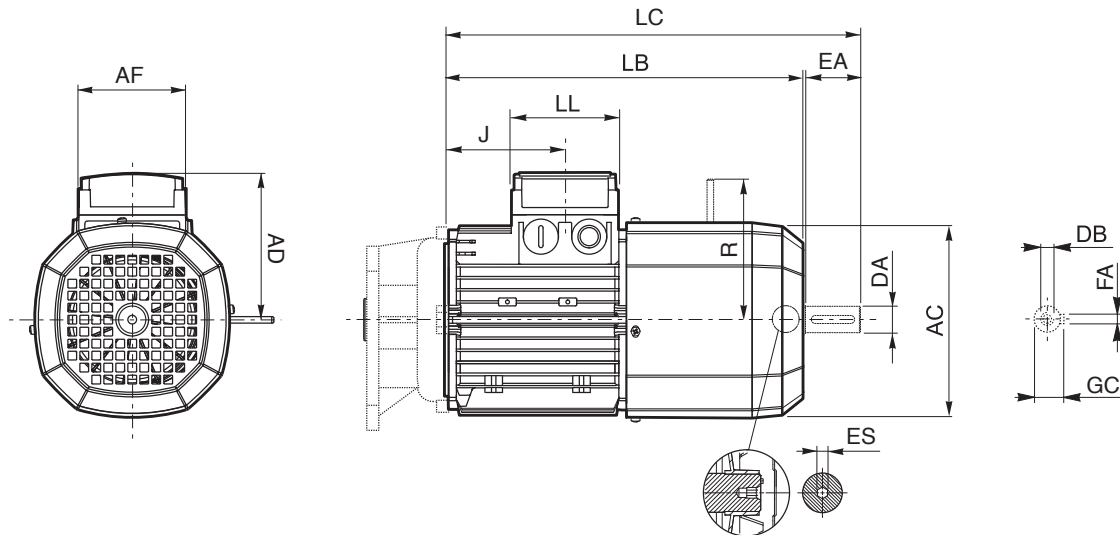

**BN-M**

	Seconda estremità albero					Motore									
	DA	EA	DB	FA	GC	AC	LB	LC	AF	LL	J	AD	R	ES	
<b>M 05</b>	11	23	M4	4	12.5	121	231	256	74	80	48	95	116	5	
<b>M 1</b>	14	30	M5	5	16	138	248	280			73	108	124		
<b>M 2 S</b>	19	40	M6	6	21.5	156	272	314			88	119	134		
<b>M 3 S</b>	28	60	M10	8	31	195	326	389	98	98	124.5	142	160	6	
<b>M 3 L</b>							353	416							
<b>M 4</b>	38	80	M14	10	41	258	470	553	140	188	185.5	210	200 (1)		
<b>M 4 LC</b>							495	578			64.5		217		
<b>M 5 S</b>			M12			310	558	642	187	187	77	245	247		—
<b>M 5 L</b>															

N.B.:

1) Per freno FA07 quota R=217.

Le dimensioni AD, AF, LL e V relative alla scatola morsettiera dei motori M...FA dotati di alimentazione separata del freno (opzione SA) coincidono con quelle dei motori M...FD di pari taglia

L'esagono ES non è presente con l'opzione PS.

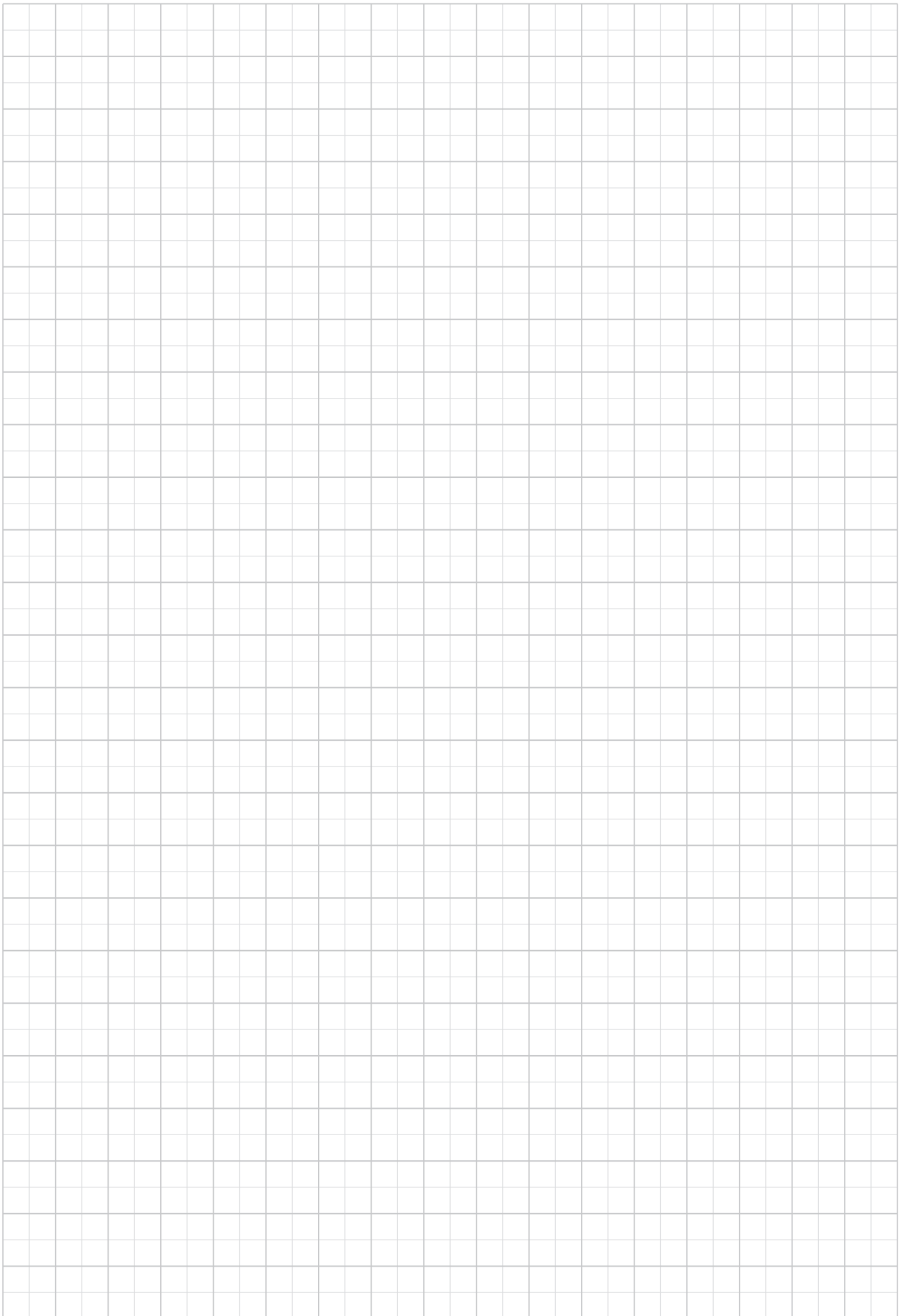



## INDICE DI REVISIONE

BR_CAT_VFW_IE2-IE3_ITA_R11_4	
	Descrizione
...	Aggiunto disponibilità motori elettrici BXN e MXN.
20	Aggiornato opzione "Lubrificazione".
107	Aggiornato tabella "Predisposizioni motore" per i riduttori VF/VF 30/44 e VF/VF 30/49.
121	Corretto caratteristiche motore elettrico BN27.
148...151	Corretto dimensione foro di fissaggio riduttori W110.
195	Corretto dimensioni riduttori VF 44L e VF 49L.
215...344	Aggiornato sezione "Motori elettrici".

2023 12 11

Questa pubblicazione annulla e sostituisce ogni precedente edizione o revisione. Ci riserviamo il diritto di apportare modifiche senza preavviso. È vietata la produzione anche parziale senza autorizzazione.





Abbiamo un'inflessibile dedizione per l'eccellenza, l'innovazione e la sostenibilità. Il nostro Team crea, distribuisce e supporta soluzioni di trasmissione e controllo di potenza per mantenere il mondo in movimento.

#### **HEADQUARTERS**

**Bonfiglioli S.p.A**

**Sede legale:** Via Cav. Clementino Bonfiglioli, 1  
40012 Calderara di Reno - Bologna (Italy)  
Tel. +39 051 6473111

**Sede operativa:** Via Isonzo, 65/67/69  
40033 Casalecchio di Reno - Bologna (Italy)

