

BONFIGLIOLI

eVOX INCLUDED
PLATFORM

BAUREIHE VF-W

IE2-IE3

Schneckengetriebe

 **Bonfiglioli**



Abschnitt	Beschreibung	Seite	Abschnitt	Beschreibung	Seite
ALLGEMEINE INFORMATIONEN		2	VF-EP / W-EP - GETRIEBE FÜR RAUE UMGEBUNGEN		197
1	Symbole und Maßeinheiten	2	33	Die vorteile der EP-Version für die Nahrungsmittelindustrie	197
2	Definitionen	3	34	Bezeichnung	200
3	Zulässige Temperaturgrenzen	6	35	Getriebe Optionen	202
4	Antriebsauswahl	7	36	Optionen Motoren	202
5	Prüfungen	9	37	Weitere informationen über Getriebe und Getriebemotoren	203
6	Installation	9	38	Zubehör der serie EP	203
7	Schmierung	11	ENDSCHALTER-VORRICHTUNG RVS		205
8	Lagerung	12	39	Allgemeine informationen	205
9	Lieferbedingungen	12	40	Art.-nr. für die Bestellung	206
SCHNECKENGETRIEBE		13	41	Bezeichnung	207
10	Konstruktive Eigenschaften	13	42	Getriebemotoren-auswahltabellen	208
11	Bauformen	14	43	Abmessungen	210
12	Bauform	15	44	Optionen	214
13	Bezeichnung	18	ELEKTROMOTOREN		215
14	Getriebe Optionen	20	M1	Symbole und Maßeinheiten	215
15	Einbaulagen und lage des klemmenkastens	25	M2	Einführung	216
16	Radialkräfte	34	M3	Allgemeine Eigenschaften	218
17	Axialkräfte	35	M4	Motorbezeichnung	220
18	Wirkungsgrad	38	M5	Bezeichnung für motoren	224
19	Selbsthemmung	38	M6	Mechanische Eigenschaften	227
20	Winkelspiele	40	M7	Elektrische Eigenschaften	232
21	Getriebemotorenauswahltabellen	41	M8	Drehstrombremsmotoren	244
22	Getriebe auswahltabellen	82	M9	Drehstrombremsmotoren mit Gleichstrom- bremse: typ _FD	245
23	Kombination der verhältnisse in den getrieben der serie VF/VF, VF/W, W/VF	104	M10	Wechselstrombremsmotoren: typ _FA	251
24	Motor Anbaumöglichkeiten	105	M11	Brenslüfthebel	255
25	Trägheitsmoment	108	M12	Optionen	257
26	Abmessungen für getriebemotoren und getrieben vorbereitet für IEC-motor	121	M13	Tabelle Motorzuordnung	271
27	Abmessungen für Getrieben mit cylindrischer antriebswelle	187	M14	Motorenauswahltabellen BXN-MXN	274
28	Abmessungen für Getriebe mit Drehmo- mentstütze	191	M15	Motorenabmessungen BXN-MXN	276
29	Abmessungen für Getriebe mit Schutzkappe	191	M16	Motorenauswahltabellen BX-MX	282
30	Zubehör	192	M17	Motorenabmessungen BX-MX	289
31	Maschinachse	193	M18	Motorenauswahltabellen BE-ME	301
32	Rutschkupplung	194	M19	Motorenabmessungen BE-ME	315
			M20	Motorenauswahltabellen BN-M	321
			M21	Motorenabmessungen BN-M	338

Änderungen

Das Revisionsverzeichnis des Katalogs wird auf Seite 348 wiedergegeben.

Auf unserer Website www.bonfiglioli.com werden die Kataloge in ihrer letzten, überarbeiteten Version angeboten.



ALLGEMEINEINFORMATIONEN

1 SYMBOLE UND MAßEINHEITEN

Symbole	Maßeinh.	Beschreibung	Symbole	Maßeinh.	Beschreibung
$A_{N 1,2}$	[N]	Nenn-Axialbelastung	$n_{1,2}$	[min ⁻¹]	Drehzahl
f_s	–	Betriebsfaktor	$P_{1,2}$	[kW]	Leistung
f_T	–	Wärmefaktor	$P_{N 1,2}$	[kW]	Nennleistung
f_{TP}	–	Temperaturfaktor	$P_{R 1,2}$	[kW]	Benötigte Leistung
i	–	Übersetzung	$R_{C 1,2}$	[N]	Berechnete Radiallast
l	–	Relative Einschaltdauer	$R_{N 1,2}$	[N]	Zulässige Radialbelastung
J_C	[Kgm ²]	Massenträgheitsmoment der externen Massen	S	–	Sicherheitsfaktor
J_M	[Kgm ²]	Motorträgheitsmoment	t_a	[°C]	Umgebungstemperatur
J_R	[Kgm ²]	Getriebeträgheitsmoment	t_s	[°C]	Oberflächentemperatur
K	–	Massenbeschleunigungsfaktor	t_o	[°C]	Öltemperatur
K_r	–	Korrekturfaktor	t_f	[min]	Betriebszeit unter Nennlast
$M_{1,2}$	[Nm]	Drehmoment	t_r	[min]	Stillstandszeit
$M_{c 1,2}$	[Nm]	Berechnetes Drehmoment	η_d	–	Dynamischer Wirkungsgrad
$M_{n 1,2}$	[Nm]	Nennmoment	η_s	–	Statischer Wirkungsgrad
$M_{r 1,2}$	[Nm]	Benötigtes Drehmoment			

¹ Werte beziehen sich auf die Antriebswelle

² Werte beziehen sich auf die Abtriebswelle



Dieses Symbol deutet auf besonders wichtige technische Informationen hin, die nicht vernachlässigt werden sollten.



Dieses Symbol gibt die Winkelbezugswerte für die Angabe der Richtung der Radialkräfte an (Stirnansicht der Welle).



Deutet auf schwerwiegende Gefahrensituationen hin, die bei Unterschätzung die Gesundheit und Sicherheit des Personals ernsthaft gefährden können.



Symbol für das Gewicht der Getriebe und der Getriebemotoren. Die in der Getriebemotoren-Tabelle genannten Werte schließen das Gewicht des vierpoligen Motors und die eingefüllte Schmierstoffmenge ein, sofern von BONFIGLIOLI RIDUTTORI vorgesehen.



Das Symbol Kennzeichnet die Seite, auf die die Information gefunden werden kann.

2 DEFINITIONEN

2.1 ABTRIEBSMOMENT

Nenn-Drehmoment M_{n2} [Nm]

Dies ist das an der Abtriebswelle übertragbare Drehmoment bei gleichförmiger Dauerbelastung bezogen auf die Antriebsdrehzahl n_1 und die entsprechende Abtriebsdrehzahl n_2 .

Das Drehmoment wird auf Grundlage eines Betriebsfaktor $f_s = 1$ berechnet.

Verlangtes Drehmoment M_{r2} [Nm]

Dies ist das von der Anwendung verlangte Drehmoment, das stets kleiner oder gleich dem Nenn-Abtriebsmoment M_{n2} des gewählten Getriebes sein muß.

Soll-Drehmoment M_{c2} [Nm]

Dies ist das bei der Wahl des Getriebes zugrundezulegende Drehmoment, wobei das übertragene Drehmoment M_{r2} und der Betriebsfaktor f_s zu berücksichtigen sind; das Soll-Drehmoment wird mit folgender Gleichung berechnet:

$$M_{c2} = M_{r2} \times f_s \leq M_{n2} \quad (1)$$

2.2 LEISTUNG

Nennleistung Antriebswelle P_{n1} [kW]

Diesen Parameter finden sie in den Getriebeauswahltabellen.

Er gibt die Leistung in kW an, welche durch das Getriebe sicher übertragen werden kann.

Die Werte beziehen sich auf die Eingangs-drehzahl n_1 und einen Betriebsfaktor von $f_s = 1$.



2.3 WIRKUNGSGRAD

Dynamischer Wirkungsgrad [η_d]

Er ist gegeben durch das Verhältnis der Abtriebsleistung P_2 zur Antriebsleistung P_1 :

$$\eta_d = \frac{P_2}{P_1} \quad (2)$$

Es soll hier insbesondere daran erinnert werden, daß die Katalogangaben für das Drehmoment M_{n2} auf Basis des dynamischen Wirkungsgrads η_d nach der Einlaufphase berechnet wurden.

Nach der Einlaufzeit erreicht man auch eine Reduzierung und endlich eine Stabilisierung der Betriebstemperatur. Die Betriebstemperatur wird von beiden Faktoren, von der Betriebsart und der Umgebungstemperatur, beeinflusst, die zulässigen Temperaturen werden im Kapitel "Zulässige Temperaturgrenzen" beschrieben. Wenn jedoch die zu erwartenden Oberflächentemperaturen an der oberen Grenze liegen empfehlen wir Viton Wellendichtringe, Option PV.

Statischer Wirkungsgrad [η_s]

Dies ist der Wirkungsgrad beim Anlaufen des Getriebes, der, obgleich er bei Zahnradgetrieben vernachlässigt werden kann, bei der Wahl von Antrieben mit Schneckengetrieben, die für den Aussetzbetrieb (z.B. Hubbetrieb) bestimmt sind, besondere Beachtung verdient.

2.4 GETRIEBEÜBERSETZUNG [i]

Die Übersetzung des Getriebes wird mit dem Buchstaben [i] bezeichnet und ist folgendermaßen Definiert:

$$i = \frac{n_1}{n_2} \quad (3)$$

2.5 TRÄGHEITSMOMENT J_r [kgm²]

Die im Katalog angegebenen Trägheitsmomente sind auf die Antriebswelle des Getriebes bezogen und daher im Falle einer direkten Verbindung schon zur Motordrehzahl in Beziehung gesetzt.



2.6 BETRIEBSFAKTOR [f_s]

Beim Betriebsfaktor handelt es sich um den Parameter, der die Betriebsbelastung, die das Getriebe aushalten muss, in einem Wert ausdrückt. Dabei berücksichtigt er, auch wenn nur mit einer unvermeidbaren Annäherung, den täglichen Einsatz, die unterschiedlichen Belastungen und eventuelle Überbelastungen, die mit der spezifischen Applikation des Getriebes verbunden sind. Der nachstehenden Grafik kann, nach der Wahl der entsprechenden Spalte mit der Angabe der täglichen Betriebsstunden der Betriebsfaktor entnommen werden, indem man die Schnittstelle zwischen der stündlichen Schaltungen und einer der Kurven K1, K2 und K3 sucht. Die mit K_ gekennzeichneten Kurven sind über den Beschleunigungsfaktor der Massen K an die Betriebsart gekoppelt (annähernd: gleichmäßige, mittlere oder starke Belastung), der wiederum an das Verhältnis zwischen Trägheitsmoment der angetriebenen Massen und dem des Motors gebunden ist. Unabhängig von dem so erhaltenen Betriebsfaktor, möchten wir Sie darauf hinweisen, dass es Applikationen gibt, unter denen beispielsweise auch die Hebefunktionen zu finden sind, bei denen das Nachgeben eines Getriebeorgans, das in dessen Nähe arbeitende Personal einer Verletzungsgefahr aussetzen könnte. Sollten daher Zweifel darüber bestehen, ob die entsprechende Applikation sich in diesem Bezug als kritisch erweist, bitten wir Sie sich zuvor mit unseren Technischen Kundendienst in Verbindung zu setzen.

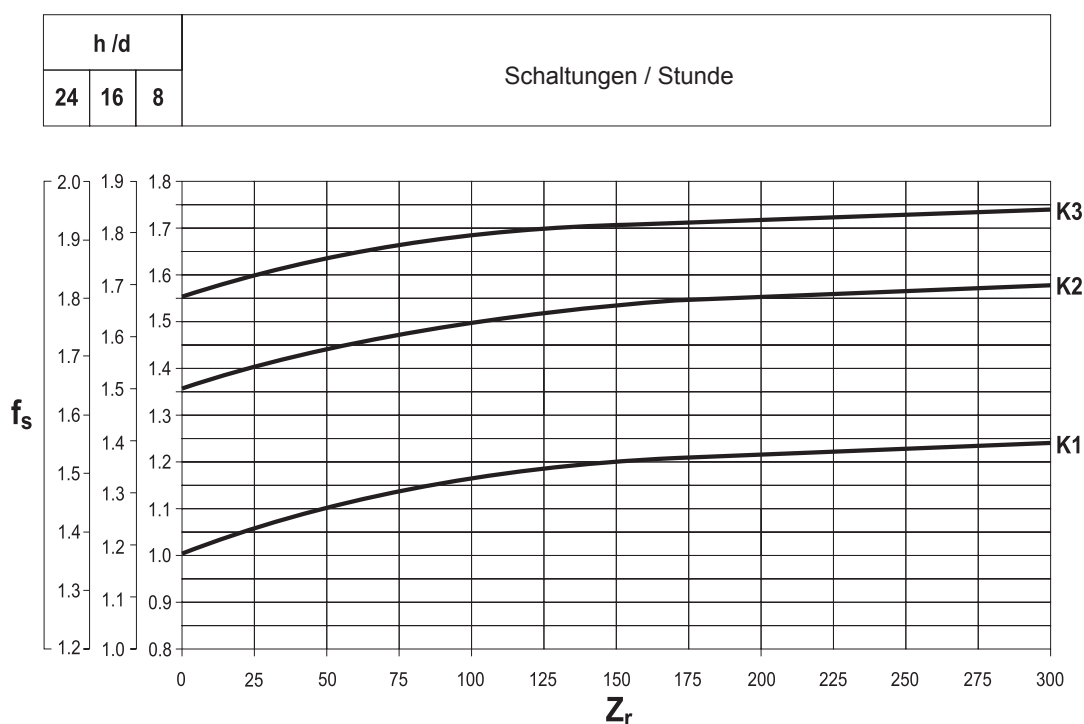

Beschleunigungsfaktor der Massen, [K]

Dieser Parameter dient der Wahl der Kurve, die sich auf die jeweilige Belastungsart bezieht. Der Wert ergibt sich aus folgender Formel:

$$K = \frac{J_c}{J_m} \quad (4)$$

$K = \frac{J_c}{J_m}$	→	$J_c =$ Trägheitsmoment der angetriebenen Massen, bezogen auf die Motorwelle
		$J_m =$ Trägheitsmoment des Motors

$K \leq 0,25$	→	K1	Gleichmäßige Belastung
$0,25 < K \leq 3$	→	K2	Belastung mit mäßigen Stößen
$3 < K \leq 10$	→	K3	Belastung mit starken Stößen
$K > 10$	→		sich mit unseren Technischen Kundendienst in Verbindung zu setzen



3 ZULÄSSIGE TEMPERATURGRENZEN

Symbol	Beschreibung / Bedingungen	Wert (*)	
		Synthetiköl	Mineralöl
t_a	Umgebungstemperatur		
$t_{au \text{ min}}$	Minimum Umgebungstemperatur bei Betrieb	-30°C	-10°C
$t_{au \text{ Max}}$	Maximum Umgebungstemperatur bei Betrieb	+50°C	+40°C
$t_{as \text{ min}}$	Minimum Umgebungstemperatur während Lagerung	-40°C	-10°C
$t_{as \text{ Max}}$	Maximum Umgebungstemperatur während Lagerung	+50°C	+50°C
t_s	Oberflächentemperatur		
$t_{s \text{ min}}$	Minimum Getriebeoberflächentemperatur beim Start unter Teillast (#)	-25°C	-10°C
$t_{sc \text{ min}}$	Minimum Getriebeoberflächentemperatur beim Start unter Volllast	-10°C	-5°C
$t_{s \text{ Max}}$	Maximum Gehäuseoberflächentemperatur während Dauerbetrieb (am Getriebeeingang gemessen)	+100°C	+100°C (@)
t_o	Öltemperatur		
$t_{o \text{ Max}}$	Maximum Öltemperatur während Dauerbetrieb	+95°C	+95°C (@)

(*) = Weitere Informationen gem. Tabelle "Auswahl der optimalen Ölviskosität" in Bezug auf min. und max. Werte bei unterschiedlichen Ölviskositäten. Für Werte von $t_a < -20^\circ\text{C}$ und $t_s > 80^\circ\text{C}$, müssen der Anwendung entsprechende Dichtwerkstoffe ausgewählt werden. Bei weiteren Fragen wenden Sie sich bitte an den Technischen Service von Bonfiglioli.

(@) = Dauerbetrieb ist nicht empfehlenswert bei t_s und t_o im Bereich von 80°C bis 95°C

(#) = Für einen Start unter Volllast wird eine Hochlauframpe empfohlen. Bei weiteren Fragen wenden Sie sich bitte an den Technischen Service von Bonfiglioli.



4 ANTRIEBSAUSWAHL

4.1 Wahl des Getriebemotors

- a) Stellen Sie Betriebsfaktor f_s fest, wie früher spezifiziert.
- b) Bestimmen sie die benötigte Leistung an der Getriebeeingangswelle.

$$P_{r1} = \frac{M_{r2} \times n_2}{9550 \times \eta_d} \quad [\text{kW}] \quad (5)$$

- c) Unter den Getriebemotoren-Auswahltabellen die Tabelle auswählen, die folgender Leistung P_n entspricht:

$$P_n \geq P_{r1} \quad (6)$$

Wenn nicht anders angegeben, bezieht sich die im Katalog angegebene Leistung P_n der Motoren auf Dauerbetrieb S1. Bei Motoren, die unter anderen Bedingungen als S1 eingesetzt werden, muß die vorgesehene Betriebsart unter Bezug auf die CEI-Normen 2-3/IEC 34-1 bestimmt werden. Insbesondere kann man für die Betriebsarten S2 bis S8 (und für Motorbaugrößen gleich oder niedriger als 132) eine Überdimensionierung der Leistung relativ zu der für den Dauerbetrieb vorgesehenen Leistung erhalten; die zu erfüllende Bedingung ist dann:

$$P_n \geq \frac{P_{r1}}{f_m} \quad (7)$$

Der Überdimensionierungsfaktor f_m kann der Tabelle entnommen werden.

Relative Einschaltdauer

$$I = \frac{t_f}{t_f + t_r} \times 100 \quad (8)$$

t_f = Betriebszeit mit konstanter Belastung

t_r = Aussetzzeit

	BETRIEB						
	S2			S3*			S4 - S8
	Zyklusdauer [min]			Relative Einschaltdauer (I)			Rückfrage
	10	30	60	25%	40%	70%	
f_m	1.35	1.15	1.05	1.25	1.15	1.1	

* Die Zyklusdauer muß in jedem Fall kleiner oder gleich 10 min sein; wenn sie darüber liegt, unseren Technisch en Kundendienst zu Rate ziehen.



Als nächstes wählen Sie anhand der Getriebemotoren auswahltabellen den Abschnitt mit der entsprechenden P_n und suchen die gewünschte Abtriebsdrehzahl n_2 , oder die nächstmögliche Drehzahl, zusammen mit dem Sicherheitsfaktor S , der den zutreffenden Betriebsfaktor f_s erreicht oder überschreitet.

$$S \geq f_s \quad (9)$$

Der Sicherheitsfaktor wird wie folgt berechnet:

$$S = \frac{M_{n2}}{M_2} = \frac{P_{n1}}{P_1} \quad (10)$$

Standardmäßig stehen Getriebemotorenkombinationen mit 2, 4 und 6 poligen Motoren für eine Frequenz von 50 Hz zur Verfügung. Sollten die Antriebsdrehzahlen abweichend von 2800, 1400 oder 900 min^{-1} sein, dann stützen Sie die Auslegung des Getriebes auf die Getriebeenddaten.

4.2 Wahl des Getriebes

a) Den Betriebsfaktor f_s bestimmen.

b) Bestimmen sie das Soll-Drehmoment M_{c2} :

$$M_{c2} = M_{r2} \times f_s \quad (11)$$

c) Bestimmen Sie die erforderliche Getriebeuntersetzung.

$$i = \frac{n_1}{n_2} \quad (12)$$

d) Beziehen Sie sich auf die Getriebe Auswahltabellen und bestimmen Sie eine Getriebegröße, dessen Nenndrehmoment bei der Antriebsdrehzahl n_1 und einer passenden Untersetzung $[i]$ folgende Bedingungen erfüllt:

$$M_{n2} \geq M_{c2} \quad (13)$$

Überprüfen Sie die Anbaumöglichkeit des gewählten Motors im Kapitel „Motor Anbaumöglichkeiten“.



5 PRÜFUNGEN

Nachdem die Auswahl des Getriebe oder Getriebemotor abgeschlossen ist, werden die folgenden Schritte empfohlen:

a) Max. Drehmoment

Im allgemeinen darf das max. Drehmoment (verstanden als momentane Lastspitze), das auf das Getriebe aufgebracht werden kann, 150 % des Nenndrehmoments M_{n2} nicht überschreiten. Nach Prüfung und Freigabe durch BONFIGLIOLI können auch kurzzeitig Spitzenmomente bis 300% zugelassen werden. Bei polumschaltbaren Drehstrommotoren muss dem Umschaltdrehmoment, das beim Umschalten von der hohen auf die niedrige Drehzahl erzeugt wird, besondere Aufmerksamkeit geschenkt werden, da es entschieden größer sein kann als das Nenn-Drehmoment. Eine einfache und kostengünstige Methode zum Senken dieses Drehmoments besteht darin, daß nur zwei Phasen des Motors während des Umschaltens gespeist werden (die Dauer der Speisung von nur 2 Phasen kann durch ein Zeitrelais gesteuert werden):

Umschaltdrehmoment	
$Mg_2 = 0.5 \times Mg_3$	
Mg_2	Umschaltdrehmoment bei Speisung von 2 Phasen
Mg_3	Umschaltdrehmoment bei Speisung von 3 Phasen

b) Radialkräfte

Sicherstellen, daß die auf die Antriebswellen und/oder Abtriebswellen wirkenden Radialkräfte innerhalb der zulässigen Katalogwerte liegen. Wenn sie höher sind, das Getriebe größer dimensionieren bzw. die Abstützung der Last verändern. Wir erinnern daran, daß alle im Katalog angegebenen Werte sich auf Kräfte beziehen, die auf die Mitte des Wellenendes wirken. Diese Tatsache muß bei der Prüfung unbedingt berücksichtigt werden und nötigenfalls muß mit Hilfe der geeigneten Formeln die zulässige Kraft beim gewünschten Abstand x bestimmt werden. Siehe hierzu die Erläuterungen zu den Radialkräften in diesem Katalog.

c) Axialkräfte

Auch die eventuell vorhandenen Axialkräfte müssen mit den im Katalog angegebenen zulässigen Werten verglichen werden. Wenn sehr hohe Axialkräfte wirken oder Axialkräfte in Kombination mit Radialkräften, bitte unseren Technischen Kundendienst zu Rate ziehen.

d) Schaltungen/Stunde

Bei anderen Betriebsarten als S1 mit einem hohen Wert für die Schaltungen/Stunde muß der Faktor Z berücksichtigt werden (er kann mit Hilfe der Angaben im Kapitel Motoren bestimmt werden), der die max. Zulässige Anzahl von Schalten für eine bestimmte Anwendung Definiert.

6 INSTALLATION

6.1 Allgemeine Eigenschaften

a) Sicherstellen, daß die Befestigung des Getriebes stabil ist, damit keine Schwingungen entstehen. Wenn es voraussichtlich zu Stößen, längerdauernden Überlasten oder zu Blockierungen kommen kann, sind entsprechende Schutzelemente wie hydraulische Kupplungen, Kupplungen, Rutschkupplungen usw. zu installieren.



- b) Beim Lackieren die bearbeiteten Flächen und die Dichtringe schützen, damit der Anstrichstoff nicht dem Kunststoff angreift und somit die Dichtigkeit der Ölabdichtungen in Frage gestellt wird.
- c) Die Organe, die mit einer Keilverbindung auf der Abtriebswelle des Getriebes befestigt werden, müssen mit einer Toleranz ISO H7 gearbeitet sein, um allzu fest blockierte Verbindungen zu vermeiden, die eventuell zu einer irreparablen Beschädigung des Getriebes während des Einbaus führen könnten. Außerdem sind beim Ein- und Ausbau dieser Organe geeignete Zugstangen und Abzieher zu verwenden, wobei die Gewindebohrung an den Köpfen der Wellen zu verwenden ist.
- d) Die Berührungsflächen müssen sauber sein und vor der Montage mit einem geeigneten Schutzmittel behandelt werden, um Oxidierung und die daraus folgende Blockierung der Teile zu verhindern.
- e) Bevor das Getriebe in Betrieb zu setzen, muß man sich vergewissern daß die das Getriebe einbauende Maschine gemäß den aktuellen Regelungen der Maschine Richtlinie 2006/42/CE ist.
- f) Vor Inbetriebnahme der Maschine sicherstellen, daß die Anordnung der Füllstandschaube der Einbaulage angemessen ist, und die Viskosität des Schmiermittels der entspricht.
- g) Bei Inbetriebnahme in Frein, muß man geeigneten Schutzgeräte vorsehen, um das Antrieb gegen Regen und direkte Sonnenstrahlung zu schützen.

6.2 Inbetriebnahme der W-Getriebe

Die Getriebeeinheiten W63, W75 und W86 werden für Transportzwecke mit einem Blindstopfen im seitlichen Deckel ausgeliefert. Vor der Inbetriebnahme muss dieser Stopfen durch einen Lüfter, ausgetauscht werden. Siehe nachfolgende Abbildung.

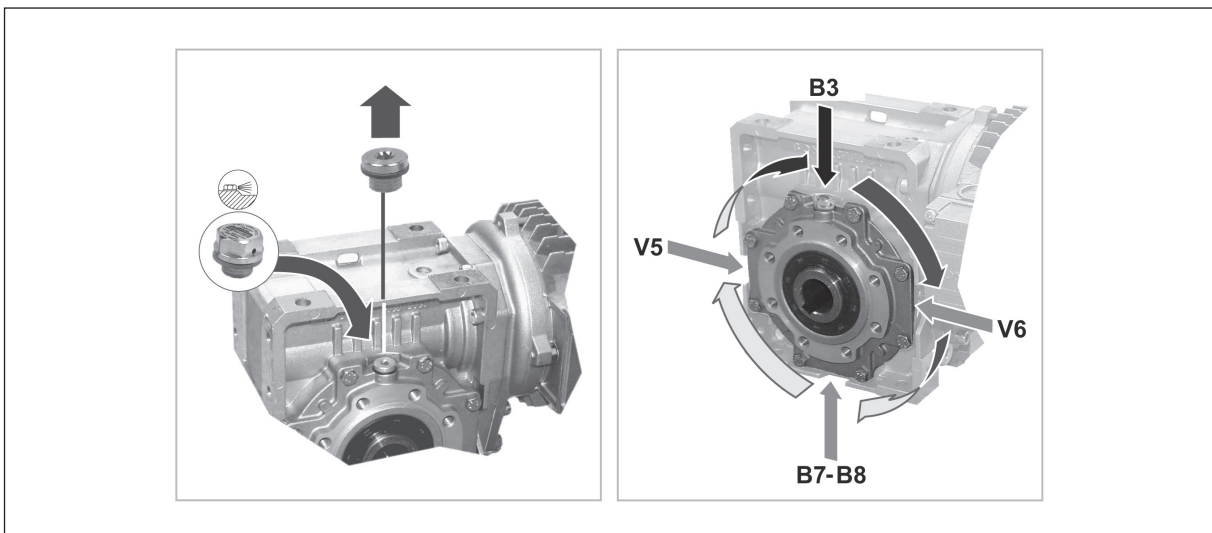

Bei der Ausrichtung B6 darf dieser Blindstopfen jedoch NICHT durch die Entlüftungsschraube ersetzt werden.



7 SCHMIERUNG

Die mit Dauerschmierung gelieferten Getriebe benötigen einen periodischen Ölwechsel. Weitere Informationen in Bezug auf Wartungsintervalle, Ölstandskontrolle und Wechsel gem. Benutzerhandbuch unter www.Bonfiglioli.com
Mineralöl und Synthetiköl und/oder Öl von unterschiedlichen Herstellern darf nicht gemischt werden. Es sollte jedoch bei Aussetzbetrieb einmal monatlich und bei Dauerbetrieb häufiger der Ölstand kontrolliert werden. Falls notwendig, Öl nachfüllen.

7.1 Auswahl der optimalen Ölviskosität (Daten basierend auf Shell Ölen)

		Umgebungstemperatur während Betrieb [C°]																				
		-40	-35	-30	-25	-20	-15	-10	-5	0	+5	+10	+15	+20	+25	+30	+35	+40	+45	+50		
Tauchschmierung	Synthetiköl (PAG)	150 VG	☐	☐	*	*															☎	
		220 VG	☐	☐		*	*															
		320 VG [1]	☎	☐		*																
		460 VG [2]					*															

☐ Empfohlene Grenzbetriebsdaten.

☎ Zulässige Grenzbetriebsdaten. ☎

☐ Unzulässige Grenzbetriebsdaten.

* = Eine Hochlauframpe wird empfohlen. Bei weiteren Fragen wenden Sie sich bitte an den Technischen Service von Bonfiglioli. ☎

[1] Viskosität 320 wird für VF - VFR - VF_EP - W - WR - W_EP Untersetzungsgetriebe empfohlen. Wenden Sie sich bei anderen Anforderungen an den technischen Kundendienst von Bonfiglioli.

[2] Für VFL - WL Untersetzungsgetriebe ist die Verwendung der Viskosität 460 zwingend erforderlich.

7.2 Schmierung der Getriebe der serie W und VF

Die Getriebegrößen VF 27 ... VF 49, W 63 ... W 86 sind bei der Lieferung ab Werk bzw. ab offiziellem Verkaufnetz mit einer synthetischen "Long-Life" -Dauerschmierung versehen. Auf Anfrage können die oben benannten Einheiten auch ohne Öl geliefert werden. Hier muss bei der Bestellung die Option **SO** angegeben werden. Die Anwendbarkeit der Option wird im Kapitel „GETRIEBE OPTIONEN“ näher erläutert. Falls nicht anders spezifiziert werden die Getriebe VF 130 ... VF 250 und W 110 grundsätzlich ohne Öfüllung ausgeliefert. Vor der Inbetriebnahme muss das Getriebe kundenseitig mit der richtigen Öfüllmenge befüllt werden. Sollten Sie diese Getriebe mit der Option **LO** bestellen, werden die Einheiten direkt vom Werk aus mit synthetischem Öl, gemäß der spezifizierten Einbaulage, befüllt. Die Anwendbarkeit der Option wird im Kapitel „GETRIEBE OPTIONEN“ näher erläutert. Doppelschneckengetriebe Typ VF/VF, VF/W und W/VF bestehen aus zwei separaten Einheiten mit eigenen Öfüllungen. Hinsichtlich der Bezugsübersichten mit der Einbaulage der Serviceschrauben/ Stopfen und den Angaben zu den Schmierstoffmengen bitte die Betriebs- und Wartungsanleitung einsehen (auf www.bonfiglioli.com verfügbar). Die mit Lebensdauerschmierung gelieferten Getriebe sind mit synthetischem Öl auf Polyglykolbasis befüllt. Sollte das Öl nicht durch äußere Einwirkungen verunreinigt werden, benötigt das Getriebe über die gesamte Lebensdauer keinen Ölwechsel.



8 LAGERUNG

Die korrekte Lagerung der Antriebe erfordert folgende Vorkehrungen:

a) Die Produkte nicht im Freien lagern und nicht in Räumen, die der Witterung ausgesetzt sind, oder eine hohe Feuchtigkeit aufweisen.

b) Die Produkte nie direkt auf dem Boden, sondern auf Unterlagen aus Holz oder einem anderen Material lagern.

c) Bei anhaltenden Lager- und Haltszeiten müssen die Oberflächen für die Verbindung, wie Flansche, Wellen oder Kupplungen mit einem geeigneten Oxidationsschutzmittel behandelt werden (Mobilarma 248 oder ein äquivalentes Mittel).

Übrigens müssen die Getriebe mit nach oben gerichteter Entlüftungsschraube gelagert und mit Öl gefüllt werden.

Die Getriebe müssen vor ihrer Verwendung mit der angegebenen Menge des vorgesehenen Schmiermittels gefüllt werden.

9 LIEFERBEDINGUNGEN

Die Getriebe werden in folgendem Zustand geliefert:

a) schon bereit für die Montage in der bei Bestellung festgelegten Einbaulage;

b) nach werksinternen Spezifikationen Geprüft;

c) die Verbindungsflächen sind nicht lackiert;

d) ausgestattet mit Schrauben und Muttern für die Montage der Motoren (Version mit Adapter für IEC-Motoren);

e) alle Getriebe werden mit Kunststoffschutz auf den Wellen geliefert;

f) mit Transportriering zum Anheben (falls vorgesehen).

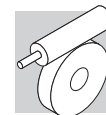

SCHNECKENGETRIEBE

10 KONSTRUKTIVE EIGENSCHAFTEN

10.1 Charakteristische Eigenschaften aller Bonfiglioli Schnecken-getriebe

- Symmetrische Hohlwellen ermöglichen eine Montage der Getriebe und der Einsteckwellen (nur als Service-Kit) auf beiden Seiten.
- Geschliffene Schneckenwellen und ihre präzise Bearbeitung ermöglichen einen hohen Wirkungsgrad und extrem niedrige Betriebsgeräusche.
- Zahlreiche Produkt-konfigurationen erlauben eine Motage über Fuß-, Flansch- oder Wellenbefestigung. Drehmoment-stützen können optional geliefert werden.
- Durch zusätzliche Optionen lassen sich die Antriebe an unterschiedliche Anwendungen anpassen.

10.2 Charakteristische Eigenschaften der VF - Serie

- Aluminium Druckguss Gehäuse für die Baugrößen: VF27, VF30, VF44 und VF49. Robuster Stahlguss für die Baugrößen: VF130 bis VF250. Wobei die letztere Gruppe mit einem Wärmehärtenden epoxyd Pulver überzogen werden.

10.3 Charakteristische Eigenschaften der W-Serie

- Monoblockgehäuse aus Aluminium
- Die kubische Form des Getriebegehäuses und die bearbeiteten Flächen aller Gehäusesseiten verleihen den Getrieben eine extreme Flexibilität bei der Montage. Durch zusätzliche Bauteile wird diese Flexibilität erweitert.
- Die Getriebe mit integrierten Motoren bauen sehr kompakt, haben geringe Gewichte und sind sehr preiswert.
- Die Wellendichtringe an der Eingangswelle der Baugrößen: W63, W75 und W86 sind aus Fluor-Elastomer und im Gehäuse integriert. Dies erhöht die Haltbarkeit und verlängerte die Lebensdauer.

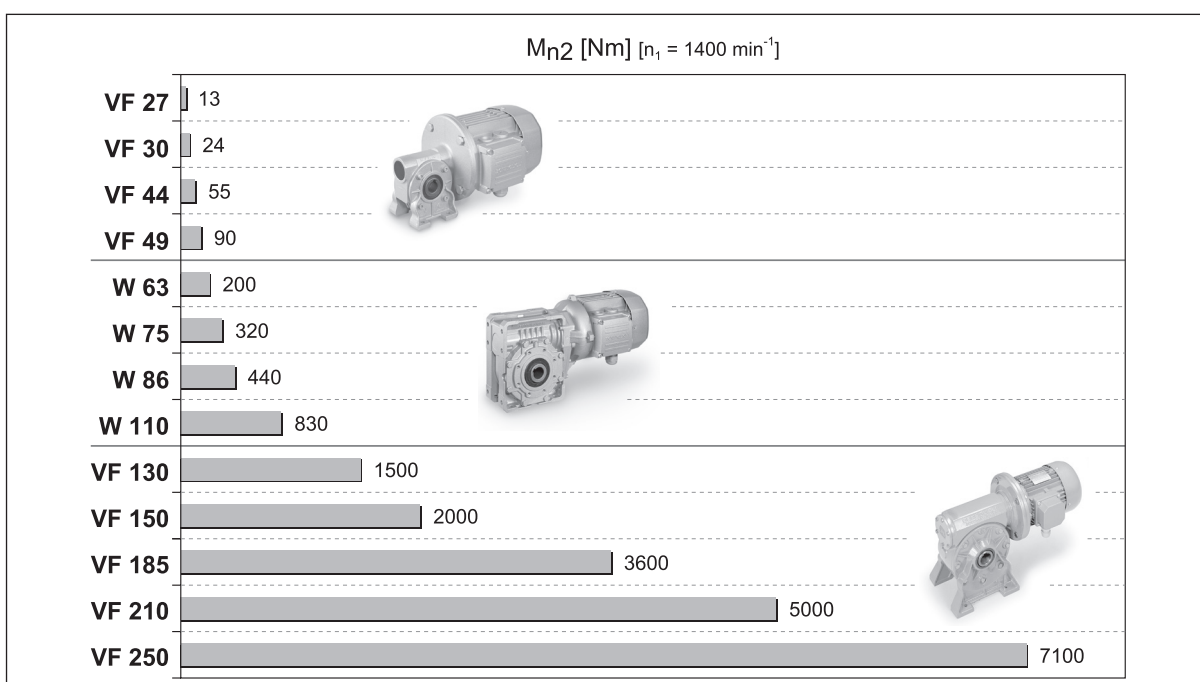

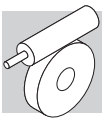

11 BAUFORMEN

VF_		W_	
		N VF 27 ... VF 250	 U W 63 ... W 110 Universalgehäuse
		A VF 27 ... VF 250	
		V VF 27 ... VF 250	 UF W 63 ... W 110 Standardanbaufansch
		F VF 27 ... VF 185	
		FA VF 44 ... VF 49	
		FC VF 130 ... VF 185	 UFC W 63 ... W 110 Kurzer Anbaufansch
		FR VF 130 ... VF 185	
		P VF 30 ... VF 250	
		U VF 30 ... VF 49	 UF W 75 Verkürzter Anbaufansch in Länge und Durchmesser
		FA VF 44 ... VF 49	
		FC VF 130 ... VF 185	
		FR VF 130 ... VF 185	
		P VF 30 ... VF 250	
		U VF 30 ... VF 49	

Bei kombinierten Getrieben VF / VF, VF / W und W / VF beziehen sich die Ausführungen auf das zweite Getriebe (Maschinenseitig).

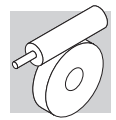

12 BAUFORM

Bei Doppelschneckengetrieben werden, wenn nicht anders in der Bestellung spezifiziert, die grau hinterlegten Konfigurationen aus der nachstehenden Tabelle im Werk montiert.

	CW1	CCW1	CW2	CCW2	CW3	CCW3	CW4	CCW4
U								
UF_ UFC_ UFR1_								
N								
A								
V								
F1 FA1 FC1 FR1								
F2 FA2 FC2 FR2								
P1								
P2								

Deckel für Aufsteckmontage

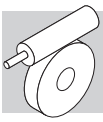

Bei der Ausführung HS (Getriebe) sind alle abgebildeten Montageausführungen möglich.
Bei der Ausführung P (IEC) können bestimmte Montageausführungen nur durch Verwendung von IEC-Flanschen (B5 oder B14) erreicht werden, die gleich groß oder kleiner als die in den folgende Tabelle angegebenen sind.

		CW1 CCW1	CW2 CCW2	CW3	CCW3	CW4 CCW4
VF/VF30/44	A, N, V, P1 F-FA,U	63B14	63B14	63B14	63B14	63B14
VF/VF30/49	A, N, V, P1, F-FA,U	63B14	63B14	63B14	63B14	63B14
VF/W30/63	U, UF-UFC	63B5-63B14	63B5-63B14	63B5-63B14	63B5-63B14	63B5-63B14
VF/W44/75	U, UF-UFC-UFCR	71B5-71B14	71B5-71B14	71B5-71B14	71B5-71B14	71B5-71B14
VF/W44/86	U, UF-UFC	71B5-71B14	71B5-71B14	71B5-71B14	71B5-71B14	71B5-71B14
VF/W49/110	U, UF-UFC	80B5-80B14	80B5-80B14	80B5-80B14	80B5-80B14	80B5-80B14
W/VF63/130	N	71B5-90B14	90B5-90B14	71B5-90B14	71B5-90B14	71B5-90B14
	A	90B5-90B14	71B5-90B14	90B5-90B14	90B5-90B14	90B5-90B14
	V		90B5-90B14			—
	F1	90B5-90B14	71B5-90B14	90B5-90B14	71B5-90B14	90B5-90B14
	FC1-FR1				90B5-90B14	
	P1				90B5-90B14	
	F2	90B5-90B14	71B5-90B14	71B5-90B14	90B5-90B14	90B5-90B14
	FC2-FR2			90B5-90B14		
P2			90B5-90B14			
W/VF86/150	N	112B5-112B14	112B5-112B14	71B5-112B14	71B5-112B14	71B5-112B14
	A	112B5-112B14	90B5-112B14	112B5-112B14	112B5-112B14	112B5-112B14
	V	112B5-90B14	112B5-90B14			71B5-112B14
	F1	112B5-112B14	71B5-90B14	112B5-112B14	71B5-90B14	112B5-112B14
	FC1-FR1		90B5-112B14		112B5-112B14	
	P1		90B5-112B14		112B5-112B14	
	F2	112B5-112B14	71B5-90B14	71B5-90B14	112B5-112B14	112B5-112B14
	FC2-FR2		90B5-112B14	112B5-112B14		
P2			112B5-112B14			
W/VF86/185	N	112B5-112B14	112B5-112B14	90B5-112B14	90B5-112B14	90B5-112B14
	A	90B5-112B14	112B5-112B14	112B5-112B14	112B5-112B14	112B5-112B14
	V	112B5-90B14				90B5-112B14
	F1	112B5-112B14	90B5-112B14	112B5-112B14	90B5-112B14	112B5-112B14
	FC1-FR1				112B5-112B14	
	P1				112B5-112B14	
	F2	112B5-112B14	90B5-112B14	90B5-112B14	112B5-112B14	112B5-112B14
	FC2-FR2			112B5-112B14		
P2			112B5-112B14			
VF/VF130/210	N	#	132B5	#	#	#
	A	132B5	#	132B5	132B5	132B5
	V					
	P					
VF/VF130/250	N	#	132B5	#	#	#
	A	132B5	#	132B5	132B5	132B5
	V		132B5			
	P		#			

Bitte nehmen Sie mit unserem Technischen Verkaufsdienst Kontakt auf

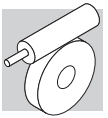

12.1 Ausrichtung des Klemmenkastens

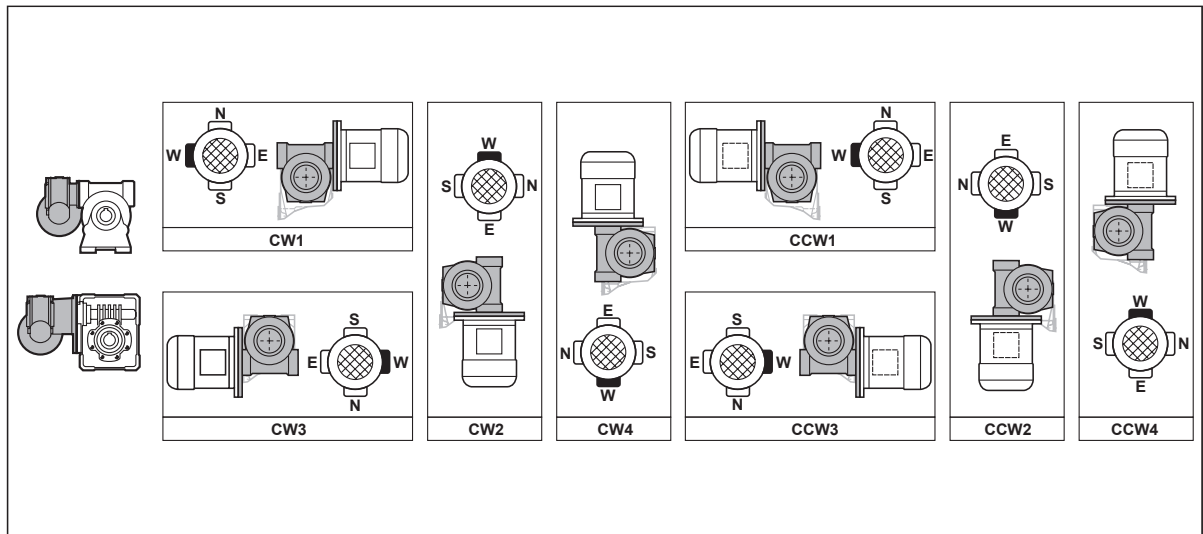



13 BEZEICHNUNG

GETRIEBE

W 63 L1 UF1 — 24 S2 — B3

OPTIONEN

BAUFORM

VF/VF, VF/W, W/VF	CW (1, 2, 3, 4) CCW (1, 2, 3, 4)
-------------------	---





















EINBAULAGEN

VF 27...VF 49 VFR 44, VFR 49	B3
W, WR VF 130...VF 250 VFR 130...VFR 250	B3 (default), B6, B7, B8, V5, V6
VF/VF VF/W W/VF	 B3 (default), B6, B7, B8, V5, V6

IEC MOTOR BAUFORM

B5	(VF 30...VF 250, VFR 49...VFR 250, W, WR)
B14	(VF 30...VF 49, W)

BEZEICHNUNG DER ANTRIEBSSEITE

	VF	VFR	W	WR	VF/VF	VF/W	W/VF
P(IEC)	 P27 (VF 27 only), P56...P225	 P63, P80...P160	 P71...P132	 P63...P112	 P56, P63, P90...P132	 P56...P80	 P71...P112
S_		 S44 (VFR 44 only)	 S1...S3 S10...S30				 S1...S3 S10...S30
HS							

ÜBERSETZUNG

ABTRIEBSWELLEDURCHMESSER

W 75 VF/W 44/75	D30 (default), D28 (Option)
--------------------	------------------------------------

BAUFORM

RUTSCHKUPPLUNG

VF, VFR W, WR	L1, L2	VF/VF	LF
------------------	---------------	-------	-----------

GETRIEBEBAUGRÖSSE

VF	27, 30, 44, 49, 130, 150, 185, 210, 250	VF/VF	30/44, 30/49, 130/210, 130/250
VFR	44, 49, 130, 150, 185, 210, 250	VF/W	30/63, 44/75, 44/86, 49/110
W, WR	63, 75, 86, 110	W/VF	63/130, 86/150, 86/185

GETRIEBE TYP

VF, W	Schneckengetriebe
VFR, WR	Schneckengetriebe mit Vorstufe
VF/VF, VF/W, W/VF	Doppelschneckengetriebe



MOTOR

BREMSE

BN 63A 4 230/400-50 IP54 CLF W FD 3.5 R SB 220 SA

OPTIONEN

BREMSVERSORGUNG

GLEICHRICHTERTYP
AC/DC
NB, SB, NBR, SBRBREMSHANDLÜFTUNG
R, RM

BREMSMOMENT

BREMENTYP
FD (G.S. Bremse)
FA (W.S. Bremse)KLEMMKASTENLAGE
W (default), **N, E, S**BAUFORM
— (Kompaktmotor)
B5, B14 (IEC - Motor)ISOLIERUNGSKLASSE
CL F Standard
CL H OptionSCHUTZART
IP55 Standard (IP54 - Bremssmotor)

SPANNUNG - FREQUENZ

POLZAHL
2, 4, 6, 2/4, 2/6, 2/8, 2/12, 4/6, 4/8MOTOR-BAUGRÖSSE
1SC ... 3LB (Kompaktmotor)
56A ... 180L (IEC - Motor) BN 27, BN 44 (Spezialmotoren)

MOTORTYP

MX - MXN = Dreiphasen Kompaktmotor,
Klasse IE3**BX - BXN** = Dreiphasen IEC Motor,
Klasse IE3**ME** = Dreiphasen Kompaktmotor,
Klasse IE2**BE** = Dreiphasen IEC Motor,
Klasse IE2**M** = Dreiphasen Kompaktmotor,
Klasse IE1**BN** = Dreiphasen IEC Motor,
Klasse IE1





14 GETRIEBE OPTIONEN

SCHMIERUNG

Die Getriebe VF 27, VF 30, VF 44, VF 49 und W 63, W 75, W 86 sind in der Regel werkseitig in der Standardausführung mit Öl befüllt. Die Getriebe VF 130, VF 150, VF 185, VF 210, VF 250 und W 110 werden standardmäßig ungeschmiert geliefert.

Für alle werkseitig mit Öl gefüllten Getriebegrößen ist es jedoch möglich, die Lieferung mit weiteren Ölarten anzufordern, die gemäß den Definitionen in der Tabelle (LUB. 01) ausgewählt werden können. Die Anwendbarkeit der Option SCHMIERUNG ist in der Tabelle (LUB. 02) beschrieben.

(LUB. 01)

SCHMIERUNG	Typ	Bezeichnung	Hersteller
LH	Polyglykol (PAG)	OMALA S4 WE 150	
LS	Polyglykol (PAG)	OMALA S4 WE 220	
LO* [1]	Polyglykol (PAG)	OMALA S4 WE 320	
LK [2]	Polyglykol (PAG)	OMALA S4 WE 460	
LA	Lebensmittelverwendung	KLUBERSYNTH UH1 6-150	
LB	Lebensmittelverwendung	KLUBERSYNTH UH1 6-220	
LC [1]	Lebensmittelverwendung	KLUBERSYNTH UH1 6-320	
LD [2]	Lebensmittelverwendung	KLUBERSYNTH UH1 6-460	

* Sofern nicht anders angegeben, verwenden die Getriebe VF 27, VF 30, VF 44, VF 49 und W 63, W 75, W 86 die mit einer „Lebensdauer“-Schmierfüllung geliefert werden, OMALA S4 WE 320-Öl.

[1] Empfohlener Einsatz für Getriebe vom Typ VF, VFR, VF_EP, W, WR, W_EP.

[2] Obligatorische Verwendung für Getriebe vom Typ VFL, WL.

(LUB. 02)

	SCHMIERUNG					
	Einbaulagen					
	B3	B6	B7	B8	V5	V6
W 110 U-UF-UFC	X	X	X	X	⊖	⊖
VF 130 A-N-P-F-FC	X	X	X	X	⊖	⊖
VF 130 V	⊖	X	X	⊖	X	X
VF 130 FR	X	⊖	⊖	X	⊖	⊖
VF 150 A-N-P-F-FC	X	X	X	X	⊖	⊖
VF 150 V	⊖	X	X	⊖	X	X
VF 150 FR	X	⊖	⊖	X	⊖	⊖
VF 185 A-N-P-F-FC	X	X	X	X	⊖	⊖
VF 185 V	⊖	X	X	⊖	X	X
VF 185 FR	X	⊖	⊖	X	⊖	⊖
VF 210 A-N-P	X	⊖	⊖	X	⊖	⊖
VF 210 V	⊖	⊖	⊖	⊖	X	X
VF 250 A-N-P	X	⊖	⊖	X	⊖	⊖
VF 250 V	⊖	⊖	⊖	⊖	X	X

SO

Die Getriebetypen VF 27 ... VF 49, W 63 ... W 86, das normalerweise sind mit Schmiermittel geliefert, werden ohne Öl geliefert.

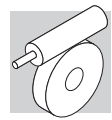

RB

Zweites Wellenende gegenüber von Eingangswelle (außer VF 27).

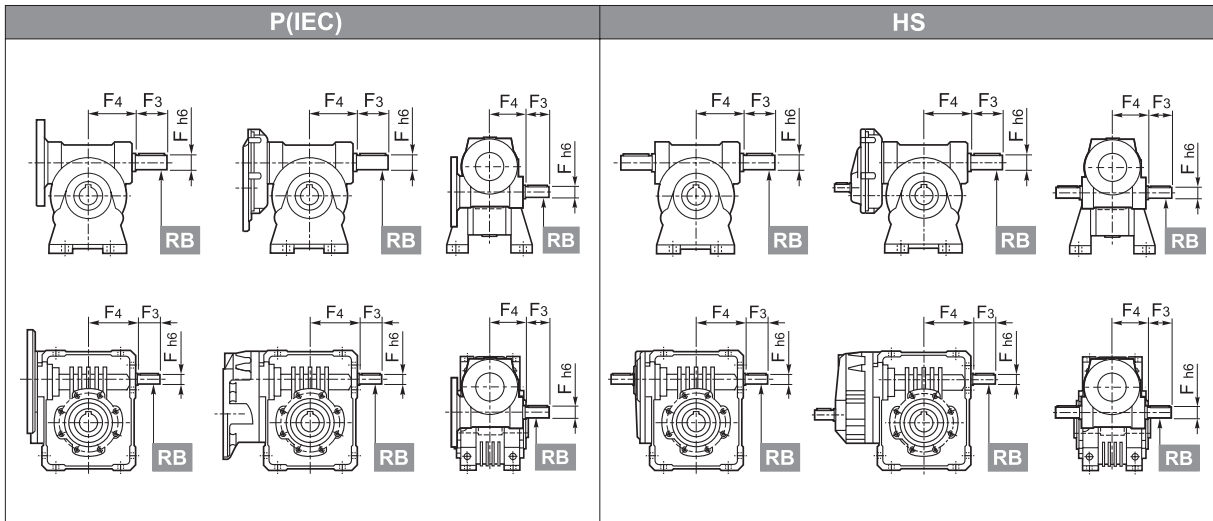

RBO

Zusätzliches Schneckenwellenende am 2. Getriebe (nur bei Doppelschneckengetrieben).

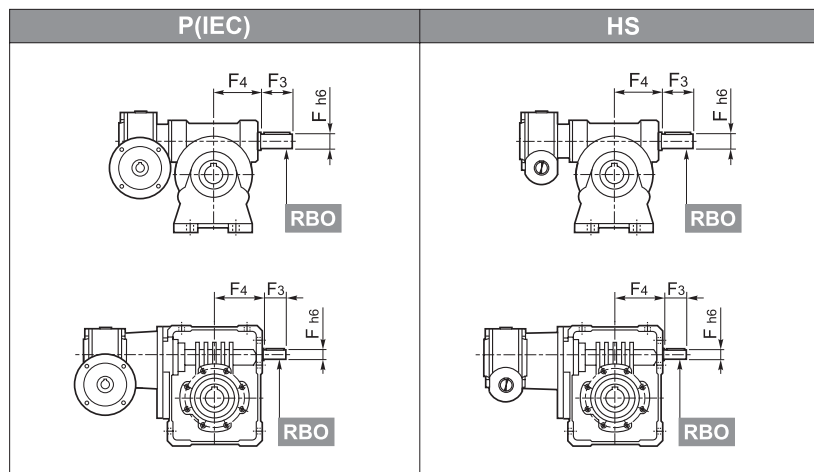

Abmessungen für frei hervorstehende welle (optionen RB und RBO)

		F	F ₁	F ₂	F ₃	F ₄	V
	VF	30	9	10.2	3	20	—
	VFR	44	11	12.5	4	30	—
	VF/VF	49	16	18	5	40	M6
		63	18	20.5	6	40	M6
	W	75	19	21.5	6	40	M6
	WR	86	25	28	8	50	M8
	VF/W	110	25	28	8	60	M8
		130	30	33	8	60	M8
	VF	150	35	38	10	65	M8
	VFR	185	40	43	12	70	M8
	W/VF	210	48	51.5	14	82	M16x40
		250	55	59	16	82	M16x40

Für VF 210-250, in den Baumodellen **A** und **P**, wird in der Regel ein Kühlungsgebläse montiert; mit der Option **RB** kann dieses nicht montiert werden

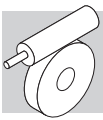

VV

Wellendichtringe aus Fluor-Elastomer auf der Antriebswelle. Lieferbar für W110 und für die VF-Reihe. Ausschließlich VF 30 nach Ausführung RB und/oder HS.

PV

Alle Wellendichtringe aus Fluor-Elastomer. Ausschließlich VF 30 nach Ausführung RB und/oder HS .

KA

Durch mit VF_A austauschbarem Satz - Abstellfüße komplettiert.

KV

VF_V Austauschbarkeit Kit (mit Ausnahme von W mit der RB Option und W 110 in B6 Einbaulage). Die Option ist verfügbar für W 63 bis W 110 Einheiten.

AO

Abtriebswelle auf die Gegenseite als Standard (VF 27).

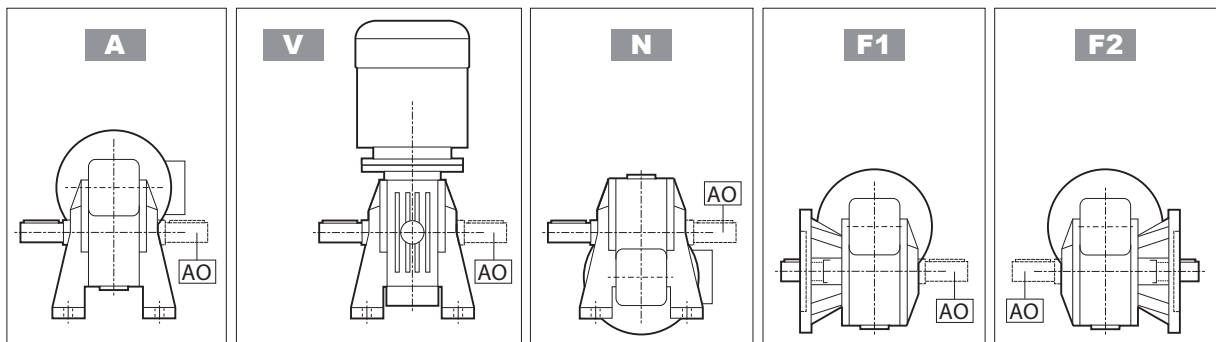

BP

Getriebe, die normalerweise mit offener Entlüftungsschraube geliefert werden, werden mit einer Ventilentlüftungsschraube geliefert. Die Kalibrierung des Ventils kann je nach Steckertyp zwischen 0,10 und 0,15 bar variieren. Das Ventil öffnet in Intervallen und ermöglicht die Entlüftung des Innendrucks, wodurch Fremdkörper ferngehalten werden. Informationen zur Verfügbarkeit von Optionen finden Sie im Kapitel „Montagepositionen und Wartungsstecker“ des Installations-, Betriebs- und Wartungshandbuchs (verfügbar unter: www.bonfiglioli.com).

Wenden Sie sich bei Bedarf an den technischen Kundendienst von Bonfiglioli.

DREHMOMENTARM

Die Getriebe VF 30...VF 250 und W 63...W 110 werden mit montierter Drehmomentstütze geliefert. Es ist möglich, die Drehmomentstütze wie gezeigt an mehreren Positionen montiert anzufordern (TA1, TA2, TA1B, TA2B, TA1D, TA2D).

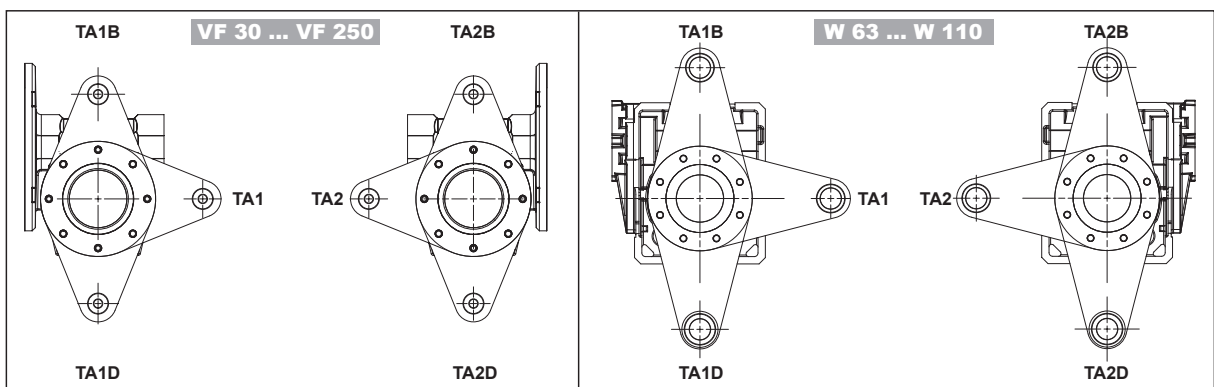



Die Anwendbarkeit der Option REAKTIONSBARM wird in der folgenden Tabelle beschrieben.

		REAKTIONSBARM	
		TA1 - TA1B - TA1D	TA2 - TA2B - TA2D
VF VFR VF/VF W/VF	VF 30 ... VF 49 F1	⊖	X
	VF 30 ... VF 49 F2	X	⊖
	VF 44 - VF 49 FA1	⊖	X
	VF 44 - VF 49 FA2	X	⊖
	VF 30 ... VF 49 P1	X	X
	VF 210 - VF 250 P1	X	X
	VF 130 ... VF 185 P1	X	⊖
W WR VF/W	VF 130 ... VF 185 P2	⊖	X
	W 63 ... W 110 U	X	X
	W 63 ... W 110 UF1 - UFC1	⊖	X
	W 63 ... W 110 UF2 - UFC2	X	⊖
	W 75 UFCR1	⊖	X
	W 75 UFCR2	X	⊖

Bei den Getrieben VFL - WL kann die Option nicht auf der Seite montiert werden, auf der der Drehmomentbegrenzer vorgesehen ist. Die Option ist nicht mit der SCHUTZKAPPE kompatibel, wenn sie auf der gleichen Seite vorgesehen ist.

SCHUTZKAPPE

Die Getriebe W-WR 63-75-86-110 werden mit einer Schutzkappe für die Abtriebsachse (aus Kunststoff) geliefert.

Es ist möglich, die Drehmomentstütze an mehreren Positionen wie gezeigt zu montieren (SC1, SC2).

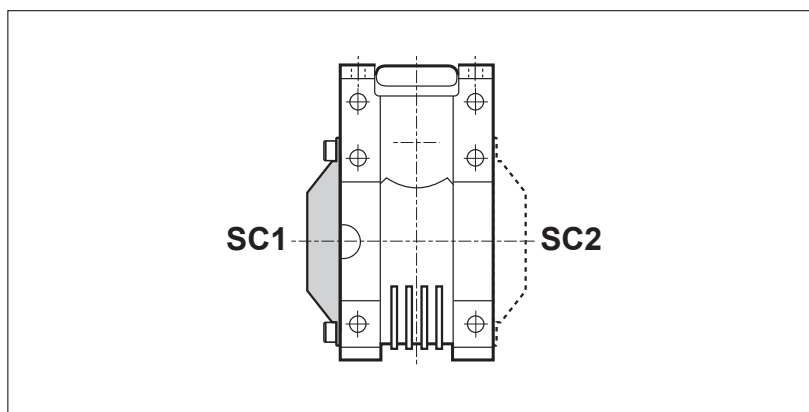

Die Anwendbarkeit der Option SCHUTZKAPPE ist in der folgenden Tabelle beschrieben.

		SCHUTZKAPPE	
		SC1	SC2
W WR VF/W	W 63 ... W 110 U	X	X
	W 63 ... W 110 UF1 - UFC1	⊖	X
	W 63 ... W 110 UF2 - UFC2	X	⊖
	W 75 UFCR1	⊖	X
	W 75 UFCR2	X	⊖

Bei den Getrieben VFL - WL kann die Option nicht auf der Seite montiert werden, auf der der Drehmomentbegrenzer vorgesehen ist. Die Option ist nicht mit dem DREHMOMENTARM kompatibel, wenn dieser auf derselben Seite vorhanden ist.

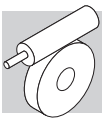

OBERFLÄCHENSCHUTZ

Wenn keine besondere Korrosionsschutzklasse gefordert ist, ist die lackierte Oberfläche des Getriebes mindestens mit einem Schutz gegen Korrosion der Klasse C2 nach UNI EN ISO 12944-2 geschützt. Für eine bessere Witterungsbeständigkeit können die Getriebe, durch eine Lackierung des ganzen Getriebes, mit einem Oberflächenschutz der Klassen **C3** und **C4** geliefert werden.

PROTEZIONE SUPERFICIALE	Ambienti tipici	Temperatura superficiale max.	Classe di corrosività secondo UNI EN ISO 12944-2
C3	Ambienti urbani ed industriali, con umidità relativa dell'aria max.100% (inquinamento ambientale medio)	120°C	C3
C4	Aree industriali, zone costiere, impianti chimici, con umidità relativa dell'aria max.100% (inquinamento ambientale alto)	120°C	C4

Getriebe mit einem optionalen Korrosionsschutz der Klassen **C3** oder **C4** sind in einer Auswahl von Farben verfügbar. Wenn keine spezielle Farbe gefordert ist, (siehe Option „Lackierung“) ist der Decklack in RAL 7042. Unsere Getriebe können auch mit Oberflächenschutz der Klasse **C5** nach UNI EN ISO 12944-2 versehen werden. Für weitere technische Informationen wenden Sie bitte an unseren Technischen Service.

LACKIERUNG

Getriebe mit Oberflächenschutz der Klasse C3 oder C4, sind in den, in der folgenden Liste aufgelisteten Farben, verfügbar.

VERNICIATURA	Colore	Catalogazione RAL
RAL7042*	Grigio traffico A	7042
RAL5010	Blu genziana	5010
RAL9005	Nero intenso	9005
RAL9006	Alluminio brillante	9006
RAL9010	Bianco puro	9010
RAL7035	Grigio chiaro	7035
RAL7001	Grigio argento	7001
RAL5015	Blu cielo	5015
RAL7037	Grigio polvere	7037
RAL5024	Blu pastello	5024

* Colore di fornitura standard se non specificato diversamente

Hinweis – Die Option „Lackierung“ kann nur im Zusammenhang mit dem Oberflächenschutz spezifiziert werden.

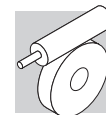

NACHWEISE

AC - Konformitätsbescheinigung Dokument mit dessen Ausstellung die Konformität des Produkts mit dem Auftrag, und dessen Konstruktion in Konformität mit den vom Qualitätsmanagementsystem von Bonfiglioli Riduttori vorgesehenen Standardfertigungs- und -kontrollverfahren bescheinigt wird.

CC – Prüfzeugnis

Die Bestellung führt zur Durchführung von Kontrollen der Konformität mit dem Auftrag, allgemeinen Sichtkontrollen und instrumentalen Prüfungen der Passmaße. Des Weiteren werden allgemeine Betriebskontrollen bei Leerlauf sowie Prüfungen der Funktionalität der Dichtungen bei Stillstand und während des Betriebs durchgeführt. Die Prüfung wird anhand einer Stichprobe des Versandloses durchgeführt.

Optionen Motoren

Detaillierte Informationen entnehmen Sie bitte dem Kapitel "Elektromotoren".

15 EINBAULAGEN UND LAGE DES KLEMMENKASTENS

Die Angaben zur Lage des Klemmenkastens beziehen sich auf das von der Lüfterseite her betrachtete Getriebe. Die Standardorientierung ist schwarz hervorgehoben (W).

Die in der Tabelle dargestellten Positionen auf der Klemmenleiste sind nicht für VFR 44 gültig. Für die Zuordnung und die Identifizierung der Bauform ist Bezug auf die Seiten 21 und 112-113 zu nehmen.

Winkellage des Handlüfterhebels.

Bei Bremsmotoren wird der Handlüfterhebel (auf Anfrage) standardmäßig auf 90° gegenüber des Klemmkastens (AB-Anordnung) geliefert; wird eine andere Anordnung verlangt, muß dies bei der Bestellung durch das geeignete Option angegeben werden.

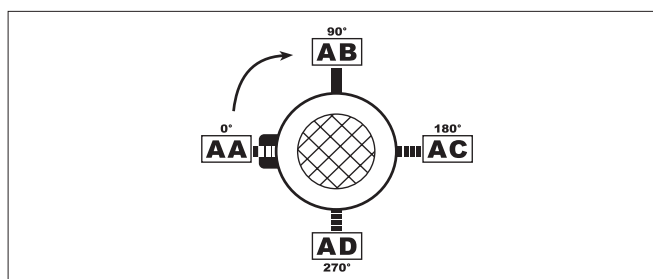

Auf den nachfolgenden Seiten sind die Einbaulagen der Getriebetypen VF und W beschrieben.

Für die kombinierten Getriebe der Typen VF/VF, VF/W und W/VF beziehen sich die Einbaulagen auf das zweite Getriebe (Maschinenseite); hinsichtlich des ersten Getriebes (Antriebsseite) ist auf das Kapitel "Ausführung des Einbaus" Bezug zu nehmen.

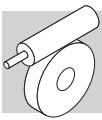

VF 27 _ ... VF 49 _

VFR 44 _ , VFR 49 _

_HS

_S - _P (IEC)

	_HS			_S - _P (IEC)		
A	B3	B7	V5			VF
	B6	B8	V6			VFR*
N	B3	B7	V5			VF
	B6	B8	V6			VFR*
V	B3	B7	V5	VF	VF	VFR*
	B6	B8	V6	VFR		VFR*
P	B3	B7	V5			VF
	B6	B8	V6			VFR*
F	B3	B7	V5			VF
	B6	B8	V6			VFR*
U	B3	B7	V5			VF
	B6	B8	V6			VFR*

Grundeinbaulage.

Die Getriebe sind ausschließlich in der Grundeinbaulage (B3) beschil-dert; sie können aber auch in abge-leiteten Einbaulagen (B6, B7, B8, V5, V6) installiert werden. Nach der Installation ist es nicht möglich, die Einbaulage zu ändern.

* Die in der Tabelle dargestellten Positionen auf der Klemmenleiste sind nicht für VFR 44 gültig. Für die Zuordnung und die Identifizierung der Bauform ist Bezug auf die Seiten 21 und 126-127 zu nehmen.

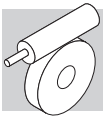

W 63 U ... W 110 U

WR 63 U ... WR 110 U

_HS

_S - _P (IEC)

B3

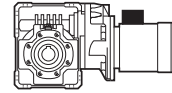
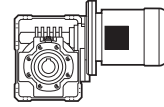
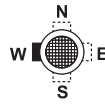
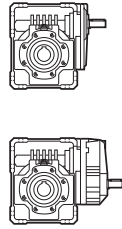
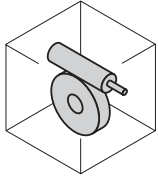

B6

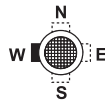
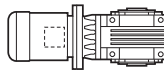
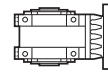
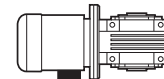
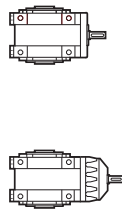
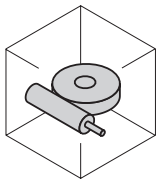

B7

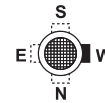
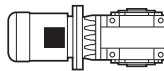
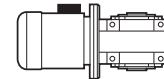
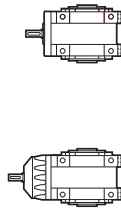
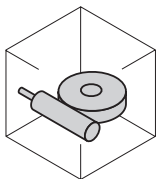

B8

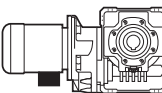
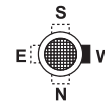
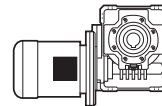
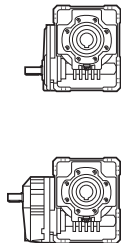
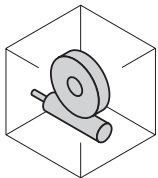

V5

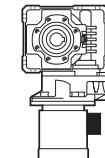
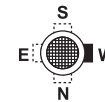
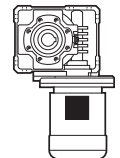
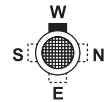
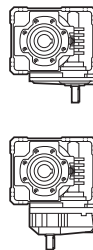
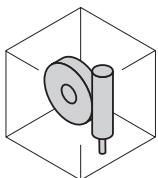

V6

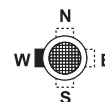
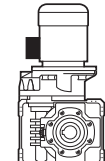
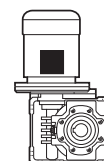
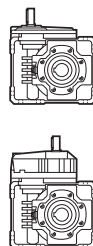
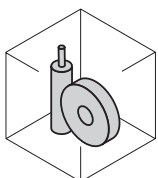

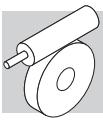

W 63 UF/UFC ... W 110 UF/UFC WR 63 UF/UFC ... WR 110 UF/UFC

_HS

_S - _P (IEC)

B3

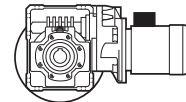
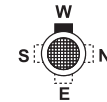
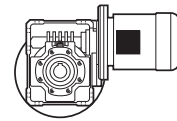
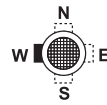
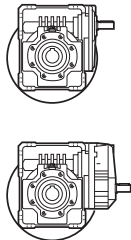
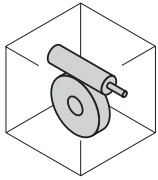

B6

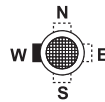
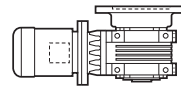
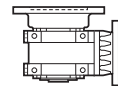
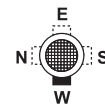
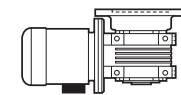
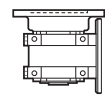
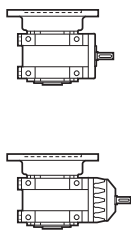
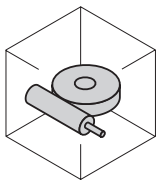

B7

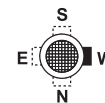
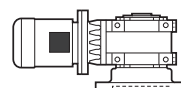
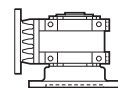
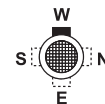
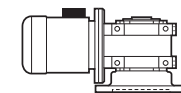
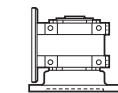
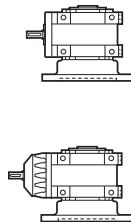
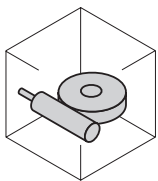

B8

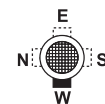
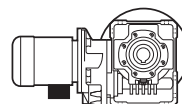
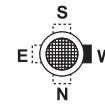
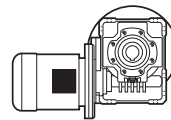
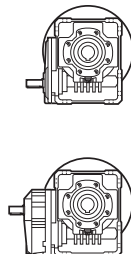
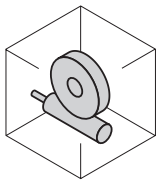

V5

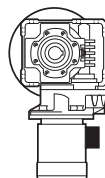
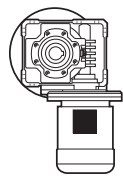
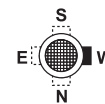
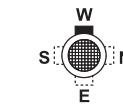
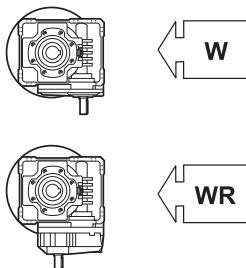
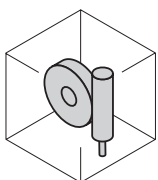

V6

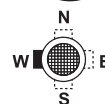
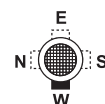
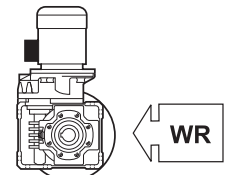
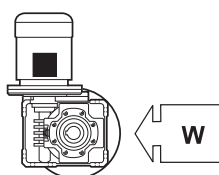
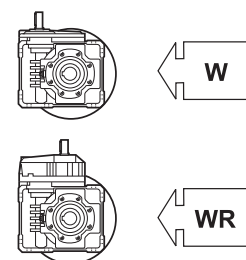
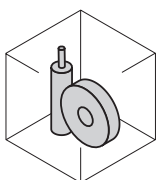

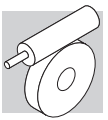

VF 130 A ... VF 250 A VFR 130 A ... VFR 250 A

	_HS	_P (IEC)	
B3			
B6			
B7			
B8			
V5			
V6			

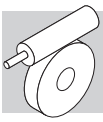

VF 130 N ... VF 250 N

VFR 130 N ... VFR 250 N

_HS

_P (IEC)

B3

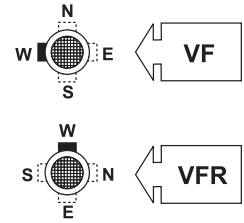
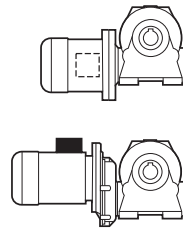
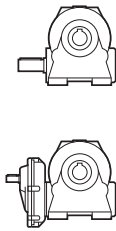
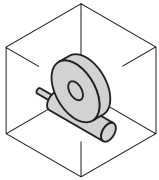

B6

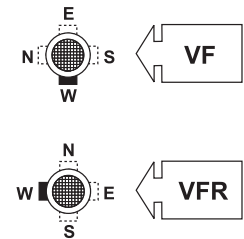
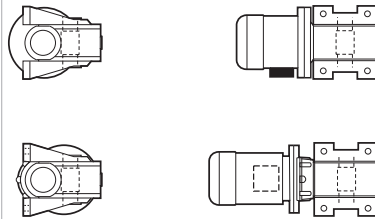
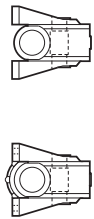
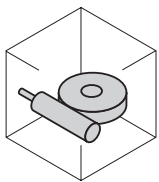

B7

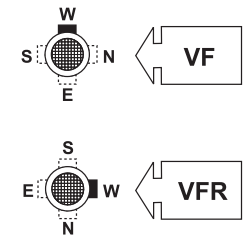
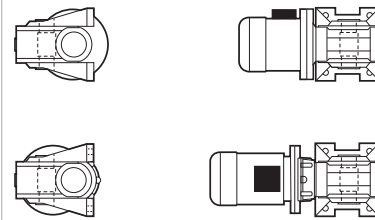
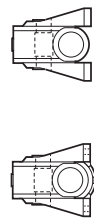
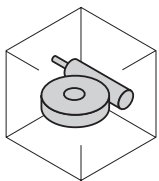

B8

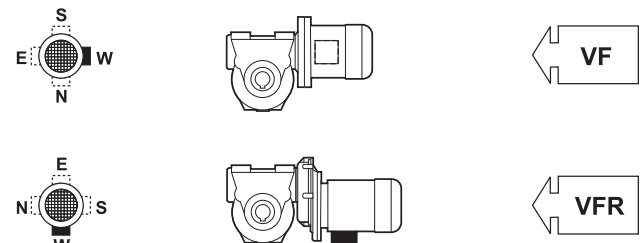
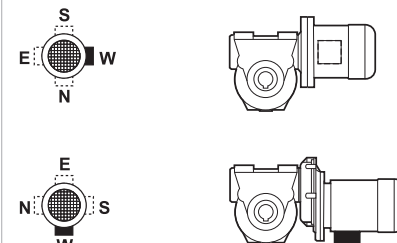
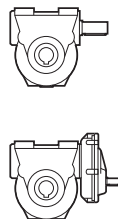
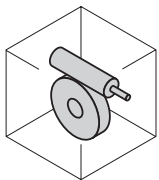

V5

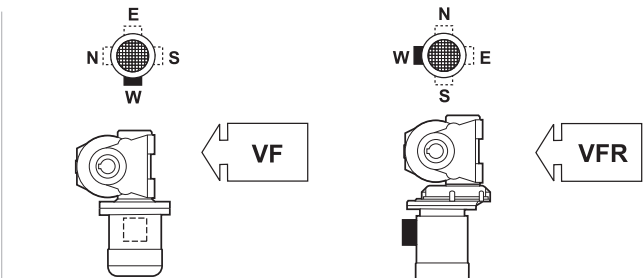
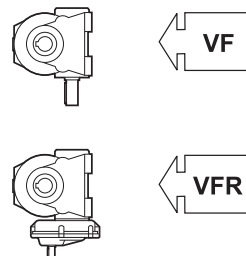
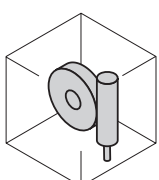



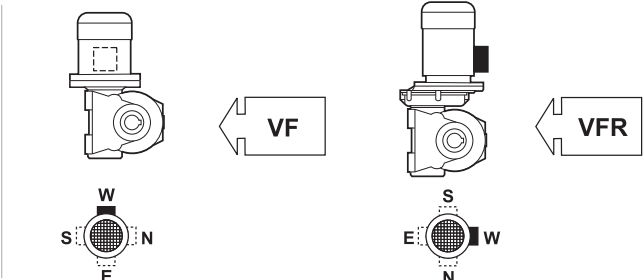
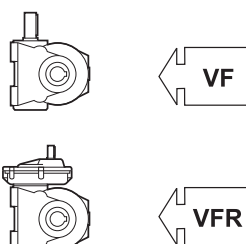
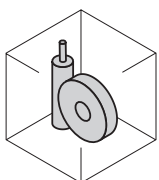





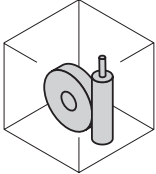
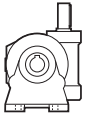

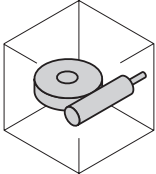

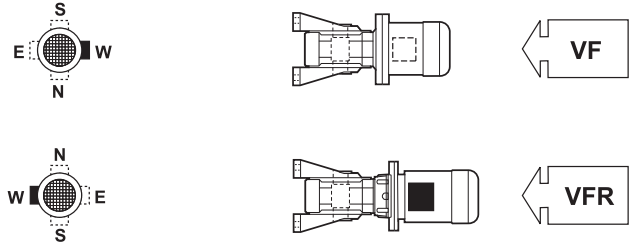
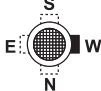
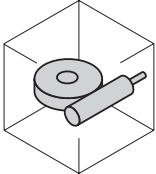
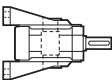
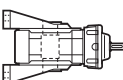
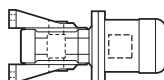
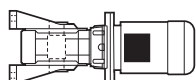
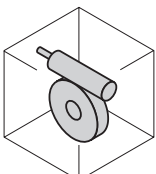
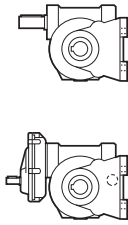
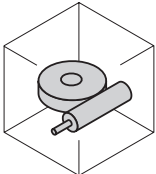
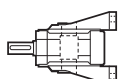
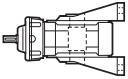
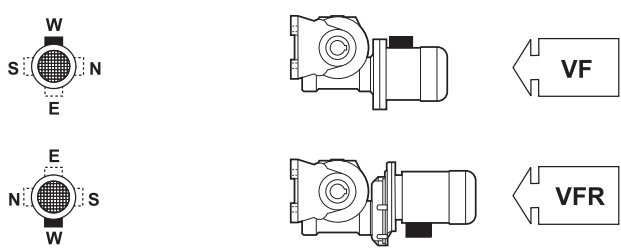
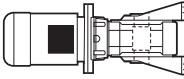

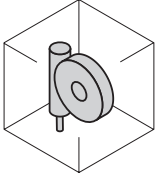



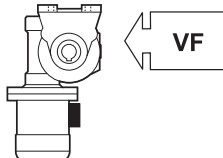

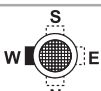
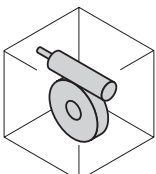
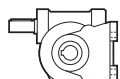

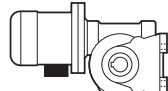
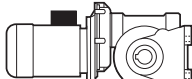
V6

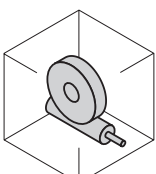



VF 130 V ... VF 250 V VFR 130 V ... VFR 250 V

	_HS	_P (IEC)
B3	  ← VF  ← VFR	 ← VF  ← VFR  N, S, E, W  S, N, E, W
B6	  	 ← VF  ← VFR  S, N, E, W  N, S, E, W
B7	  	 ← VF  ← VFR  N, S, E, W  S, N, E, W
B8	  ← VF  ← VFR	 ← VF  ← VF  S, N, E, W  W, N, E, S
V5	  	 ← VF  ← VFR  E, S, N, W  W, S, N, E
V6	  	 ← VF  ← VF  E, S, N, W  N, S, E, W



VF 130 P ... VF 250 P

VFR 130 P ... VFR 250 P

_HS

_P (IEC)

B3

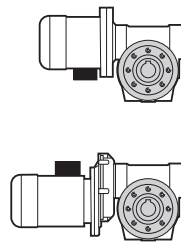
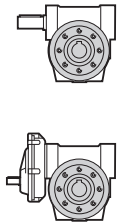
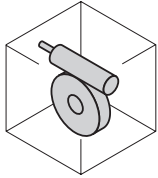

B6

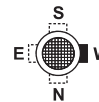
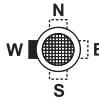
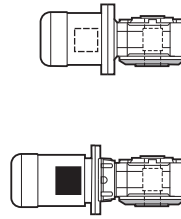
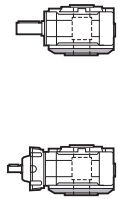
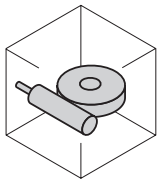

B7

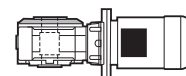
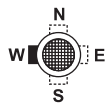
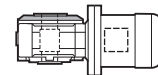
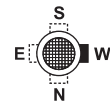
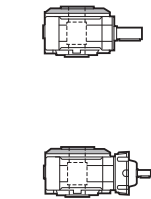
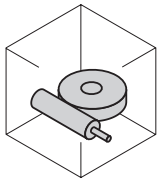

B8

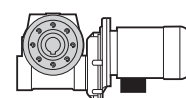
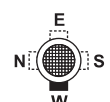
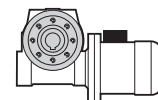
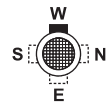
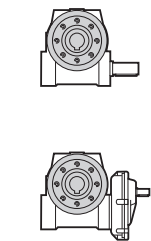
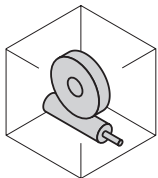

V5

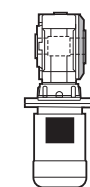
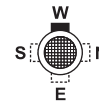
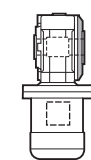
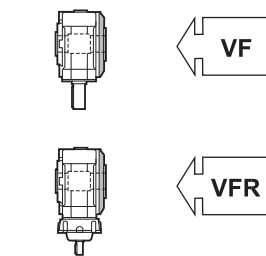
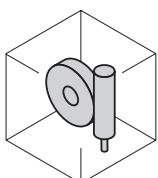

V6

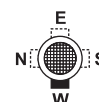
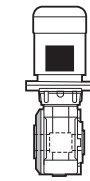
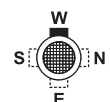
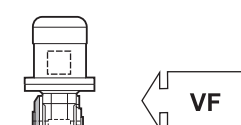
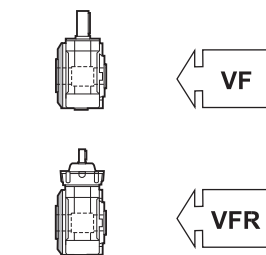
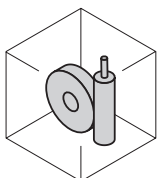



VF 130 F ... VF 250 F VFR 130 F ... VFR 250 F

_HS

_P (IEC)

B3

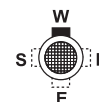
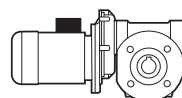
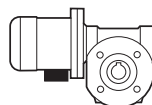
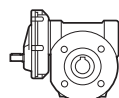
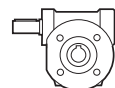
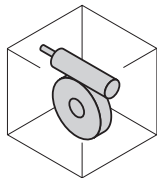

B6

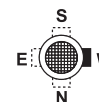
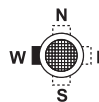
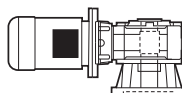
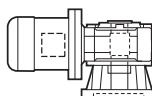
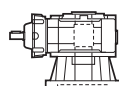
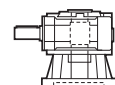
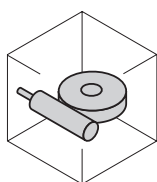

B7

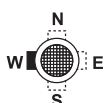
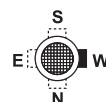
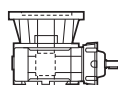
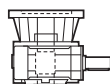
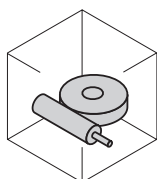

B8

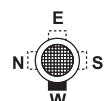
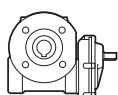
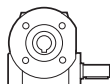
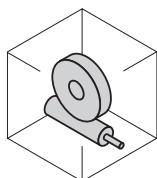

V5

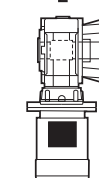
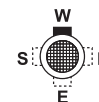
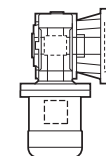
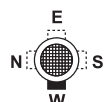
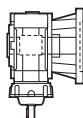
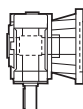
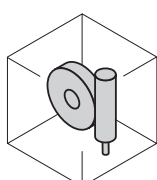

V6

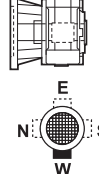
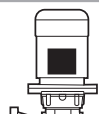
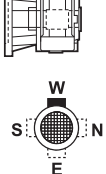
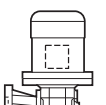
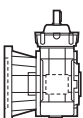
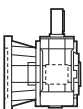
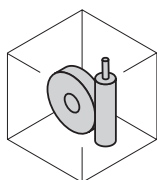



16 RADIALKRÄFTE

16.1 Berechnung der Überhängenden Last

Die mit den Antriebs- und/oder Abtriebswellen des Getriebes verbundenen Antriebsorgane bilden Kräfte, die in radiale Richtung auf die Welle selbst wirken.

Das Ausmaß dieser Kräfte muß mit der Festigkeit des Systems aus Getriebewelle/-lager kompatibel sein, insbesondere muß der absolute Wert der angetragenen Belastung (R_{c1} für Antriebswelle und R_{c2} für Abtriebswelle) unter dem in den Tabellen der Technischen Daten angegebenen Nennwert (R_{n1} für Antriebswelle und R_{n2} für Abtriebswelle) liegen.

In den nachstehenden Formeln bezieht sich die Angabe (1) auf die Maße der Antriebswelle, die Angabe (2) auf die Abtriebswelle.

Die von einem externen Antrieb erzeugte Kraft kann, recht genau, anhand der nachstehenden Formel berechnet werden:

$$R_c = \frac{2000 \times M \times K_r}{d}$$

$K_r = 1$		M [Nm]	
$K_r = 1.25$		d [mm]	
$K_r = 1.5 - 2.0$			

16.2 Überprüfung der Radiallast

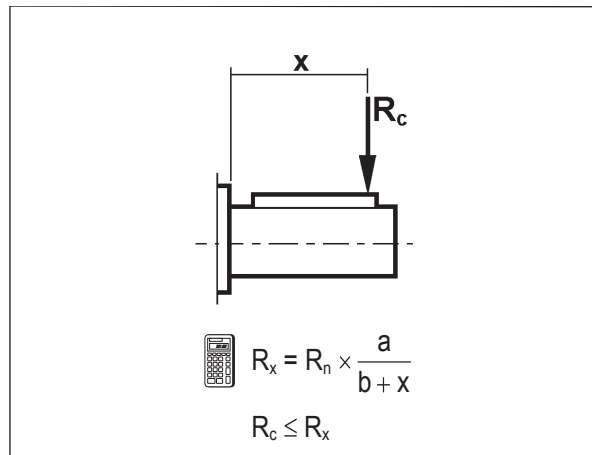
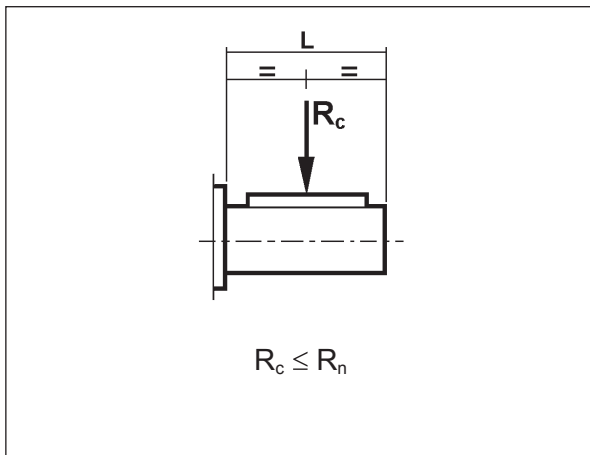



16.3 Getriebekonstanten

	Abtriebswelle		$R_{n2} \text{ max}$ [N]
	a	b	
VF 27	56	44	600
VF 30	60	45	1700
VF 44 - VFR 44 - VF/VF 30/44	71	51	2500
VF 49 - VFR 49 - VF/VF 30/49	99	69	3450
W 63 - WR 63 - VF/W 30/63	132	102	5000
W 75 - WR 75 - VF/W 44/75	139	109	6200
W 86 - WR 86 - VF/W 44/86	149	119	7000
W 110 - WR 110 - VF/W 49/110	173	136	8000
VF 130 - VFR 130 - W/VF 63/130	182	142	13800
VF 150 - VFR 150 - W/VF 86/150	198	155	16000
VF 185 - VFR 185 - W/VF 86/185	220	170	19500
VF 210 - VFR 210 - W/VF 130/210	268	203	34500
VF 250 - VFR 250 - W/VF 130/250	334	252	52000

17 AXIALKRÄFTE

Die Werte der zulässigen, auf die Antriebswelle [A_{n1}] und auf die Abtriebswelle [A_{n2}] einwirkenden Axialkräfte können unter Bezugnahme auf den jeweiligen Wert der Radialkraft [R_{n1}] und [R_{n2}] anhand der nachstehenden Angaben berechnet werden:

$$\begin{aligned} A_{n1} &= R_{n1} \times 0,2 \\ A_{n2} &= R_{n2} \times 0,2 \end{aligned} \quad (14)$$

Die so errechneten Werte der zulässigen Axialkräfte beziehen sich auf den Fall, in dem die Axialkräfte gleichzeitig mit den Nennradialkräften einwirken.

Nur im Fall, es keine Radialbelastung auf die Getriebewelle gibt, ist der Wert der zulässigen Axialbelastung [A_n] gleich zu 50% der zulässigen Radialbelastung [R_n] auf die gleiche Welle. In Anwesenheit von übermäßigen Axialkräften, oder stark auf die Radialkräfte einwirkende Kräfte, wird im Hinblick auf eine genaue Kontrolle empfohlen, sich mit dem Technischen Kundendienst der Bonfiglioli Riduttori in Verbindung zu setzen.



17.1 Maximal zulässige Radialkräfte bei der Bauform FR

Um den Verwendungen entsprechen zu können, die sehr hohe Axialkräfte erfordern, wurde die Bauform FR in den Größen VF 130, VF 150 und VF 185 entwickelt. Diese Bauform, deren äußeren Maße denen der Bauform FC identisch sind, kann die in der nachstehenden Tabelle aufgeführten (weit über den von den Standardformen zugelassenen liegenden) und sich auf das Übersetzungsverhältnis [i] und die Drehrichtung +/- der Abtriebswelle bezogenen Axialkräfte aufnehmen.

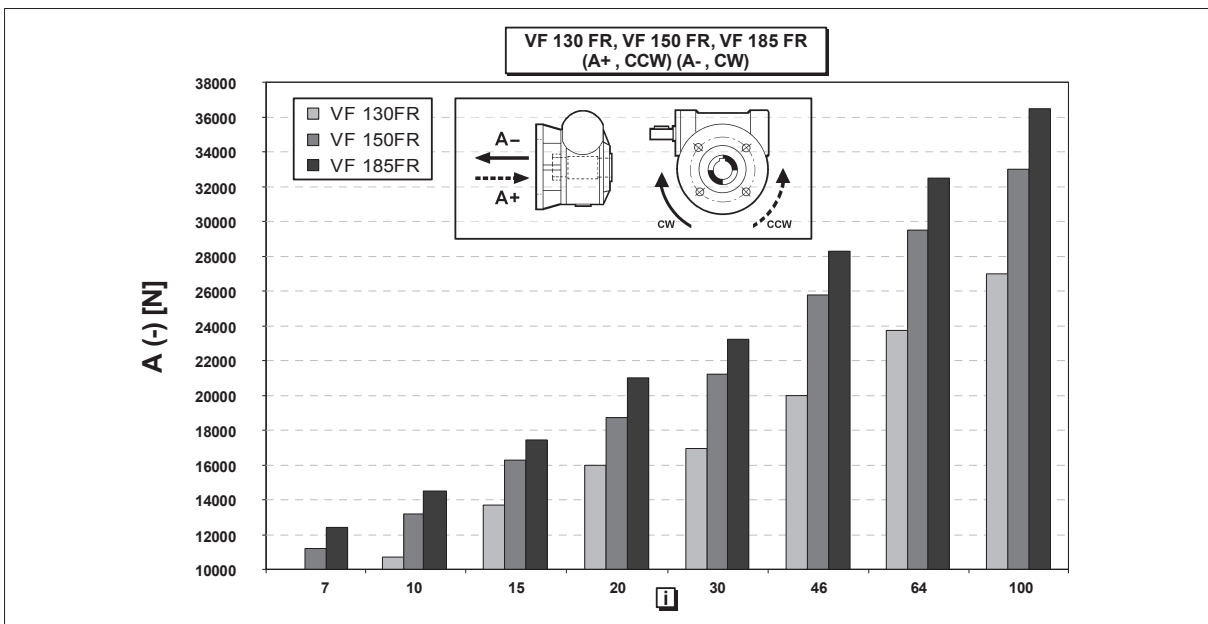
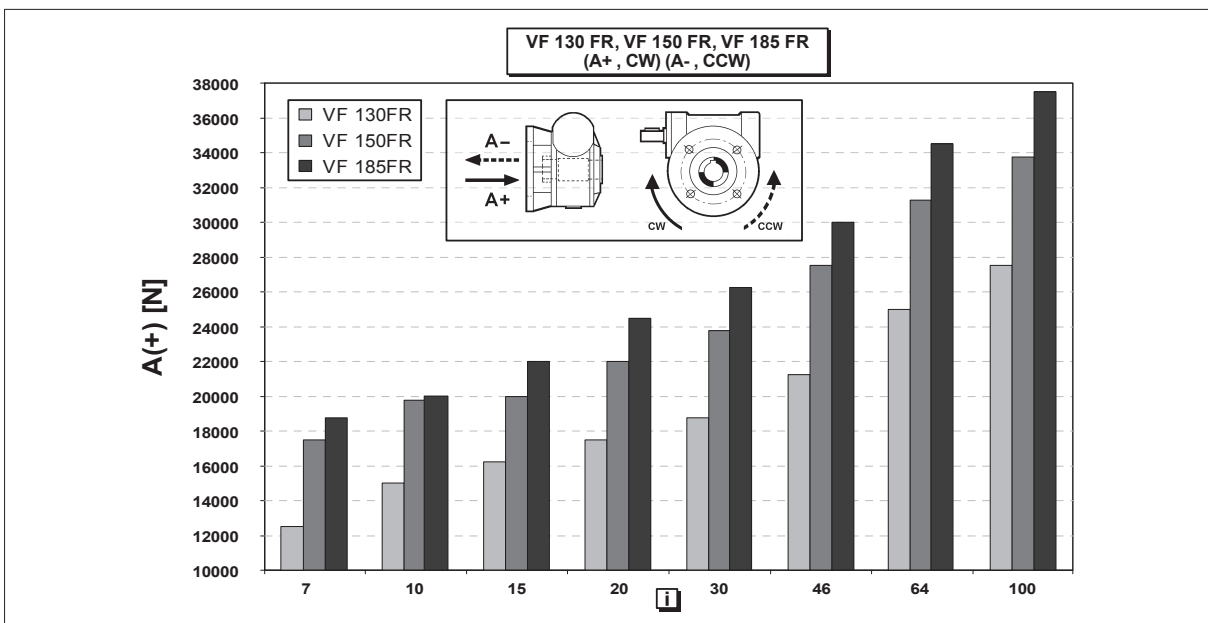
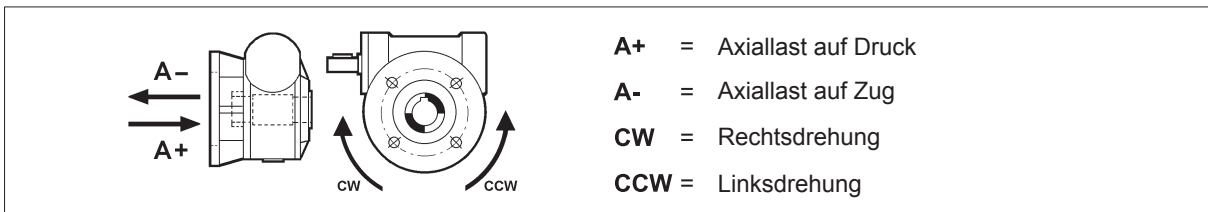

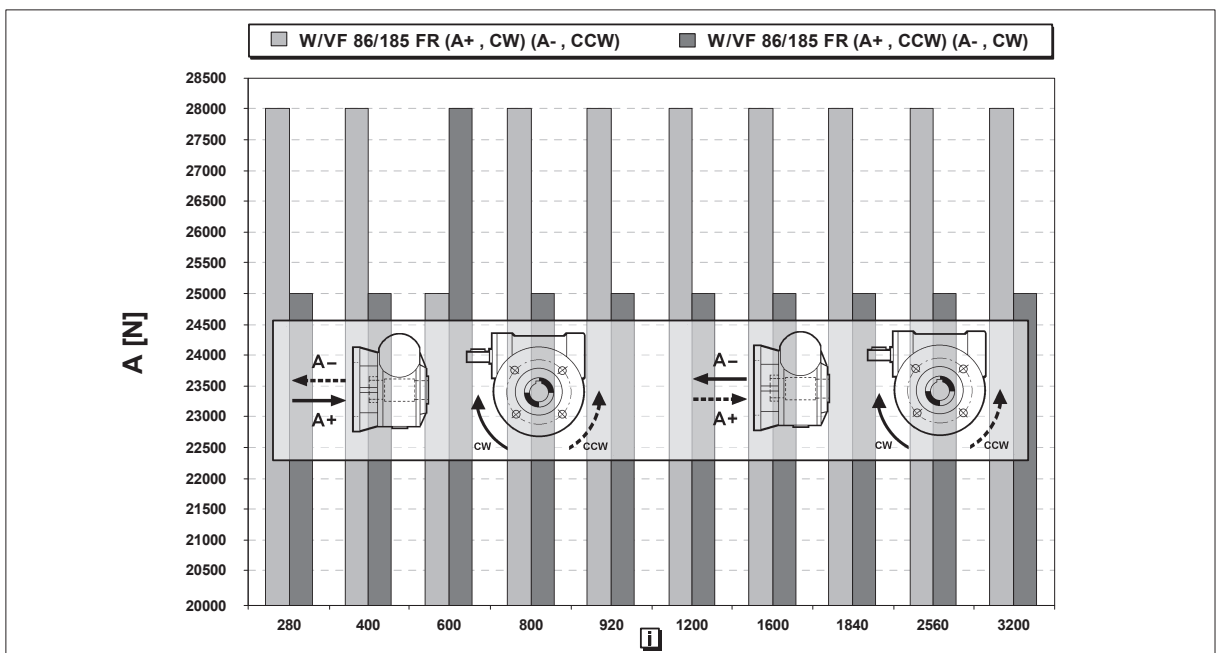
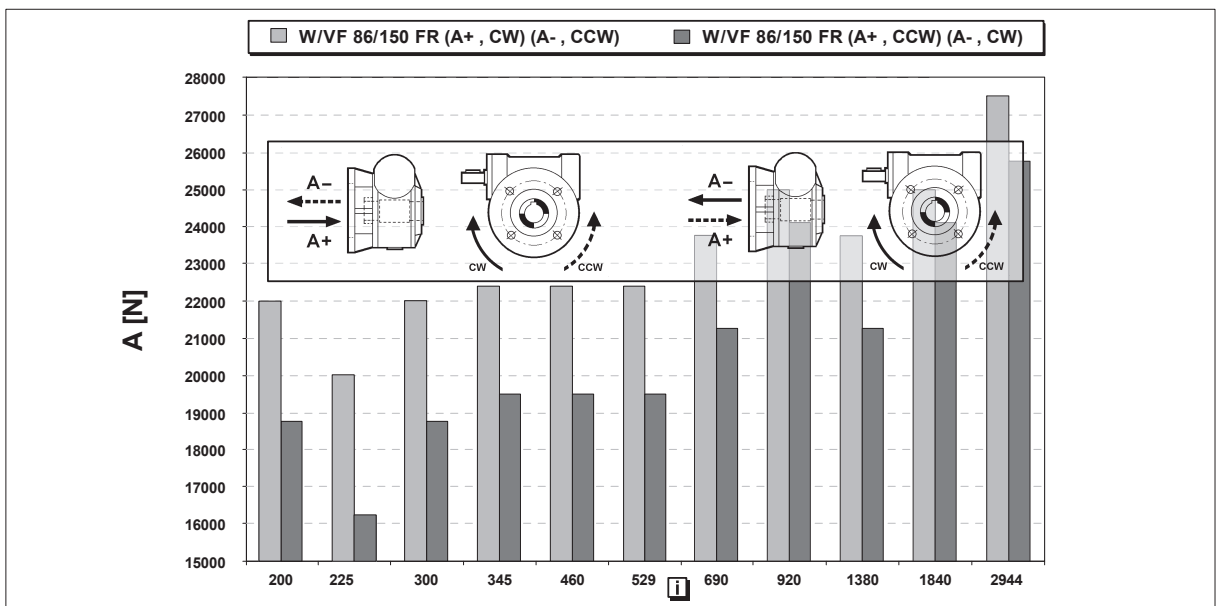
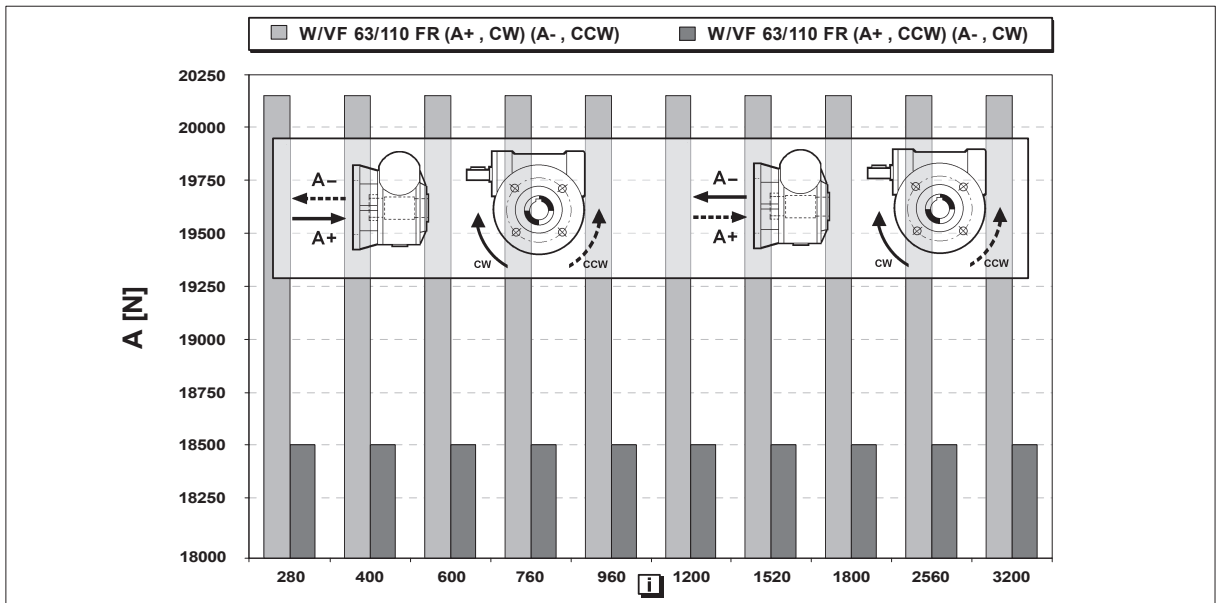



18 WIRKUNGSGRAD

Der Wirkungsgrad $[\eta]$ hängt von den folgenden Parametern ab:

- Eingriffswinkel
- Schmierung
- Einlaufen des Getriebes

Dabei ist auch zu berücksichtigen, daß der beste Wert erst nach einer Einlaufphase von einigen Stunden erreicht wird, aus Abbildung unter geht hervor, vann bei Getrieben, die mit Nenn Drehzahlen arbeiten der beste Wirkungsgrad erreicht wird. Für Anwendungsfälle mit intermittierendem Betrieb (Heben, Antrieb, sw.) ist es notwendig, die Motorleistung angemessen zu erhöhen, um den ungünstigen Wirkungsgrad des Getriebes während des Anfahrens zu überwinden.

Die Drehmomentwerte M_{n2} , die im Katalog angegeben sind, wurden im Hinblick auf den Wirkungsgrad von Getrieben berechnet, die bei einer Drehzahl von h_d laufen.

Die Abbildung zeigt die Zeit, die ungefähr notwendig ist, um den maximalen dynamischen Wirkungsgrad zu erreichen.

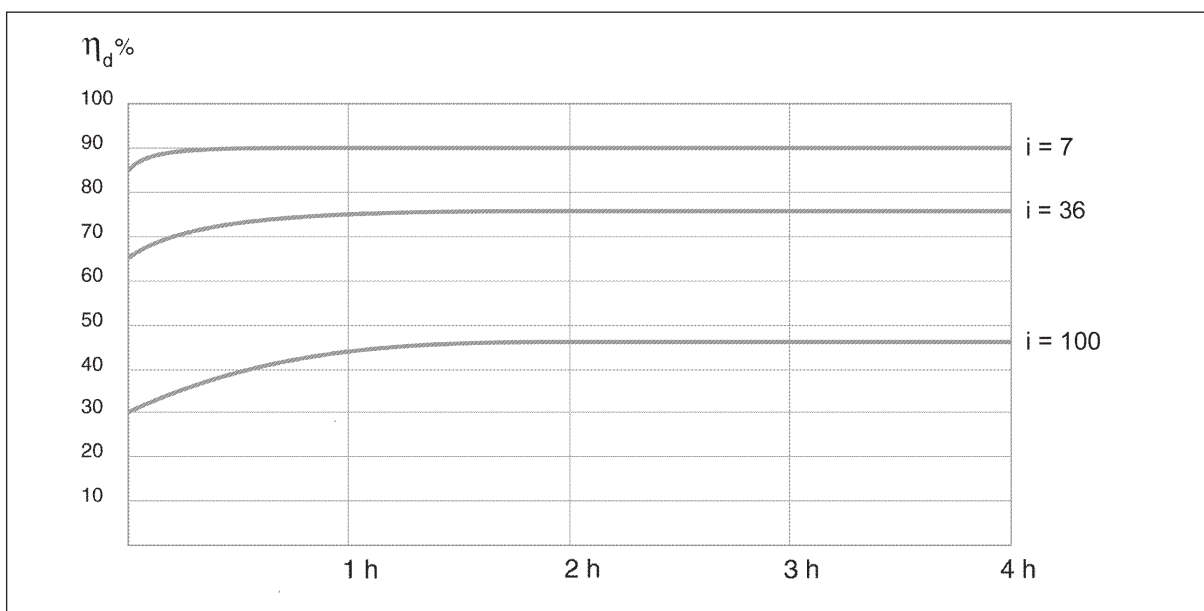

19 SELBSTHEMMUNG

Einige Applikationsarten können gelegentlich dazu führen, dass die Antriebübertragung über die Abtriebswelle erfolgt, während andere es erforderlich machen, dass die Last, auch ohne elektrische Versorgung, vom Getriebemotor in Position gehalten wird. Einige Schneckeneinheiten bieten die Eigenschaft der Nichtumkehrbarkeit und der Kennwert, der diese Eigenschaft am meisten beeinflusst, stellt sich in ihrem Wirkungsgrad dar. Insbesondere ist der statische Wirkungsgrad η_s für die statische Nichtumkehrbarkeit (Passage über eine Aussetzposition) verantwortlich, während der dynamische Wirkungsgrad η_d für die eventuelle dynamische Nichtumkehrbarkeit (kontinuierlicher Antrieb in die gleiche Richtung) zuständig ist. Die Nichtumkehrbarkeit kann sich bei längeren Übersetzungsverhältnissen ($i=64$ und höher) in anderen Maßen ausdrücken und so eine immer höhere Nichtumkehrbarkeit bieten.

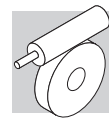

19.1 Statische Selbsthemmung

Unter dieser Bedingung ist bei Belastung der Abtriebswelle im Stillstand kein Durchlaufen möglich, jedoch sind kleine Bewegungen im Falle von Vibrationen nicht auszuschließen. Die theoretische Voraussetzung für eine statische Selbsthemmung ist:

$$\eta_s < 0.4 - 0.5 \quad (15)$$

wobei der statische Wirkungsgrad η_s ist (diesen Wert findet man in den Tabellen der technischen Daten der Getriebe). Das genaue Gegenteil, ein Weiterdrehen der Antriebswelle aus dem Stillstand, ergibt sich bei:

$$\eta_s > 0.5 \quad (16)$$

19.2 Dynamische Selbsthemmung

Diese Eigenschaft ist äußerst schwierig zu erreichen, da sie direkt von der Drehzahl, dem Wirkungsgrad und andauernden Vibrationen der Last abhängig ist.

Sie wird durch einen praktisch sofortigen Stillstand charakterisiert, wenn die Schneckenwelle nicht mehr angetrieben wird.

$$\eta_d < 0.5 \quad (17)$$

Die theoretische Voraussetzung für eine dynamische Selbsthemmung ist ein dynamischer Wirkungsgrad von bei reellen Betriebsbedingungen (den Wert findet man in den Tabellen der technischen Daten der Getriebe), während das Gegenteil bei einem Wirkungsgrad von:

$$\eta_d > 0.5 \quad (18)$$

Die Abbildung unter gibt Auskunft über die verschiedenen Reversierbarkeitsstufen, je nach Getriebeart und dem Untersetzungsverhältnis (die Angaben beziehen sich nur auf das Kräftepaar Schneckenwelle-Schneckenrad).

Natürlich dienen diese Daten nur zur allgemeinen Information, denn die Selbsthemmung kann wegen den bereits genannten Faktoren mehr oder weniger verstärkt sein.



Da es praktisch unmöglich ist, eine totale Selbsthemmung zu realisieren oder zu garantieren, muß man, falls diese unerlässlich sein sollte, eine äußere Bremse anbringen, die ein durch Vibrationen verursachtes Anlaufen ausschließt.



		Selbsthemmungsgrad												
		VF				W				VF				
Statische Reversierbarkeit	Dynamische Reversierbarkeit	27	30	44	49	63	75	86	110	130	150	185	210	250
ja	ja	—	—	7	7	7	7	7	7	7	7	7	7	7
ja	ja	7 10	7 10	10 14	10 14	10 12 15	10 15	10 15 20 23	10 15 20 23	10 15 20 23	10 15 20 23	10 15 20 23	10 15 20 23	
unsicher	ja	15 20 30	15 20 30	20 28 35	18 24 28 36	19 24 30 38	20 25 30 40	30 40 46 56	30 40 46 56	30 40 46 56 64	30 40 46 56 64	30 40 50 60	30 40 50 60	
no	leicht	40 60	40 60	46 60 70	45 60 70	45 64 80	50 60 80	64 80 100	64 80 100	80 100	80 100	80 100	60 80 100	80 100
no	no	70	70	100	80 100	100	100	—	—	—	—	—	—	—

20 WINKELSPIELE

In der nachstehenden Tabelle werden die Anhaltswerte für das Winkelspiel bezüglich der Abtriebswelle, d.h. also bei blockierter Antriebswelle, gegeben. Das Maß ist durch das Ansetzen eines Drehmoments von 5 Nm an der Abtriebswelle erhältlich

Winkelspiele (Antriebswelle blockiert)		
	$\Delta\gamma$ [']	$\Delta\gamma$ [rad]
VF 30	33' ± 10'	0.00873 ± 0.00291
VF 44	25' ± 7'	0.00728 ± 0.00145
VFR 44	30' ± 10'	0.00873 ± 0.00291
VF 49	22' ± 7'	0.00728 ± 0.00145
VFR 49	30' ± 10'	0.00873 ± 0.00291
W 63	20' ± 4'	0.00582 ± 0.00145
WR 63	25' ± 5'	0.00728 ± 0.00145
W 75	18' ± 4'	0.00582 ± 0.00145
WR 75	22' ± 5'	0.00640 ± 0.00145
W 86	15' ± 4'	0.00436 ± 0.00145
WR 86	20' ± 5'	0.00582 ± 0.00145
W 110	9' ± 2'	0.00436 ± 0.00145
WR 110	18' ± 5'	0.00524 ± 0.00145
VF 130	12' ± 3'	0.00349 ± 0.00087
VFR 130	15' ± 3'	0.00436 ± 0.00087
VF 150	12' ± 3'	0.00349 ± 0.00087
VFR 150	15' ± 3'	0.00436 ± 0.00087
VF 185	10' ± 3'	0.00291 ± 0.00087
VFR 185	13' ± 3'	0.00378 ± 0.00087
VF 210	Rückfrage an Hersteller	
VFR 210		
VF 250		
VFR 250		







21 GETRIEBEMOTOREN-AUSWAHLTABELLEN







Die Auswahl der Motoren ohne Bremse erfolgt nach den Vorgaben der Verordnung EG 640/2009 (siehe abschnitt **M** dieses Katalogs). Für Nennleistungen unter 0,75 kW können die BN/M-Motoren vorgesehen werden.

Die Verordnung EG 640/2009 gilt nicht für die Bremsmotoren, d.h., bei der Auswahl der Bremsmotoren sind die BN/M-Motoren in Betracht zu ziehen, ohne den Wert der Nennleistung zu berücksichtigen. Die BX, BE, MX und ME-Bremsmotoren sind auf Anfrage verfügbar.

0.04 kW

n_2 min ⁻¹	M_2 Nm	S	i	R_{n2} N	 IE1		 IEC 			
19.3	9	1.0	70	600			VF 27_70	P27	BN27A4	121
22.5	8	1.1	60	600			VF 27_60	P27	BN27A4	121
34	6	1.4	40	600			VF 27_40	P27	BN27A4	121
45	5	1.7	30	600			VF 27_30	P27	BN27A4	121
68	4	2.2	20	600			VF 27_20	P27	BN27A4	121
90	3	2.8	15	600			VF 27_15	P27	BN27A4	121
135	2	3.8	10	600			VF 27_10	P27	BN27A4	121
193	2	5.5	7	600			VF 27_7	P27	BN27A4	121

0.06 kW

n_2 min ⁻¹	M_2 Nm	S	i	R_{n2} N	 IE1		 IEC 			
0.59	203	1.0	2280	5000			VF/W 30/63_2280	P56	BN56A4	139
0.89	155	1.4	1520	5000			VF/W 30/63_1520	P56	BN56A4	139
1.1	122	1.7	1200	5000			VF/W 30/63_1200	P56	BN56A4	139
1.5	115	1.8	900	5000			VF/W 30/63_900	P56	BN56A4	139
1.9	113	1.9	720	5000			VF/W 30/63_720	P56	BN56A4	139
2.5	85	1.1	540	3450			VF/VF 30/49_540	P56	BN56A4	134
2.8	50	1.0	500	5000			VFR 44_500	S44	BN44B4	126
3.2	73	1.3	420	3450			VF/VF 30/49_420	P56	BN56A4	134
4.0	54	1.0	350	5000			VFR 44_350	S44	BN44B4	126
4.3	53	1.8	315	3450			VF/VF 30/49_315	P56	BN56A4	134
4.5	59	1.0	300	2500			VFR 44_300	S44	BN44B4	126
5.8	50	1.2	230	2500			VFR 44_230	S44	BN44B4	126
7.7	42	1.5	175	2500			VFR 44_175	S44	BN44B4	126
9.6	36	1.4	140	2500			VFR 44_140	S44	BN44B4	126
13.4	29	1.8	100	2500			VFR 44_100	S44	BN44B4	126
19.1	22	1.8	70	2500			VFR 44_70	S44	BN44B4	126
19.3	14	1.1	70	1600			VF 30_70	P56	BN56A4	122
22.5	13	1.5	60	1600			VF 30_60	P56	BN56A4	122
34	10	0.9	40	600			VF 27_40	P27	BN27B4	121
34	10	1.9	40	1650			VF 30_40	P56	BN56A4	122
45	8	1.1	30	600			VF 27_30	P27	BN27B4	121
45	8	2.4	30	1340			VF 30_30	P56	BN56A4	122
68	6	1.5	20	600			VF 27_20	P27	BN27B4	121
68	6	2.9	20	1180			VF 30_20	P56	BN56A4	122



0.06 kW



n ₂ min ⁻¹	M ₂ Nm	S	i	R _{n2} N	IE1		IEC		IE1	
90	5	1.9	15	600			VF 27_15	P27	BN27B4	121
90	5	3.7	15	1080			VF 30_15	P56	BN56A4	122
135	4	2.6	10	590			VF 27_10	P27	BN27B4	121
135	3	4.7	10	950			VF 30_10	P56	BN56A4	122
193	2	3.6	7	530			VF 27_7	P27	BN27B4	121
193	2	6.4	7	840			VF 30_7	P56	BN56A4	122

0.09 kW



n ₂ min ⁻¹	M ₂ Nm	S	i	R _{n2} N	IE1		IEC		IE1	
0.31	574	1.8	2800	8000			VF/W 49/110_2800	P63	BN63A6	151
0.42	579	1.0	2116	7000			VF/W 44/86_2116	P63	BN63A6	147
0.43	505	2.1	2070	8000			VF/W 49/110_2070	P63	BN63A6	151
0.48	503	1.1	1840	7000			VF/W 44/86_1840	P63	BN63A6	147
0.53	485	2.2	1656	8000			VF/W 49/110_1656	P63	BN63A6	151
0.64	377	1.5	1380	7000			VF/W 44/86_1380	P63	BN63A6	147
0.65	369	2.8	1350	8000			VF/W 49/110_1350	P63	BN63A6	151
0.73	363	1.1	1200	5750			VF/W 44/75_1200	P63	BN63A6	143
0.81	316	3.3	1080	8000			VF/W 49/110_1080	P63	BN63A6	151
0.89	232	0.9	1520	5000			VF/W 30/63_1520	P56	BN56B4	139
0.96	323	1.2	920	5750			VF/W 44/75_920	P63	BN63A6	143
0.96	332	1.7	920	7000			VF/W 44/86_920	P63	BN63A6	147
0.98	255	0.9	900	5000			VF/W 30/63_900	P63	BN63A6	139
1.1	183	1.1	1200	5000			VF/W 30/63_1200	P56	BN56B4	139
1.2	225	1.0	720	5000			VF/W 30/63_720	P63	BN63A6	139
1.3	267	1.5	700	5750			VF/W 44/75_700	P63	BN63A6	143
1.3	253	2.2	700	7000			VF/W 44/86_700	P63	BN63A6	147
1.5	172	1.2	900	5000			VF/W 30/63_900	P56	BN56B4	139
1.7	210	1.9	525	5750			VF/W 44/75_525	P63	BN63A6	143
1.7	200	2.8	525	7000			VF/W 44/86_525	P63	BN63A6	147
1.9	170	1.2	720	5000			VF/W 30/63_720	P56	BN56B4	139
2.2	164	2.4	400	5750			VF/W 44/75_400	P63	BN63A6	143
2.2	160	3.4	400	7000			VF/W 44/86_400	P63	BN63A6	147
2.4	145	1.4	570	5000			VF/W 30/63_570	P56	BN56B4	139
2.9	111	1.2	300	5000			WR 63_300	P63	BN63A6	138
2.9	120	1.7	300	6200			WR 75_300	P63	BN63A6	142
2.9	132	2.4	300	7000			WR 86_300	P63	BN63A6	146
3.0	117	1.8	450	5000			VF/W 30/63_450	P56	BN56B4	139
3.2	110	0.9	420	3450			VF/VF 30/49_420	P56	BN56B4	134
3.7	101	1.4	240	5000			WR 63_240	P63	BN63A6	138
3.7	105	2.1	240	6200			WR 75_240	P63	BN63A6	142
3.7	117	2.6	240	7000			WR 86_240	P63	BN63A6	146
4.2	84	0.9	210	3450			VFR 49_210	P63	BN63A6	132
4.3	80	1.2	315	3450			VF/VF 30/49_315	P56	BN56B4	134
4.3	84	2.5	315	5000			VF/W 30/63_315	P56	BN56B4	139
4.6	88	1.7	192	5000			WR 63_192	P63	BN63A6	138
4.9	79	0.9	180	3450			VFR 49_180	P63	BN63A6	132
4.9	90	3.1	180	6200			WR 75_180	P63	BN63A6	142
5.2	94	4.2	168	7000			WR 86_168	P63	BN63A6	146
5.5	62	1.0	245	2500			VF/VF 30/44_245	P56	BN56B4	128
6.5	66	1.2	135	3450			VFR 49_135	P63	BN63A6	132
6.5	71	2.5	135	5000			WR 63_135	P63	BN63A6	138
7.7	63	1.0	175	2900			VFR 44_175	S44	BN44C4	126
7.7	65	3.1	114	5000			WR 63_114	P63	BN63A6	138
8.1	58	1.4	108	3450			VFR 49_108	P63	BN63A6	132
8.8	41	1.3	100	3300			VF 49_100	P63	BN63A6	130
9.6	54	0.9	140	2900			VFR 44_140	S44	BN44C4	126
9.8	55	3.8	90	5000			WR 63_90	P63	BN63A6	138
10.5	48	1.9	84	3450			VFR 49_84	P63	BN63A6	132
11.0	37	1.6	80	3300			VF 49_80	P63	BN63A6	130
12.2	45	1.8	72	3450			VFR 49_72	P63	BN63A6	132
12.2	48	4.0	72	5000			WR 63_72	P63	BN63A6	138
12.6	35	1.1	70	2300			VF 44_70	P63	BN63A6	124
12.6	34	1.8	70	3300			VF 49_70	P63	BN63A6	130
13.4	43	1.2	100	2900			VFR 44_100	S44	BN44C4	126
14.7	32	1.4	60	2300			VF 44_60	P63	BN63A6	124
14.7	34	1.7	60	3300			VF 49_60	P63	BN63A6	130
16.3	36	2.2	54	3450			VFR 49_54	P63	BN63A6	132
19.1	33	1.2	70	2900			VFR 44_70	S44	BN44C4	126
19.1	27	1.8	46	2300			VF 44_46	P63	BN63A6	124

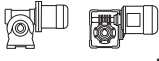

0.09 kW





n ₂ min ⁻¹	M ₂ Nm	S	i	R _{n2} N	 IE1		 IE1			
19.6	26	2.7	45	3300			VF 49_45	P63	BN63A6	130
21.0	30	2.8	42	3360			VFR 49_42	P63	BN63A6	132
22.0	22	0.9	40	1560			VF 30_40	P63	BN63A6	122
22.5	19	1.0	60	1600			VF 30_60	P56	BN56B4	122
24.4	22	3.4	36	3300			VF 49_36	P63	BN63A6	130
25.1	22	2.2	35	2300			VF 44_35	P63	BN63A6	124
29.3	18	1.2	30	1440			VF 30_30	P63	BN63A6	122
31	18	2.7	28	2300			VF 44_28	P63	BN63A6	124
34	15	1.2	40	1410			VF 30_40	P56	BN56B4	122
44	14	1.5	20	1230			VF 30_20	P63	BN63A6	122
44	14	3.1	20	2300			VF 44_20	P63	BN63A6	124
45	12	1.6	30	1290			VF 30_30	P56	BN56B4	122
59	11	1.8	15	1170			VF 30_15	P63	BN63A6	122
68	9	1.9	20	1140			VF 30_20	P56	BN56B4	122
69	9	1.0	20	600			VF 27_20	P27	BN27C4	121
88	8	2.3	10	1050			VF 30_10	P63	BN63A6	122
90	7	2.5	15	1050			VF 30_15	P56	BN56B4	122
92	7	1.3	15	600			VF 27_15	P27	BN27C4	121
126	6	3.2	7	920			VF 30_7	P63	BN63A6	122
135	5	3.1	10	920			VF 30_10	P56	BN56B4	122
138	5	1.7	10	565			VF 27_10	P27	BN27C4	121
193	4	4.3	7	820			VF 30_7	P56	BN56B4	122
197	4	2.5	7	510			VF 27_7	P27	BN27C4	121

0.12 kW



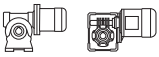

n ₂ min ⁻¹	M ₂ Nm	S	i	R _{n2} N	 IE1 IE2		 IE1 IE2				
0.31	775	1.4	2800	8000			VF/W 49/110_2800	P63	BN63B6	151	
0.47	588	1.7	2800	8000			VF/W 49/110_2800	P63	BN63A4	BE63A4	151
0.53	654	1.6	1656	8000			VF/W 49/110_1656	P63	BN63B6		151
0.62	518	1.0	2116	7000			VF/W 44/86_2116	P63	BN63A4	BE63A4	147
0.63	507	2.0	2070	8000			VF/W 49/110_2070	P63	BN63A4	BE63A4	151
0.71	483	1.0	1840	7000			VF/W 44/86_1840	P63	BN63A4	BE63A4	147
0.79	435	2.3	1656	8000			VF/W 49/110_1656	P63	BN63A4	BE63A4	151
0.95	386	1.3	1380	7000			VF/W 44/86_1380	P63	BN63A4	BE63A4	147
0.97	354	2.8	1350	8000			VF/W 49/110_1350	P63	BN63A4	BE63A4	151
1.2	293	3.4	1080	8000			VF/W 49/110_1080	P63	BN63A4	BE63A4	151
1.4	322	1.1	920	5750			VF/W 44/75_920	P63	BN63A4	BE63A4	143
1.4	322	1.6	920	7000			VF/W 44/86_920	P63	BN63A4	BE63A4	147
1.5	236	0.9	900	5000			VF/W 30/63_900	P63	BN63A4	BE63A4	139
1.8	233	0.9	720	5000			VF/W 30/63_720	P63	BN63A4	BE63A4	139
1.9	257	1.4	700	5750			VF/W 44/75_700	P63	BN63A4	BE63A4	143
1.9	239	2.1	700	7000			VF/W 44/86_700	P63	BN63A4	BE63A4	147
2.3	199	1.1	570	5000			VF/W 30/63_570	P63	BN63A4	BE63A4	139
2.5	202	1.8	525	5750			VF/W 44/75_525	P63	BN63A4	BE63A4	143
2.5	193	2.6	525	7000			VF/W 44/86_525	P63	BN63A4	BE63A4	147
2.9	150	0.9	300	5000			WR 63_300	P63	BN63B6		138
2.9	162	1.2	300	6200			WR 75_300	P63	BN63B6		142
2.9	178	1.7	300	7000			WR 86_300	P63	BN63B6		146
2.9	161	1.3	450	5000			VF/W 30/63_450	P63	BN63A4	BE63A4	139
3.3	161	2.3	400	5750			VF/W 44/75_400	P63	BN63A4	BE63A4	143
3.3	143	3.5	400	7000			VF/W 44/86_400	P63	BN63A4	BE63A4	147
3.6	136	1.0	240	5000			WR 63_240	P63	BN63B6		138
3.6	142	1.5	240	6200			WR 75_240	P63	BN63B6		142
3.6	142	1.6	240	5000			VF/W 30/63_240	P63	BN63B6		139
3.6	158	2.0	240	7000			WR 86_240	P63	BN63B6		146
4.2	110	0.9	315	3450			VF/VF 30/49_315	P63	BN63A4	BE63A4	134
4.2	116	1.8	315	5000			VF/W 30/63_315	P63	BN63A4	BE63A4	139
4.4	108	1.2	300	5000			WR 63_300	P63	BN63A4	BE63A4	138
4.4	115	1.6	300	6200			WR 75_300	P63	BN63A4	BE63A4	142
4.4	129	2.1	300	7000			WR 86_300	P63	BN63A4	BE63A4	146
4.4	134	2.8	300	5750			VF/W 44/75_300	P63	BN63A4	BE63A4	143
4.8	121	2.3	180	6200			WR 75_180	P63	BN63B6		142
5.2	126	3.1	168	7000			WR 86_168	P63	BN63B6		146
5.2	125	3.0	250	5750			VF/W 44/75_250	P63	BN63A4	BE63A4	143
5.5	94	1.0	240	3450			VF/VF 30/49_240	P63	BN63A4	BE63A4	134
5.5	97	1.4	240	5000			WR 63_240	P63	BN63A4	BE63A4	138
5.5	103	2.1	240	6200			WR 75_240	P63	BN63A4	BE63A4	142
5.5	99	2.1	240	5000			VF/W 30/63_240	P63	BN63A4	BE63A4	139
5.5	111	2.7	240	7000			WR 86_240	P63	BN63A4	BE63A4	146
5.8	109	2.9	150	6200			WR 75_150	P63	BN63B6		142

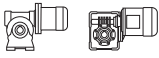

0.12 kW

n ₂ min ⁻¹	M ₂ Nm	S	i	R _{n2} N	 IE1 IE2			 IEC IE1 IE2			
6.4	89	0.9	135	3300			VFR 49_135	P63	BN63B6	132	
6.4	96	1.9	135	5000			WR 63_135	P63	BN63B6	138	
6.8	86	1.8	192	5000			WR 63_192	P63	BN63A4	BE63A4	138
7.3	76	0.9	180	3300			VFR 49_180	P63	BN63A4	BE63A4	132
7.3	87	2.7	180	6200			WR 75_180	P63	BN63A4	BE63A4	142
8.7	55	0.9	100	3300			VF 49_100	P63	BN63B6	130	
9.7	64	1.4	135	3450			VFR 49_135	P63	BN63A4	BE63A4	132
9.7	68	2.5	135	5000			WR 63_135	P63	BN63A4	BE63A4	138
10.9	50	1.2	80	3300			VF 49_80	P63	BN63B6	130	
11.5	61	3.0	114	5000			WR 63_114	P63	BN63A4	BE63A4	138
12.1	55	1.5	108	3450			VFR 49_108	P63	BN63A4	BE63A4	132
13.1	41	1.2	100	3150			VF 49_100	P63	BN63A4	BE63A4	130
14.5	43	1.1	60	2300			VF 44_60	P63	BN63B6	124	
15.3	53	3.6	57	5000			WR 63_57	P63	BN63B6	138	
15.6	46	1.9	84	3450			VFR 49_84	P63	BN63A4	BE63A4	132
16.4	36	1.5	80	3150			VF 49_80	P63	BN63A4	BE63A4	130
18.2	42	1.8	72	3430			VFR 49_72	P63	BN63A4	BE63A4	132
18.7	34	0.9	70	3300			VF 44_70	P63	BN63A4	BE63A4	124
18.7	33	1.7	70	3150			VF 49_70	P63	BN63A4	BE63A4	130
21.8	30	1.3	60	2300			VF 44_60	P63	BN63A4	BE63A4	124
21.8	30	1.9	60	3150			VF 49_60	P63	BN63A4	BE63A4	130
24.3	34	2.2	54	3140			VFR 49_54	P63	BN63A4	BE63A4	132
28.5	25	1.5	46	2300			VF 44_46	P63	BN63A4	BE63A4	124
29.0	24	0.9	30	1360			VF 30_30	P63	BN63B6	122	
29.1	25	2.6	45	3040			VF 49_45	P63	BN63A4	BE63A4	130
31	27	2.9	42	2920			VFR 49_42	P63	BN63A4	BE63A4	132
33	21	0.9	40	1360			VF 30_40	P63	BN63A4	BE63A4	122
36	21	3.3	36	2830			VF 49_36	P63	BN63A4	BE63A4	130
37	21	1.9	35	2300			VF 44_35	P63	BN63A4	BE63A4	124
44	17	1.2	30	1250			VF 30_30	P63	BN63A4	BE63A4	122
47	17	2.2	28	2300			VF 44_28	P63	BN63A4	BE63A4	124
58	15	1.4	15	1130			VF 30_15	P63	BN63B6	122	
62	14	2.7	14	2150			VF 44_14	P63	BN63B6	124	
66	13	1.4	20	1110			VF 30_20	P63	BN63A4	BE63A4	122
66	13	2.9	20	2100			VF 44_20	P63	BN63A4	BE63A4	124
87	10	1.8	15	1020			VF 30_15	P63	BN63A4	BE63A4	122
94	10	2.9	14	1870			VF 44_14	P63	BN63A4	BE63A4	124
124	8	2.4	7	900			VF 30_7	P63	BN63B6	122	
131	7	2.3	10	900			VF 30_10	P63	BN63A4	BE63A4	122
138	6	1.1	20	560			VF 27_20	P27	BN27C2	121	
138	7	2.2	20	840			VF 30_20	P56	BN56B2	122	
183	5	1.4	15	520			VF 27_15	P27	BN27C2	121	
187	5	3.1	7	810			VF 30_7	P63	BN63A4	BE63A4	122
275	4	2.0	10	460			VF 27_10	P27	BN27C2	121	
275	4	3.4	10	740			VF 30_10	P56	BN56B2	122	
393	3	2.8	7	410			VF 27_7	P27	BN27C2	121	
393	3	4.7	7	660			VF 30_7	P56	BN56B2	122	

0.12 kW

n ₂ min ⁻¹	M ₂ Nm	S	i	R _{n2} N	 IE3			 IEC IE3		
0.31	775	1.4	2800	8000			VF/W 49/110_2800	P63	BXN63MA4	151
0.47	588	1.7	2800	8000						
0.53	654	1.6	1656	8000			VF/W 44/86_2116	P63	BXN63MA4	147
0.62	518	1.0	2116	7000			VF/W 49/110_2070	P63	BXN63MA4	151
0.63	507	2.0	2070	8000						
0.71	483	1.0	1840	7000			VF/W 44/86_1840	P63	BXN63MA4	147
0.79	435	2.3	1656	8000			VF/W 49/110_1656	P63	BXN63MA4	151
0.95	386	1.3	1380	7000			VF/W 44/86_1380	P63	BXN63MA4	147
0.97	354	2.8	1350	8000			VF/W 49/110_1350	P63	BXN63MA4	151
1.2	293	3.4	1080	8000			VF/W 49/110_1080	P63	BXN63MA4	151
1.4	322	1.1	920	5750			VF/W 44/75_920	P63	BXN63MA4	143
1.4	322	1.6	920	7000			VF/W 44/86_920	P63	BXN63MA4	147
1.5	236	0.9	900	5000			VF/W 30/63_900	P63	BXN63MA4	139
1.8	233	0.9	720	5000			VF/W 30/63_720	P63	BXN63MA4	139
1.9	257	1.4	700	5750			VF/W 44/75_700	P63	BXN63MA4	143
1.9	239	2.1	700	7000			VF/W 44/86_700	P63	BXN63MA4	147
2.3	199	1.1	570	5000			VF/W 30/63_570	P63	BXN63MA4	139
2.5	202	1.8	525	5750			VF/W 44/75_525	P63	BXN63MA4	143
2.5	193	2.6	525	7000			VF/W 44/86_525	P63	BXN63MA4	147
2.9	150	0.9	300	5000						



0.12 kW

n ₂ min ⁻¹	M ₂ Nm	S	i	R _{n2} N	IE3		IE3		
2.9	162	1.2	300	6200					
2.9	178	1.7	300	7000					146
2.9	161	1.3	450	5000			VF/W 30/63_450	P63 BXN63MA4	139
3.3	161	2.3	400	5750			VF/W 44/75_400	P63 BXN63MA4	143
3.3	143	3.5	400	7000			VF/W 44/86_400	P63 BXN63MA4	147
3.6	136	1.0	240	5000					
3.6	142	1.5	240	6200					
3.6	142	1.6	240	5000					
3.6	158	2.0	240	7000					
4.2	110	0.9	315	3450			VF/VF 30/49_315	P63 BXN63MA4	134
4.2	116	1.8	315	5000			VF/W 30/63_315	P63 BXN63MA4	139
4.4	108	1.2	300	5000			WR 63_300	P63 BXN63MA4	138
4.4	115	1.6	300	6200			WR 75_300	P63 BXN63MA4	142
4.4	129	2.1	300	7000			WR 86_300	P63 BXN63MA4	146
4.4	134	2.8	300	5750			VF/W 44/75_300	P63 BXN63MA4	143
4.8	121	2.3	180	6200					
5.2	126	3.1	168	7000					
5.2	125	3.0	250	5750			VF/W 44/75_250	P63 BXN63MA4	143
5.5	94	1.0	240	3450			VF/VF 30/49_240	P63 BXN63MA4	134
5.5	97	1.4	240	5000			WR 63_240	P63 BXN63MA4	138
5.5	103	2.1	240	6200			WR 75_240	P63 BXN63MA4	142
5.5	99	2.1	240	5000			VF/W 30/63_240	P63 BXN63MA4	139
5.5	111	2.7	240	7000			WR 86_240	P63 BXN63MA4	146
5.8	109	2.9	150	6200					
6.4	89	0.9	135	3300					
6.4	96	1.9	135	5000					
6.8	86	1.8	192	5000			WR 63_192	P63 BXN63MA4	138
7.3	76	0.9	180	3300			VFR 49_180	P63 BXN63MA4	132
7.3	87	2.7	180	6200			WR 75_180	P63 BXN63MA4	142
8.7	55	0.9	100	3300					
9.7	64	1.4	135	3450			VFR 49_135	P63 BXN63MA4	132
9.7	68	2.5	135	5000			WR 63_135	P63 BXN63MA4	138
10.9	50	1.2	80	3300					
11.5	61	3.0	114	5000			WR 63_114	P63 BXN63MA4	138
12.1	55	1.5	108	3450			VFR 49_108	P63 BXN63MA4	132
13.1	41	1.2	100	3150			VF 49_100	P63 BXN63MA4	130
14.5	43	1.1	60	2300					
15.3	53	3.6	57	5000					
15.6	46	1.9	84	3450			VFR 49_84	P63 BXN63MA4	132
16.4	36	1.5	80	3150			VF 49_80	P63 BXN63MA4	130
18.2	42	1.8	72	3430			VFR 49_72	P63 BXN63MA4	132
18.7	34	0.9	70	3300			VF 44_70	P63 BXN63MA4	124
18.7	33	1.7	70	3150			VF 49_70	P63 BXN63MA4	130
21.8	30	1.3	60	2300			VF 44_60	P63 BXN63MA4	124
21.8	30	1.9	60	3150			VF 49_60	P63 BXN63MA4	130
24.3	34	2.2	54	3140			VFR 49_54	P63 BXN63MA4	132
28.5	25	1.5	46	2300			VF 44_46	P63 BXN63MA4	124
29.0	24	0.9	30	1360					
29.1	25	2.6	45	3040			VF 49_45	P63 BXN63MA4	130
31	27	2.9	42	2920			VFR 49_42	P63 BXN63MA4	132
33	21	0.9	40	1360			VF 30_40	P63 BXN63MA4	122
36	21	3.3	36	2830			VF 49_36	P63 BXN63MA4	130
37	21	1.9	35	2300			VF 44_35	P63 BXN63MA4	124
44	17	1.2	30	1250			VF 30_30	P63 BXN63MA4	122
47	17	2.2	28	2300			VF 44_28	P63 BXN63MA4	124
58	15	1.4	15	1130					
62	14	2.7	14	2150					
66	13	1.4	20	1110			VF 30_20	P63 BXN63MA4	122
66	13	2.9	20	2100			VF 44_20	P63 BXN63MA4	124
87	10	1.8	15	1020			VF 30_15	P63 BXN63MA4	122
94	10	2.9	14	1870			VF 44_14	P63 BXN63MA4	124
124	8	2.4	7	900					
131	7	2.3	10	900			VF 30_10	P63 BXN63MA4	122
138	6	1.1	20	560					
138	7	2.2	20	840					
183	5	1.4	15	520					
187	5	3.1	7	810			VF 30_7	P63 BXN63MA4	122
275	4	2.0	10	460					
275	4	3.4	10	740					
393	3	2.8	7	410					
393	3	4.7	7	660					

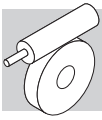





0.18 kW



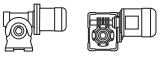

n ₂ min-1	M ₂ Nm	S	i	R _{n2} N								
					IE1	IE2		IE1	IE2			
0.28	978	1.9	3200	13800				W/VF 63/130_3200	P71	BN71A6		158
0.28	1345	3.3	3200	19500				W/VF 86/185_3200	P71	BN71A6		174
0.31	1406	1.9	2944	16000				W/VF 86/150_2944	P71	BN71A6		166
0.35	1027	1.8	2560	13800				W/VF 63/130_2560	P71	BN71A6		158
0.35	1320	3.3	2560	19500				W/VF 86/185_2560	P71	BN71A6		174
0.47	875	1.1	2800	8000				VF/W 49/110_2800	P63	BN63B4	BE63B4	151
0.49	1265	2.1	1840	16000				W/VF 86/150_1840	P71	BN71A6		166
0.50	894	2.1	1800	13800				W/VF 63/130_1800	P71	BN71A6		158
0.54	949	1.1	1656	8000				VF/W 49/110_1656	P71	BN71A6		151
0.59	871	2.1	1520	13800				W/VF 63/130_1520	P71	BN71A6		158
0.64	755	1.3	2070	8000				VF/W 49/110_2070	P63	BN63B4	BE63B4	151
0.65	1054	2.6	1380	16000				W/VF 86/150_1380	P71	BN71A6		166
0.75	733	2.5	1200	13800				W/VF 63/130_1200	P71	BN71A6		158
0.80	647	1.5	1656	8000				VF/W 49/110_1656	P63	BN63B4	BE63B4	151
0.94	642	2.9	960	13800				W/VF 63/130_960	P71	BN71A6		158
0.98	527	1.9	1350	8000				VF/W 49/110_1350	P63	BN63B4	BE63B4	151
0.98	756	3.6	920	16000				W/VF 86/150_920	P71	BN71A6		166
1.2	537	3.4	760	13800				W/VF 63/130_760	P71	BN71A6		158
1.2	436	2.3	1080	8000				VF/W 49/110_1080	P63	BN63B4	BE63B4	151
1.4	479	1.0	920	7000				VF/W 44/86_920	P63	BN63B4	BE63B4	147
1.7	391	1.4	525	7000				VF/W 44/86_525	P71	BN71A6		147
1.8	375	2.7	720	8000				VF/W 49/110_720	P63	BN63B4	BE63B4	151
1.9	356	1.4	700	7000				VF/W 44/86_700	P63	BN63B4	BE63B4	147
2.3	321	1.2	400	5750				VF/W 44/75_400	P71	BN71A6		143
2.3	313	1.8	400	7000				VF/W 44/86_400	P71	BN71A6		147
2.3	344	3.1	400	8000				VF/W 49/110_400	P71	BN71A6		151
2.4	288	3.5	540	8000				VF/W 49/110_540	P63	BN63B4	BE63B4	151
2.5	301	1.2	525	5750				VF/W 44/75_525	P63	BN63B4	BE63B4	143
2.5	287	1.7	525	7000				VF/W 44/86_525	P63	BN63B4	BE63B4	147
3.0	258	1.2	300	7000				WR 86_300	P71	BN71A6		146
3.0	264	1.5	300	5750				VF/W 44/75_300	P71	BN71A6		143
3.0	275	2.1	300	8000				WR 110_300	P71	BN71A6		150
3.0	241	2.3	300	7000				VF/W 44/86_300	P71	BN71A6		147
3.0	269	3.9	300	8000				VF/W 49/110_300	P71	BN71A6		151
3.3	240	1.5	400	5750				VF/W 44/75_400	P63	BN63B4	BE63B4	143
3.3	214	2.3	400	7000				VF/W 44/86_400	P63	BN63B4	BE63B4	147
3.8	206	1.1	240	6200				WR 75_240	P71	BN71A6		142
3.8	229	1.4	240	7000				WR 86_240	P71	BN71A6		146
3.8	243	2.4	240	8000				WR 110_240	P71	BN71A6		150
3.9	233	2.4	230	7000				VF/W 44/86_230	P71	BN71A6		147
4.2	172	1.2	315	5000				VF/W 30/63_315	P63	BN63B4	BE63B4	139
4.4	172	1.0	300	6200				WR 75_300	P63	BN63B4	BE63B4	142
4.4	191	1.4	300	7000				WR 86_300	P63	BN63B4	BE63B4	146
4.4	199	1.9	300	5750				VF/W 44/75_300	P63	BN63B4	BE63B4	143
4.4	176	2.8	300	7000				VF/W 44/86_300	P63	BN63B4	BE63B4	147
4.7	202	1.9	192	7000				WR 86_192	P71	BN71A6		146
5.0	175	1.6	180	6200				WR 75_180	P71	BN71A6		142
5.3	186	2.0	250	5750				VF/W 44/75_250	P63	BN63B4	BE63B4	143
5.4	183	2.1	168	7000				WR 86_168	P71	BN71A6		146
5.5	144	0.9	240	5000				WR 63_240	P63	BN63B4	BE63B4	138
5.5	153	1.4	240	6200				WR 75_240	P63	BN63B4	BE63B4	142
5.5	147	1.4	240	5000				VF/W 30/63_240	P63	BN63B4	BE63B4	139
5.5	166	1.8	240	7000				WR 86_240	P63	BN63B4	BE63B4	146
5.7	162	3.1	230	7000				VF/W 44/86_230	P63	BN63B4	BE63B4	147
6.0	158	2.0	150	6200				WR 75_150	P71	BN71A6		142
6.5	161	2.7	138	7000				WR 86_138	P71	BN71A6		146
6.9	128	1.2	192	5000				WR 63_192	P63	BN63B4	BE63B4	138
6.9	145	2.3	192	7000				WR 86_192	P63	BN63B4	BE63B4	146
7.3	129	1.8	180	6200				WR 75_180	P63	BN63B4	BE63B4	142
7.5	138	2.4	120	6200				WR 75_120	P71	BN71A6		142
7.9	131	2.7	168	7000				WR 86_168	P63	BN63B4	BE63B4	146
7.9	126	1.6	114	5000				WR 63_114	P71	BN71A6		138
8.8	113	2.3	150	6200				WR 75_150	P63	BN63B4	BE63B4	142
9.0	88	1.4	100	5000	W 63_100 S1	M1SC6	136	W 63_100	P71	BN71A6		138
9.0	96	1.7	100	6200	W 75_100 S1	M1SC6	140	W 75_100	P71	BN71A6		141
9.0	105	2.4	100	7000	W 86_100 S1	M1SC6	144	W 86_100	P71	BN71A6		145
9.8	102	1.7	135	5000				WR 63_135	P63	BN63B4	BE63B4	138
10.0	107	1.9	90	5000				WR 63_90	P71	BN71A6		138
11.0	98	3.1	120	6200				WR 75_120	P63	BN63B4	BE63B4	142
11.3	79	1.6	80	5000	W 63_80 S1	M1SC6	136	W 63_80	P71	BN71A6		138
11.3	83	2.4	80	6200	W 75_80 S1	M1SC6	140	W 75_80	P71	BN71A6		141
11.3	90	3.1	80	7000	W 86_80 S1	M1SC6	144	W 86_80	P71	BN71A6		145
11.6	91	2.0	114	5000				WR 63_114	P63	BN63B4	BE63B4	138
12.0	100	3.3	75	6200				WR 75_75	P71	BN71A6		142
12.2	82	1.0	108	3450				VFR 49_108	P63	BN63B4	BE63B4	132
14.7	75	2.5	90	5000				WR 63_90	P63	BN63B4	BE63B4	138

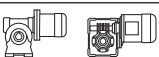

0.18 kW

n ₂ min-1	M ₂ Nm	S	i	R _{n2} N	 IE1 IE2			 IEC IE1 IE2				
15.0	61	1.1	60	3000				VF 49_60	P71	BN71A6	130	
15.0	60	1.1	180	3300				VFR 49_180	P63	BN63A2	132	
15.7	68	1.3	84	3420				VFR 49_84	P63	BN63B4	BE63B4	132
16.5	54	1.0	80	3150				VF 49_80	P63	BN63B4	BE63B4	130
18.3	63	1.2	72	3270				VFR 49_72	P63	BN63B4	BE63B4	132
18.3	66	2.8	72	5000				WR 63_72	P63	BN63B4	BE63B4	138
18.9	49	1.1	70	3150				VF 49_70	P63	BN63B4	BE63B4	130
20.0	50	1.4	135	3280				VFR 49_135	P63	BN63A2		132
20.0	54	2.9	45	5000				W 63_45	P71	BN71A6		138
22.0	45	0.9	60	2300				VF 44_60	P63	BN63B4	BE63B4	124
22.0	45	1.3	60	3150				VF 49_60	P63	BN63B4	BE63B4	130
23.2	54	3.3	57	4910				WR 63_57	P63	BN63B4	BE63B4	138
24.4	50	1.5	54	3010				VFR 49_54	P63	BN63B4	BE63B4	132
28.7	38	1.0	46	2500				VF 44_46	P63	BN63B4	BE63B4	124
29.3	37	1.8	45	2300				VF 49_45	P63	BN63B4	BE63B4	130
31	40	1.9	42	2810				VFR 49_42	P63	BN63B4	BE63B4	132
32	36	1.4	28	2290				VF 44_28	P71	BN71A6		124
37	31	2.2	36	2760				VF 49_36	P63	BN63B4	BE63B4	130
38	31	1.3	35	2430				VF 44_35	P63	BN63B4	BE63B4	124
47	26	1.5	28	2270				VF 44_28	P63	BN63B4	BE63B4	124
47	26	2.9	28	2560				VF 49_28	P63	BN63B4	BE63B4	130
55	23	2.7	24	2430				VF 49_24	P63	BN63B4	BE63B4	130
66	19	0.9	20	1040				VF 30_20	P63	BN63B4	BE63B4	122
66	20	1.9	20	2040				VF 44_20	P63	BN63B4	BE63B4	124
73	18	3.2	18	2230				VF 49_18	P63	BN63B4	BE63B4	130
77	16	1.8	35	1970				VF 44_35	P63	BN63A2		124
88	15	1.2	15	960				VF 30_15	P63	BN63B4	BE63B4	122
94	15	2.0	14	1830				VF 44_14	P63	BN63B4	BE63B4	124
132	11	1.5	10	860				VF 30_10	P63	BN63B4	BE63B4	122
132	11	2.7	10	1640				VF 44_10	P63	BN63B4	BE63B4	124
189	8	2.1	7	770				VF 30_7	P63	BN63B4	BE63B4	122
193	7	2.9	14	1470				VF 44_14	P63	BN63A2		124
270	5	2.2	10	710				VF 30_10	P63	BN63A2		122
386	4	3.1	7	640				VF 30_7	P63	BN63A2		122

0.18 kW

n ₂ min-1	M ₂ Nm	S	i	R _{n2} N	 IE3			 IEC IE3			
0.28	978	1.9	3200	13800							
0.28	1345	3.3	3200	19500							
0.31	1406	1.9	2944	16000							
0.35	1027	1.8	2560	13800							
0.35	1320	3.3	2560	19500							
0.47	875	1.1	2800	8000				VF/W 49/110_2800	P63	BXN63MB4	151
0.49	1265	2.1	1840	16000							
0.50	894	2.1	1800	13800							
0.54	949	1.1	1656	8000							
0.59	871	2.1	1520	13800							
0.64	755	1.3	2070	8000				VF/W 49/110_2070	P63	BXN63MB4	151
0.65	1054	2.6	1380	16000							
0.75	733	2.5	1200	13800							
0.80	647	1.5	1656	8000				VF/W 49/110_1656	P63	BXN63MB4	151
0.94	642	2.9	960	13800							
0.98	527	1.9	1350	8000				VF/W 49/110_1350	P63	BXN63MB4	151
0.98	756	3.6	920	16000							
1.2	537	3.4	760	13800							
1.2	436	2.3	1080	8000				VF/W 49/110_1080	P63	BXN63MB4	151
1.4	479	1.0	920	7000				VF/W 44/86_920	P63	BXN63MB4	147
1.7	391	1.4	525	7000							
1.8	375	2.7	720	8000				VF/W 49/110_720	P63	BXN63MB4	151
1.9	356	1.4	700	7000				VF/W 44/86_700	P63	BXN63MB4	147
2.3	321	1.2	400	5750							
2.3	313	1.8	400	7000							
2.3	344	3.1	400	8000							
2.4	288	3.5	540	8000				VF/W 49/110_540	P63	BXN63MB4	151
2.5	301	1.2	525	5750				VF/W 44/75_525	P63	BXN63MB4	143
2.5	287	1.7	525	7000				VF/W 44/86_525	P63	BXN63MB4	147
3.0	258	1.2	300	7000							
3.0	264	1.5	300	5750							
3.0	275	2.1	300	8000							
3.0	241	2.3	300	7000							



0.18 kW

n ₂ min ⁻¹	M ₂ Nm	S	i	R _{n2} N	IE3		IEC		
3.0	269	3.9	300	8000					
3.3	240	1.5	400	5750					
3.3	214	2.3	400	7000					
3.8	206	1.1	240	6200					
3.8	229	1.4	240	7000					
3.8	243	2.4	240	8000					
3.9	233	2.4	230	7000					
4.2	172	1.2	315	5000					
4.4	172	1.0	300	6200					
4.4	191	1.4	300	7000					
4.4	199	1.9	300	5750					
4.4	176	2.8	300	7000					
4.7	202	1.9	192	7000					
5.0	175	1.6	180	6200					
5.3	186	2.0	250	5750					
5.4	183	2.1	168	7000					
5.5	144	0.9	240	5000					
5.5	153	1.4	240	6200					
5.5	147	1.4	240	5000					
5.5	166	1.8	240	7000					
5.7	162	3.1	230	7000					
6.0	158	2.0	150	6200					
6.5	161	2.7	138	7000					
6.9	128	1.2	192	5000					
6.9	145	2.3	192	7000					
7.3	129	1.8	180	6200					
7.5	138	2.4	120	6200					
7.9	131	2.7	168	7000					
7.9	126	1.6	114	5000					
8.8	113	2.3	150	6200					
9.0	88	1.4	100	5000					
9.0	96	1.7	100	6200					
9.0	105	2.4	100	7000					
9.8	102	1.7	135	5000					
10.0	107	1.9	90	5000					
11.0	98	3.1	120	6200					
11.3	79	1.6	80	5000					
11.3	83	2.4	80	6200					
11.3	90	3.1	80	7000					
11.6	91	2.0	114	5000					
12.0	100	3.3	75	6200					
12.2	82	1.0	108	3450					
14.7	75	2.5	90	5000					
15.0	61	1.1	60	3000					
15.0	60	1.1	180	3300					
15.7	68	1.3	84	3420					
16.5	54	1.0	80	3150					
18.3	63	1.2	72	3270					
18.3	66	2.8	72	5000					
18.9	49	1.1	70	3150					
20.0	50	1.4	135	3280					
20.0	54	2.9	45	5000					
22.0	45	0.9	60	2300					
22.0	45	1.3	60	3150					
23.2	54	3.3	57	4910					
24.4	50	1.5	54	3010					
28.7	38	1.0	46	2500					
29.3	37	1.8	45	2300					
31	40	1.9	42	2810					
32	36	1.4	28	2290					
37	31	2.2	36	2760					
38	31	1.3	35	2430					
47	26	1.5	28	2270					
47	26	2.9	28	2560					
55	23	2.7	24	2430					
66	19	0.9	20	1040					
66	20	1.9	20	2040					
73	18	3.2	18	2230					
77	16	1.8	35	1970					
88	15	1.2	15	960					
94	15	2.0	14	1830					
132	11	1.5	10	860					
132	11	2.7	10	1640					
189	8	2.1	7	770					
193	7	2.9	14	1470					
270	5	2.2	10	710					
386	4	3.1	7	640					

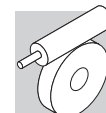





0.25 kW



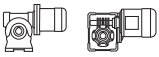

n ₂ min ⁻¹	M ₂ Nm	S	i	R _{n2} N								
					IE1	IE2		IE1	IE2			
0.28	1358	1.4	3200	13800				W/VF 63/130_3200	P71	BN71B6		158
0.28	1868	2.4	3200	19500				W/VF 86/185_3200	P71	BN71B6		174
0.31	1952	1.4	2944	16000				W/VF 86/150_2944	P71	BN71B6		166
0.43	945	1.9	3200	13800				W/VF 63/130_3200	P71	BN71A4	BE71A4	158
0.43	1334	3.1	3200	19500				W/VF 86/185_3200	P71	BN71A4	BE71A4	174
0.47	1380	1.9	2944	16000				W/VF 86/150_2944	P71	BN71A4	BE71A4	166
0.49	1562	2.8	1840	19500				W/VF 86/185_1840	P71	BN71B6		174
0.54	1022	1.8	2560	13800				W/VF 63/130_2560	P71	BN71A4	BE71A4	158
0.54	1289	3.3	2560	19500				W/VF 86/185_2560	P71	BN71A4	BE71A4	174
0.65	1464	1.8	1380	16000				W/VF 86/150_1380	P71	BN71B6		166
0.66	1006	1.0	2070	8000				VF/W 49/110_2070	P71	BN71A4	BE71A4	151
0.75	1214	2.1	1840	16000				W/VF 86/150_1840	P71	BN71A4	BE71A4	166
0.75	1019	1.8	1200	13800				W/VF 63/130_1200	P71	BN71B6		158
0.76	875	2.1	1800	13800				W/VF 63/130_1800	P71	BN71A4	BE71A4	158
0.83	863	1.2	1656	8000				VF/W 49/110_1656	P71	BN71A4	BE71A4	151
0.90	845	2.1	1520	13800				W/VF 63/130_1520	P71	BN71A4	BE71A4	158
0.98	1049	2.6	920	16000				W/VF 86/150_920	P71	BN71B6		166
1.0	1006	2.6	1380	16000				W/VF 86/150_1380	P71	BN71A4	BE71A4	166
1.0	703	1.4	1350	8000				VF/W 49/110_1350	P71	BN71A4	BE71A4	151
1.1	708	2.5	1200	13800				W/VF 63/130_1200	P71	BN71A4	BE71A4	158
1.2	746	2.5	760	13800				W/VF 63/130_760	P71	BN71B6		158
1.3	581	1.7	1080	8000				VF/W 49/110_1080	P71	BN71A4	BE71A4	151
1.3	860	3.1	690	16000				W/VF 86/150_690	P71	BN71B6		166
1.4	617	2.9	960	13800				W/VF 63/130_960	P71	BN71A4	BE71A4	158
1.7	544	1.9	540	8000				VF/W 49/110_540	P71	BN71B6		151
1.7	543	1.0	525	7000				VF/W 44/86_525	P71	BN71B6		147
1.8	515	3.5	760	13800				W/VF 63/130_760	P71	BN71A4	BE71A4	158
1.9	500	2.0	720	8000				VF/W 49/110_720	P71	BN71A4	BE71A4	151
2.0	474	1.1	700	7000				VF/W 44/86_700	P71	BN71A4	BE71A4	147
2.5	384	2.6	540	8000				VF/W 49/110_540	P71	BN71A4	BE71A4	151
2.6	383	1.3	525	7000				VF/W 44/86_525	P71	BN71A4	BE71A4	147
3.0	366	1.1	300	5750				VF/W 44/75_300	P71	BN71B6		143
3.0	382	1.5	300	8000				WR 110_300	P71	BN71B6		150
3.0	374	2.8	300	8000				VF/W 49/110_300	P71	BN71B6		151
3.4	319	1.2	400	5750				VF/W 44/75_400	P71	BN71A4	BE71A4	143
3.4	285	1.8	400	7000				VF/W 44/86_400	P71	BN71A4	BE71A4	147
3.4	313	3.2	400	8000				VF/W 49/110_400	P71	BN71A4	BE71A4	151
3.8	318	1.0	240	7000				WR 86_240	P71	BN71B6		146
3.8	337	1.7	240	8000				WR 110_240	P71	BN71B6		150
3.9	323	1.7	230	7000				VF/W 44/86_230	P71	BN71B6		147
3.9	311	3.4	230	8000				VF/W 49/110_230	P71	BN71B6		151
4.6	255	1.1	300	7000				WR 86_300	P71	BN71A4	BE71A4	146
4.6	266	1.4	300	5750				VF/W 44/75_300	P71	BN71A4	BE71A4	143
4.6	266	2.1	300	8000				WR 110_300	P71	BN71A4	BE71A4	150
4.6	234	2.1	300	7000				VF/W 44/86_300	P71	BN71A4	BE71A4	147
4.7	280	1.4	192	7000				WR 86_192	P71	BN71B6		146
5.5	247	1.5	250	5750				VF/W 44/75_250	P71	BN71A4	BE71A4	143
5.7	204	1.1	240	6200				WR 75_240	P71	BN71A4	BE71A4	142
5.7	221	1.4	240	7000				WR 86_240	P71	BN71A4	BE71A4	146
5.7	233	2.4	240	8000				WR 110_240	P71	BN71A4	BE71A4	150
6.0	216	2.3	230	7000				VF/W 44/86_230	P71	BN71A4	BE71A4	147
6.0	219	1.4	150	6200				WR 75_150	P71	BN71B6		142
6.7	193	0.9	135	5000				WR 63_135	P71	BN71B6		138
7.2	193	1.7	192	7000				WR 86_192	P71	BN71A4	BE71A4	146
7.2	200	3.1	192	8000				WR 110_192	P71	BN71A4	BE71A4	150
7.6	172	1.4	180	6200				WR 75_180	P71	BN71A4	BE71A4	142
7.9	175	1.1	114	5000				WR 63_114	P71	BN71B6		138
8.2	175	2.0	168	7000				WR 86_168	P71	BN71A4	BE71A4	146
9.0	122	1.0	100	5000	W 63_100 S1	M1SD6	136					
9.0	133	1.2	100	6200	W 75_100 S1	M1SD6	140	W 75_100	P71	BN71B6		141
9.0	146	1.7	100	7000	W 86_100 S1	M1SD6	144	W 86_100	P71	BN71B6		145
9.2	151	1.7	150	6200				WR 75_150	P71	BN71A4	BE71A4	142
10.0	151	2.7	138	7000				WR 86_138	P71	BN71A4	BE71A4	146
10.0	160	2.3	90	6200				WR 75_90	P71	BN71B6		142
10.2	136	1.3	135	5000				WR 63_135	P71	BN71A4	BE71A4	138
11.3	110	1.1	80	5000	W 63_80 S1	M1SD6	136					
11.3	115	1.7	80	6200	W 75_80 S1	M1SD6	140	W 75_80	P71	BN71B6		141
11.3	125	2.2	80	7000	W 86_80 S1	M1SD6	144	W 86_80	P71	BN71B6		145
11.5	131	2.3	120	6200				WR 75_120	P71	BN71A4	BE71A4	142
11.5	138	2.8	120	7000				WR 86_120	P71	BN71A4	BE71A4	146
12.1	121	1.5	114	5000				WR 63_114	P71	BN71A4	BE71A4	138
13.8	89	1.3	100	5000				W 63_100	P71	BN71A4	BE71A4	138
13.8	96	1.6	100	6200				W 75_100	P71	BN71A4	BE71A4	141
13.8	102	2.2	100	7000				W 86_100	P71	BN71A4	BE71A4	145
15.3	100	1.9	90	5000				WR 63_90	P71	BN71A4	BE71A4	138
15.3	108	3.0	90	6200				WR 75_90	P71	BN71A4	BE71A4	142



0.25 kW

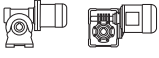



n ₂ min-1	M ₂ Nm	S	i	R _{n2} N	 IE1 IE2			 IEC IE1 IE2				
					17.2	78		1.5	80	5000		
17.2	82	2.2	80	6200				W 75_80	P71	BN71A4	BE71A4	141
17.2	89	2.9	80	7000				W 86_80	P71	BN71A4	BE71A4	145
18.3	95	3.1	75	6200				WR 75_75	P71	BN71A4	BE71A4	142
19.1	88	2.1	72	5000				WR 63_72	P71	BN71A4	BE71A4	138
21.5	68	1.8	64	5000				W 63_64	P71	BN71A4	BE71A4	138
22.9	68	3.0	60	6200				W 75_60	P71	BN71A4	BE71A4	141
24.1	72	2.5	57	4780				WR 63_57	P71	BN71A4	BE71A4	138
31	52	2.8	45	4550				W 63_45	P71	BN71A4	BE71A4	138
31	59	3.0	45	4460				WR 63_45	P71	BN71A4	BE71A4	138
32	50	1.0	28	2300				VF 44_28	P71	BN71B6		124
36	46	3.4	38	4320				W 63_38	P71	BN71A4	BE71A4	138
37	44	1.6	36	2670				VF 49_36	P71	BN71A4	BE71A4	130
38	43	0.9	35	2300				VF 44_35	P71	BN71A4	BE71A4	124
38	49	3.3	36	4160				WR 63_36	P71	BN71A4	BE71A4	138
45	39	1.1	20	2190				VF 44_20	P71	BN71B6		124
47	36	1.1	28	2190				VF 44_28	P71	BN71A4	BE71A4	124
47	36	2.1	28	2480				VF 49_28	P71	BN71A4	BE71A4	130
55	33	1.9	24	2360				VF 49_24	P71	BN71A4	BE71A4	130
64	29	1.3	14	1980				VF 44_14	P71	BN71B6		124
64	29	2.5	14	2260				VF 49_14	P71	BN71B6		130
66	28	1.4	20	1970				VF 44_20	P71	BN71A4	BE71A4	124
73	25	2.3	18	2170				VF 49_18	P71	BN71A4	BE71A4	130
77	23	1.3	35	1930				VF 44_35	P63	BN63B2		124
90	22	1.8	10	1780				VF 44_10	P71	BN71B6		124
90	22	2.9	10	2040				VF 49_10	P71	BN71B6		130
94	21	1.4	14	1770				VF 44_14	P71	BN71A4	BE71A4	124
94	21	3.2	14	2010				VF 49_14	P71	BN71A4	BE71A4	130
113	17	2.8	24	1930				VF 49_24	P63	BN63B2		130
129	16	2.5	7	1590				VF 44_7	P71	BN71B6		124
132	15	1.9	10	1590				VF 44_10	P71	BN71A4	BE71A4	124
135	14	1.0	20	840				VF 30_20	P63	BN63B2		122
180	11	1.3	15	780				VF 30_15	P63	BN63B2		122
189	11	2.7	7	1420				VF 44_7	P71	BN71A4	BE71A4	124
270	8	1.6	10	690				VF 30_10	P63	BN63B2		122
270	8	2.9	10	1300				VF 44_10	P63	BN63B2		124
386	5	2.2	7	620				VF 30_7	P63	BN63B2		122

0.25 kW

n ₂ min-1	M ₂ Nm	S	i	R _{n2} N	 IE3				 IEC IE3			
					0.28	1358	1.4		3200	13800		
0.28	1868	2.4	3200	19500								
0.31	1952	1.4	2944	16000								
0.43	945	1.9	3200	13800	W/VF 63/130_3200	S10	MXN10MA4	158	W/VF 63/130_3200	P71	BXN71MA4	158
0.43	1334	3.1	3200	19500	W/VF 86/185_3200	S10	MXN10MA4	174	W/VF 86/185_3200	P71	BXN71MA4	174
0.47	1380	1.9	2944	16000	W/VF 86/150_2944	S10	MXN10MA4	166	W/VF 86/150_2944	P71	BXN71MA4	166
0.49	1562	2.8	1840	19500								
0.54	1022	1.8	2560	13800	W/VF 63/130_2560	S10	MXN10MA4	158	W/VF 63/130_2560	P71	BXN71MA4	158
0.54	1289	3.3	2560	19500	W/VF 86/185_2560	S10	MXN10MA4	174	W/VF 86/185_2560	P71	BXN71MA4	174
0.65	1464	1.8	1380	16000								
0.66	1006	1.0	2070	8000					VF/W 49/110_2070	P71	BXN71MA4	151
0.75	1214	2.1	1840	16000	W/VF 86/150_1840	S10	MXN10MA4	166	W/VF 86/150_1840	P71	BXN71MA4	166
0.75	1019	1.8	1200	13800								
0.76	875	2.1	1800	13800	W/VF 63/130_1800	S10	MXN10MA4	158	W/VF 63/130_1800	P71	BXN71MA4	158
0.83	863	1.2	1656	8000					VF/W 49/110_1656	P71	BXN71MA4	151
0.90	845	2.1	1520	13800	W/VF 63/130_1520	S10	MXN10MA4	158	W/VF 63/130_1520	P71	BXN71MA4	158
0.98	1049	2.6	920	16000								
1.0	1006	2.6	1380	16000	W/VF 86/150_1380	S10	MXN10MA4	166	W/VF 86/150_1380	P71	BXN71MA4	166
1.0	703	1.4	1350	8000					VF/W 49/110_1350	P71	BXN71MA4	151
1.1	708	2.5	1200	13800	W/VF 63/130_1200	S10	MXN10MA4	158	W/VF 63/130_1200	P71	BXN71MA4	158
1.2	746	2.5	760	13800								
1.3	581	1.7	1080	8000					VF/W 49/110_1080	P71	BXN71MA4	151
1.3	860	3.1	690	16000								
1.4	617	2.9	960	13800	W/VF 63/130_960	S10	MXN10MA4	158	W/VF 63/130_960	P71	BXN71MA4	158
1.7	544	1.9	540	8000								
1.7	543	1.0	525	7000								
1.8	515	3.5	760	13800	W/VF 63/130_760	S10	MXN10MA4	158	W/VF 63/130_760	P71	BXN71MA4	158
1.9	500	2.0	720	8000					VF/W 49/110_720	P71	BXN71MA4	151
2.0	474	1.1	700	7000					VF/W 44/86_700	P71	BXN71MA4	147
2.5	384	2.6	540	8000					VF/W 49/110_540	P71	BXN71MA4	151



0.25 kW

n ₂ min-1	M ₂ Nm	S	i	R _{n2} N	  IE3			  IEC				
					VF/W	P71	BXN71MA4	VF/W	P71	BXN71MA4		
2.6	383	1.3	525	7000				VF/W 44/86_525	P71	BXN71MA4		147
3.0	366	1.1	300	5750								
3.0	382	1.5	300	8000								
3.0	374	2.8	300	8000								
3.4	319	1.2	400	5750				VF/W 44/75_400	P71	BXN71MA4		143
3.4	285	1.8	400	7000				VF/W 44/86_400	P71	BXN71MA4		147
3.4	313	3.2	400	8000				VF/W 49/110_400	P71	BXN71MA4		151
3.8	318	1.0	240	7000								
3.8	337	1.7	240	8000								
3.9	323	1.7	230	7000								
3.9	311	3.4	230	8000								
4.6	255	1.1	300	7000				WR 86_300	P71	BXN71MA4		146
4.6	266	1.4	300	5750				VF/W 44/75_300	P71	BXN71MA4		143
4.6	266	2.1	300	8000				WR 110_300	P71	BXN71MA4		150
4.6	234	2.1	300	7000				VF/W 44/86_300	P71	BXN71MA4		147
4.7	280	1.4	192	7000								
5.5	247	1.5	250	5750				VF/W 44/75_250	P71	BXN71MA4		143
5.7	204	1.1	240	6200				WR 75_240	P71	BXN71MA4		142
5.7	221	1.4	240	7000				WR 86_240	P71	BXN71MA4		146
5.7	233	2.4	240	8000				WR 110_240	P71	BXN71MA4		150
6.0	216	2.3	230	7000				VF/W 44/86_230	P71	BXN71MA4		147
6.0	219	1.4	150	6200								
6.7	193	0.9	135	5000								
7.2	193	1.7	192	7000				WR 86_192	P71	BXN71MA4		146
7.2	200	3.1	192	8000				WR 110_192	P71	BXN71MA4		150
7.6	172	1.4	180	6200				WR 75_180	P71	BXN71MA4		142
7.9	175	1.1	114	5000								
8.2	175	2.0	168	7000				WR 86_168	P71	BXN71MA4		146
9.0	122	1.0	100	5000								
9.0	133	1.2	100	6200								
9.0	146	1.7	100	7000								
9.2	151	1.7	150	6200				WR 75_150	P71	BXN71MA4		142
10.0	151	2.7	138	7000				WR 86_138	P71	BXN71MA4		146
10.0	160	2.3	90	6200								
10.2	136	1.3	135	5000				WR 63_135	P71	BXN71MA4		138
11.3	110	1.1	80	5000								
11.3	115	1.7	80	6200								
11.3	125	2.2	80	7000								
11.5	131	2.3	120	6200				WR 75_120	P71	BXN71MA4		142
11.5	138	2.8	120	7000				WR 86_120	P71	BXN71MA4		146
12.1	121	1.5	114	5000				WR 63_114	P71	BXN71MA4		138
13.8	89	1.3	100	5000	W 63_100	S10	MXN10MA4	138	W 63_100	P71	BXN71MA4	138
13.8	96	1.6	100	6200	W 75_100	S10	MXN10MA4	141	W 75_100	P71	BXN71MA4	141
13.8	102	2.2	100	7000	W 86_100	S10	MXN10MA4	145	W 86_100	P71	BXN71MA4	145
15.3	100	1.9	90	5000				WR 63_90	P71	BXN71MA4		138
15.3	108	3.0	90	6200				WR 75_90	P71	BXN71MA4		142
17.2	78	1.5	80	5000	W 63_80	S10	MXN10MA4	138	W 63_80	P71	BXN71MA4	138
17.2	82	2.2	80	6200	W 75_80	S10	MXN10MA4	141	W 75_80	P71	BXN71MA4	141
17.2	89	2.9	80	7000	W 86_80	S10	MXN10MA4	145	W 86_80	P71	BXN71MA4	145
18.3	95	3.1	75	6200				WR 75_75	P71	BXN71MA4		142
19.1	88	2.1	72	5000				WR 63_72	P71	BXN71MA4		138
21.5	68	1.8	64	5000	W 63_64	S10	MXN10MA4	138	W 63_64	P71	BXN71MA4	138
22.9	68	3.0	60	6200	W 75_60	S10	MXN10MA4	141	W 75_60	P71	BXN71MA4	141
24.1	72	2.5	57	4780				WR 63_57	P71	BXN71MA4		138
31	52	2.8	45	4550	W 63_45	S10	MXN10MA4	138	W 63_45	P71	BXN71MA4	138
31	59	3.0	45	4460				WR 63_45	P71	BXN71MA4		138
32	50	1.0	28	2300								
36	46	3.4	38	4320	W 63_38	S10	MXN10MA4	138	W 63_38	P71	BXN71MA4	138
37	44	1.6	36	2670				VF 49_36	P71	BXN71MA4		130
38	43	0.9	35	2300				VF 44_35	P71	BXN71MA4		124
38	49	3.3	36	4160				WR 63_36	P71	BXN71MA4		138
45	39	1.1	20	2190								
47	36	1.1	28	2190								
47	36	2.1	28	2480				VF 44_28	P71	BXN71MA4		124
55	33	1.9	24	2360				VF 49_28	P71	BXN71MA4		130
55	33	1.9	24	2360				VF 49_24	P71	BXN71MA4		130
64	29	1.3	14	1980								
64	29	2.5	14	2260								
66	28	1.4	20	1970				VF 44_20	P71	BXN71MA4		124
73	25	2.3	18	2170				VF 49_18	P71	BXN71MA4		130
77	23	1.3	35	1930								
90	22	1.8	10	1780								
90	22	2.9	10	2040								
94	21	1.4	14	1770								
94	21	3.2	14	2010				VF 44_14	P71	BXN71MA4		124
113	17	2.8	24	1930				VF 49_14	P71	BXN71MA4		130
129	16	2.5	7	1590								

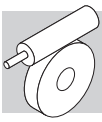

0.25 kW

n ₂ min ⁻¹	M ₂ Nm	S	i	R _{n2} N	 IE3		 IEC			
132	15	1.9	10	1590			VF 44_10	P71	BNX71MA4	124
135	14	1.0	20	840						
180	11	1.3	15	780						
189	11	2.7	7	1420			VF 44_7	P71	BNX71MA4	124
270	8	1.6	10	690						
270	8	2.9	10	1300						
386	5	2.2	7	620						

0.37 kW

n ₂ min ⁻¹	M ₂ Nm	S	i	R _{n2} N	 IE1 IE2		 IEC			
0.28	2734	1.6	3200	19500			W/VF 86/185_3200	P80	BN80A6	174
0.31	2858	0.9	2944	16000			W/VF 86/150_2944	P80	BN80A6	166
0.36	2684	1.6	2560	19500			W/VF 86/185_2560	P80	BN80A6	174
0.43	1403	1.3	3200	13800			W/VF 63/130_3200	P71	BN71B4 BE71B4	158
0.43	1981	2.1	3200	19500			W/VF 86/185_3200	P71	BN71B4 BE71B4	174
0.47	2050	1.3	2944	16000			W/VF 86/150_2944	P71	BN71B4 BE71B4	166
0.54	1519	1.2	2560	13800			W/VF 63/130_2560	P71	BN71B4 BE71B4	158
0.54	1915	2.2	2560	19500			W/VF 86/185_2560	P71	BN71B4 BE71B4	174
0.60	1771	1.0	1520	13800			W/VF 63/130_1520	P80	BN80A6	158
0.66	2143	1.3	1380	16000			W/VF 86/150_1380	P80	BN80A6	166
0.74	1803	1.4	1840	16000			W/VF 86/150_1840	P71	BN71B4 BE71B4	166
0.74	1614	2.6	1840	19500			W/VF 86/185_1840	P71	BN71B4 BE71B4	174
0.76	1300	1.4	1800	13800			W/VF 63/130_1800	P71	BN71B4 BE71B4	158
0.86	1444	2.9	1600	19500			W/VF 86/185_1600	P71	BN71B4 BE71B4	174
0.90	1255	1.4	1520	13800			W/VF 63/130_1520	P71	BN71B4 BE71B4	158
0.99	1357	3.2	920	19500			W/VF 86/185_920	P80	BN80A6	174
1.0	1495	1.7	1380	16000			W/VF 86/150_1380	P71	BN71B4 BE71B4	166
1.0	1045	1.0	1350	8000			VF/W 49/110_1350	P71	BN71B4 BE71B4	151
1.1	1052	1.7	1200	13800			W/VF 63/130_1200	P71	BN71B4 BE71B4	158
1.3	864	1.2	1080	8000			VF/W 49/110_1080	P71	BN71B4 BE71B4	151
1.3	1259	2.1	690	16000			W/VF 86/150_690	P80	BN80A6	166
1.4	916	2.0	960	13800			W/VF 63/130_960	P71	BN71B4 BE71B4	158
1.5	1068	2.4	920	16000			W/VF 86/150_920	P71	BN71B4 BE71B4	166
1.7	797	1.3	540	8000			VF/W 49/110_540	P80	BN80A6	151
1.7	1068	2.5	529	16000			W/VF 86/150_529	P80	BN80A6	166
1.8	764	2.4	760	13800			W/VF 63/130_760	P71	BN71B4 BE71B4	158
1.9	743	1.3	720	8000			VF/W 49/110_720	P71	BN71B4 BE71B4	151
2.0	890	2.9	690	16000			W/VF 86/150_690	P71	BN71B4 BE71B4	166
2.3	619	2.9	600	13800			W/VF 63/130_600	P71	BN71B4 BE71B4	158
2.5	571	1.8	540	8000			VF/W 49/110_540	P71	BN71B4 BE71B4	151
2.6	750	3.5	529	16000			W/VF 86/150_529	P71	BN71B4 BE71B4	166
3.0	559	1.0	300	8000			WR 110_300	P80	BN80A6	150
3.0	571	1.8	300	13800			VFR 130_300	P80	BN80A6	154
3.0	547	1.9	300	8000			VF/W 49/110_300	P80	BN80A6	151
3.4	423	1.2	400	7000			VF/W 44/86_400	P71	BN71B4 BE71B4	147
3.4	464	2.2	400	8000			VF/W 49/110_400	P71	BN71B4 BE71B4	151
3.8	494	1.2	240	8000			WR 110_240	P80	BN80A6	150
3.8	503	2.4	240	13800			VFR 130_240	P80	BN80A6	154
4.0	455	2.3	230	8000			VF/W 49/110_230	P80	BN80A6	151
4.6	395	1.4	300	8000			WR 110_300	P71	BN71B4 BE71B4	150
4.6	348	1.4	300	7000			VF/W 44/86_300	P71	BN71B4 BE71B4	147
4.6	371	2.7	300	8000			VF/W 49/110_300	P71	BN71B4 BE71B4	151
4.7	410	1.0	192	7000			WR 86_192	P80	BN80A6	146
4.7	425	1.6	192	8000			WR 110_192	P80	BN80A6	150
4.7	432	3.0	192	13800			VFR 130_192	P80	BN80A6	154
5.4	372	1.0	168	7000			WR 86_168	P80	BN80A6	146
5.4	391	2.0	168	8000			WR 110_168	P80	BN80A6	150
5.4	391	3.4	168	13800			VFR 130_168	P80	BN80A6	154
5.7	328	0.9	240	7000			WR 86_240	P71	BN71B4 BE71B4	146
5.7	347	1.6	240	8000			WR 110_240	P71	BN71B4 BE71B4	150
6.0	320	1.6	230	7000			VF/W 44/86_230	P71	BN71B4 BE71B4	147
6.0	308	3.2	230	8000			VF/W 49/110_230	P71	BN71B4 BE71B4	151
6.1	320	1.0	150	6200			WR 75_150	P80	BN80A6	142
6.6	327	1.3	138	7000			WR 86_138	P80	BN80A6	146
6.6	338	2.4	138	8000			WR 110_138	P80	BN80A6	150
7.1	287	1.1	192	7000			WR 86_192	P71	BN71B4 BE71B4	146

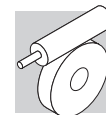



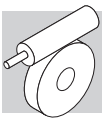

0.37 kW

n ₂ min-1	M ₂ Nm	S	i	R _{n2} N										
					IE1	IE2		IE1	IE2					
7.1	297	2.1	192	8000				WR 110_192	P71	BN71B4	BE71B4	150		
7.6	294	1.5	120	7000				WR 86_120	P80	BN80A6		146		
7.6	303	2.9	120	8000				WR 110_120	P80	BN80A6		150		
7.6	255	0.9	180	6200				WR 75_180	P71	BN71B4	BE71B4	142		
8.2	260	1.4	168	7000				WR 86_168	P71	BN71B4	BE71B4	146		
8.2	273	2.6	168	8000				WR 110_168	P71	BN71B4	BE71B4	150		
9.1	214	1.2	100	7000	W 86_100	S1	M1LA6	144	W 86_100	P80	BN80A6		145	
9.1	224	1.2	150	6200				WR 75_150	P71	BN71B4	BE71B4	142		
9.9	224	1.8	138	7000				WR 86_138	P71	BN71B4	BE71B4	146		
9.9	235	3.0	138	8000				WR 110_138	P71	BN71B4	BE71B4	150		
10.1	234	1.6	90	6200				WR 75_90	P80	BN80A6		142		
11.4	168	1.2	80	6200	W 75_80	S1	M1LA6	140	W 75_80	P80	BN80A6		141	
11.4	183	1.5	80	7000	W 86_80	S1	M1LA6	144	W 86_80	P80	BN80A6		145	
11.4	195	1.6	120	6200				WR 75_120	P71	BN71B4	BE71B4	142		
11.4	204	1.9	120	7000				WR 86_120	P71	BN71B4	BE71B4	146		
12.0	179	1.0	114	5000				WR 63_114	P71	BN71B4	BE71B4	138		
12.1	204	1.6	75	6200				WR 75_75	P80	BN80A6	BN80A6	142		
13.2	196	2.0	69	7000				WR 86_69	P80	BN80A6		146		
13.7	142	1.1	100	6200	W 75_100	S1	M1SD4	ME1SB4	140	W 75_100	P71	BN71B4	BE71B4	141
13.7	152	1.5	100	7000	W 86_100	S1	M1SD4	ME1SB4	144	W 86_100	P71	BN71B4	BE71B4	145
14.2	139	1.0	64	5000	W 63_64	S1	M1LA6		136	W 63_64	P80	BN80A6		138
15.2	140	1.5	60	6200	W 75_60	S1	M1LA6		140	W 75_60	P80	BN80A6		141
15.2	149	1.3	90	5000				WR 63_90	P71	BN71B4	BE71B4		138	
15.2	160	2.0	90	6200				WR 75_90	P71	BN71B4	BE71B4		142	
15.2	156	2.8	90	7000				WR 86_90	P71	BN71B4	BE71B4		146	
16.3	144	2.3	56	7000	W 86_56	S1	M1LA6		144	W 86_56	P80	BN80A6		145
17.1	116	1.0	80	5000	W 63_80	S1	M1SD4	ME1SB4	136	W 63_80	P71	BN71B4	BE71B4	138
17.1	122	1.5	80	6200	W 75_80	S1	M1SD4	ME1SB4	140	W 75_80	P71	BN71B4	BE71B4	141
17.1	132	1.9	80	7000	W 86_80	S1	M1SD4	ME1SB4	144	W 86_80	P71	BN71B4	BE71B4	145
18.3	141	2.1	75	6200				WR 75_75	P71	BN71B4	BE71B4		142	
19.0	130	1.4	72	4830				WR 63_72	P71	BN71B4	BE71B4		138	
19.9	133	2.8	69	7000				WR 86_69	P71	BN71B4	BE71B4		146	
20.2	136	2.6	45	6200				WR 75_45	P80	BN80A6			142	
21.4	101	1.2	64	4870	W 63_64	S1	M1SD4	ME1SB4	136	W 63_64	P71	BN71B4	BE71B4	138
21.4	112	2.5	64	7000	W 86_64	S1	M1SD4	ME1SB4	144	W 86_64	P71	BN71B4	BE71B4	145
22.8	101	2.0	60	6200	W 75_60	S1	M1SD4	ME1SB4	140	W 75_60	P71	BN71B4	BE71B4	141
22.8	119	2.5	60	6200				WR 75_60	P71	BN71B4	BE71B4		142	
22.8	119	3.2	60	7000				WR 86_60	P71	BN71B4	BE71B4		146	
24.0	107	1.7	57	4540				WR 63_57	P71	BN71B4	BE71B4		138	
24.5	101	3.0	56	7000	W 86_56	S1	M1SD4	ME1SB4	144	W 86_56	P71	BN71B4	BE71B4	145
27.4	88	2.5	50	6200	W 75_50	S1	M1SD4	ME1SB4	140	W 75_50	P71	BN71B4	BE71B4	141
30	73	0.9	45	2680				VF 49_45	P71	BN71B4	BE71B4		130	
30	78	1.9	45	4400	W 63_45	S1	M1SD4	ME1SB4	136	W 63_45	P71	BN71B4	BE71B4	138
30	88	2.0	45	4250				WR 63_45	P71	BN71B4	BE71B4		138	
30	93	3.2	45	5880				WR 75_45	P71	BN71B4	BE71B4		142	
34	74	3.4	40	5820	W 75_40	S1	M1SD4	ME1SB4	140	W 75_40	P71	BN71B4	BE71B4	141
36	69	2.3	38	4180	W 63_38	S1	M1SD4	ME1SB4	136	W 63_38	P71	BN71B4	BE71B4	138
38	62	1.1	36	2530				VF 49_36	P71	BN71B4	BE71B4		130	
38	73	2.2	36	3980				WR 63_36	P71	BN71B4	BE71B4		138	
46	57	2.8	30	3900	W 63_30	S1	M1SD4	ME1SB4	136	W 63_30	P71	BN71B4	BE71B4	138
49	51	1.4	28	2360				VF 49_28	P71	BN71B4	BE71B4		130	
57	46	1.4	24	2250				VF 49_24	P71	BN71B4	BE71B4		130	
57	48	3.2	24	3650	W 63_24	S1	M1SD4	ME1SB4	136	W 63_24	P71	BN71B4	BE71B4	138
65	42	1.7	14	1940				VF 49_14	P80	BN80A6			130	
69	40	1.0	20	1870				VF 44_20	P71	BN71B4	BE71B4		124	
72	40	3.8	19	3400	W 63_19	S1	M1SD4	ME1SB4	136	W 63_19	P71	BN71B4	BE71B4	138
76	36	1.6	18	2080				VF 49_18	P71	BN71B4	BE71B4		130	
79	33	0.9	35	1860				VF 44_35	P71	BN71A2			124	
91	32	2.0	10	1930				VF 49_10	P80	BN80A6			130	
98	29	1.0	14	1690				VF 44_14	P71	BN71B4	BE71B4		124	
98	29	2.2	14	1940				VF 49_14	P71	BN71B4	BE71B4		130	
117	24	2.0	24	1880				VF 49_24	P71	BN71A2			130	
137	22	1.3	10	1520				VF 44_10	P71	BN71B4	BE71B4		124	
137	22	2.7	10	1750				VF 49_10	P71	BN71B4	BE71B4		130	
138	21	1.4	20	1570				VF 44_20	P71	BN71A2			124	
153	19	2.3	18	1720				VF 49_18	P71	BN71A2			130	
196	16	1.9	7	1360				VF 44_7	P71	BN71B4	BE71B4		124	
196	16	3.5	7	1570				VF 49_7	P71	BN71B4	BE71B4		130	
275	11	2.0	10	1260				VF 44_10	P71	BN71A2			124	
393	8	2.8	7	1120				VF 44_7	P71	BN71A2			124	









0.37 kW







n ₂ min-1	M ₂ Nm	S	i	R _{n2} N	  IE3			  IEC				
					W/VF	S10	MXN10MB4	W/VF	P71	BXN71MB4		
0.28	2734	1.6	3200	19500								
0.31	2858	0.9	2944	16000								
0.36	2684	1.6	2560	19500								
0.43	1403	1.3	3200	13800	W/VF 63/130_3200	S10	MXN10MB4	158	W/VF 63/130_3200	P71	BXN71MB4	158
0.43	1981	2.1	3200	19500	W/VF 86/185_3200	S10	MXN10MB4	174	W/VF 86/185_3200	P71	BXN71MB4	174
0.47	2050	1.3	2944	16000	W/VF 86/150_2944	S10	MXN10MB4	166	W/VF 86/150_2944	P71	BXN71MB4	166
0.54	1519	1.2	2560	13800	W/VF 63/130_2560	S10	MXN10MB4	158	W/VF 63/130_2560	P71	BXN71MB4	158
0.54	1915	2.2	2560	19500	W/VF 86/185_2560	S10	MXN10MB4	174	W/VF 86/185_2560	P71	BXN71MB4	174
0.60	1771	1.0	1520	13800								
0.66	2143	1.3	1380	16000								
0.74	1803	1.4	1840	16000	W/VF 86/150_1840	S10	MXN10MB4	166	W/VF 86/150_1840	P71	BXN71MB4	166
0.74	1614	2.6	1840	19500	W/VF 86/185_1840	S10	MXN10MB4	174	W/VF 86/185_1840	P71	BXN71MB4	174
0.76	1300	1.4	1800	13800	W/VF 63/130_1800	S10	MXN10MB4	158	W/VF 63/130_1800	P71	BXN71MB4	158
0.86	1444	2.9	1600	19500	W/VF 86/185_1600	S10	MXN10MB4	174	W/VF 86/185_1600	P71	BXN71MB4	174
0.90	1255	1.4	1520	13800	W/VF 63/130_1520	S10	MXN10MB4	158	W/VF 63/130_1520	P71	BXN71MB4	158
0.99	1357	3.2	920	19500								
1.0	1495	1.7	1380	16000	W/VF 86/150_1380	S10	MXN10MB4	166	W/VF 86/150_1380	P71	BXN71MB4	166
1.0	1045	1.0	1350	8000					VF/W 49/110_1350	P71	BXN71MB4	151
1.1	1052	1.7	1200	13800	W/VF 63/130_1200	S10	MXN10MB4	158	W/VF 63/130_1200	P71	BXN71MB4	158
1.3	864	1.2	1080	8000					VF/W 49/110_1080	P71	BXN71MB4	151
1.3	1259	2.1	690	16000								
1.4	916	2.0	960	13800	W/VF 63/130_960	S10	MXN10MB4	158	W/VF 63/130_960	P71	BXN71MB4	158
1.5	1068	2.4	920	16000	W/VF 86/150_920	S10	MXN10MB4	166	W/VF 86/150_920	P71	BXN71MB4	166
1.7	797	1.3	540	8000								
1.7	1068	2.5	529	16000								
1.8	764	2.4	760	13800	W/VF 63/130_760	S10	MXN10MB4	158	W/VF 63/130_760	P71	BXN71MB4	158
1.9	743	1.3	720	8000					VF/W 49/110_720	P71	BXN71MB4	151
2.0	890	2.9	690	16000	W/VF 86/150_690	S10	MXN10MB4	166	W/VF 86/150_690	P71	BXN71MB4	166
2.3	619	2.9	600	13800	W/VF 63/130_600	S10	MXN10MB4	158	W/VF 63/130_600	P71	BXN71MB4	158
2.5	571	1.8	540	8000					VF/W 49/110_540	P71	BXN71MB4	151
2.6	750	3.5	529	16000	W/VF 86/150_529	S10	MXN10MB4	166	W/VF 86/150_529	P71	BXN71MB4	166
3.0	559	1.0	300	8000								
3.0	571	1.8	300	13800								
3.0	547	1.9	300	8000								
3.4	423	1.2	400	7000					VF/W 44/86_400	P71	BXN71MB4	147
3.4	464	2.2	400	8000					VF/W 49/110_400	P71	BXN71MB4	151
3.8	494	1.2	240	8000								
3.8	503	2.4	240	13800								
4.0	455	2.3	230	8000								
4.6	395	1.4	300	8000					WR 110_300	P71	BXN71MB4	150
4.6	348	1.4	300	7000					VF/W 44/86_300	P71	BXN71MB4	147
4.6	371	2.7	300	8000					VF/W 49/110_300	P71	BXN71MB4	151
4.7	410	1.0	192	7000								
4.7	425	1.6	192	8000								
4.7	432	3.0	192	13800								
5.4	372	1.0	168	7000								
5.4	391	2.0	168	8000								
5.4	391	3.4	168	13800								
5.7	328	0.9	240	7000					WR 86_240	P71	BXN71MB4	146
5.7	347	1.6	240	8000					WR 110_240	P71	BXN71MB4	150
6.0	320	1.6	230	7000					VF/W 44/86_230	P71	BXN71MB4	147
6.0	308	3.2	230	8000					VF/W 49/110_230	P71	BXN71MB4	151
6.1	320	1.0	150	6200								
6.6	327	1.3	138	7000								
6.6	338	2.4	138	8000								
7.1	287	1.1	192	7000					WR 86_192	P71	BXN71MB4	146
7.1	297	2.1	192	8000					WR 110_192	P71	BXN71MB4	150
7.6	294	1.5	120	7000								
7.6	303	2.9	120	8000								
7.6	255	0.9	180	6200					WR 75_180	P71	BXN71MB4	142
8.2	260	1.4	168	7000					WR 86_168	P71	BXN71MB4	146
8.2	273	2.6	168	8000					WR 110_168	P71	BXN71MB4	150
9.1	214	1.2	100	7000								
9.1	224	1.2	150	6200					WR 75_150	P71	BXN71MB4	142
9.9	224	1.8	138	7000					WR 86_138	P71	BXN71MB4	146
9.9	235	3.0	138	8000					WR 110_138	P71	BXN71MB4	150
10.1	234	1.6	90	6200								
11.4	168	1.2	80	6200								
11.4	183	1.5	80	7000								
11.4	195	1.6	120	6200					WR 75_120	P71	BXN71MB4	142
11.4	204	1.9	120	7000					WR 86_120	P71	BXN71MB4	146



0.37 kW

n ₂ min-1	M ₂ Nm	S	i	R _{n2} N	 			  				
					IE3			IE3				
12.0	179	1.0	114	5000				WR 63_114	P71	BXN71MB4	138	
12.1	204	1.6	75	6200								
13.2	196	2.0	69	7000								
13.7	142	1.1	100	6200	W 75_100	S10	MXN10MB4	140	W 75_100	P71	BXN71MB4	141
13.7	152	1.5	100	7000	W 86_100	S10	MXN10MB4	144	W 86_100	P71	BXN71MB4	145
14.2	139	1.0	64	5000								
15.2	140	1.5	60	6200								
15.2	149	1.3	90	5000				WR 63_90	P71	BXN71MB4	138	
15.2	160	2.0	90	6200				WR 75_90	P71	BXN71MB4	142	
15.2	156	2.8	90	7000				WR 86_90	P71	BXN71MB4	146	
16.3	144	2.3	56	7000								
17.1	116	1.0	80	5000	W 63_80	S10	MXN10MB4	136	W 63_80	P71	BXN71MB4	138
17.1	122	1.5	80	6200	W 75_80	S10	MXN10MB4	140	W 75_80	P71	BXN71MB4	141
17.1	132	1.9	80	7000	W 86_80	S10	MXN10MB4	144	W 86_80	P71	BXN71MB4	145
18.3	141	2.1	75	6200				WR 75_75	P71	BXN71MB4	142	
19.0	130	1.4	72	4830				WR 63_72	P71	BXN71MB4	138	
19.9	133	2.8	69	7000				WR 86_69	P71	BXN71MB4	146	
20.2	136	2.6	45	6200								
21.4	101	1.2	64	4870	W 63_64	S10	MXN10MB4	136	W 63_64	P71	BXN71MB4	138
21.4	112	2.5	64	7000	W 86_64	S10	MXN10MB4	144	W 86_64	P71	BXN71MB4	145
22.8	101	2.0	60	6200	W 75_60	S10	MXN10MB4	140	W 75_60	P71	BXN71MB4	141
22.8	119	2.5	60	6200				WR 75_60	P71	BXN71MB4	142	
22.8	119	3.2	60	7000				WR 86_60	P71	BXN71MB4	146	
24.0	107	1.7	57	4540				WR 63_57	P71	BXN71MB4	138	
24.5	101	3.0	56	7000	W 86_56	S10	MXN10MB4	144	W 86_56	P71	BXN71MB4	145
27.4	88	2.5	50	6200	W 75_50	S10	MXN10MB4	140	W 75_50	P71	BXN71MB4	141
30	73	0.9	45	2680				VF 49_45	P71	BXN71MB4	130	
30	78	1.9	45	4400	W 63_45	S10	MXN10MB4	136	W 63_45	P71	BXN71MB4	138
30	88	2.0	45	4250				WR 63_45	P71	BXN71MB4	138	
30	93	3.2	45	5880				WR 75_45	P71	BXN71MB4	142	
34	74	3.4	40	5820	W 75_40	S10	MXN10MB4	140	W 75_40	P71	BXN71MB4	141
36	69	2.3	38	4180	W 63_38	S10	MXN10MB4	136	W 63_38	P71	BXN71MB4	138
38	62	1.1	36	2530				VF 49_36	P71	BXN71MB4	130	
38	73	2.2	36	3980				WR 63_36	P71	BXN71MB4	138	
46	57	2.8	30	3900	W 63_30	S10	MXN10MB4	136	W 63_30	P71	BXN71MB4	138
49	51	1.4	28	2360				VF 49_28	P71	BXN71MB4	130	
57	46	1.4	24	2250				VF 49_24	P71	BXN71MB4	130	
57	48	3.2	24	3650	W 63_24	S10	MXN10MB4	136	W 63_24	P71	BXN71MB4	138
65	42	1.7	14	1940								
69	40	1.0	20	1870				VF 44_20	P71	BXN71MB4	124	
72	40	3.8	19	3400	W 63_19	S10	MXN10MB4	136	W 63_19	P71	BXN71MB4	138
76	36	1.6	18	2080				VF 49_18	P71	BXN71MB4	130	
79	33	0.9	35	1860								
91	32	2.0	10	1930								
98	29	1.0	14	1690				VF 44_14	P71	BXN71MB4	124	
98	29	2.2	14	1940				VF 49_14	P71	BXN71MB4	130	
117	24	2.0	24	1880								
137	22	1.3	10	1520				VF 44_10	P71	BXN71MB4	124	
137	22	2.7	10	1750				VF 49_10	P71	BXN71MB4	130	
138	21	1.4	20	1570								
153	19	2.3	18	1720								
196	16	1.9	7	1360				VF 44_7	P71	BXN71MB4	124	
196	16	3.5	7	1570				VF 49_7	P71	BXN71MB4	130	
275	11	2.0	10	1260								
393	8	2.8	7	1120								

0.55 kW

n ₂ min-1	M ₂ Nm	S	i	R _{n2} N	 			  				
					IE1	IE2		IE1		IE2		
0.29	4019	1.1	3200	19500				W/VF 86/185_3200	P80	BN80B6	174	
0.36	3946	1.1	2560	19500				W/VF 86/185_2560	P80	BN80B6	174	
0.43	2902	1.4	3200	19500				W/VF 86/185_3200	P80	BN80A4	BE80A4	174
0.47	3004	0.9	2944	16000				W/VF 86/150_2944	P80	BN80A4	BE80A4	166
0.50	3362	1.3	1840	19500				W/VF 86/185_1840	P80	BN80B6	174	
0.54	2805	1.5	2560	19500				W/VF 86/185_2560	P80	BN80A4	BE80A4	174
0.76	2642	1.0	1840	16000				W/VF 86/150_1840	P80	BN80A4	BE80A4	166
0.76	2364	1.8	1840	19500				W/VF 86/185_1840	P80	BN80A4	BE80A4	174

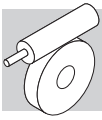

0.55 kW





n ₂ min ⁻¹	M ₂ Nm	S	i	R _{n2} N									
					IE1	IE2		IE1	IE2				
0.77	1905	0.9	1800	13800				W/VF 63/130_1800	P80	BN80A4	BE80A4	158	
0.87	2116	2.0	1600	19500				W/VF 86/185_1600	P80	BN80A4	BE80A4	174	
0.91	1838	1.0	1520	13800				W/VF 63/130_1520	P80	BN80A4	BE80A4	158	
1.0	1996	2.2	920	19500				W/VF 86/185_920	P80	BN80B6		174	
1.0	2190	1.2	1380	16000				W/VF 86/150_1380	P80	BN80A4	BE80A4	166	
1.2	1542	1.2	1200	13800				W/VF 63/130_1200	P80	BN80A4	BE80A4	158	
1.2	1542	2.7	1200	19500				W/VF 86/185_1200	P80	BN80A4	BE80A4	174	
1.3	1852	1.5	690	16000				W/VF 86/150_690	P80	BN80B6		166	
1.4	1342	1.3	960	13800				W/VF 63/130_960	P80	BN80A4	BE80A4	158	
1.5	1564	1.7	920	16000				W/VF 86/150_920	P80	BN80A4	BE80A4	166	
1.5	1460	2.9	920	19500				W/VF 86/185_920	P80	BN80A4	BE80A4	174	
1.5	1473	3.0	600	19500				W/VF 86/185_600	P80	BN80B6		174	
1.7	1300	3.2	800	19500				W/VF 86/185_800	P80	BN80A4	BE80A4	174	
1.7	1570	1.7	529	16000				W/VF 86/150_529	P80	BN80B6		166	
1.8	1120	1.6	760	13800				W/VF 63/130_760	P80	BN80A4	BE80A4	158	
2.0	1304	2.0	690	16000				W/VF 86/150_690	P80	BN80A4	BE80A4	166	
2.3	1028	1.0	400	8000				VF/W 49/110_400	P80	BN80B6		151	
2.3	907	2.0	600	13800				W/VF 63/130_600	P80	BN80A4	BE80A4	158	
2.6	837	1.2	540	8000				VF/W 49/110_540	P80	BN80A4	BE80A4	151	
2.6	1099	2.4	529	16000				W/VF 86/150_529	P80	BN80A4	BE80A4	166	
3.0	956	2.7	460	16000				W/VF 86/150_460	P80	BN80A4	BE80A4	166	
3.1	839	1.2	300	13800				VFR 130_300	P80	BN80B6		154	
3.1	805	1.3	300	8000				VF/W 49/110_300	P80	BN80B6		151	
3.5	680	1.5	400	8000				VF/W 49/110_400	P80	BN80A4	BE80A4	151	
3.5	665	2.7	400	13800				W/VF 63/130_400	P80	BN80A4	BE80A4	158	
3.8	740	1.6	240	13800				VFR 130_240	P80	BN80B6		154	
4.0	670	1.6	230	8000				VF/W 49/110_230	P80	BN80B6		151	
4.0	756	3.4	345	16000				W/VF 86/150_345	P80	BN80A4	BE80A4	166	
4.6	578	0.9	300	8000				WR 110_300	P80	BN80A4	BE80A4	150	
4.6	601	1.5	300	13800				VFR 130_300	P80	BN80A4	BE80A4	154	
4.6	544	1.8	300	8000				VF/W 49/110_300	P80	BN80A4	BE80A4	151	
4.8	625	1.1	192	8000				WR 110_192	P80	BN80B6		150	
5.0	529	3.4	280	13800				W/VF 63/130_280	P80	BN80A4	BE80A4	158	
5.8	508	1.1	240	8000				WR 110_240	P80	BN80A4	BE80A4	150	
5.8	517	2.2	240	13800				VFR 130_240	P80	BN80A4	BE80A4	154	
6.0	452	2.2	230	8000				VF/W 49/110_230	P80	BN80A4	BE80A4	151	
6.7	504	3.0	138	13800				VFR 130_138	P80	BN80B6		154	
7.2	435	1.4	192	8000				WR 110_192	P80	BN80A4	BE80A4	150	
7.2	443	2.7	192	13800				VFR 130_192	P80	BN80A4	BE80A4	154	
7.7	432	1.0	120	7000				WR 86_120	P80	BN80B6		146	
8.3	381	0.9	168	7000				WR 86_168	P80	BN80A4	BE80A4	146	
8.3	400	1.8	168	8000				WR 110_168	P80	BN80A4	BE80A4	150	
8.3	406	3.0	168	13800				VFR 130_168	P80	BN80A4	BE80A4	154	
9.2	325	1.5	100	8000	W 110_100 S2	M2SA6	148	W 110_100	P80	BN80B6		149	
10.1	329	1.2	138	7000				WR 86_138	P80	BN80A4	BE80A4	146	
10.1	344	2.1	138	8000				WR 110_138	P80	BN80A4	BE80A4	150	
10.2	344	1.1	90	6200				WR 75_90	P80	BN80B6		142	
11.5	269	1.0	80	7000	W 86_80 S2	M2SA6	144	W 86_80	P80	BN80B6		145	
11.6	286	1.1	120	6200				WR 75_120	P80	BN80A4	BE80A4	142	
11.6	299	1.3	120	7000				WR 86_120	P80	BN80A4	BE80A4	146	
11.6	308	2.6	120	8000				WR 110_120	P80	BN80A4	BE80A4	150	
12.3	300	1.1	75	6200				WR 75_75	P80	BN80B6		142	
13.3	288	1.4	69	7000				WR 86_69	P80	BN80B6		146	
13.3	295	2.5	69	8000				WR 110_69	P80	BN80B6		150	
13.8	225	1.0	100	7000	W 86_100 S1	M1LA4	ME2SA4	144	W 86_100	P80	BN80A4	BE80A4	145
15.4	235	1.4	90	6200				WR 75_90	P80	BN80A4	BE80A4	142	
15.4	228	1.9	90	7000				WR 86_90	P80	BN80A4	BE80A4	146	
15.4	238	3.5	90	8000				WR 110_90	P80	BN80A4	BE80A4	150	
16.4	211	1.5	56	7000	W 86_56 S2	M2SA6	144	W 86_56	P80	BN80B6		145	
17.3	180	1.0	80	6200	W 75_80 S1	M1LA4	ME2SA4	140	W 75_80	P80	BN80A4	BE80A4	141
17.3	195	1.3	80	7000	W 86_80 S1	M1LA4	ME2SA4	144	W 86_80	P80	BN80A4	BE80A4	145
18.5	207	1.4	75	6200				WR 75_75	P80	BN80A4	BE80A4	142	
20.1	196	1.9	69	7000				WR 86_69	P80	BN80A4	BE80A4	146	
20.1	201	3.2	69	8000				WR 110_69	P80	BN80A4	BE80A4	150	
20.4	162	1.0	45	4540	W 63_45 S2	M2SA6	136	W 63_45	P80	BN80B6		138	
21.6	166	1.7	64	7000	W 86_64 S1	M1LA4	ME2SA4	144	W 86_64	P80	BN80A4	BE80A4	145
23.0	148	1.3	60	6200	W 75_60 S1	M1LA4	ME2SA4	140	W 75_60	P80	BN80A4	BE80A4	141
23.0	162	2.2	40	7000	W 86_40 S2	M2SA6	144	W 86_40	P80	BN80B6		145	
23.2	175	1.7	60	6040				WR 75_60	P80	BN80A4	BE80A4	142	
23.2	175	2.2	60	7000				WR 86_60	P80	BN80A4	BE80A4	146	
24.2	143	1.2	38	4340	W 63_38 S2	M2SA6	136	W 63_38	P80	BN80B6		138	
24.6	149	2.0	56	7000	W 86_56 S1	M1LA4	ME2SA4	144	W 86_56	P80	BN80A4	BE80A4	145
27.6	129	1.7	50	5960	W 75_50 S1	M1LA4	ME2SA4	140	W 75_50	P80	BN80A4	BE80A4	141
30	128	2.7	46	7000	W 86_46 S1	M1LA4	ME2SA4	144	W 86_46	P80	BN80A4	BE80A4	145
31	115	1.3	45	4140	W 63_45 S1	M1LA4	ME2SA4	136	W 63_45	P80	BN80A4	BE80A4	138
31	136	2.2	45	5580				WR 75_45	P80	BN80A4	BE80A4	142	



0.55 kW

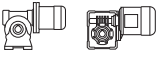





n ₂ min ⁻¹	M ₂ Nm	S	i	R _{n2} N	 IE1 IE2					 IE1 IE2				
31	133	2.9	45	7000						WR 86_45	P80	BN80A4	BE80A4	146
35	110	2.3	40	5610	W 75_40	S1	M1LA4	ME2SA4	140	W 75_40	P80	BN80A4	BE80A4	141
35	114	2.9	40	7000	W 86_40	S1	M1LA4	ME2SA4	144	W 86_40	P80	BN80A4	BE80A4	145
36	101	1.5	38	3950	W 63_38	S1	M1LA4	ME2SA4	136	W 63_38	P80	BN80A4	BE80A4	138
40	105	3.3	23	7000	W 86_23	S2	M2SA6		144	W 86_23	P80	BN80B6		145
46	84	1.9	30	3700	W 63_30	S1	M1LA4	ME2SA4	136	W 63_30	P80	BN80A4	BE80A4	138
46	88	3.1	30	5150	W 75_30	S1	M1LA4	ME2SA4	140	W 75_30	P80	BN80A4	BE80A4	141
46	95	2.9	30	4950						WR 75_30	P80	BN80A4	BE80A4	142
49	76	1.0	28	2170						VF 49_28	P80	BN80A4	BE80A4	130
55	76	3.3	25	4880	W 75_25	S1	M1LA4	ME2SA4	140	W 75_25	P80	BN80A4	BE80A4	141
58	69	0.9	24	2080						VF 49_24	P80	BN80A4	BE80A4	130
58	71	2.2	24	3480	W 63_24	S1	M1LA4	ME2SA4	136	W 63_24	P80	BN80A4	BE80A4	138
66	62	1.1	14	1960						VF 49_14	P80	BN80B6		130
73	59	2.6	19	3260	W 63_19	S1	M1LA4	ME2SA4	136	W 63_19	P80	BN80A4	BE80A4	138
77	53	1.1	18	1930						VF 49_18	P80	BN80A4	BE80A4	130
92	47	1.4	10	1800						VF 49_10	P80	BN80B6		130
92	47	3.2	15	3050	W 63_15	S1	M1LA4	ME2SA4	136	W 63_15	P80	BN80A4	BE80A4	138
99	43	1.5	14	1810						VF 49_14	P80	BN80A4	BE80A4	130
115	39	3.6	12	2850	W 63_12	S1	M1LA4	ME2SA4	136	W 63_12	P80	BN80A4	BE80A4	138
117	35	1.3	24	1800						VF 49_24	P71	BN71B2		130
131	35	3.7	7	2700	W 63_7	S2	M2SA6		136	W 63_7	P80	BN80B6		138
138	32	1.8	10	1650						VF 49_10	P80	BN80A4	BE80A4	130
141	30	1.0	20	1490						VF 44_20	P71	BN71B2		124
156	28	1.6	18	1650						VF 49_18	P71	BN71B2		130
197	23	2.4	7	1480						VF 49_7	P80	BN80A4	BE80A4	130
281	16	1.4	10	1210						VF 44_10	P71	BN71B2		124
281	16	2.7	10	1390						VF 49_10	P71	BN71B2		130
401	12	1.9	7	1080						VF 44_7	P71	BN71B2		124

0.55 kW

n ₂ min ⁻¹	M ₂ Nm	S	i	R _{n2} N	 IE3					 IE3				
0.29	4019	1.1	3200	19500										
0.36	3946	1.1	2560	19500										
0.43	2902	1.4	3200	19500	W/VF 86/185_3200	S20	MXN20MA4		174	W/VF 86/185_3200	P80	BXN80MA4		174
0.47	3004	0.9	2944	16000	W/VF 86/150_2944	S20	MXN20MA4		166	W/VF 86/150_2944	P80	BXN80MA4		166
0.50	3362	1.3	1840	19500										
0.54	2805	1.5	2560	19500	W/VF 86/185_2560	S20	MXN20MA4		174	W/VF 86/185_2560	P80	BXN80MA4		174
0.76	2642	1.0	1840	16000	W/VF 86/150_1840	S20	MXN20MA4		166	W/VF 86/150_1840	P80	BXN80MA4		166
0.76	2364	1.8	1840	19500	W/VF 86/185_1840	S20	MXN20MA4		174	W/VF 86/185_1840	P80	BXN80MA4		174
0.77	1905	0.9	1800	13800	W/VF 63/130_1800	S20	MXN20MA4		158	W/VF 63/130_1800	P80	BXN80MA4		158
0.87	2116	2.0	1600	19500	W/VF 86/185_1600	S20	MXN20MA4		174	W/VF 86/185_1600	P80	BXN80MA4		174
0.91	1838	1.0	1520	13800	W/VF 63/130_1520	S20	MXN20MA4		158	W/VF 63/130_1520	P80	BXN80MA4		158
1.0	1996	2.2	920	19500										
1.0	2190	1.2	1380	16000	W/VF 86/150_1380	S20	MXN20MA4		166	W/VF 86/150_1380	P80	BXN80MA4		166
1.2	1542	1.2	1200	13800	W/VF 63/130_1200	S20	MXN20MA4		158	W/VF 63/130_1200	P80	BXN80MA4		158
1.2	1542	2.7	1200	19500	W/VF 86/185_1200	S20	MXN20MA4		174	W/VF 86/185_1200	P80	BXN80MA4		174
1.3	1852	1.5	690	16000										
1.4	1342	1.3	960	13800	W/VF 63/130_960	S20	MXN20MA4		158	W/VF 63/130_960	P80	BXN80MA4		158
1.5	1564	1.7	920	16000	W/VF 86/150_920	S20	MXN20MA4		166	W/VF 86/150_920	P80	BXN80MA4		166
1.5	1460	2.9	920	19500	W/VF 86/185_920	S20	MXN20MA4		174	W/VF 86/185_920	P80	BXN80MA4		174
1.5	1473	3.0	600	19500										
1.7	1300	3.2	800	19500	W/VF 86/185_800	S20	MXN20MA4		174	W/VF 86/185_800	P80	BXN80MA4		174
1.7	1570	1.7	529	16000										
1.8	1120	1.6	760	13800	W/VF 63/130_760	S20	MXN20MA4		158	W/VF 63/130_760	P80	BXN80MA4		158
2.0	1304	2.0	690	16000	W/VF 86/150_690	S20	MXN20MA4		166	W/VF 86/150_690	P80	BXN80MA4		166
2.3	1028	1.0	400	8000										
2.3	907	2.0	600	13800	W/VF 63/130_600	S20	MXN20MA4		158	W/VF 63/130_600	P80	BXN80MA4		158
2.6	837	1.2	540	8000						VF/W 49/110_540	P80	BXN80MA4		151
2.6	1099	2.4	529	16000	W/VF 86/150_529	S20	MXN20MA4		166	W/VF 86/150_529	P80	BXN80MA4		166
3.0	956	2.7	460	16000	W/VF 86/150_460	S20	MXN20MA4		166	W/VF 86/150_460	P80	BXN80MA4		166
3.1	839	1.2	300	13800										
3.1	805	1.3	300	8000										
3.5	680	1.5	400	8000										
3.5	665	2.7	400	13800	W/VF 63/130_400	S20	MXN20MA4		158	VF/W 49/110_400	P80	BXN80MA4		151
3.8	740	1.6	240	13800						W/VF 63/130_400	P80	BXN80MA4		158
4.0	670	1.6	230	8000										
4.0	756	3.4	345	16000	W/VF 86/150_345	S20	MXN20MA4		166	W/VF 86/150_345	P80	BXN80MA4		166
4.6	578	0.9	300	8000						WR 110_300	P80	BXN80MA4		150
4.6	601	1.5	300	13800						VFR 130_300	P80	BXN80MA4		154







0.55 kW

n ₂ min ⁻¹	M ₂ Nm	S	i	R _{n2} N	  IE3			   IEC				
					W/VF	S2	MXN20MA4	158	W/VF	P80		BXN80MA4
4.6	544	1.8	300	8000					VF/W 49/110_300	P80	BXN80MA4	151
4.8	625	1.1	192	8000								
5.0	529	3.4	280	13800	W/VF 63/130_280	S20	MXN20MA4	158	W/VF 63/130_280	P80	BXN80MA4	158
5.8	508	1.1	240	8000					WR 110_240	P80	BXN80MA4	150
5.8	517	2.2	240	13800					VFR 130_240	P80	BXN80MA4	154
6.0	452	2.2	230	8000					VF/W 49/110_230	P80	BXN80MA4	151
6.7	504	3.0	138	13800								
7.2	435	1.4	192	8000					WR 110_192	P80	BXN80MA4	150
7.2	443	2.7	192	13800					VFR 130_192	P80	BXN80MA4	154
7.7	432	1.0	120	7000								
8.3	381	0.9	168	7000					WR 86_168	P80	BXN80MA4	146
8.3	400	1.8	168	8000					WR 110_168	P80	BXN80MA4	150
8.3	406	3.0	168	13800					VFR 130_168	P80	BXN80MA4	154
9.2	325	1.5	100	8000								
10.1	329	1.2	138	7000					WR 86_138	P80	BXN80MA4	146
10.1	344	2.1	138	8000					WR 110_138	P80	BXN80MA4	150
10.2	344	1.1	90	6200								
11.5	269	1.0	80	7000								
11.6	286	1.1	120	6200					WR 75_120	P80	BXN80MA4	142
11.6	299	1.3	120	7000					WR 86_120	P80	BXN80MA4	146
11.6	308	2.6	120	8000					WR 110_120	P80	BXN80MA4	150
12.3	300	1.1	75	6200								
13.3	288	1.4	69	7000								
13.3	295	2.5	69	8000								
13.8	225	1.0	100	7000	W 86_100	S20	MXN20MA4	144	W 86_100	P80	BXN80MA4	145
15.4	235	1.4	90	6200					WR 75_90	P80	BXN80MA4	142
15.4	228	1.9	90	7000					WR 86_90	P80	BXN80MA4	146
15.4	238	3.5	90	8000					WR 110_90	P80	BXN80MA4	150
16.4	211	1.5	56	7000								
17.3	180	1.0	80	6200	W 75_80	S20	MXN20MA4	140	W 75_80	P80	BXN80MA4	141
17.3	195	1.3	80	7000	W 86_80	S20	MXN20MA4	144	W 86_80	P80	BXN80MA4	145
18.5	207	1.4	75	6200					WR 75_75	P80	BXN80MA4	142
20.1	196	1.9	69	7000					WR 86_69	P80	BXN80MA4	146
20.1	201	3.2	69	8000					WR 110_69	P80	BXN80MA4	150
20.4	162	1.0	45	4540								
21.6	166	1.7	64	7000	W 86_64	S20	MXN20MA4	144	W 86_64	P80	BXN80MA4	145
23.0	148	1.3	60	6200	W 75_60	S20	MXN20MA4	140	W 75_60	P80	BXN80MA4	141
23.0	162	2.2	40	7000								
23.2	175	1.7	60	6040					WR 75_60	P80	BXN80MA4	142
23.2	175	2.2	60	7000					WR 86_60	P80	BXN80MA4	146
24.2	143	1.2	38	4340								
24.6	149	2.0	56	7000	W 86_56	S20	MXN20MA4	144	W 86_56	P80	BXN80MA4	145
27.6	129	1.7	50	5960	W 75_50	S20	MXN20MA4	140	W 75_50	P80	BXN80MA4	141
30	128	2.7	46	7000	W 86_46	S20	MXN20MA4	144	W 86_46	P80	BXN80MA4	145
31	115	1.3	45	4140	W 63_45	S20	MXN20MA4	136	W 63_45	P80	BXN80MA4	138
31	136	2.2	45	5580					WR 75_45	P80	BXN80MA4	142
31	133	2.9	45	7000					WR 86_45	P80	BXN80MA4	146
35	110	2.3	40	5610	W 75_40	S20	MXN20MA4	140	W 75_40	P80	BXN80MA4	141
35	114	2.9	40	7000	W 86_40	S20	MXN20MA4	144	W 86_40	P80	BXN80MA4	145
36	101	1.5	38	3950	W 63_38	S20	MXN20MA4	136	W 63_38	P80	BXN80MA4	138
40	105	3.3	23	7000								
46	84	1.9	30	3700	W 63_30	S20	MXN20MA4	136	W 63_30	P80	BXN80MA4	138
46	88	3.1	30	5150	W 75_30	S20	MXN20MA4	140	W 75_30	P80	BXN80MA4	141
46	95	2.9	30	4950					WR 75_30	P80	BXN80MA4	142
49	76	1.0	28	2170					VF 49_28	P80	BXN80MA4	130
55	76	3.3	25	4880	W 75_25	S20	MXN20MA4	140	W 75_25	P80	BXN80MA4	141
58	69	0.9	24	2080					VF 49_24	P80	BXN80MA4	130
58	71	2.2	24	3480	W 63_24	S20	MXN20MA4	136	W 63_24	P80	BXN80MA4	138
66	62	1.1	14	1960								
73	59	2.6	19	3260	W 63_19	S20	MXN20MA4	136	W 63_19	P80	BXN80MA4	138
77	53	1.1	18	1930					VF 49_18	P80	BXN80MA4	130
92	47	1.4	10	1800								
92	47	3.2	15	3050	W 63_15	S20	MXN20MA4	136	W 63_15	P80	BXN80MA4	138
99	43	1.5	14	1810					VF 49_14	P80	BXN80MA4	130
115	39	3.6	12	2850	W 63_12	S20	MXN20MA4	136	W 63_12	P80	BXN80MA4	138
117	35	1.3	24	1800								
131	35	3.7	7	2700								
138	32	1.8	10	1650					VF 49_10	P80	BXN80MA4	130
141	30	1.0	20	1490								
156	28	1.6	18	1650								
197	23	2.4	7	1480					VF 49_7	P80	BXN80MA4	130
281	16	1.4	10	1210								
281	16	2.7	10	1390								
401	12	1.9	7	1080								

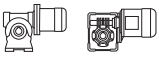

0.75 kW

n ₂ min ⁻¹	M ₂ Nm	S	i	R _{n2} N	 IE2 IE3			 IEC IE2 IE3						
0.29	4867	1.3	3200	34500				VF/NF 130/210_3200	P90	BE90S6		180		
0.29	4623	1.9	3200	52000				VF/NF 130/250_3200	P90	BE90S6		186		
0.37	4672	1.4	2560	34500				VF/NF 130/210_2560	P90	BE90S6		180		
0.37	4478	2.0	2560	52000				VF/NF 130/250_2560	P90	BE90S6		186		
0.45	3852	1.1	3200	19500				W/NF 86/185_3200	P80	BE80B4	BX80B4	174		
0.51	4478	1.0	1840	19500				W/NF 86/185_1840	P90	BE90S6		174		
0.51	3918	1.6	1840	34500				VF/NF 130/210_1840	P90	BE90S6		180		
0.51	4058	2.3	1840	52000				VF/NF 130/250_1840	P90	BE90S6		186		
0.56	3724	1.1	2560	19500				W/NF 86/185_2560	P80	BE80B4	BX80B4	174		
0.78	3138	1.3	1840	19500				W/NF 86/185_1840	P80	BE80B4	BX80B4	174		
0.90	2809	1.5	1600	19500				W/NF 86/185_1600	P80	BE80B4	BX80B4	174		
1.0	2659	1.6	920	19500				W/NF 86/185_920	P90	BE90S6		174		
1.2	2046	0.9	1200	13800				W/NF 63/130_1200	P80	BE80B4	BX80B4	158		
1.2	2046	2.0	1200	19500				W/NF 86/185_1200	P80	BE80B4	BX80B4	174		
1.4	2466	1.1	690	16000				W/NF 86/150_690	P90	BE90S6		166		
1.5	1781	1.0	960	13800				W/NF 63/130_960	P80	BE80B4	BX80B4	158		
1.5	2076	1.2	920	16000				W/NF 86/150_920	P80	BE80B4	BX80B4	166		
1.5	1938	2.1	920	19500				W/NF 86/185_920	P80	BE80B4	BX80B4	174		
1.8	2092	1.3	529	16000				W/NF 86/150_529	P90	BE90S6		166		
1.8	1725	2.4	800	19500				W/NF 86/185_800	P80	BE80B4	BX80B4	174		
1.8	1486	1.2	760	13800				W/NF 63/130_760	P80	BE80B4	BX80B4	158		
2.0	1730	1.5	690	16000				W/NF 86/150_690	P80	BE80B4	BX80B4	166		
2.3	1204	1.5	600	13800				W/NF 63/130_600	P80	BE80B4	BX80B4	158		
2.3	1354	3.1	600	19500				W/NF 86/185_600	P80	BE80B4	BX80B4	174		
2.7	1460	1.7	529	16000				W/NF 86/150_529	P80	BE80B4	BX80B4	166		
3.1	1269	2.0	460	16000				W/NF 86/150_460	P80	BE80B4	BX80B4	166		
3.1	1140	1.2	300	16000				VFR 150_300	P90	BE90S6		162		
3.1	1141	2.1	300	19500				VFR 185_300	P90	BE90S6		170		
3.6	903	1.1	400	8000				VF/W 49/110_400	P80	BE80B4	BX80B4	151		
3.6	882	2.0	400	13800				W/NF 63/130_400	P80	BE80B4	BX80B4	158		
3.9	986	1.2	240	13800				VFR 130_240	P90	BE90S6		154		
3.9	986	1.7	240	16000				VFR 150_240	P90	BE90S6		162		
3.9	986	2.9	240	19500				VFR 185_240	P90	BE90S6		170		
4.2	1004	2.6	345	16000				W/NF 86/150_345	P80	BE80B4	BX80B4	166		
4.8	797	1.1	300	13800				VFR 130_300	P80	BE80B4	BX80B4	154		
4.8	723	1.4	300	8000				VF/W 49/110_300	P80	BE80B4	BX80B4	151		
4.8	873	3.0	300	16000				W/NF 86/150_300	P80	BE80B4	BX80B4	166		
4.9	862	2.3	192	16000				VFR 150_192	P90	BE90S6		162		
5.1	702	2.6	280	13800				W/NF 63/130_280	P80	BE80B4	BX80B4	158		
5.6	767	1.0	168	8000				WR 110_168	P90	BE90S6		150		
5.6	661	1.2	168	16000				VFR 150_168	P90	BE90S6		162		
5.9	394	1.9	240	13800				VFR 130_240	P80	BE80B4	BX80B4	154		
6.2	267	1.3	230	8000				VF/W 49/110_230	P80	BE80B4	BX80B4	151		
6.8	661	1.2	138	8000				WR 110_138	P90	BE90S6		150		
6.8	672	2.3	138	13800				VFR 130_138	P90	BE90S6		154		
7.4	577	1.1	192	8000				WR 110_192	P80	BE80B4	BX80B4	150		
7.5	587	2.0	192	13800				VFR 130_192	P80	BE80B4	BX80B4	154		
8.5	530	1.3	168	8000				WR 110_168	P80	BE80B4	BX80B4	150		
8.5	539	2.2	168	13800				VFR 130_168	P80	BE80B4	BX80B4	154		
9.4	434	1.1	100	8000	W110_100	S3	ME3SA6	148	W 110_100	P90	BE90S6		149	
9.4	448	1.7	100	13200				VF 130_100	P90	BE90S6		152		
10.4	436	0.9	138	7000				WR 86_138	P80	BE80B4	BX80B4	146		
10.4	455	1.6	138	8000				WR 110_138	P80	BE80B4	BX80B4	150		
10.3	464	3.0	138	13800				VFR 130_138	P80	BE80B4	BX80B4	154		
11.8	372	1.4	80	8000	W110_80	S3	ME3SA6	148	W 110_80	P90	BE90S6		149	
11.8	390	2.5	80	13200				VF 130_80	P90	BE90S6		152		
12.0	397	1.0	120	7000				WR 86_120	P80	BE80B4	BX80B4	146		
12.0	409	1.9	120	8000				WR 110_120	P80	BE80B4	BX80B4	150		
12.0	403	3.5	120	13800				VFR 130_120	P80	BE80B4	BX80B4	154		
13.6	394	1.9	69	8000				WR 110_69	P90	BE90S6		150		
14.3	311	1.5	100	8000	W110_100	S2	ME2SB4	MX2SB4	148	W 110_100	P80	BE80B4	BX80B4	149
14.7	307	1.0	64	7000	W86_64	S3	ME3SA6	144	W 86_64	P90	BE90S6		145	
14.7	331	3.2	64	13200				VF 130_64	P90	BE90S6		152		
15.9	312	1.0	90	6200				WR 75_90	P80	BE80B4	BX80B4	142		
15.9	302	1.5	90	7000				WR 86_90	P80	BE80B4	BX80B4	146		
15.9	316	2.6	90	8000				WR 110_90	P80	BE80B4	BX80B4	150		
16.8	281	1.2	56	7000	W86_56	S3	ME3SA6	144	W 86_56	P90	BE90S6		145	
16.8	289	2.2	56	8000	W110_56	S3	ME3SA6	148	W 110_56	P90	BE90S6		149	
17.9	257	1.0	80	7000	W86_80	S2	ME2SB4	MX2SB4	144	W 86_80	P80	BE80B4	BX80B4	145
17.9	265	1.8	80	8000	W110_80	S2	ME2SB4	MX2SB4	148	W 110_80	P80	BE80B4	BX80B4	149
18.8	239	1.0	50	6200	W75_50	S3	ME3SA6	140	W 75_50	P90	BE90S6	BE90S6	141	
19.1	275	1.1	75	5980				WR 75_75	P80	BE80B4	BX80B4	142		



0.75 kW





n ₂ min ⁻¹	M ₂ Nm	S	i	R _{n2} N										
					IE2	IE3			IE2	IE3				
20.7	260	1.5	69	7000				WR 86_69	P80	BE80B4	BX80B4	146		
20.7	267	2.4	69	8000				WR 110_69	P80	BE80B4	BX80B4	150		
20.9	267	1.3	45	6010				WR 75_45	P90	BE90S6		142		
22.4	219	1.3	64	7000	W86_64	S2	ME2SB4	MX2SB4	144	W 86_64	P80	BE80B4	BX80B4	145
22.4	225	2.4	64	8000	W110_64	S2	ME2SB4	MX2SB4	148	W 110_64	P80	BE80B4	BX80B4	149
23.5	207	1.3	40	5930	W75_40	S3	ME3SA6		140	W 75_40	P90	BE90S6		141
23.8	196	1.0	60	5960	W75_60	S2	ME2SB4	MX2SB4	140	W 75_60	P80	BE80B4	BX80B4	141
23.8	231	1.3	60	5640						WR 75_60	P80	BE80B4	BX80B4	142
23.8	231	1.6	60	7000						WR 86_60	P80	BE80B4	BX80B4	146
23.8	238	2.8	60	8000						WR 110_60	P80	BE80B4	BX80B4	150
25.5	197	1.5	56	7000	W86_56	S2	ME2SB4	MX2SB4	144	W 86_56	P80	BE80B4	BX80B4	145
25.5	202	3.0	56	8000	W110_56	S2	ME2SB4	MX2SB4	148	W 110_56	P80	BE80B4	BX80B4	149
28.6	171	1.3	50	5670	W75_50	S2	ME2SB4	MX2SB4	140	W 75_50	P80	BE80B4	BX80B4	141
30.6	169	2.0	46	7000	W86_46	S2	ME2SB4	MX2SB4	144	W 86_46	P80	BE80B4	BX80B4	145
30.6	171	3.5	46	8000	W110_46	S2	ME2SB4	MX2SB4	148	W 110_46	P80	BE80B4	BX80B4	149
32	151	1.0	45	3860	W63_45	S2	ME2SB4	MX2SB4	136	W 63_45	P80	BE80B4	BX80B4	138
32	180	1.6	45	5250						WR 75_45	P80	BE80B4	BX80B4	142
32	176	2.2	45	7000						WR 86_45	P80	BE80B4	BX80B4	146
36	144	1.8	40	5370	W75_40	S2	ME2SB4	MX2SB4	140	W 75_40	P80	BE80B4	BX80B4	141
36	150	2.2	40	7000	W86_40	S2	ME2SB4	MX2SB4	144	W 86_40	P80	BE80B4	BX80B4	145
38	133	1.2	38	3700	W63_38	S2	ME2SB4	MX2SB4	136	W 63_38	P80	BE80B4	BX80B4	138
41	140	2.5	23	7000	W86_23	S3	ME3SA6		144	W 86_23	P90	BE90S6		145
48	112	1.4	30	3490	W63_30	S2	ME2SB4	MX2SB4	136	W 63_30	P80	BE80B4	BX80B4	138
48	126	2.2	30	4680						WR 75_30	P80	BE80B4	BX80B4	142
48	116	2.3	30	4950	W75_30	S2	ME2SB4	MX2SB4	140	W 75_30	P80	BE80B4	BX80B4	141
48	115	3.3	30	7000	W86_30	S2	ME2SB4	MX2SB4	144	W 86_30	P80	BE80B4	BX80B4	145
57	100	2.5	25	4700	W75_25	S2	ME2SB4	MX2SB4	140	W 75_25	P80	BE80B4	BX80B4	141
60	94	1.7	24	3290	W63_24	S2	ME2SB4	MX2SB4	136	W 63_24	P80	BE80B4	BX80B4	138
62	94	3.4	23	7000	W86_23	S2	ME2SB4	MX2SB4	144	W 86_23	P80	BE80B4	BX80B4	145
72	83	3.0	20	4400	W75_20	S2	ME2SB4	MX2SB4	140	W 75_20	P80	BE80B4	BX80B4	141
75	77	1.9	19	3100	W63_19	S2	ME2SB4	MX2SB4	136	W 63_19	P80	BE80B4	BX80B4	138
95	63	2.4	15	2910	W63_15	S2	ME2SB4	MX2SB4	136	W 63_15	P80	BE80B4	BX80B4	138
102	57	1.1	14	1690						VF 49_14	P80	BE80B4	BX80B4	130
119	47	1.0	24	1710						VF 49_24	P80	BE80A2		130
119	51	2.7	12	2740	W63_12	S2	ME2SB4	MX2SB4	136	W 63_12	P80	BE80B4	BX80B4	138
134	46	2.8	7	2590						W 63_7	P90	BE90S6		138
143	42	1.4	10	1540						VF 49_10	P80	BE80B4	BX80B4	130
143	43	3.3	10	2600	W63_10	S2	ME2SB4	MX2SB4	136	W 63_10	P80	BE80B4	BX80B4	138
190	32	3.9	15	2440	W 63_15	S2	ME2SA2		136	W 63_15	P80	BE80A2		138
204	30	1.8	7	1400						VF 49_7	P80	BE80B4	BX80B4	130
204	31	3.9	7	2340	W63_7	S2	ME2SB4	MX2SB4	136	W 63_7	P80	BE80B4	BX80B4	138
285	21	2.1	10	1340						VF 49_10	P80	BE80A2		130
407	15.5	2.7	7	1200						VF 49_7	P80	BE80A2		130

0.75 kW

n ₂ min ⁻¹	M ₂ Nm	S	i	R _{n2} N									
					IE3				IE3				
0.29	4867	1.3	3200	34500									
0.29	4623	1.9	3200	52000									
0.37	4672	1.4	2560	34500									
0.37	4478	2.0	2560	52000									
0.45	3852	1.1	3200	19500	W /VF 86/185_3200	S20	MXN20MB4	174	W /VF 86/185_3200	P80	BXN80MB4	174	
0.51	4478	1.0	1840	19500									
0.51	3918	1.6	1840	34500									
0.51	4058	2.3	1840	52000									
0.56	3724	1.1	2560	19500	W /VF 86/185_2560	S20	MXN20MB4	174	W /VF 86/185_2560	P80	BXN80MB4	174	
0.78	3138	1.3	1840	19500	W /VF 86/185_1840	S20	MXN20MB4	174	W /VF 86/185_1840	P80	BXN80MB4	174	
0.90	2809	1.5	1600	19500	W /VF 86/185_1600	S20	MXN20MB4	174	W /VF 86/185_1600	P80	BXN80MB4	174	
1.0	2659	1.6	920	19500									
1.2	2046	0.9	1200	13800	W /VF 63/130_1200	S20	MXN20MB4	158	W /VF 63/130_1200	P80	BXN80MB4	158	
1.2	2046	2.0	1200	19500	W /VF 86/185_1200	S20	MXN20MB4	174	W /VF 86/185_1200	P80	BXN80MB4	174	
1.4	2466	1.1	690	16000									
1.5	1781	1.0	960	13800	W /VF 63/130_960	S20	MXN20MB4	158	W /VF 63/130_960	P80	BXN80MB4	158	
1.5	2076	1.2	920	16000	W /VF 86/150_920	S20	MXN20MB4	166	W /VF 86/150_920	P80	BXN80MB4	166	
1.5	1938	2.1	920	19500	W /VF 86/185_920	S20	MXN20MB4	174	W /VF 86/185_920	P80	BXN80MB4	174	
1.8	2092	1.3	529	16000									







0.75 kW



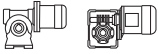

n ₂ min ⁻¹	M ₂ Nm	S	i	R _{n2} N	  IE3			  IEC				
					W / VF	S20	MXN20MB4	W / VF	P80	BXN80MB4		
1.8	1725	2.4	800	19500	W / VF 86/185_800	S20	MXN20MB4	174	W / VF 86/185_800	P80	BXN80MB4	174
1.8	1486	1.2	760	13800	W / VF 63/130_760	S20	MXN20MB4	158	W / VF 63/130_760	P80	BXN80MB4	158
2.0	1730	1.5	690	16000	W / VF 86/150_690	S20	MXN20MB4	166	W / VF 86/150_690	P80	BXN80MB4	166
2.3	1204	1.5	600	13800	W / VF 63/130_600	S20	MXN20MB4	158	W / VF 63/130_600	P80	BXN80MB4	158
2.3	1354	3.1	600	19500	W / VF 86/185_600	S20	MXN20MB4	174	W / VF 86/185_600	P80	BXN80MB4	174
2.7	1460	1.7	529	16000	W / VF 86/150_529	S20	MXN20MB4	166	W / VF 86/150_529	P80	BXN80MB4	166
3.1	1269	2.0	460	16000	W / VF 86/150_460	S20	MXN20MB4	166	W / VF 86/150_460	P80	BXN80MB4	166
3.1	1140	1.2	300	16000								
3.1	1141	2.1	300	19500								
3.6	903	1.1	400	8000					VF/W 49/110_400	P80	BXN80MB4	151
3.6	882	2.0	400	13800	W / VF 63/130_400	S20	MXN20MB4	158	W / VF 63/130_400	P80	BXN80MB4	158
3.9	986	1.2	240	13800								
3.9	986	1.7	240	16000								
3.9	986	2.9	240	19500								
4.2	1004	2.6	345	16000	W / VF 86/150_345	S20	MXN20MB4	166	W / VF 86/150_345	P80	BXN80MB4	166
4.8	797	1.1	300	13800					VFR 130_300	P80	BXN80MB4	154
4.8	723	1.4	300	8000					VF/W 49/110_300	P80	BXN80MB4	151
4.8	873	3.0	300	16000	W / VF 86/150_300	S20	MXN20MB4	166	W / VF 86/150_300	P80	BXN80MB4	166
4.9	862	2.3	192	16000								
5.1	702	2.6	280	13800	W / VF 63/130_280	S20	MXN20MB4	158	W / VF 63/130_280	P80	BXN80MB4	158
5.6	767	1.0	168	8000								
5.6	661	1.2	168	16000					VFR 130_240	P80	BXN80MB4	154
5.9	394	1.9	240	13800					VF/W 49/110_230	P80	BXN80MB4	151
6.2	267	1.3	230	8000								
6.8	661	1.2	138	8000								
6.8	672	2.3	138	13800								
7.4	577	1.1	192	8000					WR 110_192	P80	BXN80MB4	150
7.5	587	2.0	192	13800					VFR 130_192	P80	BXN80MB4	154
8.5	530	1.3	168	8000					WR 110_168	P80	BXN80MB4	150
8.5	539	2.2	168	13800					VFR 130_168	P80	BXN80MB4	154
9.4	434	1.1	100	8000								
9.4	448	1.7	100	13200								
10.4	436	0.9	138	7000					WR 86_138	P80	BXN80MB4	146
10.4	455	1.6	138	8000					WR 110_138	P80	BXN80MB4	150
10.3	464	3.0	138	13800					VFR 130_138	P80	BXN80MB4	154
11.8	372	1.4	80	8000								
11.8	390	2.5	80	13200								
12.0	397	1.0	120	7000					WR 86_120	P80	BXN80MB4	146
12.0	409	1.9	120	8000					WR 110_120	P80	BXN80MB4	150
12.0	403	3.5	120	13800					VFR 130_120	P80	BXN80MB4	154
13.6	394	1.9	69	8000								
14.3	311	1.5	100	8000					W 110_100	P80	BXN80MB4	149
14.7	307	1.0	64	7000								
14.7	331	3.2	64	13200								
15.9	312	1.0	90	6200					WR 75_90	P80	BXN80MB4	142
15.9	302	1.5	90	7000					WR 86_90	P80	BXN80MB4	146
15.9	316	2.6	90	8000					WR 110_90	P80	BXN80MB4	150
16.8	281	1.2	56	7000								
16.8	289	2.2	56	8000								
17.9	257	1.0	80	7000	W86_80	S20	MXN20MB4	144	W 86_80	P80	BXN80MB4	145
17.9	265	1.8	80	8000					W 110_80	P80	BXN80MB4	149
18.8	239	1.0	50	6200								
19.1	275	1.1	75	5980					WR 75_75	P80	BXN80MB4	142
20.7	260	1.5	69	7000					WR 86_69	P80	BXN80MB4	146
20.7	267	2.4	69	8000					WR 110_69	P80	BXN80MB4	150
20.9	267	1.3	45	6010								
22.4	219	1.3	64	7000	W86_64	S20	MXN20MB4	144	W 86_64	P80	BXN80MB4	145
22.4	225	2.4	64	8000					W 110_64	P80	BXN80MB4	149
23.5	207	1.3	40	5930								
23.8	196	1.0	60	5960	W75_60	S20	MXN20MB4	140	W 75_60	P80	BXN80MB4	141
23.8	231	1.3	60	5640					WR 75_60	P80	BXN80MB4	142
23.8	231	1.6	60	7000					WR 86_60	P80	BXN80MB4	146
23.8	238	2.8	60	8000					WR 110_60	P80	BXN80MB4	150
25.5	197	1.5	56	7000	W86_56	S20	MXN20MB4	144	W 86_56	P80	BXN80MB4	145
25.5	202	3.0	56	8000					W 110_56	P80	BXN80MB4	149
28.6	171	1.3	50	5670	W75_50	S20	MXN20MB4	140	W 75_50	P80	BXN80MB4	141
30.6	169	2.0	46	7000	W86_46	S20	MXN20MB4	144	W 86_46	P80	BXN80MB4	145
30.6	171	3.5	46	8000					W 110_46	P80	BXN80MB4	149
32	151	1.0	45	3860	W63_45	S20	MXN20MB4	136	W 63_45	P80	BXN80MB4	138
32	180	1.6	45	5250					WR 75_45	P80	BXN80MB4	142
32	176	2.2	45	7000					WR 86_45	P80	BXN80MB4	146
36	144	1.8	40	5370	W75_40	S20	MXN20MB4	140	W 75_40	P80	BXN80MB4	141



0.75 kW

n ₂ min ⁻¹	M ₂ Nm	S	i	R _{n2} N	 IE3				 IEC			
					W	S2	MXN20MB4		W	P80	BXN80MB4	
36	150	2.2	40	7000	W86_40	S20	MXN20MB4	144	W 86_40	P80	BXN80MB4	145
38	133	1.2	38	3700	W63_38	S20	MXN20MB4	136	W 63_38	P80	BXN80MB4	138
41	140	2.5	23	7000								
48	112	1.4	30	3490	W63_30	S20	MXN20MB4	136	W 63_30	P80	BXN80MB4	138
48	126	2.2	30	4680					WR 75_30	P80	BXN80MB4	142
48	116	2.3	30	4950	W75_30	S20	MXN20MB4	140	W 75_30	P80	BXN80MB4	141
48	115	3.3	30	7000	W86_30	S20	MXN20MB4	144	W 86_30	P80	BXN80MB4	145
57	100	2.5	25	4700	W75_25	S20	MXN20MB4	140	W 75_25	P80	BXN80MB4	141
60	94	1.7	24	3290	W63_24	S20	MXN20MB4	136	W 63_24	P80	BXN80MB4	138
62	94	3.4	23	7000	W86_23	S20	MXN20MB4	144	W 86_23	P80	BXN80MB4	145
72	83	3.0	20	4400	W75_20	S20	MXN20MB4	140	W 75_20	P80	BXN80MB4	141
75	77	1.9	19	3100	W63_19	S20	MXN20MB4	136	W 63_19	P80	BXN80MB4	138
95	63	2.4	15	2910	W63_15	S20	MXN20MB4	136	W 63_15	P80	BXN80MB4	138
102	57	1.1	14	1690					VF 49_14	P80	BXN80MB4	130
119	47	1.0	24	1710								
119	51	2.7	12	2740	W63_12	S20	MXN20MB4	136	W 63_12	P80	BXN80MB4	138
134	46	2.8	7	2590								
143	42	1.4	10	1540					VF 49_10	P80	BXN80MB4	130
143	43	3.3	10	2600	W63_10	S20	MXN20MB4	136	W 63_10	P80	BXN80MB4	138
190	32	3.9	15	2440								
204	30	1.8	7	1400					VF 49_7	P80	BXN80MB4	130
204	31	3.9	7	2340	W63_7	S20	MXN20MB4	136	W 63_7	P80	BXN80MB4	138
285	21	2.1	10	1340								
407	15.5	2.7	7	1200								

1.1 kW

n ₂ min ⁻¹	M ₂ Nm	S	i	R _{n2} N	 IE2		 IE3		 IEC				
					W	S2			BE100M6	BE90S4			
0.30	7126	0.9	3200	34500					VF/VF 130/210_3200	P100	BE100M6	180	
0.30	6769	1.3	3200	52000					VF/VF 130/250_3200	P100	BE100M6	186	
0.37	6841	0.9	2560	34500					VF/VF 130/210_2560	P100	BE100M6	180	
0.37	6555	1.4	2560	52000					VF/VF 130/250_2560	P100	BE100M6	186	
0.45	5213	1.2	3200	34500					VF/VF 130/210_3200	P90	BE90S4	BX90S4	180
0.45	4975	1.8	3200	52000					VF/VF 130/250_3200	P90	BE90S4	BX90S4	186
0.51	6965	0.9	1840	34500					VF/VF 130/210_1840	P100	BE100M6	180	
0.51	5941	1.5	1840	52000					VF/VF 130/250_1840	P100	BE100M6	186	
0.56	4549	1.4	2560	34500					VF/VF 130/210_2560	P90	BE90S4	BX90S4	180
0.56	4738	1.9	2560	52000					VF/VF 130/250_2560	P90	BE90S4	BX90S4	186
0.78	4631	0.9	1840	19500					W /VF 86/185_1840	P90	BE90S4	BX90S4	174
0.78	4768	1.3	1840	34500					VF/VF 130/210_1840	P90	BE90S4	BX90S4	180
0.78	4223	2.1	1840	52000					VF/VF 130/250_1840	P90	BE90S4	BX90S4	186
0.90	4146	1.0	1600	19500					W /VF 86/185_1600	P90	BE90S4	BX90S4	174
1.0	3892	1.1	920	19500					W /VF 86/185_920	P100	BE100M6	174	
1.2	3020	1.4	1200	19500					W /VF 86/185_1200	P90	BE90S4	BX90S4	174
1.5	2860	1.4	920	19500					W /VF 86/185_920	P90	BE90S4	BX90S4	174
1.8	2547	1.6	800	19500					W /VF 86/185_800	P90	BE90S4	BX90S4	174
2.0	2554	1.0	690	16000					W /VF 86/150_690	P90	BE90S4	BX90S4	166
2.3	1777	1.0	600	13800					W /VF 63/130_600	P90	BE90S4	BX90S4	158
2.3	1999	2.1	600	19500					W /VF 86/185_600	P90	BE90S4	BX90S4	174
2.7	2154	1.2	529	16000					W /VF 86/150_529	P90	BE90S4	BX90S4	166
3.1	1873	1.4	460	16000					W /VF 86/150_460	P90	BE90S4	BX90S4	166
3.2	1670	1.4	300	19500					VFR 185_300	P100	BE100M6	170	
3.6	1303	1.4	400	13800					W /VF 63/130_400	P90	BE90S4	BX90S4	158
3.6	1422	2.9	400	19500					W /VF 86/185_400	P90	BE90S4	BX90S4	174
3.9	1443	1.1	240	16000					VFR 150_240	P100	BE100M6	162	
3.9	1443	1.9	240	19500					VFR 185_240	P100	BE100M6	170	
4.2	1481	1.7	345	16000					W /VF 86/150_345	P90	BE90S4	BX90S4	166
4.8	1206	1.1	300	16000					VFR 150_300	P90	BE90S4	BX90S4	162
4.8	1221	1.9	300	19500					VFR 185_300	P90	BE90S4	BX90S4	170
4.8	1289	2.0	300	16000					W /VF 86/150_300	P90	BE90S4	BX90S4	166
4.9	1240	1.0	192	13800					VFR 130_192	P100	BE100M6	154	
5.1	1037	1.7	280	13800					W /VF 63/130_280	P90	BE90S4	BX90S4	158
5.9	1012	1.1	240	13800					VFR 130_240	P90	BE90S4	BX90S4	154
5.9	1030	1.5	240	16000					VFR 150_240	P90	BE90S4	BX90S4	162
5.9	1049	2.6	240	19500					VFR 185_240	P90	BE90S4	BX90S4	170
6.3	1050	2.4	225	16000					W /VF 86/150_225	P90	BE90S4	BX90S4	166



1.1 kW

n ₂ min ⁻¹	M ₂ Nm	S	i	R _{n2} N										
					IE2	IE3			IE2	IE3				
6.8	983	1.5	138	13800				VFR 130_138	P100	BE100M6		154		
6.8	983	2.3	138	16000				VFR 150_138	P100	BE100M6		162		
7.2	947	2.7	200	16000				W /VF 86/150_200	P90	BE90S4	BX90S4	166		
7.5	867	1.4	192	13800				VFR 130_192	P90	BE90S4	BX90S4	154		
7.5	881	1.9	192	16000				VFR 150_192	P90	BE90S4	BX90S4	162		
7.9	869	1.0	120	8000				WR 110_120	P100	BE100M6		150		
8.0	866	3.4	180	19500				VFR 185_180	P90	BE90S4	BX90S4	170		
8.5	796	1.5	168	13800				VFR 130_168	P90	BE90S4	BX90S4	154		
8.5	808	2.1	168	16000				VFR 150_168	P90	BE90S4	BX90S4	162		
9.5	657	1.2	100	13200				VF 130_100	P100	BE100M6		152		
10.3	674	1.1	138	8000				WR 110_138	P90	BE90S4	BX90S4	150		
10.3	685	1.9	138	13800				VFR 130_138	P90	BE90S4	BX90S4	154		
10.3	695	2.8	138	16000				VFR 150_138	P90	BE90S4	BX90S4	162		
10.5	661	1.4	90	8000				WR 110_90	P100	BE100M6		150		
11.8	570	1.6	80	13200				VF 130_80	P100	BE100M6		152		
12.0	604	1.3	120	8000				WR 110_120	P90	BE90S4	BX90S4	150		
12.0	595	2.3	120	13800				VFR 130_120	P90	BE90S4	BX90S4	154		
12.0	604	3.3	120	16000				VFR 150_120	P90	BE90S4	BX90S4	162		
14.3	459	1.0	100	8000	W110_100	S3	ME3SA4	MX3SA4	148	W 110_100	P90	BE90S4	BX90S4	149
14.3	518	1.1	100	12600				VF 130_100	P90	BE90S4	BX90S4	152		
15.9	467	1.8	90	8000				WR 110_90	P90	BE90S4	BX90S4	150		
15.9	473	3.1	90	13800				VFR 130_90	P90	BE90S4	BX90S4	154		
17.9	391	1.2	80	8000	W110_80	S3	ME3SA4	MX3SA4	148	W 110_80	P90	BE90S4	BX90S4	149
17.9	403	2.2	80	12600				VF 130_80	P90	BE90S4	BX90S4	152		
20.5	353	1.0	46	7000	W86_46	S3	ME3LA6		144	W 86_46	P100	BE100M6		145
20.5	373	3.1	46	13200				VF 130_46	P100	BE100M6		152		
20.7	383	1.0	69	7000				WR 86_69	P90	BE90S4	BX90S4	146		
20.7	394	1.6	69	8000				WR 110_69	P90	BE90S4	BX90S4	150		
20.7	388	3.3	69	13800				VFR 130_69	P90	BE90S4	BX90S4	154		
22.4	332	1.6	64	8000	W110_64	S3	ME3SA4	MX3SA4	148	W 110_64	P90	BE90S4	BX90S4	149
22.4	336	2.7	64	12600				VF 130_64	P90	BE90S4	BX90S4	152		
23.6	316	1.1	40	7000	W86_40	S3	ME3LA6		144	W 86_40	P100	BE100M6		145
23.8	342	1.1	60	7000				WR 86_60	P90	BE90S4	BX90S4	146		
23.8	351	1.9	60	8000				WR 110_60	P90	BE90S4	BX90S4	150		
25.5	290	1.0	56	7000	W86_56	S3	ME3SA4	MX3SA4	144	W 86_56	P90	BE90S4	BX90S4	145
25.5	299	2.0	56	8000	W110_56	S3	ME3SA4	MX3SA4	148	W 110_56	P90	BE90S4	BX90S4	149
25.5	303	3.1	56	12600				VF 130_56	P90	BE90S4	BX90S4	152		
31	249	1.4	46	7000	W86_46	S3	ME3SA4	MX3SA4	144	W 86_46	P90	BE90S4	BX90S4	145
31	252	2.4	46	8000	W110_46	S3	ME3SA4	MX3SA4	148	W 110_46	P90	BE90S4	BX90S4	149
32	266	1.1	45	5010				WR 75_45	P90	BE90S4	BX90S4	142		
32	259	1.5	45	7000				WR 86_45	P90	BE90S4	BX90S4	146		
32	266	2.7	45	8000				WR 110_45	P90	BE90S4	BX90S4	150		
36	213	1.2	40	4980	W75_40	S3	ME3SA4	MX3SA4	140	W 75_40	P90	BE90S4	BX90S4	141
36	222	1.5	40	7000	W86_40	S3	ME3SA4	MX3SA4	144	W 86_40	P90	BE90S4	BX90S4	145
36	225	3.0	40	8000	W110_40	S3	ME3SA4	MX3SA4	148	W 110_40	P90	BE90S4	BX90S4	149
38	214	1.3	38	4790				WR 75_37.5	P90	BE90S4	BX90S4	142		
41	205	1.6	23	7000	W86_23	S3	ME3LA6		144	W 86_23	P100	BE100M6		145
41	204	1.7	35	7000				WR 86_34.5	P90	BE90S4	BX90S4	146		
48	165	1.0	30	3130				W 63_30	P90	BE90S4	BX90S4	138		
48	186	1.5	30	4530				WR 75_30	P90	BE90S4	BX90S4	142		
48	171	1.6	30	4640	W75_30	S3	ME3SA4	MX3SA4	140	W 75_30	P90	BE90S4	BX90S4	141
48	183	1.9	30	7000				WR 86_30	P90	BE90S4	BX90S4	146		
48	169	2.2	30	7000	W86_30	S3	ME3SA4	MX3SA4	144	W 86_30	P90	BE90S4	BX90S4	145
57	148	1.7	25	4420	W75_25	S3	ME3SA4	MX3SA4	140	W 75_25	P90	BE90S4	BX90S4	141
59	138	1.1	24	2990				W 63_24	P90	BE90S4	BX90S4	138		
62	140	2.3	23	7000	W86_23	S3	ME3SA4	MX3SA4	144	W 86_23	P90	BE90S4	BX90S4	145
72	123	2.0	20	4160	W75_20	S3	ME3SA4	MX3SA4	140	W 75_20	P90	BE90S4	BX90S4	141
72	124	2.6	20	7000	W86_20	S3	ME3SA4	MX3SA4	144	W 86_20	P90	BE90S4	BX90S4	145
76	113	1.3	19	2840				W 63_19	P90	BE90S4	BX90S4	138		
95	92	1.6	15	2690				W 63_15	P90	BE90S4	BX90S4	138		
95	95	2.6	15	3850	W75_15	S3	ME3SA4	MX3SA4	140	W 75_15	P90	BE90S4	BX90S4	141
95	95	3.4	15	6820	W86_15	S3	ME3SA4	MX3SA4	144	W 86_15	P90	BE90S4	BX90S4	145
119	75	1.9	12	2550				W 63_12	P90	BE90S4	BX90S4	138		
143	64	2.2	10	2440				W 63_10	P90	BE90S4	BX90S4	138		
143	65	3.5	10	3420	W75_10	S3	ME3SA4	MX3SA4	140	W 75_10	P90	BE90S4	BX90S4	141
189	47	2.6	15	2330	W63_15	S2	ME2SB2		136	W 63_15	P80	BE80B2		138
204	45	2.6	7	2210				W 63_7	P90	BE90S4	BX90S4	138		
236	38	3.3	12	2190	W63_12	S2	ME2SB2		136	W 63_12	P80	BE80B2		138
283	32	3.9	10	2080	W63_10	S2	ME2SB2		136	W 63_10	P80	BE80B2		138





1.1 kW



n ₂ min ⁻¹	M ₂ Nm	S	i	R _{n2} N	IE3		IEC		
0.30	7126	0.9	3200	34500					
0.30	6769	1.3	3200	52000					
0.37	6841	0.9	2560	34500					
0.37	6555	1.4	2560	52000					
0.45	5213	1.2	3200	34500			VF/VF 130/210_3200	P90 BXN90S4	180
0.45	4975	1.8	3200	52000			VF/VF 130/250_3200	P90 BXN90S4	186
0.51	6965	0.9	1840	34500					
0.51	5941	1.5	1840	52000					
0.56	4549	1.4	2560	34500			VF/VF 130/210_2560	P90 BXN90S4	180
0.56	4738	1.9	2560	52000			VF/VF 130/250_2560	P90 BXN90S4	186
0.78	4631	0.9	1840	19500			W /VF 86/185_1840	P90 BXN90S4	174
0.78	4768	1.3	1840	34500			VF/VF 130/210_1840	P90 BXN90S4	180
0.78	4223	2.1	1840	52000			VF/VF 130/250_1840	P90 BXN90S4	186
0.90	4146	1.0	1600	19500			W /VF 86/185_1600	P90 BXN90S4	174
1.0	3892	1.1	920	19500					
1.2	3020	1.4	1200	19500			W /VF 86/185_1200	P90 BXN90S4	174
1.5	2860	1.4	920	19500			W /VF 86/185_920	P90 BXN90S4	174
1.8	2547	1.6	800	19500			W /VF 86/185_800	P90 BXN90S4	174
2.0	2554	1.0	690	16000			W /VF 86/150_690	P90 BXN90S4	166
2.3	1777	1.0	600	13800			W /VF 63/130_600	P90 BXN90S4	158
2.3	1999	2.1	600	19500			W /VF 86/185_600	P90 BXN90S4	174
2.7	2154	1.2	529	16000			W /VF 86/150_529	P90 BXN90S4	166
3.1	1873	1.4	460	16000			W /VF 86/150_460	P90 BXN90S4	166
3.2	1670	1.4	300	19500					
3.6	1303	1.4	400	13800			W /VF 63/130_400	P90 BXN90S4	158
3.6	1422	2.9	400	19500			W /VF 86/185_400	P90 BXN90S4	174
3.9	1443	1.1	240	16000					
3.9	1443	1.9	240	19500					
4.2	1481	1.7	345	16000			W /VF 86/150_345	P90 BXN90S4	166
4.8	1206	1.1	300	16000			VFR 150_300	P90 BXN90S4	162
4.8	1221	1.9	300	19500			VFR 185_300	P90 BXN90S4	170
4.8	1289	2.0	300	16000			W /VF 86/150_300	P90 BXN90S4	166
4.9	1240	1.0	192	13800					
5.1	1037	1.7	280	13800			W /VF 63/130_280	P90 BXN90S4	158
5.9	1012	1.1	240	13800			VFR 130_240	P90 BXN90S4	154
5.9	1030	1.5	240	16000			VFR 150_240	P90 BXN90S4	162
5.9	1049	2.6	240	19500			VFR 185_240	P90 BXN90S4	170
6.3	1050	2.4	225	16000			W /VF 86/150_225	P90 BXN90S4	166
6.8	983	1.5	138	13800					
6.8	983	2.3	138	16000					
7.2	947	2.7	200	16000			W /VF 86/150_200	P90 BXN90S4	166
7.5	867	1.4	192	13800			VFR 130_192	P90 BXN90S4	154
7.5	881	1.9	192	16000			VFR 150_192	P90 BXN90S4	162
7.9	869	1.0	120	8000					
8.0	866	3.4	180	19500			VFR 185_180	P90 BXN90S4	170
8.5	796	1.5	168	13800			VFR 130_168	P90 BXN90S4	154
8.5	808	2.1	168	16000			VFR 150_168	P90 BXN90S4	162
9.5	657	1.2	100	13200					
10.3	674	1.1	138	8000			WR 110_138	P90 BXN90S4	150
10.3	685	1.9	138	13800			VFR 130_138	P90 BXN90S4	154
10.3	695	2.8	138	16000			VFR 150_138	P90 BXN90S4	162
10.5	661	1.4	90	8000					
11.8	570	1.6	80	13200					
12.0	604	1.3	120	8000			WR 110_120	P90 BXN90S4	150
12.0	595	2.3	120	13800			VFR 130_120	P90 BXN90S4	154
12.0	604	3.3	120	16000			VFR 150_120	P90 BXN90S4	162
14.3	459	1.0	100	8000			W 110_100	P90 BXN90S4	149
14.3	518	1.1	100	12600			VF 130_100	P90 BXN90S4	152
15.9	467	1.8	90	8000			WR 110_90	P90 BXN90S4	150
15.9	473	3.1	90	13800			VFR 130_90	P90 BXN90S4	154
17.9	391	1.2	80	8000			W 110_80	P90 BXN90S4	149
17.9	403	2.2	80	12600			VF 130_80	P90 BXN90S4	152
20.5	353	1.0	46	7000					
20.5	373	3.1	46	13200					
20.7	383	1.0	69	7000			WR 86_69	P90 BXN90S4	146
20.7	394	1.6	69	8000			WR 110_69	P90 BXN90S4	150
20.7	388	3.3	69	13800			VFR 130_69	P90 BXN90S4	154
22.4	332	1.6	64	8000			W 110_64	P90 BXN90S4	149
22.4	336	2.7	64	12600			VF 130_64	P90 BXN90S4	152
23.6	316	1.1	40	7000					

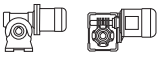

1.1 kW



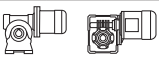



n ₂ min ⁻¹	M ₂ Nm	S	i	R _{n2} N	 IE3		 IEC			
23.8	342	1.1	60	7000			WR 86_60	P90	BXN90S4	146
23.8	351	1.9	60	8000			WR 110_60	P90	BXN90S4	150
25.5	290	1.0	56	7000			W 86_56	P90	BXN90S4	145
25.5	299	2.0	56	8000			W 110_56	P90	BXN90S4	149
25.5	303	3.1	56	12600			VF 130_56	P90	BXN90S4	152
31	249	1.4	46	7000			W 86_46	P90	BXN90S4	145
31	252	2.4	46	8000			W 110_46	P90	BXN90S4	149
32	266	1.1	45	5010			WR 75_45	P90	BXN90S4	142
32	259	1.5	45	7000			WR 86_45	P90	BXN90S4	146
32	266	2.7	45	8000			WR 110_45	P90	BXN90S4	150
36	213	1.2	40	4980			W 75_40	P90	BXN90S4	141
36	222	1.5	40	7000			W 86_40	P90	BXN90S4	145
36	225	3.0	40	8000			W 110_40	P90	BXN90S4	149
38	214	1.3	38	4790			WR 75_37.5	P90	BXN90S4	142
41	205	1.6	23	7000						
41	204	1.7	35	7000			WR 86_34.5	P90	BXN90S4	146
48	165	1.0	30	3130			W 63_30	P90	BXN90S4	138
48	186	1.5	30	4530			WR 75_30	P90	BXN90S4	142
48	171	1.6	30	4640			W 75_30	P90	BXN90S4	141
48	183	1.9	30	7000			WR 86_30	P90	BXN90S4	146
48	169	2.2	30	7000			W 86_30	P90	BXN90S4	145
57	148	1.7	25	4420			W 75_25	P90	BXN90S4	141
59	138	1.1	24	2990			W 63_24	P90	BXN90S4	138
62	140	2.3	23	7000			W 86_23	P90	BXN90S4	145
72	123	2.0	20	4160			W 75_20	P90	BXN90S4	141
72	124	2.6	20	7000			W 86_20	P90	BXN90S4	145
76	113	1.3	19	2840			W 63_19	P90	BXN90S4	138
95	92	1.6	15	2690			W 63_15	P90	BXN90S4	138
95	95	2.6	15	3850			W 75_15	P90	BXN90S4	141
95	95	3.4	15	6820			W 86_15	P90	BXN90S4	145
119	75	1.9	12	2550			W 63_12	P90	BXN90S4	138
143	64	2.2	10	2440			W 63_10	P90	BXN90S4	138
143	65	3.5	10	3420			W 75_10	P90	BXN90S4	141
189	47	2.6	15	2330						
204	45	2.6	7	2210			W 63_7	P90	BXN90S4	138
236	38	3.3	12	2190						
283	32	3.9	10	2080						

1.5 kW

n ₂ min ⁻¹	M ₂ Nm	S	i	R _{n2} N	 IE2 IE3		 IEC			
0.30	9240	1.0	3200	52000			VF/VF 130/250_3200	P100	BE100LA6	172
0.37	8948	1.0	2560	52000			VF/VF 130/250_2560	P100	BE100LA6	172
0.45	7012	0.9	3200	34500			VF/VF 130/210_3200	P90	BE90LA4 BX90LA4	166
0.45	6693	1.3	3200	52000			VF/VF 130/250_3200	P90	BE90LA4 BX90LA4	172
0.51	8109	1.1	1840	52000			VF/VF 130/250_1840	P100	BE100LA6	172
0.56	6120	1.0	2560	34500			VF/VF 130/210_2560	P90	BE90LA4 BX90LA4	166
0.56	6375	1.4	2560	52000			VF/VF 130/250_2560	P90	BE90LA4 BX90LA4	172
0.78	6415	1.0	1840	34500			VF/VF 130/210_1840	P90	BE90LA4 BX90LA4	166
0.78	5681	1.6	1840	52000			VF/VF 130/250_1840	P90	BE90LA4 BX90LA4	172
1.0	4893	1.3	920	34500			VF/VF 130/210_920	P100	BE100LA6	166
1.0	4893	1.9	920	52000			VF/VF 130/250_920	P100	BE100LA6	172
1.2	4064	1.0	1200	19500			W /VF 86/185_1200	P90	BE90LA4 BX90LA4	160
1.2	4620	1.4	800	34500			VF/VF 130/210_800	P100	BE100LA6	166
1.2	4863	1.9	800	52000			VF/VF 130/250_800	P100	BE100LA6	172
1.5	3849	1.1	920	19500			W /VF 86/185_920	P90	BE90LA4 BX90LA4	160
1.6	3921	1.7	600	34500			VF/VF 130/210_600	P100	BE100LA6	166
1.6	3921	2.3	600	52000			VF/VF 130/250_600	P100	BE100LA6	172
1.8	3426	1.2	800	19500			W /VF 86/185_800	P90	BE90LA4 BX90LA4	160
2.4	2689	1.5	600	19500			W /VF 86/185_600	P90	BE90LA4 BX90LA4	160
2.4	2918	2.2	400	34500			VF/VF 130/210_400	P100	BE100LA6	166
2.4	2857	3.2	400	52000			VF/VF 130/250_400	P100	BE100LA6	172







1.5 kW



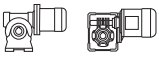

n ₂ min ⁻¹	M ₂ Nm	S	i	R _{n2} N	 			 					
					IE2	IE3		IE2	IE2				
2.7	2898	0.9	529	16000				W /VF 86/150_529	P90	BE90LA4	BX90LA4	152	
3.1	2520	1.0	460	16000				W /VF 86/150_460	P90	BE90LA4	BX90LA4	152	
3.2	2280	1.0	300	19500				VFR 185_300	P100	BE100LA6		156	
3.2	2234	1.6	300	34500				VFR 210_300	P100	BE100LA6		164	
3.2	2370	2.2	300	52000				VFR 250_300	P100	BE100LA6		170	
3.4	2128	3.0	280	34500				VF/VF 130/210_280	P100	BE100LA6		166	
3.5	1753	1.0	400	13800				W /VF 63/130_400	P90	BE90LA4	BX90LA4	144	
3.5	1913	2.2	400	19500				W /VF 86/185_400	P90	BE90LA4	BX90LA4	160	
3.9	1969	0.9	240	16000				VFR 150_240	P100	BE100LA6		148	
3.9	1969	1.4	240	19500				VFR 185_240	P100	BE100LA6		156	
3.9	1969	2.2	240	34500				VFR 210_240	P100	BE100LA6		164	
4.2	1993	1.3	345	16000				W /VF 86/150_345	P90	BE90LA4	BX90LA4	152	
4.8	1643	1.4	300	19500				VFR 185_300	P90	BE90LA4	BX90LA4	156	
4.8	1733	1.5	300	16000				W /VF 86/150_300	P90	BE90LA4	BX90LA4	152	
4.9	1721	1.1	192	16000				VFR 150_192	P100	BE100LA6		148	
5.1	1394	1.3	280	13800				W /VF 63/130_280	P90	BE90LA4	BX90LA4	144	
5.1	1450	2.9	280	19500				W /VF 86/185_280	P90	BE90LA4	BX90LA4	160	
5.3	1641	2.0	180	19500				VFR 185_180	P100	BE100LA6		156	
5.3	1477	3.3	180	34500				VFR 210_180	P100	BE100LA6		164	
5.6	1532	0.9	168	13800				VFR 130_168	P100	BE100LA6		140	
6.0	1386	1.1	240	16000				VFR 150_240	P90	BE90LA4	BX90LA4	148	
6.0	1411	1.9	240	19500				VFR 185_240	P90	BE90LA4	BX90LA4	156	
6.4	1412	1.8	225	16000				W /VF 86/150_225	P90	BE90LA4	BX90LA4	152	
7.2	1275	2.0	200	16000				W /VF 86/150_200	P90	BE90LA4	BX90LA4	152	
7.4	1167	1.0	192	13800				VFR 130_192	P90	BE90LA4	BX90LA4	140	
7.4	1185	1.4	192	16000				VFR 150_192	P90	BE90LA4	BX90LA4	148	
7.9	1166	2.6	180	19500				VFR 185_180	P90	BE90LA4	BX90LA4	156	
8.5	1071	1.1	168	13800				VFR 130_168	P90	BE90LA4	BX90LA4	140	
8.5	1087	1.6	168	16000				VFR 150_168	P90	BE90LA4	BX90LA4	148	
9.5	927	1.2	100	15500				VF 150_100	P100	BE100LA6		146	
9.5	942	2.1	100	19500				VF 185_100	P100	BE100LA6		154	
9.5	1001	3.3	150	16000				VFR 185_150	P90	BE90LA4	BX90LA4	156	
10.3	921	1.4	138	13800				VFR 130_138	P90	BE90LA4	BX90LA4	140	
10.3	934	2.1	138	16000				VFR 150_138	P90	BE90LA4	BX90LA4	148	
10.5	902	1.0	90	8000				WR 110_90	P100	BE100LA6		136	
10.5	998	3.2	90	19500				VFR 185_90	P100	BE100LA6		156	
11.8	778	1.2	80	13200				VF 130_80	P100	BE100LA6		138	
11.8	790	1.7	80	15500				VF 150_80	P100	BE100LA6		146	
11.9	816	1.0	120	8000				WR 110_120	P90	BE90LA4	BX90LA4	136	
12.0	801	1.7	120	13800				VFR 130_120	P90	BE90LA4	BX90LA4	140	
12.0	813	2.4	120	16000				VFR 150_120	P90	BE90LA4	BX90LA4	148	
13.7	787	1.0	69	8000				WR 110_69	P100	BE100LA6		136	
13.7	776	1.9	69	13800				VFR 130_69	P100	BE100LA6		140	
13.7	776	2.6	69	16000				VFR 150_69	P100	BE100LA6		148	
14.8	671	2.2	64	15500				VF 150_64	P100	BE100LA6		146	
15.9	627	1.3	90	8000				WR 110_90	P90	BE90LA4	BX90LA4	136	
15.9	636	2.3	90	13800				VFR 130_90	P90	BE90LA4	BX90LA4	140	
15.9	645	3.1	90	16000				VFR 150_90	P90	BE90LA4	BX90LA4	148	
16.9	578	1.1	56	8000	W110_56	S3	ME3LB6	148	W 110_56	P100	BE100LA6	135	
16.9	595	1.8	56	13200				VF 130_56	P100	BE100LA6		138	
16.9	604	2.5	56	15500				VF 150_56	P100	BE100LA6		146	
17.8	542	1.6	80	12600				VF 130_80	P90	BE90LA4	BX90LA4	138	
20.5	497	1.3	46	8000	W110_46	S3	ME3LB6	148	W 110_46	P100	BE100LA6	135	
20.5	518	3.4	46	15500				VF 150_46	P100	BE100LA6		146	
20.7	529	1.2	69	8000				WR 110_69	P90	BE90LA4	BX90LA4	136	
20.7	523	2.4	69	13800				VFR 130_69	P90	BE90LA4	BX90LA4	140	
20.7	529	3.5	69	16000				VFR 150_69	P90	BE90LA4	BX90LA4	148	
22.3	446	1.2	64	8000	W110_64	S3	ME3SB4	MX3SB4	148	W 110_64	P90	BE90LA4	135
22.3	453	2.0	64	12600				VF 130_64	P90	BE90LA4	BX90LA4	138	
23.6	444	2.7	40	13200				VF 130_40	P100	BE100LA6		138	



1.5 kW

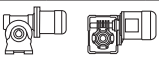

n ₂ min-1	M ₂ Nm	S	i	R _{n2} N	 IE2 IE3				 IEC IE2 IE2					
					W	S	ME		MX	W	P		BE	BX
23.8	473	1.4	60	8000					WR 110_60	P90	BE90LA4	BX90LA4	136	
23.8	466	2.9	60	13800					VFR 130_60	P90	BE90LA4	BX90LA4	140	
25.6	402	1.5	56	8000	W110_56	S3	ME3SB4	MX3SB4	148	W 110_56	P90	BE90LA4	BX90LA4	135
25.6	407	2.3	56	12600					VF 130_56	P90	BE90LA4	BX90LA4	138	
31	334	1.0	46	7000	W86_46	S3	ME3SB4	MX3SB4	144	W 86_46	P90	BE90LA4	BX90LA4	131
31	339	1.8	46	8000	W110_46	S3	ME3SB4	MX3SB4	148	W 110_46	P90	BE90LA4	BX90LA4	135
31	348	3.1	46	12600					VF 130_46	P90	BE90LA4	BX90LA4	138	
32	350	1.1	45	7000					WR 86_45	P90	BE90LA4	BX90LA4	132	
32	359	2.0	45	8000					WR 110_45	P90	BE90LA4	BX90LA4	136	
35	299	1.1	40	7000	W86_40	S3	ME3SB4	MX3SB4	144	W 86_40	P90	BE90LA4	BX90LA4	131
35	303	2.2	40	8000	W110_40	S3	ME3SB4	MX3SB4	148	W 110_40	P90	BE90LA4	BX90LA4	135
38	292	0.9	25	4330	W75_25	S3	ME3LB6		140	W 75_25	P100	BE100LA6		127
38	287	0.9	38	4330					WR 75_37.5	P90	BE90LA4	BX90LA4	128	
41	279	1.2	23	7000	W86_23	S3	ME3LB6		144	W 86_23	P100	BE100LA6		131
41	275	1.3	35	7000					WR 86_34.5	P90	BE90LA4	BX90LA4	132	
48	251	1.1	30	4130					WR 75_30	P90	BE90LA4	BX90LA4	128	
48	230	1.2	30	4270	W75_30	S3	ME3SB4	MX3SB4	140	W 75_30	P90	BE90LA4	BX90LA4	127
48	245	1.4	30	7000					WR 86_30	P90	BE90LA4	BX90LA4	132	
48	227	1.6	30	7000	W86_30	S3	ME3SB4	MX3SB4	144	W 86_30	P90	BE90LA4	BX90LA4	131
48	230	3.1	30	8000	W110_30	S3	ME3SB4	MX3SB4	148	W 110_30	P90	BE90LA4	BX90LA4	135
57	199	1.3	25	4100	W75_25	S3	ME3SB4	MX3SB4	140	W 75_25	P90	BE90LA4	BX90LA4	127
62	188	1.7	23	7000	W86_23	S3	ME3SB4	MX3SB4	144	W 86_23	P90	BE90LA4	BX90LA4	131
62	190	2.8	23	8000	W110_23	S3	ME3SB4	MX3SB4	148	W 110_23	P90	BE90LA4	BX90LA4	135
72	166	1.5	20	3880	W75_20	S3	ME3SB4	MX3SB4	140	W 75_20	P90	BE90LA4	BX90LA4	127
72	168	1.9	20	7000	W86_20	S3	ME3SB4	MX3SB4	144	W 86_20	P90	BE90LA4	BX90LA4	131
72	168	3.4	20	8000	W110_20	S3	ME3SB4	MX3SB4	148	W 110_20	P90	BE90LA4	BX90LA4	135
75	153	1.0	19	2550					W 63_19	P90	BE90LA4	BX90LA4	124	
95	124	1.2	15	2450					W 63_15	P90	BE90LA4	BX90LA4	124	
95	127	2.0	15	3630	W75_15	S3	ME3SB4	MX3SB4	140	W 75_15	P90	BE90LA4	BX90LA4	127
95	128	2.4	15	6520					WR 86_15	P90	BE90LA4	BX90LA4	132	
95	127	2.6	15	6610	W86_15	S3	ME3SB4	MX3SB4	144	W 86_15	P90	BE90LA4	BX90LA4	131
120	102	1.4	12	2340					W 63_12	P90	BE90LA4	BX90LA4	124	
135	94	2.2	7	3150	W75_7	S3	ME3LB6		140	W 75_7	P100	BE100LA6		127
143	85	1.6	10	2250					W 63_10	P90	BE90LA4	BX90LA4	124	
143	87	2.6	10	3250	W75_10	S3	ME3SB4	MX3SB4	140	W 75_10	P90	BE90LA4	BX90LA4	127
143	87	3.3	10	5850	W86_10	S3	ME3SB4	MX3SB4	144	W 86_10	P90	BE90LA4	BX90LA4	131
190	65	1.9	15	2200					W 63_15	P90	BE90SA2		124	
190	67	3.4	15	3120	W75_15	S3	ME3SA2		140	W 75_15	P90	BE90SA2		127
204	62	1.9	7	2060					W 63_7	P90	BE90LA4	BX90LA4	124	
204	63	3.1	7	2920	W75_7	S3	ME3SB4	MX3SB4	140	W 75_7	P90	BE90LA4	BX90LA4	127
204	62	4.0	7	5240	W86_7	S3	ME3SB4	MX3SB4	144	W 86_7	P90	BE90LA4	BX90LA4	131
238	52	2.4	12	2080					W 63_12	P90	BE90SA2		124	
286	44	2.8	10	1980	W63_10	S3	ME3SA2		136	W 63_10	P90	BE90SA2		124

1.5 kW

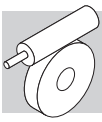
n ₂ min-1	M ₂ Nm	S	i	R _{n2} N	 IE3				 IEC IE3				
					W	P	BX						
0.30	9240	1.0	3200	52000									
0.37	8948	1.0	2560	52000									
0.45	7012	0.9	3200	34500					VF/VF 130/210_3200	P90	BXN90L4		180
0.45	6693	1.3	3200	52000					VF/VF 130/250_3200	P90	BXN90L4		186
0.51	8109	1.1	1840	52000									
0.56	6120	1.0	2560	34500					VF/VF 130/210_2560	P90	BXN90L4		180
0.56	6375	1.4	2560	52000					VF/VF 130/250_2560	P90	BXN90L4		186
0.78	6415	1.0	1840	34500					VF/VF 130/210_1840	P90	BXN90L4		180
0.78	5681	1.6	1840	52000					VF/VF 130/250_1840	P90	BXN90L4		186

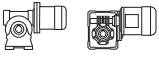

1.5 kW

n ₂ min-1	M ₂ Nm	S	i	R _{n2} N	 IE3		 IEC			
					W /VF	P90	BXN90L4			
1.0	4893	1.3	920	34500						
1.0	4893	1.9	920	52000						
1.2	4064	1.0	1200	19500			W /VF 86/185_1200	P90	BXN90L4	174
1.2	4620	1.4	800	34500						
1.2	4863	1.9	800	52000						
1.5	3849	1.1	920	19500			W /VF 86/185_920	P90	BXN90L4	174
1.6	3921	1.7	600	34500						
1.6	3921	2.3	600	52000						
1.8	3426	1.2	800	19500			W /VF 86/185_800	P90	BXN90L4	174
2.4	2689	1.5	600	19500			W /VF 86/185_600	P90	BXN90L4	174
2.4	2918	2.2	400	34500						
2.4	2857	3.2	400	52000						
2.7	2898	0.9	529	16000			W /VF 86/150_529	P90	BXN90L4	166
3.1	2520	1.0	460	16000			W /VF 86/150_460	P90	BXN90L4	166
3.2	2280	1.0	300	19500						
3.2	2234	1.6	300	34500						
3.2	2370	2.2	300	52000						
3.4	2128	3.0	280	34500						
3.5	1753	1.0	400	13800			W /VF 63/130_400	P90	BXN90L4	158
3.5	1913	2.2	400	19500			W /VF 86/185_400	P90	BXN90L4	174
3.9	1969	0.9	240	16000						
3.9	1969	1.4	240	19500						
3.9	1969	2.2	240	34500						
4.2	1993	1.3	345	16000			W /VF 86/150_345	P90	BXN90L4	166
4.8	1643	1.4	300	19500			VFR 185_300	P90	BXN90L4	170
4.8	1733	1.5	300	16000			W /VF 86/150_300	P90	BXN90L4	166
4.9	1721	1.1	192	16000						
5.1	1394	1.3	280	13800			W /VF 63/130_280	P90	BXN90L4	158
5.1	1450	2.9	280	19500			W /VF 86/185_280	P90	BXN90L4	174
5.3	1641	2.0	180	19500						
5.3	1477	3.3	180	34500						
5.6	1532	0.9	168	13800						
6.0	1386	1.1	240	16000			VFR 150_240	P90	BXN90L4	162
6.0	1411	1.9	240	19500			VFR 185_240	P90	BXN90L4	170
6.4	1412	1.8	225	16000			W /VF 86/150_225	P90	BXN90L4	166
7.2	1275	2.0	200	16000			W /VF 86/150_200	P90	BXN90L4	166
7.4	1167	1.0	192	13800			VFR 130_192	P90	BXN90L4	154
7.4	1185	1.4	192	16000			VFR 150_192	P90	BXN90L4	162
7.9	1166	2.6	180	19500			VFR 185_180	P90	BXN90L4	170
8.5	1071	1.1	168	13800			VFR 130_168	P90	BXN90L4	154
8.5	1087	1.6	168	16000			VFR 150_168	P90	BXN90L4	162
9.5	927	1.2	100	15500						
9.5	942	2.1	100	19500						
9.5	1001	3.3	150	16000			VFR 185_150	P90	BXN90L4	170
10.3	921	1.4	138	13800			VFR 130_138	P90	BXN90L4	154
10.3	934	2.1	138	16000			VFR 150_138	P90	BXN90L4	162
10.5	902	1.0	90	8000						
10.5	998	3.2	90	19500						
11.8	778	1.2	80	13200						
11.8	790	1.7	80	15500						
11.9	816	1.0	120	8000			WR 110_120	P90	BXN90L4	150
12.0	801	1.7	120	13800			VFR 130_120	P90	BXN90L4	154
12.0	813	2.4	120	16000			VFR 150_120	P90	BXN90L4	162
13.7	787	1.0	69	8000						
13.7	776	1.9	69	13800						
13.7	776	2.6	69	16000						
14.8	671	2.2	64	15500						
15.9	627	1.3	90	8000			WR 110_90	P90	BXN90L4	150
15.9	636	2.3	90	13800			VFR 130_90	P90	BXN90L4	154
15.9	645	3.1	90	16000			VFR 150_90	P90	BXN90L4	162

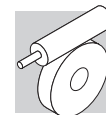

1.5 kW

n ₂ min ⁻¹	M ₂ Nm	S	i	R _{n2} N	IE3		IEC		
16.9	578	1.1	56	8000					
16.9	595	1.8	56	13200					
16.9	604	2.5	56	15500					
17.8	542	1.6	80	12600			VF 130_80	P90 BXN90L4	152
20.5	497	1.3	46	8000					
20.5	518	3.4	46	15500					
20.7	529	1.2	69	8000			WR 110_69	P90 BXN90L4	150
20.7	523	2.4	69	13800			VFR 130_69	P90 BXN90L4	154
20.7	529	3.5	69	16000			VFR 150_69	P90 BXN90L4	162
22.3	446	1.2	64	8000			W 110_64	P90 BXN90L4	149
22.3	453	2.0	64	12600			VF 130_64	P90 BXN90L4	152
23.6	444	2.7	40	13200					
23.8	473	1.4	60	8000			WR 110_60	P90 BXN90L4	150
23.8	466	2.9	60	13800			VFR 130_60	P90 BXN90L4	154
25.6	402	1.5	56	8000			W 110_56	P90 BXN90L4	149
25.6	407	2.3	56	12600			VF 130_56	P90 BXN90L4	152
31	334	1.0	46	7000			W 86_46	P90 BXN90L4	145
31	339	1.8	46	8000			W 110_46	P90 BXN90L4	149
31	348	3.1	46	12600			VF 130_46	P90 BXN90L4	152
32	350	1.1	45	7000			WR 86_45	P90 BXN90L4	146
32	359	2.0	45	8000			WR 110_45	P90 BXN90L4	150
35	299	1.1	40	7000			W 86_40	P90 BXN90L4	145
35	303	2.2	40	8000			W 110_40	P90 BXN90L4	149
38	292	0.9	25	4330					
38	287	0.9	38	4330			WR 75_37.5	P90 BXN90L4	142
41	279	1.2	23	7000					
41	275	1.3	35	7000			WR 86_34.5	P90 BXN90L4	146
48	251	1.1	30	4130			WR 75_30	P90 BXN90L4	142
48	230	1.2	30	4270			W 75_30	P90 BXN90L4	141
48	245	1.4	30	7000			WR 86_30	P90 BXN90L4	146
48	227	1.6	30	7000			W 86_30	P90 BXN90L4	145
48	230	3.1	30	8000			W 110_30	P90 BXN90L4	149
57	199	1.3	25	4100			W 75_25	P90 BXN90L4	141
62	188	1.7	23	7000			W 86_23	P90 BXN90L4	145
62	190	2.8	23	8000			W 110_23	P90 BXN90L4	149
72	166	1.5	20	3880			W 75_20	P90 BXN90L4	141
72	168	1.9	20	7000			W 86_20	P90 BXN90L4	145
72	168	3.4	20	8000			W 110_20	P90 BXN90L4	149
75	153	1.0	19	2550			W 63_19	P90 BXN90L4	138
95	124	1.2	15	2450			W 63_15	P90 BXN90L4	138
95	127	2.0	15	3630			W 75_15	P90 BXN90L4	141
95	128	2.4	15	6520			WR 86_15	P90 BXN90L4	146
95	127	2.6	15	6610			W 86_15	P90 BXN90L4	145
120	102	1.4	12	2340			W 63_12	P90 BXN90L4	138
135	94	2.2	7	3150					
143	85	1.6	10	2250			W 63_10	P90 BXN90L4	138
143	87	2.6	10	3250			W 75_10	P90 BXN90L4	141
143	87	3.3	10	5850			W 86_10	P90 BXN90L4	145
190	65	1.9	15	2200					
190	67	3.4	15	3120					
204	62	1.9	7	2060			W 63_7	P90 BXN90L4	138
204	63	3.1	7	2920			W 75_7	P90 BXN90L4	141
204	62	4.0	7	5240			W 86_7	P90 BXN90L4	145
238	52	2.4	12	2080					
286	44	2.8	10	1980					

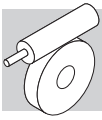

2.2 kW

n ₂ min-1	M ₂ Nm	S	i	R _{n2} N								
					IE2	IE3		IE2	IE3			
0.45	9879	0.9	3200	52000				VF/VF 130/250_3200	P100	BE100LA4	BX100LA4	186
0.56	9408	0.9	2560	52000				VF/VF 130/250_2560	P100	BE100LA4	BX100LA4	186
0.78	8385	1.1	1840	52000				VF/VF 130/250_1840	P100	BE100LA4	BX100LA4	186
0.89	7527	1.2	1600	52000				VF/VF 130/250_1600	P100	BE100LA4	BX100LA4	186
1.0	6884	0.9	920	34500				VF/VF 130/210_920	P112	BE112M6		180
1.0	6884	1.4	920	52000				VF/VF 130/250_920	P112	BE112M6		186
1.2	6174	1.0	1200	34500				VF/VF 130/210_1200	P100	BE100LA4	BX100LA4	180
1.2	6174	1.4	1200	52000				VF/VF 130/250_1200	P100	BE100LA4	BX100LA4	186
1.5	5004	1.2	920	34500				VF/VF 130/210_920	P100	BE100LA4	BX100LA4	180
1.5	5004	1.8	920	52000				VF/VF 130/250_920	P100	BE100LA4	BX100LA4	186
1.8	4821	1.3	800	34500				VF/VF 130/210_800	P100	BE100LA4	BX100LA4	180
1.8	4940	1.8	800	52000				VF/VF 130/250_800	P100	BE100LA4	BX100LA4	186
2.4	3969	1.0	600	19500				W /VF 86/185_600	P100	BE100LA4	BX100LA4	174
2.4	3792	1.6	600	34500				VF/VF 130/210_600	P100	BE100LA4	BX100LA4	180
2.4	3881	2.3	600	52000				VF/VF 130/250_600	P100	BE100LA4	BX100LA4	186
3.2	3143	1.2	300	34500				VFR 210_300	P112	BE112M6		178
3.2	3335	1.6	300	52000				VFR 250_300	P112	BE112M6		184
3.5	2823	1.5	400	19500				W /VF 86/185_400	P100	BE100LA4	BX100LA4	174
3.5	2940	2.1	400	34500				VF/VF 130/210_400	P100	BE100LA4	BX100LA4	180
3.5	2882	3.1	400	52000				VF/VF 130/250_400	P100	BE100LA4	BX100LA4	186
4.0	2771	1.0	240	19500				VFR 185_240	P112	BE112M6		170
4.0	2771	1.6	240	34500				VFR 210_240	P112	BE112M6		178
4.0	2873	2.0	240	52000				VFR 250_240	P112	BE112M6		184
4.8	2426	0.9	300	19500				VFR 185_300	P100	BE100LA4	BX100LA4	170
4.8	2426	1.4	300	34500				VFR 210_300	P100	BE100LA4	BX100LA4	178
4.8	2514	2.0	300	52000				VFR 250_300	P100	BE100LA4	BX100LA4	184
5.1	2141	1.9	280	19500				W /VF 86/185_280	P100	BE100LA4	BX100LA4	174
5.1	2141	2.9	280	34500				VF/VF 130/210_280	P100	BE100LA4	BX100LA4	180
5.7	2191	0.9	168	16000				VFR 150_168	P112	BE112M6		162
6.0	2082	1.3	240	19500				VFR 185_240	P100	BE100LA4	BX100LA4	170
6.0	2082	1.8	240	34500				VFR 210_240	P100	BE100LA4	BX100LA4	178
6.0	2152	2.5	240	52000				VFR 250_240	P100	BE100LA4	BX100LA4	184
7.4	1750	1.0	192	16000				VFR 150_192	P100	BE100LA4	BX100LA4	162
7.9	1720	1.7	180	19500				VFR 185_180	P100	BE100LA4	BX100LA4	170
7.9	1694	2.5	180	34500				VFR 210_180	P100	BE100LA4	BX100LA4	178
7.9	1773	3.5	180	52000				VFR 250_180	P100	BE100LA4	BX100LA4	184
8.0	1616	0.9	120	13800				VFR 130_120	P112	BE112M6		154
8.5	1605	1.1	168	16000				VFR 150_168	P100	BE100LA4	BX100LA4	162
9.5	1478	2.2	150	19500				VFR 185_150	P100	BE100LA4	BX100LA4	170
9.5	1478	3.0	150	34500				VFR 210_150	P100	BE100LA4	BX100LA4	178
9.6	1326	1.5	100	19000				VF 185_100	P112	BE112M6		168
10.3	1360	1.0	138	13800				VFR 130_138	P100	BE100LA4	BX100LA4	154
10.3	1379	1.4	138	16000				VFR 150_138	P100	BE100LA4	BX100LA4	162
10.6	1404	2.3	90	19500				VFR 185_90	P112	BE112M6		170
10.6	1385	3.3	90	34500				VFR 210_90	P112	BE112M6		178
11.9	1111	1.3	80	15500				VF 150_80	P112	BE112M6		160
11.9	1129	2.1	80	19000				VF 185_80	P112	BE112M6		168
12.0	1182	1.2	120	13800				VFR 130_120	P100	BE100LA4	BX100LA4	154
12.0	1200	1.6	120	16000				VFR 150_120	P100	BE100LA4	BX100LA4	162
12.0	1235	2.9	120	19500				VFR 185_120	P100	BE100LA4	BX100LA4	170
12.0	1235	4.1	120	34500				VFR 210_120	P100	BE100LA4	BX100LA4	178
13.8	1091	1.4	69	13800				VFR 130_69	P112	BE112M6		154
13.8	1091	1.9	69	16000				VFR 150_69	P112	BE112M6		162
14.3	956	1.2	100	14700				VF 150_100	P100	BE100LA4	BX100LA4	160
14.3	956	2.0	100	18000				VF 185_100	P100	BE100LA4	BX100LA4	168
14.9	931	1.2	64	13200				VF 130_64	P112	BE112M6		152
15.9	939	1.6	90	13800				VFR 130_90	P100	BE100LA4	BX100LA4	154
15.9	953	2.0	90	16000				VFR 150_90	P100	BE100LA4	BX100LA4	162
15.9	911	2.8	60	19000				VF 185_60	P112	BE112M6		168
15.9	1005	2.7	90	19500				VFR 185_90	P100	BE100LA4	BX100LA4	170
17.1	838	1.3	56	13200				VF 130_56	P112	BE112M6		152
17.8	800	1.1	80	12600				VF 130_80	P100	BE100LA4	BX100LA4	152
17.8	812	1.5	80	14700				VF 150_80	P100	BE100LA4	BX100LA4	160



2.2 kW







n ₂ min-1	M ₂ Nm	S	i	R _{n2} N										
					IE2	IE3		IE2	IE3					
17.8	812	2.6	80	18000				VF 185_80	P100	BE100LA4	BX100LA4	168		
20.7	771	1.7	69	13800				VFR 130_69	P100	BE100LA4	BX100LA4	154		
20.7	781	2.3	69	16000				VFR 150_69	P100	BE100LA4	BX100LA4	162		
20.8	718	1.6	46	13200				VF 130_46	P112	BE112M6		152		
20.8	728	2.4	46	15500				VF 150_46	P112	BE112M6		160		
21.2	762	1.1	45	8000				WR 110_45	P112	BE112M6		150		
22.3	668	1.4	64	12600				VF 130_64	P100	BE100LA4	BX100LA4	152		
22.3	678	1.9	64	14700				VF 150_64	P100	BE100LA4	BX100LA4	160		
23.8	697	1.0	60	8000				WR 110_60	P100	BE100LA4	BX100LA4	150		
23.8	688	1.9	60	13800				VFR 130_60	P100	BE100LA4	BX100LA4	154		
23.8	697	2.7	60	16000				VFR 150_60	P100	BE100LA4	BX100LA4	162		
23.8	653	3.4	60	18000				VF 185_60	P100	BE100LA4	BX100LA4	168		
23.9	631	1.2	40	8000				W 110_40	P112	BE112M6	BE112M6	149		
25.6	593	1.0	56	8000	W110_56	S3	ME3LA4	MX3LA4	148	W 110_56	P100	BE100LA4	BX100LA4	149
25.6	601	1.6	56	12600				VF 130_56	P100	BE100LA4	BX100LA4	152		
25.6	609	2.2	56	14200				VF 150_56	P100	BE100LA4	BX100LA4	160		
31	500	1.2	46	8000	W110_46	S3	ME3LA4	MX3LA4	148	W 110_46	P100	BE100LA4	BX100LA4	149
31	514	2.0	46	12600				VF 130_46	P100	BE100LA4	BX100LA4	152		
31	521	2.9	46	14700				VF 150_46	P100	BE100LA4	BX100LA4	160		
32	529	1.3	45	8000				WR 110_45	P100	BE100LA4	BX100LA4	150		
31	543	3.1	45	16000				VFR 150_45	P100	BE100LA4	BX100LA4	162		
35	447	1.5	40	8000	W110_40	S3	ME3LA4	MX3LA4	148	W 110_40	P100	BE100LA4	BX100LA4	149
35	447	2.4	40	12600				VF 130_40	P100	BE100LA4	BX100LA4	152		
35	453	3.4	40	14700				VF 150_40	P100	BE100LA4	BX100LA4	160		
42	398	2.6	23	13200				VF 130_23	P112	BE112M6		152		
48	335	1.1	30	7000	W86_30	S3	ME3LA4	MX3LA4	144	W 86_30	P100	BE100LA4	BX100LA4	145
48	339	2.1	30	8000	W110_30	S3	ME3LA4	MX3LA4	148	W 110_30	P100	BE100LA4	BX100LA4	149
48	348	3.0	30	12600				VF 130_30	P100	BE100LA4	BX100LA4	152		
62	277	1.2	23	6990	W86_23	S3	ME3LA4	MX3LA4	144	W 86_23	P100	BE100LA4	BX100LA4	145
62	280	1.9	23	8000	W110_23	S3	ME3LA4	MX3LA4	148	W 110_23	P100	BE100LA4	BX100LA4	149
62	280	3.1	23	12600				VF 130_23	P100	BE100LA4	BX100LA4	152		
72	244	1.0	20	3410	W75_20	S3	ME3LA4	MX3LA4	140	W 75_20	P100	BE100LA4	BX100LA4	141
72	247	1.3	20	6730	W86_20	S3	ME3LA4	MX3LA4	144	W 86_20	P100	BE100LA4	BX100LA4	145
72	247	2.3	20	8000	W110_20	S3	ME3LA4	MX3LA4	148	W 110_20	P100	BE100LA4	BX100LA4	149
95	187	1.3	15	3240	W75_15	S3	ME3LA4	MX3LA4	140	W 75_15	P100	BE100LA4	BX100LA4	141
95	187	1.8	15	6270	W86_15	S3	ME3LA4	MX3LA4	144	W 86_15	P100	BE100LA4	BX100LA4	145
95	185	3.2	15	8000	W110_15	S3	ME3LA4	MX3LA4	148	W 110_15	P100	BE100LA4	BX100LA4	149
136	133	1.6	7	2780				W 75_7	P112	BE112M6		141		
136	133	2.0	7	5540				W 86_7	P112	BE112M6		145		
143	129	1.8	10	2940	W75_10	S3	ME3LA4	MX3LA4	140	W 75_10	P100	BE100LA4	BX100LA4	141
143	129	2.2	10	5590	W86_10	S3	ME3LA4	MX3LA4	144	W 86_10	P100	BE100LA4	BX100LA4	145
191	98	2.3	15	2920	W75_15	S3	ME3LA2		140	W 75_15	P90	BE90L2		141
191	93	1.3	15	1980				W 63_15	P90	BE90L2		138		
204	93	2.1	7	2660	W75_7	S3	ME3LA4	MX3LA4	140	W 75_7	P100	BE100LA4	BX100LA4	141
204	92	2.7	7	5030	W86_7	S3	ME3LA4	MX3LA4	144	W 86_7	P100	BE100LA4	BX100LA4	145
239	75	1.6	12	1890				W 63_12	P90	BE90L2		138		
287	66	3.0	10	2610	W75_10	S3	ME3LA2		140	W 75_10	P90	BE90L2		141
287	63	1.9	10	1820				W 63_10	P90	BE90L2		138		
409	48	3.6	7	2350	W75_7	S3	ME3LA2		140	W 75_7	P90	BE90L2		141
409	46	2.3	7	1660				W 63_7	P90	BE90L2		138		

3 kW

n ₂ min-1	M ₂ Nm	S	i	R _{n2} N								
					IE2	IE3		IE2	IE3			
0.90	10403	0.9	1600	52000				VF/VF 130/250_1600	P100	BE100LB4	BX100LB4	186
1.0	9813	0.9	920	52000				VF/VF 130/250_920	P132	BE132S6		186
1.2	8534	1.1	1200	52000				VF/VF 130/250_1200	P100	BE100LB4	BX100LB4	186
1.5	6917	0.9	920	34500				VF/VF 130/210_920	P100	BE100LB4	BX100LB4	180
1.5	6917	1.3	920	52000				VF/VF 130/250_920	P100	BE100LB4	BX100LB4	186









3 kW







n ₂ min ⁻¹	M ₂ Nm	S	i	R _{n2} N	 			 						
					IE2	IE3		IE2	IE3					
1.8	6665	0.9	800	34500				VF/VF 130/210_800	P100	BE100LB4	BX100LB4	180		
1.8	6827	1.3	800	52000				VF/VF 130/250_800	P100	BE100LB4	BX100LB4	186		
2.5	5242	1.2	600	34500				VF/VF 130/210_600	P100	BE100LB4	BX100LB4	180		
2.5	5364	1.7	600	52000				VF/VF 130/250_600	P100	BE100LB4	BX100LB4	186		
3.2	4755	1.1	300	52000				VFR 250_300	P132	BE132S6		184		
3.6	3901	1.1	400	19500				W /VF 86/185_400	P100	BE100LB4	BX100LB4	174		
3.6	4064	1.6	400	34500				VF/VF 130/210_400	P100	BE100LB4	BX100LB4	180		
3.6	3983	2.3	400	52000				VF/VF 130/250_400	P100	BE100LB4	BX100LB4	186		
4.0	3950	1.1	240	34500				VFR 210_240	P132	BE132S6		178		
4.0	4096	1.4	240	52000				VFR 250_240	P132	BE132S6		184		
4.8	3353	1.0	300	34500				VFR 210_300	P100	BE100LB4	BX100LB4	178		
4.8	3475	1.4	300	52000				VFR 250_300	P100	BE100LB4	BX100LB4	184		
5.1	2958	1.4	280	19500				W /VF 86/185_280	P100	BE100LB4	BX100LB4	174		
5.1	2958	2.1	280	34500				VF/VF 130/210_280	P100	BE100LB4	BX100LB4	180		
5.1	3015	3.0	280	52000				VF/VF 130/250_280	P100	BE100LB4	BX100LB4	186		
6.0	2877	1.0	240	19500				VFR 185_240	P100	BE100LB4	BX100LB4	170		
6.0	2877	1.4	240	34500				VFR 210_240	P100	BE100LB4	BX100LB4	178		
6.0	2975	1.8	240	52000				VFR 250_240	P100	BE100LB4	BX100LB4	184		
8.0	2377	1.3	180	19500				VFR 185_180	P100	BE100LB4	BX100LB4	170		
8.0	2341	1.8	180	34500				VFR 210_180	P100	BE100LB4	BX100LB4	178		
8.0	2450	2.6	180	52000				VFR 250_180	P100	BE100LB4	BX100LB4	184		
9.6	2042	1.6	150	19500				VFR 185_150	P100	BE100LB4	BX100LB4	170		
9.6	1859	1.6	100	33000				VF 210_100	P132	BE132S6		176		
9.6	2042	2.2	150	34500				VFR 210_150	P100	BE100LB4	BX100LB4	178		
9.6	1920	2.5	100	50000				VF 250_100	P132	BE132S6		182		
9.6	2042	3.2	150	52000				VFR 250_150	P100	BE100LB4	BX100LB4	184		
10.4	1907	1.0	138	16000				VFR 150_138	P100	BE100LB4	BX100LB4	162		
11.9	1609	1.5	80	19000				VF 185_80	P132	BE132S6		168		
11.9	1585	2.1	80	33000				VF 210_80	P132	BE132S6		176		
12.1	1634	0.9	120	13800				VFR 130_120	P100	BE100LB4	BX100LB4	154		
12.1	1658	1.2	120	16000				VFR 150_120	P100	BE100LB4	BX100LB4	162		
12.1	1707	2.1	120	19500				VFR 185_120	P100	BE100LB4	BX100LB4	170		
12.1	1707	2.9	120	34500				VFR 210_120	P100	BE100LB4	BX100LB4	178		
12.1	1731	4.0	120	52000				VFR 250_120	P100	BE100LB4	BX100LB4	184		
14.4	1321	0.9	100	14700				VF 150_100	P100	BE100LB4	BX100LB4	160		
14.4	1321	1.4	100	18000				VF 185_100	P100	BE100LB4	BX100LB4	168		
15.9	1298	2.0	60	19000				VF 185_60	P132	BE132S6		168		
15.9	1280	2.9	60	33000				VF 210_60	P132	BE132S6		176		
16.0	1298	1.2	90	13800				VFR 130_90	P100	BE100LB4	BX100LB4	154		
16.0	1317	1.5	90	16000				VFR 150_90	P100	BE100LB4	BX100LB4	162		
16.0	1390	2.0	90	19500				VFR 185_90	P100	BE100LB4	BX100LB4	170		
16.0	1390	2.9	90	34500				VFR 210_90	P100	BE100LB4	BX100LB4	178		
18.0	1122	1.1	80	14700				VF 150_80	P100	BE100LB4	BX100LB4	160		
18.0	1122	1.9	80	18000				VF 185_80	P100	BE100LB4	BX100LB4	168		
20.8	1066	1.2	69	13800				VFR 130_69	P100	BE100LB4	BX100LB4	154		
20.8	1080	1.7	69	16000				VFR 150_69	P100	BE100LB4	BX100LB4	162		
22.5	923	1.0	64	12600				VF 130_64	P100	BE100LB4	BX100LB4	152		
22.5	936	1.4	64	14700				VF 150_64	P100	BE100LB4	BX100LB4	160		
24.0	951	1.4	60	13800				VFR 130_60	P100	BE100LB4	BX100LB4	154		
24.0	963	2.0	60	16000				VFR 150_60	P100	BE100LB4	BX100LB4	162		
24.0	902	2.5	60	18000				VF 185_60	P100	BE100LB4	BX100LB4	168		
25.7	831	1.2	56	12600				VF 130_56	P100	BE100LB4	BX100LB4	152		
25.7	842	1.6	56	14700				VF 150_56	P100	BE100LB4	BX100LB4	160		
28.8	772	3.2	50	18000				VF 185_50	P100	BE100LB4	BX100LB4	168		
32	710	1.5	46	12600				VF 130_46	P100	BE100LB4	BX100LB4	152		
32	720	2.2	46	14700				VF 150_46	P100	BE100LB4	BX100LB4	160		
32	720	1.0	45	8000				WR 110_45	P100	BE100LB4	BX100LB4	150		
32	750	2.3	45	16000				VFR 150_45	P100	BE100LB4	BX100LB4	162		
36	608	1.1	40	8000	W110_40	S3	ME3LB4	MX3LB4	148	W 110_40	P100	BE100LB4	BX100LB4	149
36	618	1.8	40	12600				VF 130_40	P100	BE100LB4	BX100LB4	152		
36	626	2.5	40	14700				VF 150_40	P100	BE100LB4	BX100LB4	160		
42	568	1.0	23	8000				W 110_23	P132	BE132S6		149		
42	568	1.8	23	13200				VF 130_23	P132	BE132S6		152		



3 kW

n ₂ min-1	M ₂ Nm	S	i	R _{n2} N	 			 						
					IE2	IE3		IE2	IE3					
48	462	1.5	30	8000	W110_30	S3	ME3LB4	MX3LB4	148	W 110_30	P100	BE100LB4	BX100LB4	149
48	482	2.2	30	12600						VF 130_30	P100	BE100LB4	BX100LB4	152
48	488	2.8	30	14700						VF 150_30	P100	BE100LB4	BX100LB4	160
48	518	2.9	30	16000						VFR 150_30	P100	BE100LB4	BX100LB4	162
62	382	1.4	23	8000	W110_23	S3	ME3LB4	MX3LB4	148	W 110_23	P100	BE100LB4	BX100LB4	149
62	388	2.3	23	12600						VF 130_23	P100	BE100LB4	BX100LB4	152
62	388	3.3	23	14700						VF 150_23	P100	BE100LB4	BX100LB4	160
72	336	1.0	20	6240	W86_20	S3	ME3LB4	MX3LB4	144	W 86_20	P100	BE100LB4	BX100LB4	145
72	336	1.7	20	8000	W110_20	S3	ME3LB4	MX3LB4	148	W 110_20	P100	BE100LB4	BX100LB4	149
73	341	2.6	20	12600						VF 130_20	P100	BE100LB4	BX100LB4	152
96	259	1.0	15	2800	W75_15	S3	ME3LB4	MX3LB4	140	W 75_15	P100	BE100LB4	BX100LB4	141
96	259	1.3	15	5890	W86_15	S3	ME3LB4	MX3LB4	144	W 86_15	P100	BE100LB4	BX100LB4	145
96	256	2.4	15	8000	W110_15	S3	ME3LB4	MX3LB4	148	W 110_15	P100	BE100LB4	BX100LB4	149
96	262	3.5	15	11800						VF 130_15	P100	BE100LB4	BX100LB4	152
125	197	3.4	23	11000						VF 130_23	P100	BE100L2		152
144	179	1.3	10	2600	W75_10	S3	ME3LB4	MX3LB4	140	W 75_10	P100	BE100LB4	BX100LB4	141
144	179	1.6	10	5300	W86_10	S3	ME3LB4	MX3LB4	144	W 86_10	P100	BE100LB4	BX100LB4	145
144	177	3.1	10	8000	W110_10	S3	ME3LB4	MX3LB4	148	W 110_10	P100	BE100LB4	BX100LB4	149
192	131	1.7	15	2680	W75_15	S3	ME3LB2		140	W 75_15	P100	BE100L2		141
192	130	2.3	15	5070	W86_15	S3	ME3LB2		144	W 86_15	P100	BE100L2		145
206	128	1.5	7	2380	W75_7	S3	ME3LB4	MX3LB4	140	W 75_7	P100	BE100LB4	BX100LB4	141
206	127	2.0	7	4780	W86_7	S3	ME3LB4	MX3LB4	144	W 86_7	P100	BE100LB4	BX100LB4	145
288	90	2.3	10	2430	W75_10	S3	ME3LB2		140	W 75_10	P100	BE100L2		141
288	90	2.9	10	4510	W86_10	S3	ME3LB2		144	W 86_10	P100	BE100L2		145
411	64	2.7	7	2190	W75_7	S3	ME3LB2		140	W 75_7	P100	BE100L2		141
411	64	3.5	7	4040	W86_7	S3	ME3LB2		144	W 86_7	P100	BE100L2		145

4 kW

n ₂ min-1	M ₂ Nm	S	i	R _{n2} N	 			 				
					IE2	IE3		IE2	IE2			
1.5	9157	1.0	920	52000				VF/VF 130/250_920	P112	BE112M4	BX112M4	186
1.9	9039	1.0	800	52000				VF/VF 130/250_800	P112	BE112M4	BX112M4	186
2.5	6941	0.9	600	34500				VF/VF 130/210_600	P112	BE112M4	BX112M4	180
2.5	7102	1.3	600	52000				VF/VF 130/250_600	P112	BE112M4	BX112M4	186
3.7	5380	1.2	400	34500				VF/VF 130/210_400	P112	BE112M4	BX112M4	180
3.7	5273	1.7	400	52000				VF/VF 130/250_400	P112	BE112M4	BX112M4	186
4.0	5348	1.1	240	52000				VFR 250_240	P132	BE132MA6		184
4.8	4600	1.1	300	52000				VFR 250_300	P112	BE112M4	BX112M4	184
5.2	3917	1.1	280	19500				W /VF 86/185_280	P112	BE112M4	BX112M4	174
5.2	3917	1.6	280	34500				VF/VF 130/210_280	P112	BE112M4	BX112M4	180
5.2	3992	2.3	280	52000				VF/VF 130/250_280	P112	BE112M4	BX112M4	186
5.4	3867	1.3	180	34500				VFR 210_180	P132	BE132MA6		178
5.4	4440	1.5	180	52000				VFR 250_180	P132	BE132MA6		184
6.1	3809	1.0	240	34500				VFR 210_240	P112	BE112M4	BX112M4	178
6.1	3938	1.4	240	52000				VFR 250_240	P112	BE112M4	BX112M4	184
8.1	3147	1.0	180	19500				VFR 185_180	P112	BE112M4	BX112M4	170
8.1	3099	1.4	180	34500				VFR 210_180	P112	BE112M4	BX112M4	178
8.1	3244	1.9	180	52000				VFR 250_180	P112	BE112M4	BX112M4	184
9.7	2427	1.2	100	33000				VF 210_100	P132	BE132MA6		176
9.7	2507	1.9	100	50000				VF 250_100	P132	BE132MA6		182
9.8	2704	1.2	150	19500				VFR 185_150	P112	BE112M4	BX112M4	170
9.8	2704	1.7	150	34500				VFR 210_150	P112	BE112M4	BX112M4	178
9.8	2704	2.4	150	52000				VFR 250_150	P112	BE112M4	BX112M4	184
12.1	2195	0.9	120	16000				VFR 150_120	P112	BE112M4	BX112M4	162
12.1	2260	1.6	120	19500				VFR 185_120	P112	BE112M4	BX112M4	170
12.1	2260	2.2	120	34500				VFR 210_120	P112	BE112M4	BX112M4	178
12.1	2292	3.1	120	52000				VFR 250_120	P112	BE112M4	BX112M4	184
14.6	1749	1.1	100	18000				VF 185_100	P112	BE112M4	BX112M4	168
16.1	1695	1.5	60	19000				VF 185_60	P132	BE132MA6		168
16.1	1671	2.2	60	33000				VF 210_60	P132	BE132MA6		176









4 kW

n ₂ min ⁻¹	M ₂ Nm	S	i	Rn ₂ N							
					IE2	IE3		IE2	IE2		
16.1	1719	3.2	60	50000				VF 250_60	P132	BE132MA6	182
16.3	1719	0.9	90	13800				VFR 130_90	P112	BE112M4 BX112M4	154
16.3	1743	1.1	90	16000				VFR 150_90	P112	BE112M4 BX112M4	162
16.3	1840	1.5	90	19500				VFR 185_90	P112	BE112M4 BX112M4	170
16.3	1840	2.2	90	34500				VFR 210_90	P112	BE112M4 BX112M4	178
16.3	1888	3.2	90	52000				VFR 250_90	P112	BE112M4 BX112M4	184
18.3	1485	1.4	80	18000				VF 185_80	P112	BE112M4 BX112M4	168
21.0	1355	1.3	46	15500				VF 150_46	P132	BE132MA6	160
21.2	1411	0.9	69	13800				VFR 130_69	P112	BE112M4 BX112M4	154
21.2	1429	1.3	69	16000				VFR 150_69	P112	BE112M4 BX112M4	162
21.4	1433	3.4	45	34500				VFR 210_45	P132	BE132MA6	178
22.8	1240	1.1	64	14700				VF 150_64	P112	BE112M4 BX112M4	160
24.1	1162	1.0	40	13200				VF 130_40	P132	BE132MA6	152
24.1	1193	3.6	40	33000				VF 210_40	P132	BE132MA6	176
24.4	1259	1.1	60	13800				VFR 130_60	P112	BE112M4 BX112M4	154
24.4	1275	1.5	60	16000				VFR 150_60	P112	BE112M4 BX112M4	162
24.4	1194	1.9	60	18000				VF 185_60	P112	BE112M4 BX112M4	168
24.4	1307	2.5	60	19500				VFR 185_60	P112	BE112M4 BX112M4	170
24.4	1291	3.6	60	34500				VFR 210_60	P112	BE112M4 BX112M4	178
26.1	1100	0.9	56	12500				VF 130_56	P112	BE112M4 BX112M4	152
26.1	1115	1.2	56	14700				VF 150_56	P112	BE112M4 BX112M4	160
29.2	1022	2.4	50	18000				VF 185_50	P112	BE112M4 BX112M4	168
32	940	1.1	46	12600				VF 130_46	P112	BE112M4 BX112M4	152
32	953	1.6	46	14700				VF 150_46	P112	BE112M4 BX112M4	160
32	967	2.5	30	19000				VF 185_30	P132	BE132MA6	168
32	955	3.5	30	33000				VF 210_30	P132	BE132MA6	176
33	993	1.7	45	16000				VFR 150_45	P112	BE112M4 BX112M4	162
33	1017	2.8	45	19500				VFR 185_45	P112	BE112M4 BX112M4	170
36	762	0.9	80	12600				VF 130_80	P112	BE112M2	152
37	818	1.3	40	12600				VF 130_40	P112	BE112M4 BX112M4	152
37	829	1.9	40	14700				VF 150_40	P112	BE112M4 BX112M4	160
42	741	1.4	23	13200				VF 130_23	P132	BE132MA6	152
42	750	2.0	23	13200				VF 150_23	P132	BE132MA6	160
45	635	1.1	64	12600				VF 130_64	P112	BE112M2	152
48	624	1.1	30	8000				W 110_30	P112	BE112M4 BX112M4	149
48	638	1.6	30	12600				VF 130_30	P112	BE112M4 BX112M4	152
48	646	2.1	30	14700				VF 150_30	P112	BE112M4 BX112M4	160
48	686	2.2	30	16000				VFR 150_30	P112	BE112M4 BX112M4	162
63	515	1.0	23	8000				W 110_23	P112	BE112M4 BX112M4	149
63	480	1.6	46	12600				VF 130_46	P112	BE112M2	152
64	514	1.7	23	12600				VF 130_23	P112	BE112M4 BX112M4	152
64	514	2.5	23	14700				VF 150_23	P112	BE112M4 BX112M4	160
72	454	1.3	20	8000				W 110_20	P112	BE112M4 BX112M4	149
73	452	2.0	20	12400				VF 130_20	P112	BE112M4 BX112M4	152
96	344	1.0	15	5410				W 86_15	P112	BE112M4 BX112M4	145
96	340	1.8	15	8000				W 110_15	P112	BE112M4 BX112M4	149
97	346	3.4	10	12700				VF 150_10	P132	BE132MA6	160
98	347	2.7	15	11400				VF 130_15	P112	BE112M4 BX112M4	152
144	238	1.0	10	2160				W 75_10	P112	BE112M4 BX112M4	141
144	238	1.2	10	4940				W 86_10	P112	BE112M4 BX112M4	145
144	235	2.3	10	7840				W 110_10	P112	BE112M4 BX112M4	149
146	237	3.3	10	10100				VF 130_10	P112	BE112M4 BX112M4	152
193	174	1.3	15	2400				W 75_15	P112	BE112M2	141
193	172	1.7	15	4820				W 86_15	P112	BE112M2	145
206	173	1.1	7	1900				W 75_7	P112	BE112M4 BX112M4	141
206	171	1.5	7	4490				W 86_7	P112	BE112M4 BX112M4	145
206	171	3.0	7	7040				W 110_7	P112	BE112M4 BX112M4	149
290	119	1.7	10	2210				W 75_10	P112	BE112M2	141
290	119	2.2	10	4320				W 86_10	P112	BE112M2	145
414	84	2.0	7	2010				W 75_7	P112	BE112M2	141
414	84	2.7	7	3890				W 86_7	P112	BE112M2	145





5.5 kW

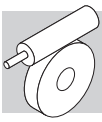

n ₂ min-1	M ₂ Nm	S	i	R _{n2} N	 			 				
					IE2	IE3		IE2	IE3			
2.4	9630	0.9	600	52000				VF/VF 130/250_600	P132	BE132S4	BX132S4	186
3.4	7714	1.2	280	52000				VF/VF 130/250_280	P160	BE160MA6		186
3.7	7295	0.9	400	34500				VF/VF 130/210_400	P132	BE132S4	BX132S4	180
3.7	7149	1.3	400	52000				VF/VF 130/250_400	P132	BE132S4	BX132S4	186
5.2	5311	1.2	280	34500				VF/VF 130/210_280	P132	BE132S4	BX132S4	180
5.2	5413	1.7	280	52000				VF/VF 130/250_280	P132	BE132S4	BX132S4	186
5.4	6029	1.1	180	52000				VFR 250_180	P160	BE160MA6		184
6.4	5024	1.0	150	34500				VFR 210_150	P160	BE160MA6		178
6.4	5105	1.3	150	52000				VFR 250_150	P160	BE160MA6		184
8.1	4202	1.0	180	34500				VFR 210_180	P132	BE132S4	BX132S4	178
8.1	4399	1.4	180	52000				VFR 250_180	P132	BE132S4	BX132S4	184
9.7	3296	0.9	100	33000				VF 210_100	P160	BE160MA6		176
9.7	3666	1.2	150	34500				VFR 210_150	P132	BE132S4	BX132S4	178
9.7	3666	1.8	150	52000				VFR 250_150	P132	BE132S4	BX132S4	184
12.1	2809	1.1	80	33000				VF 210_80	P160	BE160MA6		176
12.1	2895	1.7	80	50000				VF 250_80	P160	BE160MA6		182
12.2	3064	1.6	120	34500				VFR 210_120	P132	BE132S4	BX132S4	178
12.2	3108	2.3	120	52000				VFR 250_120	P132	BE132S4	BX132S4	184
14.6	2371	1.1	100	31500				VF 210_100	P132	BE132S4	BX132S4	176
14.6	2590	1.4	100	19500				VFR 185_100	P132	BE132S4	BX132S4	170
14.6	2480	1.5	100	47000				VF 250_100	P132	BE132S4	BX132S4	182
16.1	2301	1.1	60	19000				VF 185_60	P160	BE160MA6		168
16.1	2268	1.6	60	33000				VF 210_60	P160	BE160MA6		176
16.1	2334	2.4	60	50000				VF 250_60	P160	BE160MA6		182
16.2	2495	1.6	90	34500				VFR 210_90	P132	BE132S4	BX132S4	178
16.2	2561	2.3	90	52000				VFR 250_90	P132	BE132S4	BX132S4	184
18.3	2013	1.1	80	18000				VF 185_80	P132	BE132S4	BX132S4	168
18.3	2013	1.4	80	31500				VF 210_80	P132	BE132S4	BX132S4	176
18.3	2072	1.9	80	47000				VF 250_80	P132	BE132S4	BX132S4	182
19.5	2106	1.3	75	19500				VFR 185_75	P132	BE132S4	BX132S4	170
21.0	1839	0.9	46	15500				VF 150_46	P160	BE160MA6		160
21.4	1945	2.5	45	34500				VFR 210_45	P160	BE160MA6		178
21.4	1993	3.4	45	52000				VFR 250_45	P160	BE160MA6		184
24.1	1599	1.1	40	15500				VF 150_40	P160	BE160MA6		160
24.3	1620	1.4	60	18000				VF 185_60	P132	BE132S4	BX132S4	168
24.3	1598	1.9	60	31500				VF 210_60	P132	BE132S4	BX132S4	176
24.3	1751	2.7	60	34500				VFR 210_60	P132	BE132S4	BX132S4	178
24.3	1663	2.7	60	47000				VF 250_60	P132	BE132S4	BX132S4	182
24.3	1773	4.0	60	52000				VFR 250_60	P132	BE132S4	BX132S4	184
29.2	1430	1.3	50	15940				VFR 150_50	P132	BE132S4	BX132S4	162
29.2	1386	1.8	50	18000				VF 185_50	P132	BE132S4	BX132S4	168
29.2	1477	2.2	50	19500				VFR 185_50	P132	BE132S4	BX132S4	170
29.2	1386	2.4	50	31500				VF 210_50	P132	BE132S4	BX132S4	176
29.2	1386	3.2	50	47000				VF 250_50	P132	BE132S4	BX132S4	182
31	1292	1.2	46	14700				VF 150_46	P132	BE132S4	BX132S4	160
32	1248	1.0	30	13200				VF 130_30	P160	BE160MA6		152
32	1362	3.0	45	34500				VFR 210_45	P132	BE132S4	BX132S4	178
37	1109	1.0	40	12600				VF 130_40	P132	BE132S4	BX132S4	152
37	1123	1.4	40	14700				VF 150_40	P132	BE132S4	BX132S4	160
37	1138	2.3	40	18000				VF 185_40	P132	BE132S4	BX132S4	168
37	1138	3.1	40	31500				VF 210_40	P132	BE132S4	BX132S4	176
39	1101	1.5	38	15400				VFR 150_37.5	P132	BE132S4	BX132S4	162
39	1149	2.4	38	19500				VFR 185_37.5	P132	BE132S4	BX132S4	170
42	1006	1.0	23	13000				VF 130_23	P160	BE160MA6		152
42	1019	1.4	23	15300				VF 150_23	P160	BE160MA6		160
49	864	1.2	30	12600				VF 130_30	P132	BE132S4	BX132S4	152
49	875	1.6	30	14700				VF 150_30	P132	BE132S4	BX132S4	160
49	908	2.2	30	18000				VF 185_30	P132	BE132S4	BX132S4	168
49	908	3.4	30	31500				VF 210_30	P132	BE132S4	BX132S4	176
59	775	1.9	25	13400				VFR 150_25	P132	BE132S4	BX132S4	162
59	784	3.3	25	19500				VFR 185_25	P132	BE132S4	BX132S4	170
64	673	0.9	15	8000				W 110_15	P160	BE160MA6		149
64	696	1.3	23	12100				VF 130_23	P132	BE132S4	BX132S4	152
64	696	1.8	23	14000				VF 150_23	P132	BE132S4	BX132S4	160
73	605	0.9	20	8000				W 110_20	P132	BE132S4	BX132S4	149



5.5 kW

n ₂ min-1	M ₂ Nm	S	i	R _{n2} N	 						
					IE2	IE3	IE2	IE3	IE2	IE3	
73	613	1.5	20	11700			VF 130_20	P132	BE132S4	BX132S4	152
73	613	2.1	20	13500			VF 150_20	P132	BE132S4	BX132S4	160
97	454	1.3	15	8000			W 110_15	P132	BE132S4	BX132S4	149
97	471	2.0	15	12800			VF 130_15	P132	BE132S4	BX132S4	152
97	476	2.4	15	12400			VF 150_15	P132	BE132S4	BX132S4	160
127	354	1.9	23	10400			VF 130_23	P132	BE132SA2		152
127	354	2.7	23	11800			VF 150_23	P132	BE132SA2		160
146	313	1.8	10	7330			W 110_10	P132	BE132S4	BX132S4	149
146	321	2.5	10	9680			VF 130_10	P132	BE132S4	BX132S4	152
146	321	3.3	10	11000			VF 150_10	P132	BE132S4	BX132S4	160
195	234	2.3	15	7060			W 110_15	P132	BE132SA2		149
209	227	2.2	7	6600			W 110_7	P132	BE132S4	BX132S4	149
209	227	3.3	7	8650			VF 130_7	P132	BE132S4	BX132S4	152
293	160	3.0	10	6290			W 110_10	P132	BE132SA2		149
293	162	3.6	10	8110			VF 130_10	P132	BE132SA2		152
418	113	4.0	7	5640			W 110_7	P132	BE132SA2		149
418	114	4.9	7	7230			VF 130_7	P132	BE132SA2		152

7.5 kW

n ₂ min-1	M ₂ Nm	S	i	R _{n2} N	 						
					IE2	IE3	IE2	IE2	IE2	IE2	
3.6	9554	0.9	400	52000			VF/VF 130/250_400	P132	BE132MA4	BX132MA4	186
5.2	7097	0.9	280	34500			VF/VF 130/210_280	P132	BE132MA4	BX132MA4	180
5.2	7233	1.2	280	52000			VF/VF 130/250_280	P132	BE132MA4	BX132MA4	186
6.4	7014	1.0	150	52000			VFR 250_150	P160	BE160MB6		184
8.0	5878	1.0	120	34500			VFR 210_120	P160	BE160MB6		178
8.1	5879	1.1	180	52000			VFR 250_180	P132	BE132MA4	BX132MA4	184
9.7	4676	1.0	100	50000			VF 250_100	P160	BE160MB6		182
9.7	4899	1.3	150	52000			VFR 250_150	P132	BE132MA4	BX132MA4	184
10.7	4809	0.9	90	34500			VFR 210_90	P160	BE160MB6		178
12.1	3978	1.3	80	50000			VF 250_80	P160	BE160MB6		182
12.1	4094	1.2	120	34500			VFR 210_120	P132	BE132MA4	BX132MA4	178
12.1	4153	1.7	120	52000			VFR 250_120	P132	BE132MA4	BX132MA4	184
14.6	3461	1.0	100	19500			VFR 185_100	P132	BE132MA4	BX132MA4	170
14.6	3314	1.1	100	47000			VF 250_100	P132	BE132MA4	BX132MA4	182
16.1	3117	1.2	60	33000			VF 210_60	P160	BE160MB6		176
16.2	3334	1.2	90	34500			VFR 210_90	P132	BE132MA4	BX132MA4	178
16.2	3422	1.7	90	52000			VFR 250_90	P132	BE132MA4	BX132MA4	184
18.2	2691	1.1	80	31500			VF 210_80	P132	BE132MA4	BX132MA4	176
18.2	2769	1.4	80	47000			VF 250_80	P132	BE132MA4	BX132MA4	182
19.4	2815	1.0	75	19500			VFR 185_75	P132	BE132MA4	BX132MA4	170
21.4	2672	1.8	45	34500			VFR 210_45	P160	BE160MB6		178
21.4	2739	2.5	45	52000			VFR 250_45	P160	BE160MB6		184
24.3	2164	1.0	60	18000			VF 185_60	P132	BE132MA4	BX132MA4	168
24.3	2135	1.4	60	31500			VF 210_60	P132	BE132MA4	BX132MA4	176
24.3	2340	2.0	60	31500			VFR 210_60	P132	BE132MA4	BX132MA4	178
24.3	2223	2.0	60	47000			VF 250_60	P132	BE132MA4	BX132MA4	182
24.3	2369	3.0	60	52000			VFR 250_60	P132	BE132MA4	BX132MA4	184
29.1	1911	1.0	50	14100			VFR 150_50	P132	BE132MA4	BX132MA4	162
29.1	1852	1.3	50	18000			VF 185_50	P132	BE132MA4	BX132MA4	168
29.1	1974	1.6	50	19500			VFR 185_50	P132	BE132MA4	BX132MA4	170
29.1	1852	1.7	50	31500			VF 210_50	P132	BE132MA4	BX132MA4	176
29.1	1852	2.4	50	47000			VF 250_50	P132	BE132MA4	BX132MA4	182
31	1727	0.9	46	14700			VF 150_46	P132	BE132MA4	BX132MA4	160
32	1821	2.2	45	34500			VFR 210_45	P132	BE132MA4	BX132MA4	178
32	1842	3.5	45	48800			VFR 250_45	P132	BE132MA4	BX132MA4	184
36	1501	1.0	40	14700			VF 150_40	P132	BE132MA4	BX132MA4	160
36	1521	1.7	40	18000			VF 185_40	P132	BE132MA4	BX132MA4	168
36	1521	2.3	40	31500			VF 210_40	P132	BE132MA4	BX132MA4	176
36	1541	3.2	40	47000			VF 250_40	P132	BE132MA4	BX132MA4	182
38	1471	1.1	38	13200			VFR 150_37.5	P132	BE132MA4	BX132MA4	162
38	1536	1.8	38	18300			VFR 185_37.5	P132	BE132MA4	BX132MA4	170
49	1155	0.9	30	11900			VF 130_30	P132	BE132MA4	BX132MA4	152
49	1170	1.1	30	14200			VF 150_30	P132	BE132MA4	BX132MA4	160
49	1214	1.6	30	18000			VF 185_30	P132	BE132MA4	BX132MA4	168
49	1214	2.6	30	31500			VF 210_30	P132	BE132MA4	BX132MA4	176

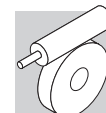

7.5 kW



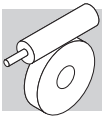

n ₂ min-1	M ₂ Nm	S	i	R _{n2} N							
					IE2	IE3		IE2	IE2		
49	1257	3.1	30	33400			VFR 210_30	P132	BE132MA4	BX132MA4	178
49	1228	3.3	30	4440			VF 250_30	P132	BE132MA4	BX132MA4	182
59	1036	1.4	25	11000			VFR 150_25	P132	BE132MA4	BX132MA4	162
59	1048	2.4	25	16700			VFR 185_25	P132	BE132MA4	BX132MA4	170
64	931	0.9	23	11200			VF 130_23	P132	BE132MA4	BX132MA4	152
64	931	1.3	23	13200			VF 150_23	P132	BE132MA4	BX132MA4	160
64	958	2.3	15	16700			VF 185_15	P160	BE160MB6		168
73	819	1.1	20	10800			VF 130_20	P132	BE132MA4	BX132MA4	152
73	819	1.6	20	12700			VF 150_20	P132	BE132MA4	BX132MA4	160
97	614	1.0	15	7370			W 110_15	P132	BE132MA4	BX132MA4	149
97	629	1.4	15	10200			VF 130_15	P132	BE132MA4	BX132MA4	152
97	636	1.8	15	11700			VF 150_15	P132	BE132MA4	BX132MA4	160
127	479	1.4	23	9900			VF 130_23	P132	BE132SB2		152
127	479	2.0	23	11400			VF 150_23	P132	BE132SB2		160
138	462	2.5	7	10200			VF 150_7	P160	BE160MB6		160
146	424	1.3	10	6720			W 110_10	P132	BE132MA4	BX132MA4	149
146	429	1.8	10	9150			VF 130_10	P132	BE132MA4	BX132MA4	152
146	429	2.4	10	10500			VF 150_10	P132	BE132MA4	BX132MA4	160
195	320	1.7	15	6660			W 110_15	P132	BE132SB2		149
208	304	1.6	7	6100			W 110_7	P132	BE132MA4	BX132MA4	149
208	304	2.4	7	8210			VF 130_7	P132	BE132MA4	BX132MA4	152
208	307	3.3	7	9400			VF 150_7	P132	BE132MA4	BX132MA4	160
293	215	2.2	10	5980			W 110_10	P132	BE132SB2		149
293	217	2.8	10	7840			VF 130_10	P132	BE132SB2		152
418	153	2.9	7	5380			W 110_7	P132	BE132SB2		149
418	154	3.6	7	7010			VF 130_7	P132	BE132SB2		152

9.2 kW





n ₂ min-1	M ₂ Nm	S	i	R _{n2} N							
					IE2	IE3		IE2	IE3		
5.1	9054	1.0	280	52000			VF/VF 130/250_280	P132	BE132MB4		186
9.7	6132	1.1	150	52000			VFR 250_150	P132	BE132MB4	BX160MA4	184
12.1	5198	1.3	120	52000			VFR 250_120	P132	BE132MB4	BX160MA4	184
14.5	4149	0.9	100	47000			VF 250_100	P132	BE132MB4	BX160MA4	182
16.1	4173	1.0	90	34500			VFR 210_90	P132	BE132MB4	BX160MA4	178
16.1	4283	1.4	90	52000			VFR 250_90	P132	BE132MB4	BX160MA4	184
18.1	3368	0.9	80	31500			VF 210_80	P132	BE132MB4	BX160MA4	176
18.1	3466	1.1	80	47000			VF 250_80	P132	BE132MB4	BX160MA4	182
24.2	2672	1.1	60	31500			VF 210_60	P132	BE132MB4	BX160MA4	176
24.2	2929	1.6	60	34500			VFR 210_60	P132	BE132MB4	BX160MA4	178
24.2	2782	1.6	60	47000			VF 250_60	P132	BE132MB4	BX160MA4	182
24.2	2965	2.4	60	51900			VFR 250_60	P132	BE132MB4	BX160MA4	184
29.0	2319	1.1	50	18000			VF 185_50	P132	BE132MB4	BX160MA4	168
29.0	2471	1.3	50	18600			VFR 185_50	P132	BE132MB4		170
29.0	2319	1.4	50	31500			VF 210_50	P132	BE132MB4	BX160MA4	176
29.0	2319	1.9	50	47000			VF 250_50	P132	BE132MB4	BX160MA4	182
32	2279	1.8	45	34500			VFR 210_45	P132	BE132MB4	BX160MA4	178
32	2306	2.8	45	48000			VFR 250_45	P132	BE132MB4	BX160MA4	184
36	1904	1.4	40	18000			VF 185_40	P132	BE132MB4	BX160MA4	168
36	1904	1.8	40	31500			VF 210_40	P132	BE132MB4	BX160MA4	176
36	1928	2.5	40	47000			VF 250_40	P132	BE132MB4	BX160MA4	182
38	1884	0.9	38	11900			VFR 150_37.5	P132	BE132MB4		162
38	1922	1.5	38	17200			VFR 185_37.5	P132	BE132MB4		170
48	1464	0.9	30	11300			VF 150_30	P132	BE132MB4	BX160MA4	160
48	1519	1.3	30	17900			VF 185_30	P132	BE132MB4	BX160MA4	168
48	1519	2.0	30	31500			VF 210_30	P132	BE132MB4	BX160MA4	176
48	1574	2.4	30	32600			VFR 210_30	P132	BE132MB4	BX160MA4	178
48	1538	2.6	30	43900			VF 250_30	P132	BE132MB4	BX160MA4	182
48	1574	3.8	30	42800			VFR 250_30	P132	BE132MB4	BX160MA4	184
58	1297	1.2	25	11200			VFR 150_25	P132	BE132MB4		162
58	1312	2.0	25	15800			VFR 185_25	P132	BE132MB4		170
63	1165	1.1	23	12500			VF 150_23	P132	BE132MB4	BX160MA4	160
73	1025	0.9	20	10100			VF 130_20	P132	BE132MB4	BX160MA4	152
73	1025	1.3	20	12100			VF 150_20	P132	BE132MB4		160
73	1037	3.0	20	30400			VF 210_20	P132	BE132MB4	BX160MA4	176
97	787	1.2	15	9560			VF 130_15	P132	BE132MB4		152
97	796	1.4	15	11200			VF 150_15	P132	BE132MB4	BX160MA4	160
127	601	1.1	23	9510			VF 130_23	P132	BE132MB2		152







9.2 kW

n ₂ min-1	M ₂ Nm	S	i	R _{n2} N	 						
					IE2	IE3	IE2	IE3	IE2		
127	601	1.6	23	11000			VF 150_23	P132	BE132MB2		160
145	531	1.0	10	6210			W 110_10	P132	BE132MB4		149
145	537	1.5	10	8690			VF 130_10	P132	BE132MB4	BX160MA4	152
145	537	2.0	10	16100			VF 150_10	P132	BE132MB4		160
195	396	1.4	15	6320			W 110_15	P132	BE132MB2		149
207	380	1.3	7	5670			W 110_7	P132	BE132MB4		149
207	380	1.9	7	7820			VF 130_7	P132	BE132MB4		152
207	384	2.6	7	9030			VF 150_7	P132	BE132MB4		BX160MA4
292	271	1.8	10	5720			W 110_10	P132	BE132MB2		149
292	274	2.2	10	7620			VF 130_10	P132	BE132MB2		152
292	274	2.9	10	8690			VF 150_10	P132	BE132MB2		160
417	192	2.3	7	5170			W 110_7	P132	BE132MB2		149
417	194	2.9	7	6820			VF 130_7	P132	BE132MB2		152

11 kW





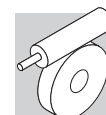

n ₂ min-1	M ₂ Nm	S	i	R _{n2} N	 						
					IE2	IE3	IE2	IE2	IE2		
12.3	6130	1.1	120	52000			VFR 250_120	P160	BE160M4	BX160MB4	184
16.3	5051	1.2	90	52000			VFR 250_90	P160	BE160M4	BX160MB4	184
18.4	4087	0.9	80	47000			VF 250_80	P160	BE160M4	BX160MB4	182
24.5	3151	0.9	60	31500			VF 210_60	P160	BE160M4	BX160MB4	176
24.5	3454	1.3	60	34500			VFR 210_60	P160	BE160M4	BX160MB4	178
24.5	3281	1.4	60	47000			VF 250_60	P160	BE160M4	BX160MB4	182
24.5	3496	2.0	60	50900			VFR 250_60	P160	BE160M4	BX160MB4	184
29.4	2734	1.2	50	31500			VF 210_50	P160	BE160M4	BX160MB4	176
29.4	2734	1.6	50	47000			VF 250_50	P160	BE160M4	BX160MB4	182
33	2688	1.5	45	34500			VFR 210_45	P160	BE160M4	BX160MB4	178
33	2720	2.3	45	47100			VFR 250_45	P160	BE160M4	BX160MB4	184
37	2245	1.2	40	18500			VF 185_40	P160	BE160M4	BX160MB4	168
37	2245	1.5	40	31500			VF 210_40	P160	BE160M4	BX160MB4	176
37	2273	2.1	40	47000			VF 250_40	P160	BE160M4	BX160MB4	182
49	1791	1.1	30	17200			VF 185_30	P160	BE160M4	BX160MB4	168
49	1791	1.7	30	31500			VF 210_30	P160	BE160M4	BX160MB4	176
49	1856	2.0	30	31800			VFR 210_30	P160	BE160M4	BX160MB4	178
49	1813	2.2	30	43400			VF 250_30	P160	BE160M4	BX160MB4	182
49	1856	3.2	30	42100			VFR 250_30	P160	BE160M4	BX160MB4	184
74	1209	1.1	20	11400			VF 150_20	P160	BE160M4	BX160MB4	160
74	1223	1.8	20	15600			VF 185_20	P160	BE160M4	BX160MB4	168
74	1223	2.5	20	30000			VF 210_20	P160	BE160M4	BX160MB4	176
98	939	1.2	15	10600			VF 150_15	P160	BE160M4	BX160MB4	160
98	950	1.9	15	14200			VF 185_15	P160	BE160M4	BX160MB4	168
98	950	3.0	15	27700			VF 210_15	P160	BE160M4	BX160MB4	176
147	630	2.7	20	13300			VF 185_20	P160	BE160MA2		168
147	633	1.6	10	9670			VF 150_10	P160	BE160M4	BX160MB4	160
196	478	2.9	15	12200			VF 185_15	P160	BE160MA2		168
210	454	2.2	7	8660			VF 150_7	P160	BE160M4	BX160MB4	160
294	323	2.4	10	8440			VF 150_10	P160	BE160MA2		160
420	228	3.3	7	7530			VF 150_7	P160	BE160MA2		160

15 kW







n ₂ min-1	M ₂ Nm	S	i	R _{n2} N	 						
					IE2	IE3	IE2	IE3	IE2		
24.5	4474	1.0	60	47000			VF 250_60	P160	BE160L4	BX160LA4	182
24.5	4768	1.5	60	48700			VFR 250_60	P160	BE160L4	BX160LA4	184
29.4	3728	0.9	50	31500			VF 210_50	P160	BE160L4	BX160LA4	176
29.4	3728	1.2	50	47000			VF 250_50	P160	BE160L4	BX160LA4	182
32	3665	1.1	45	33200			VFR 210_45	P160	BE160L4	BX160LA4	178
32	3709	1.7	45	45200			VFR 250_45	P160	BE160L4	BX160LA4	184
37	3061	0.9	40	16600			VF 185_40	P160	BE160L4	BX160LA4	168
37	3061	1.1	40	31500			VF 210_40	P160	BE160L4	BX160LA4	176
37	3100	1.5	40	45900			VF 250_40	P160	BE160L4	BX160LA4	182
49	2443	1.2	30	31500			VF 210_30	P160	BE160L4	BX160LA4	176









15 kW

n ₂ min-1	M ₂ Nm	S	i	Rn ₂ N	 			 			
					IE2	IE3		IE2	IE3		
49	2531	1.5	30	30000			VFR 210_30	P160	BE160L4	BX160LA4	178
49	2473	1.6	30	42400			VF 250_30	P160	BE160L4	BX160LA4	182
49	2531	2.4	30	40600			VFR 250_30	P160	BE160L4	BX160LA4	184
74	1668	1.4	20	14300			VF 185_20	P160	BE160L4	BX160LA4	168
74	1668	1.9	20	29100			VF 210_20	P160	BE160L4	BX160LA4	176
74	1688	2.6	20	38100			VF 250_20	P160	BE160L4	BX160LA4	182
98	1280	0.9	15	9360			VF 150_15	P160	BE160L4	BX160LA4	160
98	1295	1.4	15	13200			VF 185_15	P160	BE160L4	BX160LA4	168
98	1295	2.2	15	27000			VF 210_15	P160	BE160L4	BX160LA4	176
98	1295	3.1	15	35100			VF 250_15	P160	BE160L4	BX160LA4	182
147	855	2.0	20	12700			VF 185_20	P160	BE160MB2		168
147	863	1.2	10	8720			VF 150_10	P160	BE160L4	BX160LA4	160
147	873	3.0	10	24000			VF 210_10	P160	BE160L4	BX160LA4	176
196	649	2.1	15	11600			VF 185_15	P160	BE160MB2		168
196	649	3.3	15	22700			VF 210_15	P160	BE160MB2		176
210	618	1.6	7	7840			VF 150_7	P160	BE160L4	BX160LA4	160
294	437	1.8	10	7960			VF 150_10	P160	BE160MB2		160
420	309	2.4	7	7120			VF 150_7	P160	BE160MB2		160

18.5 kW





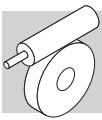

n ₂ min-1	M ₂ Nm	S	i	Rn ₂ N	 			 			
					IE2	IE3		IE2	IE2		
29.4	4560	1.0	50	47000			VF 250_50	P180	BE180M4	BX180M4	182
37	3745	0.9	40	31500			VF 210_40	P180	BE180M4	BX180M4	176
37	3792	1.3	40	44900			VF 250_40	P180	BE180M4	BX180M4	182
49	2988	1.0	30	31200			VF 210_30	P180	BE180M4	BX180M4	176
49	3024	1.3	30	41500			VF 250_30	P180	BE180M4	BX180M4	182
74	2040	1.1	20	13200			VF 185_20	P180	BE180M4	BX180M4	168
74	2040	1.5	20	28300			VF 210_20	P180	BE180M4	BX180M4	176
74	2064	2.1	20	37400			VF 250_20	P180	BE180M4	BX180M4	182
98	1584	1.2	15	12200			VF 185_15	P180	BE180M4	BX180M4	168
98	1584	1.8	15	26200			VF 210_15	P180	BE180M4	BX180M4	176
98	1584	2.5	15	34500			VF 250_15	P180	BE180M4	BX180M4	182
147	1068	1.7	10	11400			VF 185_10	P180	BE180M4	BX180M4	168
147	1068	2.5	10	23400			VF 210_10	P180	BE180M4	BX180M4	176
147	1080	3.4	10	37800			VF 250_10	P180	BE180M4	BX180M4	182
196	805	1.1	15	8260			VF 150_15	P160	BE160L2		160
210	756	2.3	7	10100			VF 185_7	P180	BE180M4	BX180M4	168
210	756	3.0	7	21200			VF 210_7	P180	BE180M4	BX180M4	176
295	543	1.5	10	7550			VF 150_10	P160	BE160L2		160
421	384	2.0	7	6760			VF 150_7	P160	BE160L2		160

22 kW







n ₂ min-1	M ₂ Nm	S	i	Rn ₂ N	 			 			
					IE2	IE3		IE2	IE3		
37	4501	1.1	40	43900			VF 250_40	P180	BE180L4	BX180L4	182
49	3546	0.9	30	30200			VF 210_30	P180	BE180L4	BX180L4	176
49	3589	1.1	30	44700			VF 250_30	P180	BE180L4	BX180L4	182
74	2421	0.9	20	12200			VF 185_20	P180	BE180L4	BX180L4	168
74	2421	1.3	20	27500			VF 210_20	P180	BE180L4	BX180L4	176
74	2450	1.8	20	36700			VF 250_20	P180	BE180L4	BX180L4	182
99	1880	1.0	15	11300			VF 185_15	P180	BE180L4	BX180L4	168
99	1880	1.5	15	25500			VF 210_15	P180	BE180L4	BX180L4	176
99	1880	2.1	15	33900			VF 250_15	P180	BE180L4	BX180L4	182
148	1267	1.4	10	10700			VF 185_10	P180	BE180L4	BX180L4	168
148	1267	2.1	10	22900			VF 210_10	P180	BE180L4	BX180L4	176
148	1282	2.9	10	30300			VF 250_10	P180	BE180L4	BX180L4	182
210	898	1.9	7	9510			VF 185_7	P180	BE180L4	BX180L4	168
210	898	2.5	7	20800			VF 210_7	P180	BE180L4	BX180L4	176
210	908	3.5	7	27500			VF 250_7	P180	BE180L4	BX180L4	182









30 kW

n₂ min ⁻¹	M₂ Nm	S	i	R_{n2} N	  IE...		  IEC 		
147	1754	2,1	10	29200			VF 250_10	P200 IEC200L4	182
210	1228	1,9	7	19700			VF 210_7	P200 IEC200L4	176
210	1242	2,6	7	26600			VF 250_7	P200 IEC200L4	182
295	874	2,3	10	19000			VF 210_10	P200 IEC200LA2	176
421	619	2,8	7	17200			VF 210_7	P200 IEC200LA2	176

37 kW

n₂ min ⁻¹	M₂ Nm	S	i	R_{n2} N	  IE...		  IEC 		
74	4107	1,1	20	22800			VF 250_20	P225 IEC225S4	182
99	3152	0,9	15	22600			VF 210_15	P225 IEC225S4	176
99	3152	1,3	15	31400			VF 250_15	P225 IEC225S4	182
148	2125	1,2	10	20500			VF 210_10	P225 IEC225S4	176
148	2149	1,7	10	28300			VF 250_10	P225 IEC225S4	182
211	1504	1,5	7	18800			VF 210_7	P225 IEC225S4	176
211	1521	2,1	7	25800			VF 250_7	P225 IEC225S4	182
296	1074	1,9	10	18400			VF 210_10	P200 IEC200L2	176
296	1086	2,6	10	24500			VF 250_10	P200 IEC200L2	182
423	760	2,3	7	16800			VF 210_7	P200 IEC200L2	176

45 kW

n₂ min ⁻¹	M₂ Nm	S	i	R_{n2} N	  IE...		  IEC 		
74	4994	0,9	20	32300			VF 250_20	P225 IEC225M4	182
99	3833	1	15	30100			VF 250_15	P225 IEC225M4	182
148	2584	1	10	19200			VF 210_10	P225 IEC225M4	176
148	2613	1,4	10	27300			VF 250_10	P225 IEC225M4	182
211	1829	1,3	7	17800			VF 210_7	P225 IEC225M4	176
211	1850	1,7	7	25000			VF 250_7	P225 IEC225M4	182
296	1307	1,5	10	17800			VF 210_10	P200 IEC225M2	176
296	1321	2,1	10	24000			VF 250_10	P200 IEC225M2	182
423	925	1,9	7	16200			VF 210_7	P200 IEC225M2	176
423	935	2,6	7	21800			VF 250_7	P200 IEC225M2	182

Die technischen Daten müssen als Anhaltswert betrachtet werden, die genaue Konfiguration muss mit den Daten der Motorenlieferanten für Motoren mit Leistungen größer als 22kW abgestimmt werden.

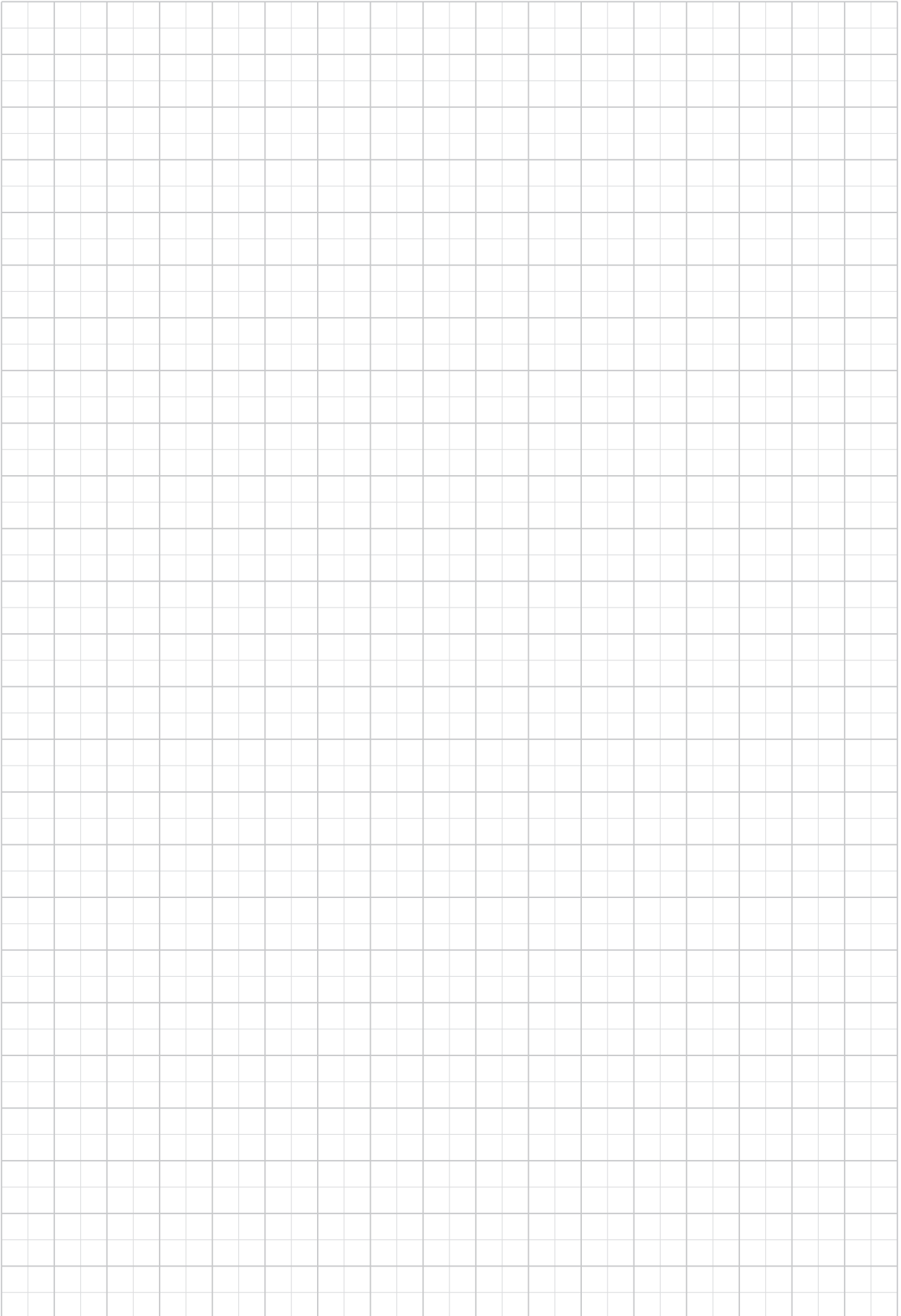
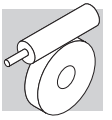

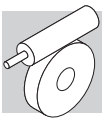

22 GETRIEBE AUSWAHLTABELLEN

VF 27

13 Nm

	i	η_s %	n_2	M_{n2}	P_{n1}	R_{n1}	R_{n2}	η_d	n_2	M_{n2}	P_{n1}	R_{n1}	R_{n2}	η_d		
			min ⁻¹	Nm	kW	N	N	%	min ⁻¹	Nm	kW	N	N	%		
			$n_1 = 2800 \text{ min}^{-1}$						$n_1 = 1400 \text{ min}^{-1}$							
VF 27	VF 27_7	7	67	400	7	0.34	—	330	86	200	9	0.23	35	410	83	187
	VF 27_10	10	62	280	7	0.24	—	400	84	140	9	0.16	30	500	80	
	VF 27_15	15	54	187	7	0.17	—	480	79	93	9	0.12	—	600	75	
	VF 27_20	20	49	140	7	0.14	—	540	76	70	9	0.09	—	600	71	
	VF 27_30	30	38	93	7	0.10	—	600	69	47	9	0.07	—	600	62	
	VF 27_40	40	33	70	7	0.08	—	600	64	35	9	0.06	—	600	57	
	VF 27_60	60	26	47	7	0.06	—	600	56	23.3	9	0.04	—	600	49	
	VF 27_70	70	24	40	7	0.06	—	600	53	20.0	9	0.04	—	600	45	
				$n_1 = 900 \text{ min}^{-1}$						$n_1 = 500 \text{ min}^{-1}$						
	VF 27_7	7	67	129	10	0.17	90	480	81	71	11	0.11	90	600	79	187
	VF 27_10	10	62	90	11	0.13	20	570	78	50	12	0.08	90	600	76	
	VF 27_15	15	54	60	11	0.09	—	600	72	33	12	0.06	90	600	69	
	VF 27_20	20	49	45	11	0.08	—	600	68	25.0	12	0.05	90	600	65	
	VF 27_30	30	38	30.0	11	0.06	—	600	59	16.7	13	0.04	—	600	55	
VF 27_40	40	33	22.5	11	0.05	—	600	54	12.5	13	0.04	—	600	50		
VF 27_60	60	26	15.0	11	0.04	—	600	45	8.3	12	0.02	—	600	41		
VF 27_70	70	24	12.9	10	0.03	—	600	42	7.1	11	0.02	—	600	38		

VF 30

24 Nm

	i	η_s %	n_2	M_{n2}	P_{n1}	R_{n1}	R_{n2}	η_d	n_2	M_{n2}	P_{n1}	R_{n1}	R_{n2}	η_d		
			min ⁻¹	Nm	kW	N	N	%	min ⁻¹	Nm	kW	N	N	%		
			$n_1 = 2800 \text{ min}^{-1}$						$n_1 = 1400 \text{ min}^{-1}$							
VF 30	VF 30_7	7	69	400	12	0.58	120	510	87	200	16	0.41	140	630	84	188
	VF 30_10	10	64	280	12	0.41	70	620	85	140	16	0.30	80	770	81	
	VF 30_15	15	56	187	14	0.34	—	720	81	93	18	0.24	—	910	76	
	VF 30_20	20	51	140	14	0.26	—	820	78	70	18	0.19	—	1030	73	
	VF 30_30	30	41	93	15	0.21	—	960	71	47	20	0.15	—	1200	65	
	VF 30_40	40	36	70	14	0.16	—	1090	66	35	19	0.12	—	1360	60	
	VF 30_60	60	29	47	14	0.12	—	1270	59	23.3	19	0.09	—	1590	51	
	VF 30_70	70	26	40	11	0.08	—	1380	55	20.0	15	0.07	—	1600	48	
				$n_1 = 900 \text{ min}^{-1}$						$n_1 = 500 \text{ min}^{-1}$						
	VF 30_7	7	69	129	18	0.30	150	730	82	71	20	0.19	150	920	81	188
	VF 30_10	10	64	90	18	0.22	150	900	79	50	20	0.14	150	1120	77	
	VF 30_15	15	56	60	20	0.17	—	1060	74	33	22	0.11	150	1320	71	
	VF 30_20	20	51	45	20	0.14	—	1200	70	25.0	22	0.09	150	1490	67	
	VF 30_30	30	41	30	22	0.12	—	1400	61	16.7	24	0.07	—	1700	58	
VF 30_40	40	36	23	20	0.09	—	1590	56	12.5	22	0.06	—	1700	53		
VF 30_60	60	29	15	20	0.07	—	1650	48	8.3	22	0.05	—	1700	44		
VF 30_70	70	26	13	17	0.05	—	1700	45	7.0	19	0.04	—	1700	41		

(-) Nehmen Sie bitte Kontakt mit unserem Applikationsdienst und Querkräften Daten angeben (Drehrichtung, Orientierung, Anordnung)

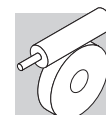

VF 44 - VF/VF 30/44

55 Nm

		i	η _s %	n ₁ = 2800 min ⁻¹						n ₁ = 1400 min ⁻¹								
				n ₂ min ⁻¹	M _{n2} Nm	P _{n1} kW	R _{n1} N	R _{n2} N	η _d %	n ₂ min ⁻¹	M _{n2} Nm	P _{n1} kW	R _{n1} N	R _{n2} N	η _d %			
				VF 44	VF 44_7	7	71	400	22	1.1	220	950	88	200	29		0.71	220
VF 44_10	10	66	280		22	0.74	220	1150	87	140	29	0.51	220	1430	84			
VF 44_14	14	60	200		22	0.55	220	1340	84	100	29	0.37	220	1680	81			
VF 44_20	20	55	140		29	0.52	220	1490	81	70	39	0.37	220	1860	77			
VF 44_28	28	45	100		29	0.40	220	1710	76	50	39	0.29	220	2140	71			
VF 44_35	35	42	80		29	0.33	220	1870	73	40	39	0.25	220	2300	68			
VF 44_46	46	37	61		29	0.27	220	2080	69	30.0	39	0.19	220	2300	63			
VF 44_60	60	32	47		29	0.22	220	2290	65	23.3	39	0.16	220	2300	58			
VF 44_70	70	30	40		22	0.15	220	2300	62	20.0	29	0.11	220	2300	55			
VF 44_100	100	24	28		21	0.11	220	2300	55	14.0	28	0.09	220	2300	47			
					n ₁ = 900 min ⁻¹						n ₁ = 500 min ⁻¹							
VF 44_7	7	71	129		39	0.63	220	1300	85	71	45	0.41	220	1610	83	188		
VF 44_10	10	66	90		39	0.45	220	1610	82	50	45	0.29	220	1980	80			
VF 44_14	14	60	64		39	0.34	220	1890	78	36	50	0.25	220	2280	76			
VF 44_20	20	55	45		45	0.29	220	2160	74	25.0	50	0.18	220	2500	72			
VF 44_28	28	45	32		49	0.24	220	2300	67	17.9	55	0.16	220	2500	64			
VF 44_35	35	42	25.7		49	0.20	220	2300	64	14.3	55	0.14	220	2500	60			
VF 44_46	46	37	19.6		49	0.17	220	2300	59	10.9	50	0.10	220	2500	55			
VF 44_60	60	32	15.0	45	0.13	200	2300	54	8.3	50	0.09	220	2500	50				
VF 44_70	70	30	12.9	39	0.10	220	2300	51	7.1	45	0.07	220	2500	47				
VF 44_100	100	24	9.0	30	0.06	220	2300	43	5.0	32	0.04	220	2500	39				

70 Nm

		i	η _s %	n ₁ = 1400 min ⁻¹						n ₁ = 900 min ⁻¹						
				n ₂ min ⁻¹	M _{n2} Nm	P _{n1} kW	R _{n1} N	R _{n2} N	η _d %	n ₂ min ⁻¹	M _{n2} Nm	P _{n1} kW	R _{n1} N	R _{n2} N	η _d %	
				VF/VF 30/44	VF/VF 30/44_245	245	29	5.7	60	0.09	140	2500	40	3.7	70	
VF/VF 30/44_350	350	27	4.0		60	0.07	80	2500	36	2.6	70	0.05	150	2500	38	
VF/VF 30/44_420	420	25	3.3		60	0.06	—	2500	35	2.1	70	0.04	—	2500	39	
VF/VF 30/44_560	560	23	2.5		60	0.05	—	2500	31	1.6	70	0.04	—	2500	29	
VF/VF 30/44_700	700	21	2.0		60	0.04	—	2500	31	1.3	70	0.03	—	2500	31	
VF/VF 30/44_840	840	18	1.7		60	0.04	—	2500	26	1.1	70	0.03	—	2500	26	
VF/VF 30/44_1120	1120	16	1.3		60	0.03	—	2500	26	0.80	70	0.02	—	2500	29	
VF/VF 30/44_1680	1680	13	0.83		60	0.02	—	2500	26	0.54	70	0.02	—	2500	20	
VF/VF 30/44_2100	2100	12	0.67		60	0.02	—	2500	21	0.43	70	0.02	—	2500	16	

(-) Nehmen Sie bitte Kontakt mit unserem Applikationsdienst und Querkräften an (Drehrichtung, Orientierung, Anordnung)

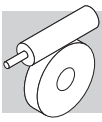

VF 49 - VFR 49

88 Nm

		i	η _s %	n ₁ = 2800 min ⁻¹						n ₁ = 1400 min ⁻¹						
				n ₂ min ⁻¹	M _{n2} Nm	P _{n1} kW	R _{n1} N	R _{n2} N	η _d %	n ₂ min ⁻¹	M _{n2} Nm	P _{n1} kW	R _{n1} N	R _{n2} N	η _d %	
				VF 49												
	VF 49_7	7	70	400	41	2.0	400	950	88	200	54	1.3	400	1170	86	188
	VF 49_10	10	65	280	44	1.5	400	1140	86	140	59	1.0	400	1410	84	
	VF 49_14	14	59	200	49	1.2	400	1310	84	100	65	0.90	400	1630	81	
	VF 49_18	18	55	156	44	0.87	400	1520	82	78	59	0.60	400	1890	78	
	VF 49_24	24	50	117	47	0.73	400	1670	79	58	63	0.50	400	2110	75	
	VF 49_28	28	43	100	56	0.78	400	1740	75	50	74	0.55	400	2170	71	
	VF 49_36	36	39	78	52	0.59	400	1970	72	39	69	0.42	400	2460	67	
	VF 49_45	45	35	62	49	0.46	400	2180	69	31	65	0.33	400	2725	63	
	VF 49_60	60	30	47	44	0.34	400	2480	64	23.3	59	0.25	400	3100	58	
	VF 49_70	70	28	40	41	0.28	400	2650	61	20.0	55	0.21	400	3150	54	
	VF 49_80	80	25	35	41	0.25	400	2780	59	17.5	54	0.19	400	3150	52	
	VF 49_100	100	22	28.0	37	0.20	400	3050	54	14.0	49	0.13	400	3150	47	
				n ₁ = 900 min ⁻¹						n ₁ = 500 min ⁻¹						
	VF 49_7	7	70	129	61	0.97	400	1370	85	71	74	0.67	400	1670	83	188
	VF 49_10	10	65	90	64	0.75	400	1670	82	50	74	0.49	400	2060	80	
	VF 49_14	14	59	64	71	0.61	400	1920	78	36	78	0.39	400	2400	75	
	VF 49_18	18	55	50	68	0.47	400	2190	75	27.8	74	0.30	400	2730	72	
	VF 49_24	24	50	38	68	0.36	400	2480	71	20.8	74	0.24	400	3090	68	
	VF 49_28	28	43	32	82	0.41	400	2540	67	17.9	88	0.26	400	3180	63	
	VF 49_36	36	39	25.0	75	0.31	400	2880	63	13.9	80	0.20	400	3450	59	
	VF 49_45	45	35	20.0	71	0.25	400	3190	59	11.1	78	0.17	400	3450	55	
	VF 49_60	60	30	15.0	64	0.19	400	3300	53	8.3	69	0.12	400	3450	49	
	VF 49_70	70	28	12.9	60	0.16	400	3300	50	7.1	69	0.11	400	3450	46	
	VF 49_80	80	25	11.3	58	0.14	400	3300	47	6.3	59	0.09	400	3450	43	
	VF 49_100	100	22	9.0	52	0.11	400	3300	42	5.0	59	0.08	400	3450	38	



95 Nm

		i	η _s %	n ₁ = 2800 min ⁻¹						n ₁ = 1400 min ⁻¹						
				n ₂ min ⁻¹	M _{n2} Nm	P _{n1} kW	R _{n1} N	R _{n2} N	η _d %	n ₂ min ⁻¹	M _{n2} Nm	P _{n1} kW	R _{n1} N	R _{n2} N	η _d %	
				VFR 49												
	VFR 49_42	42	58	67	71	0.65	230	1920	76	33	78	0.37	230	2500	74	189
	VFR 49_54	54	54	52	68	0.50	230	2180	74	25.9	74	0.28	230	2830	71	
	VFR 49_72	72	49	39	68	0.40	230	2470	70	19.4	74	0.22	230	3190	67	
	VFR 49_84	84	42	33	82	0.44	230	2520	66	16.6	88	0.25	230	3290	62	
	VFR 49_108	108	38	25.9	75	0.33	230	2860	62	12.9	80	0.19	230	3450	58	
	VFR 49_135	135	34	20.7	71	0.27	230	3160	58	10.3	88	0.18	230	3450	54	
	VFR 49_180	180	29	15.6	64	0.20	230	3300	52	7.7	69	0.12	230	3450	48	
	VFR 49_210	210	27	13.3	60	0.17	230	3300	49	6.6	69	0.11	230	3450	45	
	VFR 49_240	240	25	11.7	58	0.15	230	3300	46	5.8	59	0.09	230	3450	42	
	VFR 49_300	300	22	9.3	52	0.12	230	3300	41	4.7	59	0.08	230	3450	37	
				n ₁ = 900 min ⁻¹						n ₁ = 500 min ⁻¹						
	VFR 49_42	42	58	21.4	82	0.26	230	2960	72	11.9	90	0.16	230	3450	70	189
	VFR 49_54	54	54	16.7	79	0.20	230	3330	69	9.3	83	0.12	230	3450	67	
	VFR 49_72	72	49	12.5	79	0.16	230	3450	64	6.9	83	0.10	230	3450	62	
	VFR 49_84	84	42	10.7	91	0.17	230	3450	59	6.0	95	0.10	230	3450	57	
	VFR 49_108	108	38	8.3	84	0.13	230	3450	55	4.6	90	0.08	230	3450	52	
	VFR 49_135	135	34	6.7	82	0.11	230	3450	50	3.7	90	0.07	230	3450	48	
	VFR 49_180	180	29	5.0	75	0.09	230	3450	45	2.8	78	0.05	230	3450	42	
	VFR 49_210	210	27	4.3	75	0.08	230	3450	41	2.4	78	0.05	230	3450	39	
	VFR 49_240	240	25	3.8	64	0.06	230	3450	39	2.1	68	0.04	230	3450	36	
	VFR 49_300	300	22	3.0	63	0.06	230	3450	34	1.7	65	0.04	230	3450	32	



VF/VF 30/49

100 Nm

		i	η _s %	n ₁ = 1400 min ⁻¹						n ₁ = 900 min ⁻¹						
				n ₂ min ⁻¹	M _{n2} Nm	P _{n1} kW	R _{n1} N	R _{n2} N	η _d %	n ₂ min ⁻¹	M _{n2} Nm	P _{n1} kW	R _{n1} N	R _{n2} N	η _d %	
VF/VF 30/49	VF/VF 30/49_240	240	32	5.8	95	0.13	80	3450	45	3.8	100	0.09	150	3450	44	190
	VF/VF 30/49_315	315	24	4.4	95	0.11	140	3450	40	2.9	100	0.07	150	3450	43	
	VF/VF 30/49_420	420	24	3.3	95	0.08	—	3450	41	2.1	100	0.06	—	3450	37	
	VF/VF 30/49_540	540	22	2.6	95	0.07	—	3450	37	1.7	100	0.05	—	3450	35	
	VF/VF 30/49_720	720	20	1.9	95	0.05	—	3450	39	1.3	100	0.04	—	3450	33	
	VF/VF 30/49_900	900	18	1.6	95	0.05	—	3450	31	1.0	100	0.04	—	3450	26	
	VF/VF 30/49_1120	1120	15	1.3	95	0.04	—	3450	31	0.80	100	0.03	—	3450	28	
	VF/VF 30/49_1440	1440	14	0.97	95	0.04	—	3450	24	0.63	100	0.03	—	3450	22	
	VF/VF 30/49_2160	2160	11	0.65	95	0.03	—	3450	21	0.42	100	0.02	—	3450	22	
	VF/VF 30/49_2700	2700	10	0.52	95	0.03	—	3450	17	0.33	100	0.02	—	3450	17	

(-) Nehmen Sie bitte Kontakt mit unserem Applikationsdienst und Querkraftsdaten angeben (Drehrichtung, Orientierung, Anordnung)



W 63 - WR 63

190 Nm

		i	η _s %	n ₁ = 2800 min ⁻¹					n ₁ = 1400 min ⁻¹								
				n ₂ min ⁻¹	M _{n2} Nm	P _{n1} kW	R _{n1} N	R _{n2} N	η _d %	n ₂ min ⁻¹	M _{n2} Nm	P _{n1} kW	R _{n1} N		R _{n2} N	η _d %	
				W 63													
W 63	W 63_7	7	70	400	105	4.9	480	1010	90	200	120	2.9	480	1550	88	188	
	W 63_10	10	66	280	125	4.2	370	1360	88	140	140	2.4	480	1840	86		
	W 63_12	12	63	233	125	3.5	435	1540	87	117	140	2.0	480	2070	85		
	W 63_15	15	59	187	125	2.8	410	1770	86	93	150	1.8	480	2280	83		
	W 63_19	19	55	147	130	2.4	310	1990	84	74	150	1.4	480	2600	81		
	W 63_24	24	52	117	130	1.9	370	2250	82	58	155	1.2	480	2890	78		
	W 63_30	30	44	93	125	1.6	440	2540	78	47	160	1.1	460	3170	74		
	W 63_38	38	40	74	130	1.3	330	2800	75	37	155	0.85	480	3580	70		
	W 63_45	45	37	62	130	1.2	380	3020	73	31	145	0.71	480	3920	67		
	W 63_64	64	31	44	110	0.75	480	3650	67	21.9	125	0.47	480	4680	61		
W 63_80	80	27	35	100	0.59	480	4050	62	17.5	115	0.38	480	5000	56			
W 63_100	100	23	28	100	0.51	480	4420	58	14.0	115	0.33	480	5000	51			
				n ₁ = 900 min ⁻¹					n ₁ = 500 min ⁻¹								
W 63	W 63_7	7	70	129	130	2.0	480	1870	87	71	140	1.2	480	2420	84	188	
	W 63_10	10	66	90	150	1.7	480	2220	84	50	165	1.1	480	2830	81		
	W 63_12	12	63	75	150	1.4	480	2480	82	42	165	0.92	480	3140	79		
	W 63_15	15	59	60	160	1.3	480	2740	80	33	180	0.83	480	3430	76		
	W 63_19	19	55	47	160	1.0	480	3100	78	26.3	180	0.68	480	3860	73		
	W 63_24	24	52	38	165	0.86	480	3440	75	20.8	185	0.58	480	4280	70		
	W 63_30	30	44	30	170	0.76	480	3770	70	16.7	190	0.52	480	4690	64		
	W 63_38	38	40	23.7	165	0.62	480	4240	66	13.2	185	0.42	480	5000	61		
	W 63_45	45	37	20.0	155	0.52	480	4630	63	11.1	170	0.34	480	5000	58		
	W 63_64	64	31	14.1	135	0.35	480	5000	56	7.8	150	0.24	480	5000	51		
W 63_80	80	27	11.3	125	0.28	480	5000	52	6.3	135	0.19	480	5000	46			
W 63_100	100	23	9.0	120	0.25	480	5000	46	5.0	130	0.17	480	5000	41			

220 Nm

		i	η _s %	n ₁ = 2800 min ⁻¹					n ₁ = 1400 min ⁻¹								
				n ₂ min ⁻¹	M _{n2} Nm	P _{n1} kW	R _{n1} N	R _{n2} N	η _d %	n ₂ min ⁻¹	M _{n2} Nm	P _{n1} kW	R _{n1} N		R _{n2} N	η _d %	
				WR 63													
WR 63	WR 63_21	21	69	133	130	2.1	180	1840	87	67	140	1.2	320	2510	84	189	
	WR 63_30	30	65	93	150	1.7	300	2180	84	47	165	1.0	320	2920	81		
	WR 63_36	36	62	78	150	1.5	320	2430	82	39	165	0.85	320	3240	79		
	WR 63_45	45	58	62	160	1.3	320	2690	80	31	180	0.77	320	3540	76		
	WR 63_57	57	54	49	160	1.1	320	3050	78	24.6	180	0.63	320	3980	73		
	WR 63_72	72	51	39	165	0.90	320	3390	75	19.4	185	0.54	320	4410	70		
	WR 63_90	90	44	31	170	0.79	320	3710	70	15.6	190	0.48	320	4830	64		
	WR 63_114	114	39	24.6	165	0.62	320	4170	68	12.3	185	0.39	320	5000	61		
	WR 63_135	135	36	20.7	155	0.53	320	4560	63	10.4	170	0.32	320	5000	58		
	WR 63_192	192	30	14.6	135	0.37	320	5000	56	7.3	150	0.22	320	5000	51		
WR 63_240	240	26	11.7	125	0.29	320	5000	52	5.8	135	0.18	320	5000	46			
WR 63_300	300	22	9.3	120	0.25	320	5000	46	4.7	130	0.15	320	5000	41			
				n ₁ = 900 min ⁻¹					n ₁ = 500 min ⁻¹								
WR 63	WR 63_21	21	69	43	155	0.85	320	2960	82	23.8	170	0.53	320	3750	80	189	
	WR 63_30	30	65	30	180	0.72	320	3470	79	16.7	200	0.45	320	4360	77		
	WR 63_36	36	62	25.0	180	0.61	320	3830	77	14.0	200	0.40	320	4790	74		
	WR 63_45	45	58	20.0	190	0.54	320	4230	74	11.1	200	0.33	320	5000	71		
	WR 63_57	57	54	15.8	190	0.44	320	4740	71	8.8	200	0.27	320	5000	68		
	WR 63_72	72	51	12.5	190	0.37	320	5000	68	6.9	190	0.22	320	5000	64		
	WR 63_90	90	44	10.0	205	0.35	320	5000	62	5.6	220	0.22	320	5000	58		
	WR 63_114	114	39	7.9	200	0.29	320	5000	58	4.4	210	0.18	320	5000	54		
	WR 63_135	135	36	6.7	180	0.23	320	5000	54	3.7	190	0.15	320	5000	50		
	WR 63_192	192	30	4.7	150	0.16	320	5000	47	2.6	150	0.10	320	5000	43		
WR 63_240	240	26	3.8	140	0.13	320	5000	43	2.1	140	0.08	320	5000	39			
WR 63_300	300	22	3.0	130	0.11	320	5000	38	1.7	130	0.07	320	5000	34			

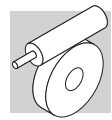

VF/W 30/63

230 Nm

		i	η _s %	n ₁ = 1400 min ⁻¹						n ₁ = 900 min ⁻¹						
				n ₂ min ⁻¹	M _{n2} Nm	P _{n1} kW	R _{n1} N	R _{n2} N	η _d %	n ₂ min ⁻¹	M _{n2} Nm	P _{n1} kW	R _{n1} N	R _{n2} N	η _d %	
				VF/W 30/63												
	VF/W 30/63_240	240	33	5.8	210	0.27	80	5000	47	3.8	230	0.20	150	5000	45	190
	VF/W 30/63_315	315	26	4.4	210	0.23	140	5000	42	2.9	230	0.17	150	5000	41	
	VF/W 30/63_450	450	25	3.1	210	0.17	—	5000	41	2.0	230	0.11	—	5000	42	
	VF/W 30/63_570	570	22	2.5	210	0.14	—	5000	40	1.6	230	0.11	—	5000	36	
	VF/W 30/63_720	720	21	1.9	210	0.12	—	5000	37	1.3	230	0.09	—	5000	32	
	VF/W 30/63_900	900	18	1.6	210	0.11	—	5000	30	1.0	230	0.08	—	5000	29	
	VF/W 30/63_1200	1200	16	1.2	210	0.11	—	5000	24	0.75	230	0.07	—	5000	25	
	VF/W 30/63_1520	1520	14	0.92	210	0.08	—	5000	24	0.59	230	0.06	—	5000	23	
	VF/W 30/63_2280	2280	12	0.61	210	0.06	—	5000	21	0.39	230	0.04	—	5000	23	
	VF/W 30/63_2700	2700	11	0.52	210	0.05	—	5000	22	0.33	230	0.04	—	5000	19	

(-) Nehmen Sie bitte Kontakt mit unserem Applikationsdienst und Querkräften an (Drehrichtung, Orientierung, Anordnung)



W 75 - WR 75

320 Nm

		i	η _s %	n ₁ = 2800 min ⁻¹						n ₁ = 1400 min ⁻¹							
				n ₂ min ⁻¹	M _{n2} Nm	P _{n1} kW	R _{n1} N	R _{n2} N	η _d %	n ₂ min ⁻¹	M _{n2} Nm	P _{n1} kW	R _{n1} N	R _{n2} N	η _d %		
				W 75													
W 75	W 75_7	7	71	400	170	7.8	750	700	91	200	190	4.4	750	1530	90	188	
	W 75_10	10	67	280	205	6.7	750	1610	90	140	230	3.8	750	2240	88		
	W 75_15	15	60	187	225	5.0	750	2120	88	93	250	2.9	750	2870	85		
	W 75_20	20	56	140	225	3.8	750	2550	86	70	250	2.2	750	3410	83		
	W 75_25	25	52	112	225	3.2	750	2900	83	56	250	1.8	750	3840	80		
	W 75_30	30	45	93	240	2.9	750	3100	81	47	270	1.7	750	4090	77		
	W 75_40	40	40	70	225	2.1	750	3660	77	35	255	1.3	750	4770	72		
	W 75_50	50	36	56	195	1.6	750	4180	73	28.0	220	0.95	750	5410	68		
	W 75_60	60	33	47	180	1.3	750	4610	70	23.3	200	0.75	750	5960	65		
	W 75_80	80	28	35	160	0.90	750	5310	65	17.5	180	0.56	750	6200	59		
W 75_100	100	25	28.0	135	0.65	750	5960	61	14.0	150	0.40	750	6200	55			
				n ₁ = 900 min ⁻¹						n ₁ = 500 min ⁻¹							
WR 75	W 75_7	7	71	129	205	3.1	750	2120	88	71	225	2.0	750	2940	86	188	
	W 75_10	10	67	90	250	2.7	750	2700	86	50	275	1.7	750	3480	84		
	W 75_15	15	60	60	270	2.0	750	3440	83	33	295	1.3	750	4380	80		
	W 75_20	20	56	45	270	1.6	750	4050	80	25.0	295	1.0	750	5120	77		
	W 75_25	25	52	36	270	1.3	750	4550	77	20.0	295	0.85	750	5720	73		
	W 75_30	30	45	30	290	1.2	750	4860	74	16.7	320	0.81	750	6080	69		
	W 75_40	40	40	22.5	275	1.0	750	5630	68	12.5	305	0.63	750	6200	63		
	W 75_50	50	36	18.0	235	0.70	750	6200	63	10.0	260	0.47	750	6200	58		
	W 75_60	60	33	15.0	215	0.56	750	6200	60	8.3	235	0.37	750	6200	55		
	W 75_80	80	28	11.3	195	0.43	750	6200	54	6.3	215	0.29	750	6200	49		
W 75_100	100	25	9.0	160	0.30	750	6200	50	5.0	180	0.21	750	6200	44			

420 Nm

		i	η _s %	n ₁ = 2800 min ⁻¹						n ₁ = 1400 min ⁻¹							
				n ₂ min ⁻¹	M _{n2} Nm	P _{n1} kW	R _{n1} N	R _{n2} N	η _d %	n ₂ min ⁻¹	M _{n2} Nm	P _{n1} kW	R _{n1} N	R _{n2} N	η _d %		
				WR 75													
WR 75	WR 75_21	21	70	133	205	3.3	500	2030	88	67	225	1.8	500	3060	86	189	
	WR 75_30	30	66	93	250	2.8	500	2640	86	47	275	1.6	500	3610	84		
	WR 75_45	45	59	62	270	2.1	500	3380	83	31	295	1.2	500	4530	80		
	WR 75_60	60	55	47	270	1.6	500	3980	80	23.3	295	0.94	500	5280	77		
	WR 75_75	75	51	37	270	1.4	500	4480	77	18.7	295	0.79	500	5890	73		
	WR 75_90	90	44	31	290	1.3	500	4780	74	15.6	320	0.76	500	6200	69		
	WR 75_120	120	39	23.3	275	1.0	500	5540	68	11.7	305	0.59	500	6200	63		
	WR 75_150	150	35	18.7	235	0.73	500	6200	63	9.3	260	0.44	500	6200	58		
	WR 75_180	180	32	15.6	215	0.58	500	6200	60	7.8	235	0.35	500	6200	55		
	WR 75_240	240	27	11.7	195	0.44	500	6200	54	5.8	215	0.27	500	6200	49		
WR 75_300	300	24	9.3	160	0.31	500	6200	50	4.7	180	0.20	500	6200	44			
				n ₁ = 900 min ⁻¹						n ₁ = 500 min ⁻¹							
WR 75	WR 75_21	21	70	43	245	1.3	500	3660	85	23.8	270	0.82	500	4660	82	189	
	WR 75_30	30	66	30	330	1.3	500	4070	82	16.7	370	0.81	500	5160	80		
	WR 75_45	45	59	20.0	350	0.94	500	5180	78	11.1	400	0.62	500	6200	75		
	WR 75_60	60	55	15.0	330	0.69	500	6180	75	8.3	370	0.45	500	6200	71		
	WR 75_75	75	51	12.0	330	0.59	500	6200	70	6.7	350	0.37	500	6200	66		
	WR 75_90	90	44	10.0	370	0.58	500	6200	67	5.6	420	0.39	500	6200	63		
	WR 75_120	120	39	7.5	330	0.43	500	6200	60	4.2	380	0.30	500	6200	56		
	WR 75_150	150	35	6.0	310	0.35	500	6200	55	3.3	350	0.24	500	6200	51		
	WR 75_180	180	32	5.0	280	0.29	500	6200	51	2.8	320	0.20	500	6200	47		
	WR 75_240	240	27	3.8	220	0.19	500	6200	45	2.1	280	0.15	500	6200	41		
WR 75_300	300	24	3.0	200	0.15	500	6200	41	1.7	260	0.12	500	6200	37			



WR 75 - VF/W 44/75

370 Nm

				i	η_s %	n_2 min ⁻¹	M_{n2} Nm	P_{n1} kW	R_{n1} N	R_{n2} N	η_d %	n_2 min ⁻¹	M_{n2} Nm		P_{n1} kW	R_{n1} N	R_{n2} N	η_d %
WR 75_P90 B5																189		
	WR 75_15	15	66	187	220	4.9	—	1960	89	93	250	2.9	—	2640	86			
	WR 75_22.5	22.5	59	124	240	3.7	—	2530	86	62	270	2.1	—	3380	83			
	WR 75_30	30	55	93	240	2.8	—	3020	84	47	270	1.7	—	3980	80			
	WR 75_37.5	37.5	51	75	240	2.3	—	3410	81	37	270	1.4	—	4480	77			
	WR 75_45	45	44	62	255	2.1	—	3660	79	31	290	1.3	—	4780	74			
	WR 75_60	60	39	47	240	1.6	—	4290	74	23.3	275	1.0	—	5540	68			
	WR 75_75	75	35	37	210	1.2	—	4860	70	18.7	235	0.74	—	6200	63			
	WR 75_90	90	32	31	190	0.93	—	4460	67	15.6	215	0.59	—	6200	60			
	WR 75_120	120	27	23.3	170	0.69	—	4960	61	11.7	195	0.44	—	6200	54			
WR 75_150	150	24	18.7	145	0.49	—	5150	58	9.3	160	0.32	—	6200	50				
				$n_1 = 900 \text{ min}^{-1}$					$n_1 = 500 \text{ min}^{-1}$									
WR 75_P90 B5																189		
	WR 75_15	15	66	60	275	2.1	—	3150	84	33	330	1.4	—	3850	82			
	WR 75_22.5	22.5	59	40	295	1.6	—	4010	80	22.2	350	1.0	—	4920	78			
	WR 75_30	30	55	30	295	1.2	—	4710	77	16.7	330	0.77	—	5890	75			
	WR 75_37.5	37.5	51	24	295	1.0	—	5280	73	13.3	330	0.66	—	6200	70			
	WR 75_45	45	44	20	320	0.98	—	5610	69	11.1	370	0.64	—	6200	67			
	WR 75_60	60	39	15	305	0.77	—	6200	63	8.3	330	0.48	—	6200	60			
	WR 75_75	75	35	12	260	0.57	—	6200	58	6.7	310	0.39	—	6200	55			
	WR 75_90	90	32	10	235	0.45	—	6200	55	5.6	280	0.32	—	6200	52			
	WR 75_120	120	27	7.5	215	0.35	—	6200	49	4.2	220	0.21	—	6200	46			
WR 75_150	150	24	6.0	180	0.26	—	6200	44	3.3	200	0.17	—	6200	41				

400 Nm



				i	η_s %	n_2 min ⁻¹	M_{n2} Nm	P_{n1} kW	R_{n1} N	R_{n2} N	η_d %	n_2 min ⁻¹	M_{n2} Nm		P_{n1} kW	R_{n1} N	R_{n2} N	η_d %
VF/W 44/75																190		
	VF/W 44/75_250	250	34	5.6	370	0.38	220	4560	57	3.6	400	0.29	220	4660	52			
	VF/W 44/75_300	300	30	4.7	370	0.35	220	5160	51	3.0	400	0.27	220	5150	46			
	VF/W 44/75_400	400	26	3.5	370	0.29	220	6200	46	2.3	400	0.22	220	6200	42			
	VF/W 44/75_525	525	25	2.7	370	0.23	220	6200	44	1.7	400	0.18	220	6200	41			
	VF/W 44/75_700	700	24	2.0	370	0.18	220	6200	42	1.3	400	0.14	220	6200	39			
	VF/W 44/75_920	920	21	1.5	370	0.15	—	6200	40	1.0	400	0.11	60	6200	36			
	VF/W 44/75_1200	1200	18	1.2	370	0.12	—	6200	37	0.75	400	0.10	220	6200	31			
	VF/W 44/75_1500	1500	17	0.93	370	0.10	220	6200	37	0.60	400	0.09	220	6200	29			
	VF/W 44/75_2100	2100	14	0.67	370	0.09	220	6200	30	0.43	400	0.07	220	6200	24			
VF/W 44/75_2800	2800	12	0.50	370	0.07	220	6200	26	0.32	400	0.06	220	6200	22				

(-) Nehmen Sie bitte Kontakt mit unserem Applikationsdienst und Querkraftsdaten angeben (Drehrichtung, Orientierung, Anordnung)





W 86 - WR 86

440 Nm

		i	η_s %	$n_1 = 2800 \text{ min}^{-1}$					$n_1 = 1400 \text{ min}^{-1}$								
				n_2 min ⁻¹	M_{n2} Nm	P_{n1} kW	R_{n1} N	R_{n2} N	η_d %	n_2 min ⁻¹	M_{n2} Nm	P_{n1} kW	R_{n1} N		R_{n2} N	η_d %	
W 86	W 86_7	7	71	400	225	10.4	850	2930	91	200	250	5.9	850	3920	89	188	
	W 86_10	10	67	280	260	8.5	850	3490	90	140	290	4.8	850	4620	88		
	W 86_15	15	60	187	295	6.6	850	4200	87	93	330	3.8	850	5510	85		
	W 86_20	20	60	140	285	4.9	850	4900	86	70	320	2.8	850	6380	84		
	W 86_23	23	58	122	285	4.3	850	5250	85	61	320	2.5	850	6800	82		
	W 86_30	30	45	93	320	3.9	850	5740	81	47	370	2.4	850	7000	76		
	W 86_40	40	45	70	295	2.7	850	6670	79	35	330	1.6	850	7000	75		
	W 86_46	46	43	61	305	2.5	850	7000	77	30	340	1.5	850	7000	73		
	W 86_56	56	39	50	265	1.8	850	7000	75	25.0	300	1.1	850	7000	70		
	W 86_64	64	37	44	250	1.6	850	7000	73	21.9	280	0.94	850	7000	68		
	W 86_80	80	33	35	225	1.2	850	7000	69	17.5	255	0.73	850	7000	64		
	W 86_100	100	29	28.0	205	0.92	850	7000	65	14.0	230	0.57	850	7000	59		
					$n_1 = 900 \text{ min}^{-1}$					$n_1 = 500 \text{ min}^{-1}$							
	W 86_7	7	71	129	270	4.1	850	4670	88	71	295	2.6	850	5890	85		188
	W 86_10	10	67	90	310	3.4	850	5500	86	50	345	2.2	850	6860	82		
	W 86_15	15	60	60	355	2.7	850	6520	82	33	390	1.7	850	7000	78		
	W 86_20	20	60	45	345	2.0	850	7000	81	25.0	380	1.3	850	7000	77		
	W 86_23	23	58	39	345	1.8	850	7000	80	21.7	380	1.2	850	7000	75		
	W 86_30	30	45	30	400	1.7	850	7000	73	16.7	440	1.1	850	7000	67		
W 86_40	40	45	22.5	355	1.2	850	7000	71	12.5	390	0.77	850	7000	66			
W 86_46	46	43	19.6	365	1.1	850	7000	69	10.9	405	0.73	850	7000	63			
W 86_56	56	39	16.1	325	0.83	850	7000	66	8.9	355	0.55	850	7000	60			
W 86_64	64	37	14.1	300	0.70	850	7000	63	7.8	330	0.47	850	7000	58			
W 86_80	80	33	11.3	275	0.55	850	7000	59	6.3	305	0.38	850	7000	53			
W 86_100	100	29	9.0	250	0.43	850	7000	55	5.0	275	0.29	850	7000	49			

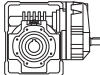
550 Nm

		i	η_s %	$n_1 = 2800 \text{ min}^{-1}$					$n_1 = 1400 \text{ min}^{-1}$								
				n_2 min ⁻¹	M_{n2} Nm	P_{n1} kW	R_{n1} N	R_{n2} N	η_d %	n_2 min ⁻¹	M_{n2} Nm	P_{n1} kW	R_{n1} N		R_{n2} N	η_d %	
WR 86	WR 86_21	21	70	133	270	4.3	500	4590	88	67	295	2.4	500	6070	85	189	
	WR 86_30	30	66	93	310	3.5	500	5410	86	47	345	2.1	500	7000	82		
	WR 86_45	45	59	62	355	2.8	500	6420	82	31	390	1.6	500	7000	78		
	WR 86_60	60	59	47	345	2.1	500	7000	81	23.3	380	1.2	500	7000	77		
	WR 86_69	69	57	41	345	1.8	500	7000	80	20.3	380	1.1	500	7000	75		
	WR 86_90	90	44	31	400	1.8	500	7000	73	15.6	440	1.1	500	7000	67		
	WR 86_120	120	44	23.3	355	1.2	500	7000	71	11.7	390	0.72	500	7000	66		
	WR 86_138	138	42	20.3	365	1.1	500	7000	69	10.1	405	0.68	500	7000	63		
	WR 86_168	168	38	16.7	325	0.86	500	7000	66	8.3	355	0.52	500	7000	60		
	WR 86_192	192	36	14.6	300	0.73	500	7000	63	7.3	330	0.43	500	7000	58		
	WR 86_240	240	32	11.7	275	0.57	500	7000	59	5.8	305	0.35	500	7000	53		
	WR 86_300	300	28	9.3	250	0.44	500	7000	55	4.7	275	0.27	500	7000	49		
					$n_1 = 900 \text{ min}^{-1}$					$n_1 = 500 \text{ min}^{-1}$							
	WR 86_21	21	70	43	325	1.8	500	7000	83	23.8	355	1.1	500	7000	81		189
	WR 86_30	30	66	30	375	1.5	500	7000	81	16.7	415	0.93	500	7000	78		
	WR 86_45	45	59	20.0	450	1.2	500	7000	76	11.1	500	0.80	500	7000	73		
	WR 86_60	60	59	15.0	430	0.90	500	7000	75	8.3	440	0.53	500	7000	72		
	WR 86_69	69	57	13.0	390	0.73	500	7000	73	7.2	400	0.43	500	7000	70		
	WR 86_90	90	44	10.0	500	0.82	500	7000	64	5.6	550	0.53	500	7000	60		
WR 86_120	120	44	7.5	440	0.55	500	7000	63	4.2	470	0.35	500	7000	59			
WR 86_138	138	42	6.5	430	0.48	500	7000	61	3.6	440	0.30	500	7000	56			
WR 86_168	168	38	5.4	390	0.38	500	7000	57	3.0	410	0.24	500	7000	53			
WR 86_192	192	36	4.7	390	0.35	500	7000	55	2.6	410	0.22	500	7000	50			
WR 86_240	240	32	3.8	310	0.24	500	7000	50	2.1	320	0.15	500	7000	46			
WR 86_300	300	28	3.0	310	0.22	500	7000	45	1.7	320	0.14	500	7000	41			



WR 86 - VF/W 44/86

500 Nm



i	η_s %	$n_1 = 2800 \text{ min}^{-1}$							$n_1 = 1400 \text{ min}^{-1}$							
		n_2 min ⁻¹	M_{n2} Nm	P_{n1} kW	R_{n1} N	R_{n2} N	η_d %	n_2 min ⁻¹	M_{n2} Nm	P_{n1} kW	R_{n1} N	R_{n2} N	η_d %			

WR 86_P90 B5	WR 86_15	15	66	187	275	6.1	—	4130	88	93	310	3.5	—	5410	86	189
	WR 86_22.5	22.5	59	124	315	4.8	—	4920	86	62	355	2.8	—	6420	82	
	WR 86_30	30	59	93	305	3.5	—	5720	85	47	345	2.1	—	7000	81	
	WR 86_34.5	34.5	57	81	305	3.1	—	6110	84	41	345	1.8	—	7000	80	
	WR 86_45	45	44	62	350	3.0	—	6640	77	31	400	1.8	—	7000	73	
	WR 86_60	60	44	47	315	2.0	—	7000	77	23.3	355	1.2	—	7000	71	
	WR 86_69	69	42	41	325	1.8	—	7000	75	20.3	365	1.1	—	7000	69	
	WR 86_84	84	38	33	285	1.4	—	7000	72	16.7	325	0.86	—	7000	66	
	WR 86_96	96	36	29.2	265	1.2	—	7000	70	14.6	300	0.73	—	7000	63	
	WR 86_120	120	32	23.3	240	0.88	—	7000	67	11.7	275	0.57	—	7000	59	
WR 86_150	150	28	18.7	220	0.69	—	7000	62	9.3	250	0.44	—	7000	55		
		$n_1 = 900 \text{ min}^{-1}$							$n_1 = 500 \text{ min}^{-1}$							
WR 86_15	15	66	60	345	2.6	—	6330	82	33	375	1.6	—	7000	81	189	
WR 86_22.5	22.5	59	40	390	2.1	—	7000	78	22.2	450	1.4	—	7000	76		
WR 86_30	30	59	30	380	1.6	—	7000	77	16.7	430	1.0	—	7000	75		
WR 86_34.5	34.5	57	26.1	380	1.4	—	7000	75	14.5	390	0.81	—	7000	73		
WR 86_45	45	44	20.0	440	1.4	—	7000	67	11.1	500	0.91	—	7000	64		
WR 86_60	60	44	15.0	390	0.93	—	7000	66	8.3	440	0.61	—	7000	63		
WR 86_69	69	42	13.0	405	0.88	—	7000	63	7.2	430	0.53	—	7000	61		
WR 86_84	84	38	10.7	355	0.66	—	7000	60	6.0	390	0.43	—	7000	57		
WR 86_96	96	36	9.4	330	0.56	—	7000	58	5.2	390	0.39	—	7000	55		
WR 86_120	120	32	7.5	305	0.45	—	7000	53	4.2	310	0.27	—	7000	50		
WR 86_150	150	28	6.0	275	0.35	—	7000	49	3.3	310	0.24	—	7000	46		

550 Nm



i	η_s %	$n_1 = 1400 \text{ min}^{-1}$							$n_1 = 900 \text{ min}^{-1}$							
		n_2 min ⁻¹	M_{n2} Nm	P_{n1} kW	R_{n1} N	R_{n2} N	η_d %	n_2 min ⁻¹	M_{n2} Nm	P_{n1} kW	R_{n1} N	R_{n2} N	η_d %			

VF/W 44/86	VF/W 44/86_230	230	38	6.1	500	0.59	220	7000	54	3.9	550	0.43	220	7000	53	190
	VF/W 44/86_300	300	30	4.7	500	0.54	220	7000	45	3.0	550	0.41	220	7000	42	
	VF/W 44/86_400	400	30	3.5	500	0.45	220	7000	41	2.3	550	0.32	220	7000	41	
	VF/W 44/86_525	525	25	2.7	500	0.33	220	7000	42	1.7	550	0.25	220	7000	39	
	VF/W 44/86_700	700	25	2.0	500	0.27	220	7000	39	1.3	550	0.20	220	7000	37	
	VF/W 44/86_920	920	22	1.5	500	0.20	220	7000	40	1.0	550	0.15	—	7000	37	
	VF/W 44/86_1380	1380	17	1.0	500	0.17	220	7000	32	0.65	550	0.13	—	7000	28	
	VF/W 44/86_1840	1840	17	0.76	500	0.13	220	7000	30	0.49	550	0.10	—	7000	28	
	VF/W 44/86_2116	2116	16	0.66	500	0.12	220	7000	28	0.43	550	0.09	220	7000	28	
	VF/W 44/86_2760	2760	14	0.51	500	0.11	—	7000	24	0.33	550	0.08	220	7000	24	

(-) Nehmen Sie bitte Kontakt mit unserem Applikationsdienst und Querkräften Daten an (Drehrichtung, Orientierung, Anordnung)

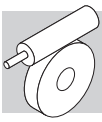

W 110 - WR 110

830 Nm

	i	η_s %	n_2	M_{n2}	P_{n1}	R_{n1}	R_{n2}	η_d	n_2	M_{n2}	P_{n1}	R_{n1}	R_{n2}	η_d		
			min ⁻¹	Nm	kW	N	N	%	min ⁻¹	Nm	kW	N	N	%		
			$n_1 = 2800 \text{ min}^{-1}$					$n_1 = 1400 \text{ min}^{-1}$								
W 110	W 110_7	7	71	400	445	20.7	1200	3710	90	200	500	11.8	1200	5020	89	188
	W 110_10	10	67	280	490	16.1	1200	4650	89	140	550	9.3	1200	6190	87	
	W 110_15	15	60	187	535	12.0	1200	5770	87	93	600	7.0	1200	7590	84	
	W 110_20	20	61	140	510	8.7	1200	6790	86	70	570	5.0	1200	8000	84	
	W 110_23	23	59	122	480	7.1	1200	7430	86	61	540	4.1	1200	8000	83	
	W 110_30	30	45	93	625	7.5	1200	7780	81	47	700	4.4	1200	8000	77	
	W 110_40	40	46	70	595	5.5	1200	8000	80	35	670	3.2	1200	8000	76	
	W 110_46	46	44	61	535	4.3	1200	8000	79	30	600	2.6	1200	8000	74	
	W 110_56	56	41	50	535	3.7	1200	8000	76	25.0	600	2.2	1200	8000	72	
	W 110_64	64	38	44	470	2.9	1200	8000	74	21.9	530	1.7	1200	8000	70	
W 110_80	80	34	35	420	2.2	1200	8000	71	17.5	470	1.3	1200	8000	66		
W 110_100	100	30	28.0	410	1.8	1200	8000	67	14.0	460	1.1	1200	8000	62		
			$n_1 = 900 \text{ min}^{-1}$					$n_1 = 500 \text{ min}^{-1}$								
W 110	W 110_7	7	71	129	540	8.3	1200	6040	88	71	595	5.2	1200	7680	86	188
	W 110_10	10	67	90	590	6.5	1200	7410	86	50	655	4.1	1200	8000	84	
	W 110_15	15	60	60	645	4.9	1200	8000	83	33	710	3.1	1200	8000	80	
	W 110_20	20	61	45	615	3.5	1200	8000	82	25.0	675	2.2	1200	8000	79	
	W 110_23	23	59	39	580	2.9	1200	8000	81	21.7	640	1.9	1200	8000	77	
	W 110_30	30	45	30	755	3.2	1200	8000	74	16.7	830	2.1	1200	8000	70	
	W 110_40	40	46	22.5	720	2.3	1200	8000	73	12.5	795	1.5	1200	8000	68	
	W 110_46	46	44	19.6	645	1.9	1200	8000	71	10.9	710	1.2	1200	8000	66	
	W 110_56	56	41	16.1	645	1.6	1200	8000	68	8.9	710	1.1	1200	8000	63	
	W 110_64	64	38	14.1	570	1.3	1200	8000	65	7.8	630	0.86	1200	8000	60	
W 110_80	80	34	11.3	505	0.98	1200	8000	61	6.3	560	0.65	1200	8000	56		
W 110_100	100	30	9.0	495	0.82	1200	8000	57	5.0	545	0.56	1200	8000	51		

1000 Nm

	i	η_s %	n_2	M_{n2}	P_{n1}	R_{n1}	R_{n2}	η_d	n_2	M_{n2}	P_{n1}	R_{n1}	R_{n2}	η_d		
			min ⁻¹	Nm	kW	N	N	%	min ⁻¹	Nm	kW	N	N	%		
			$n_1 = 2800 \text{ min}^{-1}$					$n_1 = 1400 \text{ min}^{-1}$								
WR 110	WR 110_21	21	70	133	540	8.6	700	5930	88	67	595	4.8	700	7950	86	189
	WR 110_30	30	66	93	590	6.7	700	7280	86	47	655	3.8	700	8000	84	
	WR 110_45	45	59	62	645	5.1	700	8000	83	31	710	2.9	700	8000	80	
	WR 110_60	60	60	47	615	3.7	700	8000	82	23.3	675	2.1	700	8000	79	
	WR 110_69	69	58	41	580	3.0	700	8000	81	20.3	640	1.8	700	8000	77	
	WR 110_90	90	44	31	755	3.3	700	8000	74	15.6	830	1.9	700	8000	70	
	WR 110_120	120	45	23.3	720	2.4	700	8000	73	11.7	795	1.4	700	8000	68	
	WR 110_138	138	43	20.3	645	1.9	700	8000	71	10.1	710	1.1	700	8000	66	
	WR 110_168	168	40	16.7	645	1.7	700	8000	68	8.3	710	0.98	700	8000	63	
	WR 110_192	192	37	14.6	570	1.3	700	8000	65	7.3	630	0.80	700	8000	60	
WR 110_240	240	33	11.7	505	1.0	700	8000	61	5.8	560	0.61	700	8000	56		
WR 110_300	300	29	9.3	495	0.85	700	8000	57	4.7	545	0.52	700	8000	51		
			$n_1 = 900 \text{ min}^{-1}$					$n_1 = 500 \text{ min}^{-1}$								
WR 110	WR 110_21	21	70	43	645	3.4	700	8000	84	23.8	715	2.2	700	8000	82	189
	WR 110_30	30	66	30	710	2.8	700	8000	81	16.7	785	1.7	700	8000	79	
	WR 110_45	45	59	20.0	870	2.4	700	8000	77	11.1	950	1.5	700	8000	75	
	WR 110_60	60	60	15.0	800	1.6	700	8000	77	8.3	850	1.0	700	8000	74	
	WR 110_69	69	58	13.0	750	1.4	700	8000	75	7.2	820	0.86	700	8000	72	
	WR 110_90	90	44	10.0	900	1.4	700	8000	66	5.6	1000	0.94	700	8000	62	
	WR 110_120	120	45	7.5	870	1.1	700	8000	65	4.2	950	0.68	700	8000	61	
	WR 110_138	138	43	6.5	800	0.87	700	8000	63	3.6	900	0.58	700	8000	59	
	WR 110_168	168	40	5.4	775	0.72	700	8000	60	3.0	800	0.45	700	8000	55	
	WR 110_192	192	37	4.7	685	0.59	700	8000	57	2.6	720	0.37	700	8000	53	
WR 110_240	240	33	3.8	590	0.44	700	8000	53	2.1	620	0.28	700	8000	48		
WR 110_300	300	29	3.0	570	0.37	700	8000	48	1.7	600	0.24	700	8000	44		

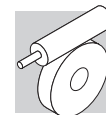

VF/W 49/110

1050 Nm



	i	η_s %	$n_1 = 1400 \text{ min}^{-1}$						$n_1 = 900 \text{ min}^{-1}$							
			n_2 min ⁻¹	M_{n2} Nm	P_{n1} kW	R_{n1} N	R_{n2} N	η_d %	n_2 min ⁻¹	M_{n2} Nm	P_{n1} kW	R_{n1} N	R_{n2} N		η_d %	
VF/W 49/110	VF/W 49/110_230	230	38	6.1	1000	1.2	400	8000	52	3.9	1050	0.84	400	8000	51	190
	VF/W 49/110_300	300	29	4.7	1000	1.0	400	8000	48	3.0	1050	0.70	400	8000	47	
	VF/W 49/110_400	400	30	3.5	1000	0.81	400	8000	45	2.3	1050	0.55	400	8000	45	
	VF/W 49/110_540	540	25	2.6	1000	0.66	400	8000	41	1.7	1050	0.48	400	8000	38	
	VF/W 49/110_720	720	24	1.9	1000	0.51	400	8000	40	1.3	1050	0.36	400	8000	38	
	VF/W 49/110_1080	1080	18	1.3	1000	0.44	400	8000	31	0.83	1050	0.28	400	8000	30	
	VF/W 49/110_1350	1350	16	1.0	1000	0.36	400	8000	30	0.67	1050	0.26	400	8000	28	
	VF/W 49/110_1656	1656	17	0.85	1000	0.30	400	8000	30	0.54	1050	0.20	400	8000	30	
	VF/W 49/110_2070	2070	15	0.68	1000	0.25	400	8000	28	0.43	1050	0.19	400	8000	25	
	VF/W 49/110_2800	2800	13	0.50	1000	0.22	400	8000	24	0.32	1050	0.17	400	8000	21	

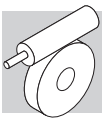

VF 130 - VFR 130

1500 Nm

										n_2	M_{n2}	P_{n1}	R_{n1}	R_{n2}		η_d	n_2	M_{n2}	P_{n1}	R_{n1}	R_{n2}	η_d
										min ⁻¹	Nm	kW	N	N		%	min ⁻¹	Nm	kW	N	N	%
										$n_1 = 2800 \text{ min}^{-1}$					$n_1 = 1400 \text{ min}^{-1}$							
VF 130	VF 130_7	7	71	400	555	25	1500	4930	91	200	740	17.4	1500	5990	89	188						
	VF 130_10	10	67	280	593	19.3	1500	6210	90	140	790	13.3	1500	7620	88							
	VF 130_15	15	63	187	690	15.3	1500	7390	88	93	920	10.6	1500	9100	86							
	VF 130_20	20	59	140	675	11.4	1500	8670	87	70	900	8.0	1500	10700	84							
	VF 130_23	23	57	122	668	9.9	1500	9300	86	61	890	6.9	1500	11500	83							
	VF 130_30	30	49	93	788	9.3	1040	10100	83	47	1050	6.6	—	12500	79							
	VF 130_40	40	44	70	825	7.6	—	11400	80	35	1100	5.4	—	12600	76							
	VF 130_46	46	45	61	788	6.3	1290	12200	80	30.0	1050	4.5	—	12600	76							
	VF 130_56	56	42	50	720	4.8	1500	12600	78	25.0	960	3.4	940	12600	73							
	VF 130_64	64	39	44	698	4.2	1500	12600	76	21.9	930	3.0	1220	12600	71							
	VF 130_80	80	35	35	660	3.3	1500	12600	73	17.5	880	2.4	1500	12600	68							
VF 130_100	100	31	28	585	2.5	1500	12600	70	14.0	780	1.8	1500	12600	64								
										$n_1 = 900 \text{ min}^{-1}$					$n_1 = 500 \text{ min}^{-1}$							
VF 130	VF 130_7	7	71	129	850	13.0	1500	6980	88	71	1000	8.8	1500	8670	86	188						
	VF 130_10	10	67	90	900	9.9	1500	8900	87	50	1100	6.9	1500	10800	84							
	VF 130_15	15	63	60	1080	8.1	1500	10490	84	33	1350	5.9	1500	12600	81							
	VF 130_20	20	59	45	1050	6.1	1500	12400	82	25.0	1350	4.6	1500	13800	79							
	VF 130_23	23	57	39	1050	5.4	1500	13200	81	21.7	1300	3.9	1500	13800	77							
	VF 130_30	30	49	30.0	1250	5.2	—	13200	77	16.7	1500	3.7	—	13800	72							
	VF 130_40	40	44	22.5	1200	3.9	—	13200	73	12.5	1400	2.8	—	13800	68							
	VF 130_46	46	45	19.6	1150	3.3	490	13200	73	10.9	1350	2.3	1270	13800	68							
	VF 130_56	56	42	16.1	1080	2.7	1500	13200	70	8.9	1200	1.8	1500	13800	65							
	VF 130_64	64	39	14.1	1050	2.4	1500	13200	68	7.8	1200	1.6	1500	13800	62							
	VF 130_80	80	35	11.3	950	1.8	1500	13200	64	6.3	1150	1.3	1500	13800	58							
VF 130_100	100	31	9.0	800	1.3	1500	13200	59	5.0	900	0.91	1500	13800	54								

1800 Nm

										n_2	M_{n2}	P_{n1}	R_{n1}	R_{n2}		η_d	n_2	M_{n2}	P_{n1}	R_{n1}	R_{n2}	η_d
										min ⁻¹	Nm	kW	N	N		%	min ⁻¹	Nm	kW	N	N	%
										$n_1 = 2800 \text{ min}^{-1}$					$n_1 = 1400 \text{ min}^{-1}$							
VFR 130	VFR 130_60	60	58	47	1050	6.4	1000	12400	81	23.3	1350	4.3	1000	13800	78	189						
	VFR 130_69	69	56	41	1050	5.6	1000	13200	80	20.3	1300	3.7	1000	13800	76							
	VFR 130_90	90	48	31	1250	5.4	1000	13200	76	15.6	1500	3.5	1000	13800	71							
	VFR 130_120	120	43	23.3	1200	4.1	1000	13200	72	11.7	1400	2.6	1000	13800	67							
	VFR 130_138	138	44	20.3	1150	3.4	1000	13200	72	10.1	1350	2.2	1000	13800	67							
	VFR 130_168	168	41	16.7	1080	2.7	1000	13200	69	8.3	1200	1.6	1000	13800	64							
	VFR 130_192	192	38	14.6	1050	2.4	1000	13200	67	7.3	1200	1.5	1000	13800	61							
	VFR 130_240	240	34	11.7	950	1.9	1000	13200	63	5.8	1150	1.2	1000	13800	57							
	VFR 130_300	300	30	9.3	800	1.4	1000	13200	58	4.7	900	0.83	1000	13800	53							
										$n_1 = 900 \text{ min}^{-1}$					$n_1 = 500 \text{ min}^{-1}$							
VFR 130	VFR 130_60	60	58	15.0	1450	3.1	1000	13800	75	8.3	1600	1.9	1000	13800	74	189						
	VFR 130_69	69	56	13.0	1450	2.7	1000	13800	74	7.2	1550	1.6	1000	13800	72							
	VFR 130_90	90	48	10.0	1600	2.5	1000	13800	68	5.6	1800	1.6	1000	13800	66							
	VFR 130_120	120	43	7.5	1600	2.0	1000	13800	63	4.2	1800	1.3	1000	13800	61							
	VFR 130_138	138	44	6.5	1500	1.6	1000	13800	64	3.6	1600	1.0	1000	13800	61							
	VFR 130_168	168	41	5.4	1350	1.3	1000	13800	60	3.0	1450	0.78	1000	13800	58							
	VFR 130_192	192	38	4.7	1300	1.1	1000	13800	58	2.6	1400	0.70	1000	13800	55							
	VFR 130_240	240	34	3.8	1200	0.87	1000	13800	54	2.1	1250	0.54	1000	13800	51							
	VFR 130_300	300	30	3.0	1000	0.64	1000	13800	49	1.7	1100	0.41	1000	13800	47							

(-) Nehmen Sie bitte Kontakt mit unserem Applikationsdienst und Querkräften an (Drehrichtung, Orientierung, Anordnung)

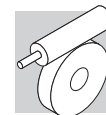

W/VF 63/130

1850 Nm



		i	η _s %	n ₁ = 1400 min ⁻¹						n ₁ = 900 min ⁻¹						
				n ₂ min ⁻¹	M _{n2} Nm	P _{n1} kW	R _{n1} N	R _{n2} N	η _d %	n ₂ min ⁻¹	M _{n2} Nm	P _{n1} kW	R _{n1} N	R _{n2} N	η _d %	
				W/VF 63/130	W/VF 63/130_280	280	31	5.0	1800	1.9	480	13800	50	3.2	1850	
W/VF 63/130_400	400	29	3.5	1800	1.5	480	13800	44	2.3	1850	0.99	480	13800	44		
W/VF 63/130_600	600	26	2.3	1800	1.1	480	13800	40	1.5	1850	0.73	480	13800	40		
W/VF 63/130_760	760	24	1.8	1800	0.89	480	13800	39	1.2	1850	0.62	480	13800	37		
W/VF 63/130_960	960	23	1.5	1800	0.74	480	13800	37	0.94	1850	0.52	480	13800	35		
W/VF 63/130_1200	1200	19	1.2	1800	0.65	—	13800	34	0.75	1850	0.45	—	13800	32		
W/VF 63/130_1520	1520	18	0.92	1800	0.55	—	13800	32	0.59	1850	0.38	—	13800	30		
W/VF 63/130_1800	1800	16	0.78	1800	0.52	—	13800	28	0.50	1850	0.37	—	13800	26		
W/VF 63/130_2560	2560	14	0.55	1800	0.45	—	13800	23	0.35	1850	0.32	—	13800	21		
W/VF 63/130_3200	3200	12	0.44	1800	0.49	—	13800	17	0.28	1850	0.34	480	13800	16		

(-) Nehmen Sie bitte Kontakt mit unserem Applikationsdienst und Querkraftsdaten angeben (Drehrichtung, Orientierung, Anordnung)

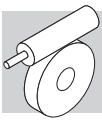

VF 150 - VFR 150

2000 Nm

			i	η_s %	$n_1 = 2800 \text{ min}^{-1}$					$n_1 = 1400 \text{ min}^{-1}$							
					n_2 min ⁻¹	M_{n2} Nm	P_{n1} kW	R_{n1} N	R_{n2} N	η_d %	n_2 min ⁻¹	M_{n2} Nm	P_{n1} kW	R_{n1} N		R_{n2} N	η_d %
VF 150	VF 150_7	7	72	400	750	35	2200	5010	91	200	1000	24	2200	6040	90	188	
	VF 150_10	10	68	280	788	25	2200	6630	90	140	1050	17.5	2200	8120	88		
	VF 150_15	15	64	187	863	19.0	2200	8110	89	93	1150	13.1	2200	9990	87		
	VF 150_20	20	59	140	975	16.4	2200	9170	87	70	1300	11.3	2200	11300	84		
	VF 150_23	23	57	122	953	14.1	2200	9940	86	61	1270	9.8	2200	12300	83		
	VF 150_30	30	48	93	1028	12.1	2200	11100	83	47	1370	8.5	2200	13700	80		
	VF 150_40	40	44	70	1155	10.5	2200	12300	81	35	1540	7.4	830	14700	77		
	VF 150_46	46	45	61	1163	9.2	2200	13100	81	30.0	1550	6.5	1400	14700	77		
	VF 150_56	56	42	50	1028	6.8	2200	14600	79	25.0	1370	4.9	2200	14700	74		
	VF 150_64	64	39	44	998	5.9	2200	14700	77	21.9	1330	4.2	2200	14700	72		
	VF 150_80	80	35	35	938	4.6	2200	14700	74	17.5	1250	3.4	2200	14700	69		
VF 150_100	100	31	28	863	3.6	2200	14700	71	14.0	1150	2.6	2200	14700	65			
					$n_1 = 900 \text{ min}^{-1}$					$n_1 = 500 \text{ min}^{-1}$							
VF 150	VF 150_7	7	72	129	1150	17.6	2200	7040	89	71	1400	12.2	2200	8560	87	188	
	VF 150_10	10	68	90	1200	13.0	2200	9480	87	50	1500	9.4	2200	11400	85		
	VF 150_15	15	64	60	1350	10.0	2200	11500	85	33	1700	7.3	2200	13800	83		
	VF 150_20	20	59	45	1500	8.6	2200	13100	83	25.0	1900	6.4	2200	15700	80		
	VF 150_23	23	57	39	1500	7.6	2200	14200	82	21.7	1850	5.5	2200	16000	78		
	VF 150_30	30	48	30.0	1600	6.5	2200	15500	77	16.7	1950	4.8	2200	16000	73		
	VF 150_40	40	44	22.5	1750	5.6	1150	15500	74	12.5	2000	3.9	2200	16000	69		
	VF 150_46	46	45	19.6	1750	4.9	2100	15500	74	10.9	2000	3.4	2200	16000	69		
	VF 150_56	56	42	16.1	1500	3.7	2200	15500	71	8.9	1750	2.6	2200	16000	66		
	VF 150_64	64	39	14.1	1450	3.2	2200	15500	69	7.8	1700	2.3	2200	16000	63		
	VF 150_80	80	35	11.3	1350	2.5	2200	15500	65	6.3	1550	1.8	2200	16000	59		
VF 150_100	100	31	9.0	1150	1.8	2200	15500	61	5.0	1300	1.3	2200	16000	55			

2600 Nm

			i	η_s %	$n_1 = 2800 \text{ min}^{-1}$					$n_1 = 1400 \text{ min}^{-1}$							
					n_2 min ⁻¹	M_{n2} Nm	P_{n1} kW	R_{n1} N	R_{n2} N	η_d %	n_2 min ⁻¹	M_{n2} Nm	P_{n1} kW	R_{n1} N		R_{n2} N	η_d %
VFR 150	VFR 150_45	45	63	62	1350	10.6	1500	11600	84	31	1700	6.8	1500	14600	82	189	
	VFR 150_60	60	58	47	1500	9.0	1500	13100	82	23.3	1900	5.9	1500	16000	79		
	VFR 150_69	69	56	41	1500	7.9	1500	14100	81	20.3	1850	5.1	1500	16000	77		
	VFR 150_90	90	47	31	1600	6.9	1500	15500	76	15.6	1950	4.4	1500	16000	72		
	VFR 150_120	120	43	23.3	1750	5.9	1500	15500	73	11.7	2000	3.6	1500	16000	68		
	VFR 150_138	138	44	20.3	1750	5.1	1500	15500	73	10.1	2000	3.1	1500	16000	68		
	VFR 150_168	168	41	16.7	1500	3.8	1500	15500	70	8.3	1750	2.4	1500	16000	65		
	VFR 150_192	192	38	14.6	1450	3.3	1500	15500	68	7.3	1700	2.1	1500	16000	62		
	VFR 150_240	240	34	11.7	1350	2.6	1500	15500	64	5.8	1550	1.6	1500	16000	58		
	VFR 150_300	300	30	9.3	1150	1.9	1500	15500	60	4.7	1300	1.2	1500	16000	54		
						$n_1 = 900 \text{ min}^{-1}$					$n_1 = 500 \text{ min}^{-1}$						
VFR 150	VFR 150_45	45	63	20.0	1950	5.2	1500	16000	79	11.1	2100	3.2	1500	16000	78	189	
	VFR 150_60	60	58	15.0	2100	4.4	1500	16000	76	8.3	2300	2.7	1500	16000	74		
	VFR 150_69	69	56	13.0	2050	3.8	1500	16000	74	7.2	2200	2.3	1500	16000	72		
	VFR 150_90	90	47	10.0	2200	3.4	1500	16000	69	5.6	2400	2.1	1500	16000	66		
	VFR 150_120	120	43	7.5	2300	2.8	1500	16000	64	4.2	2600	1.8	1500	16000	62		
	VFR 150_138	138	44	6.5	2200	2.4	1500	16000	64	3.6	2400	1.5	1500	16000	62		
	VFR 150_168	168	41	5.4	1950	1.8	1500	16000	61	3.0	2100	1.1	1500	16000	59		
	VFR 150_192	192	38	4.7	1900	1.6	1500	16000	59	2.6	2000	1.0	1500	16000	56		
	VFR 150_240	240	34	3.8	1700	1.2	1500	16000	54	2.1	1800	0.76	1500	16000	52		
	VFR 150_300	300	30	3.0	1350	0.85	1500	16000	50	1.7	1450	0.54	1500	16000	47		

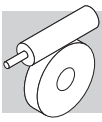

VF 185 - VFR 185

3600 Nm

			i	η_s %	$n_1 = 2800 \text{ min}^{-1}$					$n_1 = 1400 \text{ min}^{-1}$							
					n_2 min ⁻¹	M_{n2} Nm	P_{n1} kW	R_{n1} N	R_{n2} N	η_d %	n_2 min ⁻¹	M_{n2} Nm	P_{n1} kW	R_{n1} N		R_{n2} N	η_d %
VF 185	VF 185_7	7	72	400	1313	60	2800	4670	91	200	1750	41	2800	5570	90	188	
	VF 185_10	10	68	280	1365	44	2800	7390	90	140	1820	30	2800	8960	89		
	VF 185_15	15	66	187	1388	30	2800	9460	89	93	1850	21	2800	11600	88		
	VF 185_20	20	59	140	1703	28	2800	10500	88	70	2270	19.6	2800	12900	85		
	VF 185_30	30	54	93	1485	16.9	2800	13700	86	47	1980	11.8	2800	16900	83		
	VF 185_40	40	44	70	1973	17.6	—	14500	82	35	2630	12.4	—	17900	78		
	VF 185_50	50	41	56	1875	13.7	—	16300	80	28.0	2500	9.8	—	18000	76		
	VF 185_60	60	39	47	1703	10.7	2800	18000	78	23.3	2270	7.6	770	18000	74		
	VF 185_80	80	33	35	1590	7.8	2800	18000	75	17.5	2120	5.6	1140	18000	69		
	VF 185_100	100	30	28.0	1425	5.8	2800	18000	72	14.0	1900	4.3	2800	18000	65		
					$n_1 = 900 \text{ min}^{-1}$					$n_1 = 500 \text{ min}^{-1}$							
VF 185	VF 185_7	7	72	129	2000	30	2800	7120	89	71	2450	21	2800	8730	88	188	
	VF 185_10	10	68	90	2150	23	2800	10200	88	50	2600	16.0	2800	12500	86		
	VF 185_15	15	66	60	2250	16.4	2800	13100	86	33	2800	11.8	2800	15700	84		
	VF 185_20	20	59	45	2750	15.6	2800	14600	84	25.0	3300	10.9	2800	17900	81		
	VF 185_30	30	54	30.0	2400	9.4	2800	19000	81	16.7	2800	6.5	2800	19500	77		
	VF 185_40	40	44	22.5	3100	9.7	—	19000	76	12.5	3600	6.8	—	19500	71		
	VF 185_50	50	41	18.0	2900	7.6	—	19000	73	10.0	3300	5.2	—	19500	68		
	VF 185_60	60	39	15.0	2600	5.8	700	19000	71	8.3	3000	4.2	2800	19500	66		
	VF 185_80	80	33	11.3	2400	4.3	1770	19000	66	6.3	2800	3.2	2800	19500	60		
	VF 185_100	100	30	9.0	2000	3.0	2800	19000	62	5.0	2300	2.1	2800	19500	56		

4200 Nm

			i	η_s %	$n_1 = 2800 \text{ min}^{-1}$					$n_1 = 1400 \text{ min}^{-1}$								
					n_2 min ⁻¹	M_{n2} Nm	P_{n1} kW	R_{n1} N	R_{n2} N	η_d %	n_2 min ⁻¹	M_{n2} Nm	P_{n1} kW	R_{n1} N		R_{n2} N	η_d %	
VFR 185	VFR 185_90	90	53	31	2400	9.9	1700	19000	80	15.6	2800	6.0	1700	19500	76	189		
	VFR 185_120	120	43	23.3	3100	10.2	1700	19000	75	11.7	3600	6.3	1700	19500	70			
	VFR 185_150	150	40	18.7	2900	7.9	1700	19000	72	9.3	3300	4.8	1700	19500	67			
	VFR 185_180	180	38	15.6	2600	6.1	1700	19000	70	7.8	3000	3.8	1700	19500	65			
	VFR 185_240	240	32	11.7	2400	4.5	1700	19000	65	5.8	2800	2.9	1700	19500	59			
	VFR 185_300	300	29	9.3	2000	3.2	1700	19000	61	4.7	2300	2.0	1700	19500	55			
						$n_1 = 900 \text{ min}^{-1}$					$n_1 = 500 \text{ min}^{-1}$							
	VFR 185	VFR 185_90	90	53	10.0	3200	4.6	1700	19500	73	5.6	3500	2.9	1700	19500		71	189
		VFR 185_120	120	43	7.5	3800	4.5	1700	19500	66	4.2	4200	2.9	1700	19500		63	
		VFR 185_150	150	40	6.0	3400	3.4	1700	19500	63	3.3	3700	2.2	1700	19500		60	
VFR 185_180		180	38	5.0	3300	2.9	1700	19500	60	2.8	3600	1.8	1700	19500	57			
VFR 185_240		240	32	3.8	2800	2.0	1700	19500	54	2.1	2900	1.2	1700	19500	53			
VFR 185_300		300	29	3.0	2400	1.5	1700	19500	50	1.7	2500	0.91	1700	19500	48			

(-) Nehmen Sie bitte Kontakt mit unserem Applikationsdienst und Querkraftsdaten angeben (Drehrichtung, Orientierung, Anordnung)



W/VF 86/185

4400 Nm



	i	η_s %	$n_1 = 1400 \text{ min}^{-1}$							$n_1 = 900 \text{ min}^{-1}$					
			n_2 min ⁻¹	M_{n2} Nm	P_{n1} kW	R_{n1} N	R_{n2} N	η_d %	n_2 min ⁻¹	M_{n2} Nm	P_{n1} kW	R_{n1} N	R_{n2} N	η_d %	
			W/VF 86/185												
W/VF 86/185_280	280	31	5.0	4200	4.2	850	19500	52	3.2	4400	3.0	850	19500	49	
W/VF 86/185_400	400	29	3.5	4200	3.2	850	19500	48	2.3	4400	2.3	850	19500	45	
W/VF 86/185_600	600	26	2.3	4200	2.3	850	19500	45	1.5	4400	1.6	850	19500	43	
W/VF 86/185_800	800	26	1.8	4200	1.8	850	19500	43	1.1	4400	1.3	850	19500	40	
W/VF 86/185_920	920	26	1.5	4200	1.6	850	19500	42	1.0	4400	1.2	850	19500	38	
W/VF 86/185_1200	1200	20	1.2	4200	1.5	850	19500	34	0.75	4400	0.99	850	19500	35	
W/VF 86/185_1600	1600	20	0.88	4200	1.1	850	19500	35	0.56	4400	0.79	850	19500	33	
W/VF 86/185_1840	1840	19	0.76	4200	0.98	850	19500	34	0.49	4400	0.70	850	19500	32	
W/VF 86/185_2560	2560	16	0.55	4200	0.83	850	19500	29	0.35	4400	0.60	850	19500	27	
W/VF 86/185_3200	3200	15	0.44	4200	0.80	850	19500	24	0.28	4400	0.59	850	19500	22	



VF 210 - VFR 210

5000 Nm

			i	η_s %	$n_1 = 2800 \text{ min}^{-1}$					$n_1 = 1400 \text{ min}^{-1}$							
					n_2 min ⁻¹	M_{n2} Nm	P_{n1} kW	R_{n1} N	R_{n2} N	η_d %	n_2 min ⁻¹	M_{n2} Nm	P_{n1} kW	R_{n1} N		R_{n2} N	η_d %
VF 210	VF 210_7	7	71	400	1725	79	5300	14000	91	200	2300	54	5300	16700	90	188	
	VF 210_10	10	69	280	1988	65	5300	16300	90	140	2650	44	5300	19500	89		
	VF 210_15	15	63	187	2138	47	5300	19700	89	93	2850	32	5300	23700	88		
	VF 210_20	20	57	140	2325	39	4970	22000	87	70	3100	27	1100	26600	85		
	VF 210_30	30	51	93	2288	26	5300	25900	85	47	3050	18.5	1760	31500	83		
	VF 210_40	40	42	70	2625	23	—	28300	81	35	3500	17.0	—	31500	78		
	VF 210_50	50	39	56	2475	18.4	—	31000	79	28.0	3300	13.0	—	31500	76		
	VF 210_60	60	36	47	2363	15.0	—	31500	77	23.3	3015	10.0	—	31500	73		
	VF 210_80	80	31	35	2175	10.9	—	31500	73	17.5	2900	7.7	—	31500	69		
	VF 210_100	100	27	28	2025	8.5	950	31500	70	14.0	2700	6.0	—	31500	65		
					$n_1 = 900 \text{ min}^{-1}$					$n_1 = 500 \text{ min}^{-1}$							
VF 210	VF 210_7	7	71	129	2700	41	5300	18800	89	71	3400	29	5300	21800	88	188	
	VF 210_10	10	69	90	3150	34	5300	21900	88	50	3800	23	5300	26000	87		
	VF 210_15	15	63	60	3300	24	5300	27000	86	33	4100	17.2	5300	31800	84		
	VF 210_20	20	57	45	3800	22	—	29900	83	25.0	4700	15.4	—	34500	81		
	VF 210_30	30	51	30.0	3400	13.4	3750	33000	80	16.7	4000	9.3	5300	34500	77		
	VF 210_40	40	42	22.5	4300	13.5	—	33000	75	12.5	5000	9.4	—	34500	71		
	VF 210_50	50	39	18.0	4000	10.5	—	33000	72	10.0	4500	7.1	—	34500	68		
	VF 210_60	60	36	15.0	3720	8.5	—	33000	70	8.3	4300	6.0	—	34500	65		
	VF 210_80	80	31	11.3	3300	6.0	—	33000	65	6.3	3900	4.4	—	34500	60		
	VF 210_100	100	27	9.0	3000	4.6	—	33000	61	5.0	3400	3.4	1470	34500	56		

6300 Nm

			i	η_s %	$n_1 = 2800 \text{ min}^{-1}$					$n_1 = 1400 \text{ min}^{-1}$							
					n_2 min ⁻¹	M_{n2} Nm	P_{n1} kW	R_{n1} N	R_{n2} N	η_d %	n_2 min ⁻¹	M_{n2} Nm	P_{n1} kW	R_{n1} N		R_{n2} N	η_d %
VFR 210	VFR 210_30	30	68	93	3150	36	1800	22100	87	47	3800	21.8	2200	27400	86	189	
	VFR 210_45	45	62	62	3300	25	1800	27000	85	31	4100	16.2	2200	33200	83		
	VFR 210_60	60	56	47	3800	22	1800	29900	82	23.0	4700	14.5	2200	34500	80		
	VFR 210_90	90	50	31	3400	14.1	1800	33000	79	15.6	4000	8.6	2200	34500	76		
	VFR 210_120	120	41	23.3	4300	14.3	1800	33000	74	11.7	5000	8.8	2200	34500	70		
	VFR 210_150	150	38	18.7	4000	11.1	1800	33000	71	9.3	4500	6.6	2200	34500	67		
	VFR 210_180	180	35	15.6	3720	8.8	1800	33000	69	7.8	4300	5.5	2200	34500	64		
	VFR 210_240	240	30	11.7	3300	6.3	1800	33000	64	5.8	3900	4.1	2200	34500	59		
	VFR 210_300	300	26	9.3	3000	4.9	1800	33000	60	4.7	3400	3.0	2200	34500	55		
						$n_1 = 900 \text{ min}^{-1}$					$n_1 = 500 \text{ min}^{-1}$						
VFR 210	VFR 210_30	30	68	30.0	4800	18.1	2300	30100	84	16.7	5500	11.8	2650	34500	82	189	
	VFR 210_45	45	62	20.0	4900	12.9	2300	34500	80	11.1	5600	8.4	2650	34500	78		
	VFR 210_60	60	56	15.0	5400	11.1	2300	34500	77	8.3	6000	7.1	2650	34500	74		
	VFR 210_90	90	50	10.0	4600	6.7	2300	34500	72	5.6	5150	4.3	2650	34500	70		
	VFR 210_120	120	41	7.5	5900	7.1	2300	34500	66	4.2	6300	4.4	2650	34500	63		
	VFR 210_150	150	38	6.0	5300	5.4	2300	34500	62	3.3	5900	3.5	2650	34500	59		
	VFR 210_180	180	35	5.0	4900	4.4	2300	34500	59	2.8	5400	2.8	2650	34500	56		
	VFR 210_240	240	30	3.8	4400	3.2	2300	34500	54	2.1	4800	2.1	2650	34500	50		
VFR 210_300	300	26	3.0	3600	2.3	2300	34500	49	1.7	4000	1.5	2650	34500	46			

(-) Nehmen Sie bitte Kontakt mit unserem Applikationsdienst und Querkraftsdaten angeben (Drehrichtung, Orientierung, Anordnung)



VF/VF 130/210

6500 Nm

		i	η _s %	n ₁ = 1400 min ⁻¹					n ₁ = 900 min ⁻¹							
				n ₂ min ⁻¹	M _{n2} Nm	P _{n1} kW	R _{n1} N	R _{n2} N	η _d %	n ₂ min ⁻¹	M _{n2} Nm	P _{n1} kW	R _{n1} N		R _{n2} N	η _d %
VF/VF 130/210	VF/VF 130/210_280	280	30	5.0	6300	6.3	1500	34500	52	3.2	6500	4.4	1500	34500	50	190
	VF/VF 130/210_400	400	28	3.5	6300	4.6	1500	34500	50	2.3	6500	3.2	1500	34500	48	
	VF/VF 130/210_600	600	26	2.3	6300	3.6	1500	34500	43	1.5	6500	2.4	1500	34500	43	
	VF/VF 130/210_800	800	25	1.8	6300	2.8	1500	34500	41	1.1	6500	2.0	1500	34500	38	
	VF/VF 130/210_920	920	24	1.5	6300	2.7	1500	34500	37	1.0	6500	1.9	1500	34500	35	
	VF/VF 130/210_1200	1200	21	1.2	6300	2.2	—	34500	35	0.75	6500	1.5	—	34500	34	
	VF/VF 130/210_1600	1600	18	0.88	6300	1.8	—	34500	32	0.56	6500	1.2	—	34500	32	
	VF/VF 130/210_1840	1840	19	0.76	6300	1.7	—	34500	30	0.49	6500	1.2	490	34500	28	
	VF/VF 130/210_2560	2560	16	0.55	6300	1.5	1220	34500	24	0.35	6500	1.0	1500	34500	24	
	VF/VF 130/210_3200	3200	15	0.44	6300	1.3	1500	34500	22	0.28	6500	0.96	1500	34500	20	

(-) Nehmen Sie bitte Kontakt mit unserem Applikationsdienst und Querkräften an (Drehrichtung, Orientierung, Anordnung)



VF 250 - VFR 250

7100 Nm

				n ₁ = 2800 min ⁻¹					n ₁ = 1400 min ⁻¹							
				n ₂	M _{n2}	P _{n1}	R _{n1}	R _{n2}	η _d	n ₂	M _{n2}	P _{n1}	R _{n1}		R _{n2}	η _d
				min ⁻¹	Nm	kW	N	N	%	min ⁻¹	Nm	kW	N		N	%
VF 250	VF 250_7	7	71	400	2400	109	7000	18300	92	200	3200	75	7000	21900	91	188
	VF 250_10	10	69	280	2775	89	7000	21100	91	140	3700	61	7000	25300	90	
	VF 250_15	15	64	187	3000	65	7000	25100	90	93	4000	45	7000	30300	88	
	VF 250_20	20	59	140	3338	56	7000	28000	88	70	4450	38	7000	33900	86	
	VF 250_30	30	53	93	3000	34	7000	33400	86	47	4000	23	7000	40600	84	
	VF 250_40	40	41	70	3600	32	4680	36200	82	35	4800	22	—	44000	79	
	VF 250_50	50	36	56	3375	25	6370	39500	79	28.0	4500	17.0	—	47000	76	
	VF 250_60	60	38	47	3375	20.6	7000	42100	80	23.3	4500	15.0	—	47000	76	
	VF 250_80	80	32	35	2925	14.1	7000	47000	76	17.5	3900	10.0	—	47000	71	
	VF 250_100	100	29	28	2738	11.0	7000	47000	73	14.0	3650	7.8	3010	47000	68	
				n ₁ = 900 min ⁻¹					n ₁ = 500 min ⁻¹							
VF 250	VF 250_7	7	71	129	4150	63	7000	23700	90	71	5200	44	7000	27600	88	188
	VF 250_10	10	69	90	4800	51	7000	27600	89	50	6000	36	7000	32300	87	
	VF 250_15	15	64	60	5300	39	7000	33200	87	33	6400	27	7000	39500	85	
	VF 250_20	20	59	45	5950	33	1640	37200	85	25.0	7100	24	1910	44400	82	
	VF 250_30	30	53	30.0	5500	21	7000	44900	81	16.7	6000	14.7	7000	52000	79	
	VF 250_40	40	41	22.5	6500	20.0	—	48800	76	12.5	7000	13.6	—	52000	72	
	VF 250_50	50	36	18.0	6200	16.2	—	50000	73	10.0	6500	11.1	—	52000	68	
	VF 250_60	60	38	15.0	5600	12.2	—	50000	72	8.3	6300	8.6	4350	52000	68	
	VF 250_80	80	32	11.3	5200	9.3	—	50000	67	6.3	5400	6.8	7000	52000	62	
	VF 250_100	100	29	9.0	4800	7.2	3010	50000	63	5.0	5000	5.3	4160	52000	58	

9000 Nm

				n ₁ = 2800 min ⁻¹					n ₁ = 1400 min ⁻¹							
				n ₂	M _{n2}	P _{n1}	R _{n1}	R _{n2}	η _d	n ₂	M _{n2}	P _{n1}	R _{n1}		R _{n2}	η _d
				min ⁻¹	Nm	kW	N	N	%	min ⁻¹	Nm	kW	N		N	%
VFR 250	VFR 250_30	30	68	93	4800	54	2800	27800	89	47	6000	34	3500	34000	86	189
	VFR 250_45	45	63	62	5300	41	2800	33300	87	31	6400	25	3500	41300	84	
	VFR 250_60	60	58	47	5950	35	2800	37200	85	23.0	7100	21	3500	46100	81	
	VFR 250_90	90	52	31	5500	22	2800	44700	81	15.6	6000	12.6	3500	52000	78	
	VFR 250_120	120	40	23.3	6500	21.3	2800	48500	76	11.7	7000	12.1	3500	52000	71	
	VFR 250_150	150	35	18.7	6200	16.9	2800	50000	73	9.3	6500	9.5	3500	52000	67	
	VFR 250_180	180	37	15.6	5600	12.9	2800	50000	72	7.8	6300	7.7	3500	52000	67	
	VFR 250_240	240	31	11.7	5200	9.7	2800	50000	67	5.8	5400	5.4	3500	52000	61	
	VFR 250_300	300	28	9.3	4800	7.6	2800	50000	63	4.7	5000	4.3	3500	52000	57	
					n ₁ = 900 min ⁻¹					n ₁ = 500 min ⁻¹						
VFR 250	VFR 250_30	30	68	30.0	6500	24	3700	39600	84	16.7	7600	16.1	4200	47600	83	189
	VFR 250_45	45	63	20.0	6800	17.5	3700	48000	82	11.1	7900	11.6	3500	52000	80	
	VFR 250_60	60	58	15.0	7600	15.2	3700	52000	79	8.3	8600	9.9	3500	52000	76	
	VFR 250_90	90	52	10.0	6500	9.3	3700	52000	74	5.6	7400	6.1	3500	52000	71	
	VFR 250_120	120	40	7.5	7500	8.8	3700	52000	67	4.2	9000	6.2	3500	52000	64	
	VFR 250_150	150	35	6.0	7000	7.0	3700	52000	63	3.3	8600	5.1	3500	52000	59	
	VFR 250_180	180	37	5.0	6700	5.7	3700	52000	62	2.8	7600	3.8	3500	52000	59	
	VFR 250_240	240	31	3.8	5800	4.1	3700	52000	56	2.1	6500	2.7	3500	52000	52	
VFR 250_300	300	28	3.0	5300	3.2	3700	52000	52	1.7	6000	2.2	3500	52000	48		

(-) Nehmen Sie bitte Kontakt mit unserem Applikationsdienst und Querkraftsdaten angeben (Drehrichtung, Orientierung, Anordnung)



23 KOMBINATION DER VERHÄLTNISSSE IN DEN GETRIEBEN DER SERIE VF/VF, VF/W, W/VF

	Verhältnisse										i max	
	245	350	420	560	700	840	1120	1680	2100			
VF/VF 30/44												6000
VF 30	7	10	15	20	20	30	40	60	60			60
VF 44	35	35	28	28	35	28	28	28	35			100
VF/VF 30/49	240	315	420	540	720	900	1120	1440	2160	2700		6000
VF 30	10	7	15	15	20	20	40	40	60	60		60
VF 49	24	45	28	36	36	45	28	36	36	45		100
VF/W 30/63	240	315	450	570	720	900	1200	1520	2280	2700		7000
VF 30	10	7	15	15	30	30	40	40	60	60		70
W 63	24	45	30	38	24	30	30	38	38	45		100
VF/W 44/75	250	300	400	525	700	920	1200	1500	2100	2800		10000
VF 44	10	10	10	35	35	46	60	60	70	70		100
W 75	25	30	40	15	20	20	20	25	30	40		100
VF/W 44/86	230	300	400	525	700	920	1380	1840	2116	2760		10000
VF 44	10	10	10	35	35	46	46	46	46	60		100
W 86	23	30	40	15	20	20	30	40	46	46		100
VF/W 49/110	230	300	400	540	720	1080	1350	1656	2070	2800		10000
VF 49	10	10	10	18	36	36	45	36	45	70		100
W 110	23	30	40	30	20	30	30	46	46	40		100
W/VF 63/130	280	400	600	760	960	1200	1520	1800	2560	3200		10000
W 63	7	10	15	19	24	30	38	45	64	80		100
VF 130	40	40	40	40	40	40	40	40	40	40		100
W/VF 86/150	200	225	300	345	460	529	690	920	1380	1840	2944	10000
W 86	10	15	15	15	20	23	23	23	46	46	64	100
VF 150	20	15	20	23	23	23	30	40	30	40	46	100
W/VF 86/185	280	400	600	800	920	1200	1600	1840	2560	3200		10000
W 86	7	10	15	20	23	30	40	46	64	80		100
VF 185	40	40	40	40	40	40	40	40	40	40		100
VF/VF 130/210	280	400	600	800	920	1200	1600	1840	2560	3200		10000
VF 130	7	10	15	20	23	30	40	46	64	80		100
VF 210	40	40	40	40	40	40	40	40	40	40		100
VF/VF 130/250	280	400	600	800	920	1200	1600	1840	2560	3200		10000
VF 130	7	10	15	20	23	30	40	46	64	80		100
VF 250	40	40	40	40	40	40	40	40	40	40		100

Die Untersetzungskombinationen in dieser Tabelle sind die empfehlende Kombinationen von Herstellern.

Die technische Abteilung von Bonfiglioli könnte die Möglichkeit prüfen, weitere Kombination zu realisieren aber diese Untersetzungskombinationen müssen einen Gesamtwert kleiner als die Max. Untersetzung in der Tabelle haben.



24 MOTOR ANBAUMÖGLICHKEITEN

24.1 Motoren nach IEC-Standard

In den Tabellen werden die von den Größen her gesehenen möglichen Passungen angegeben. Die angemessene Getriebewahl muss unter Befolgung der im Paragraph: „Antriebsauswahl“ gegebenen Anleitungen und auf der Grundlage der Auswahltabelle der technischen Daten erfolgen.

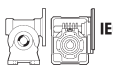
 IEC	VF 27	VF 30	VF 44	VF 49	W 63	W 75	W 86	W 110	VF 130	VF 150	VF 185	VF 210	VF 250
P27 —	7...70	—	—	—	—	—	—	—	—	—	—	—	—
P56 $\frac{B5}{B14}$	—	7...70	—	—	—	—	—	—	—	—	—	—	—
P63 $\frac{B5}{B14}$	—	7...60	7...100	7...100	—	—	—	—	—	—	—	—	—
P71 $\frac{B5}{B14}$	—	—	7...35	7...60	7...100	$\frac{7...100}{—}$	$\frac{7...100}{—}$	—	—	—	—	—	—
P80 $\frac{B5}{B14}$	—	—	—	7...28	7...100	7...100	7...100	7...100	—	—	—	—	—
P90 $\frac{B5}{B14}$	—	—	—	—	7...30	7...100	7...100	7...100	$\frac{46...100}{—}$	—	—	—	—
P100 $\frac{B5}{B14}$	—	—	—	—	—	7...100	7...100	7...100	$\frac{7...80}{—}$	$\frac{23...100}{—}$	$\frac{50...100}{—}$	—	—
P112 $\frac{B5}{B14}$	—	—	—	—	—	7...100	7...100	7...100	$\frac{7...80}{—}$	$\frac{23...100}{—}$	$\frac{50...100}{—}$	—	—
P132 B5	—	—	—	—	—	—	—	7...100	7...40 #	7...46	30...80	7...100	7...100
P160 B5	—	—	—	—	—	—	—	—	—	7...20 #	15...40	7...100	7...100
P180 B5	—	—	—	—	—	—	—	—	—	—	7...20 #	7...100	7...100
P200 B5	—	—	—	—	—	—	—	—	—	—	—	7...100	7...100
P225 B5	—	—	—	—	—	—	—	—	—	—	—	7...100	7...100

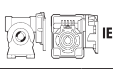
 IEC	VFR 44	VFR 49	WR 63	WR 75	WR 86	WR 110	VFR 130	VFR 150	VFR 185	VFR 210	VFR 250
S44 —	70...500	—	—	—	—	—	—	—	—	—	—
P63 B5	—	30...300	21...300	21...300	21...300	—	—	—	—	—	—
P71 B5	—	—	21...300	21...300	21...300	21...300	—	—	—	—	—
P80 B5	—	—	—	21...300	21...300	21...300	30...300	—	—	—	—
P90 B5	—	—	—	15...150	15...150	21...300	30...300	$\frac{30...300}{\ominus(37.5;50)}$	$\frac{30...300}{\ominus(37.5;50)}$ $\frac{\ominus(75;100)}{\ominus(75;100)}$	—	—
P100 B5	—	—	—	—	—	21...300	30...300 #	$\frac{30...300}{\ominus(37.5;50)}$	$\frac{30...300}{\ominus(37.5;50)}$ $\frac{\ominus(75;100)}{\ominus(75;100)}$	30...300	30...300
P112 B5	—	—	—	—	—	21...300	30...300 #	$\frac{30...300}{\ominus(37.5;50)}$	$\frac{30...300}{\ominus(37.5;50)}$ $\frac{\ominus(75;100)}{\ominus(75;100)}$	30...300	30...300
P132 B5	—	—	—	—	—	—	—	$\frac{25...50 \#}{\ominus(30;45)}$	$\frac{25...100 \#}{\ominus(30;45)}$ $\frac{\ominus(60;90)}{\ominus(60;90)}$	30...300	30...300
P160 B5	—	—	—	—	—	—	—	—	—	30...300 #	30...300 #

■ Untersetzung der Vorstufe i = 1.5

Motorgetriebe-Kombinationen durch [#] gekennzeichnet und werden mit abgeflachten Keilnut entwickelt, die gemeinsam mit den Getriebe geliefert werden.

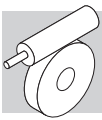

IEC		VF/VF 30/44	VF/VF 30/49	VF/W 30/63	VF/W 44/75	VF/W 44/86	VF/W 49/110	W/VF 63/130	W/VF 86/150	W/VF 86/185	VF/VF 130/210	VF/VF 130/250
P56	B5	—	—	240...2700	—	—	—	—	—	—	—	—
	B14	245...2100	240...2700	240...2700	—	—	—	—	—	—	—	—
P63	B5	—	—	240...2700	—	—	—	—	—	—	—	—
	B14	245...2100	240...2700	240...2700	250...2800	230...2760	230...2800	—	—	—	—	—
P71	B5	—	—	—	250...700	230...700	230...2400	280...3200	200...2944	280...3200	—	—
	B14	—	—	—	—	—	—	—	—	—	—	—
P80	B5	—	—	—	—	—	230...540	280...3200	200...2944	280...3200	—	—
	B14	—	—	—	—	—	—	—	—	—	—	—
P90	B5	—	—	—	—	—	—	280...1200	200...2944	280...3200	280...3200	280...3200
	B14	—	—	—	—	—	—	—	—	—	—	—
P100	B5	—	—	—	—	—	—	—	200...2944	280...3200	280...3200	280...3200
	B14	—	—	—	—	—	—	—	—	—	—	—
P112	B5	—	—	—	—	—	—	—	200...2944	280...3200	280...3200	280...3200
	B14	—	—	—	—	—	—	—	—	—	—	—
P132	B5	—	—	—	—	—	—	—	—	—	280...1600 #	280...1600 #

Motorgetriebe-Kombinationen durch [#] gekennzeichnet und werden mit abgeflachten Keilnut entwickelt, die gemeinsam mit den Getriebe geliefert werden.

24.2 Kompaktmotor

	M1 - ME1 MXN10	M2 - ME2 MX2 - MXN20	ME3 MX3		M1 - ME1 MXN10	M2 - ME2 MX2 - MXN20	ME3 MX3
W 63	7 ... 100	7 ... 100	☐		W/VF 63/130	280 ... 3200	280 ... 3200
W 75	7 ... 100	7 ... 100	7 ... 100		W/VF 86/150	200 ... 2944	200 ... 2944
W 86	7 ... 100	7 ... 100	7 ... 100		W/VF 86/185	280 ... 3200	280 ... 3200
W 110	☐	7 ... 100	7 ... 100				

24.3 Max. installierbare Leistung für IEC Motoradapter P_

		P63			P71			P80				P90				P100			P112		
		BN	BE	BXN	BN	BE	BXN	BN	BE	BX	BXN	BN	BE	BX	BXN	BN	BE	BX	BN	BE	BX
[kW]	2p	0.37	—	—	0.75	—	—	1.5	1.1	—	—	2.2	2.2	—	—	4	3	—	4	4	—
	4p	0.25	0.18	0.18	0.55	0.37	0.37	1.1	0.75	0.75	0.75	1.85	1.5	1.5	1.5	3	3	3	4	4	4
	6p	0.12	—	—	0.37	—	—	0.75	—	—	—	1.1	0.75	—	—	1.85	1.5	—	2.2	2.2	—
		P132			P160			P180			P200		P225								
		BN	BE	BX	BN	BE	BX	BN	BE	BX	BN	IEC	BN	IEC							
[kW]	2p	9.2	9.2	—	18.5	18.5	—	22	—	—	30	45	30	45							
	4p	9.2	9.2	7.5	15	15	15	22	22	22	30	45	30	45							
	6p	5.5	4	—	11	7.5	—	15	—	—	18.5	30	18.5	30							

24.4 Nicht genormte Motoren

Für die Passung an nicht genormte Elektromotoren kann die Schnittstelle des Motors der zu den Serien VF und W gehörenden Getriebe mit der Kombination Antriebswelle/ Hybridflansch konfiguriert werden, die jedoch nicht der Richtlinie IEC entspricht. Die Kombination von Welle/ Flansch wird durch die jeweiligen Durchmesser gegeben und nachstehend aufgeführt.

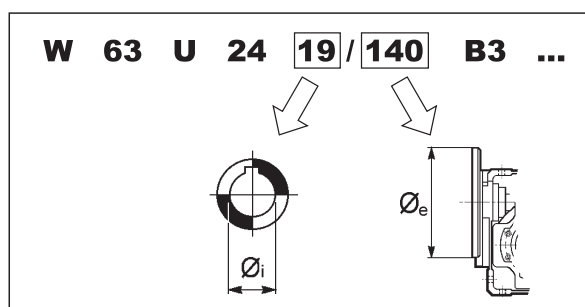

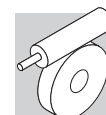

Die verfügbaren Kombinationen von Welle/Flansch und die Übersetzungsverhältnisse, auf die sie jeweils beschränkt sind, werden in den nachstehenden Tabelle angegeben.

		80	90	105	120	140	160	200
VF 30	9		$7 \leq i \leq 70$	⊖		$7 \leq i \leq 70$	⊖	⊖
	11	$7 \leq i \leq 60$		⊖	$7 \leq i \leq 60$		⊖	⊖
VF 44	HS	⊖	$7 \leq i \leq 100$	$7 \leq i \leq 100$	⊖	$7 \leq i \leq 100$	$7 \leq i \leq 100$	⊖
	11	⊖		$7 \leq i \leq 100$	⊖		$7 \leq i \leq 100$	⊖
	14	⊖	$7 \leq i \leq 35$		⊖	$7 \leq i \leq 35$		⊖
VF 49	HS	⊖	$7 \leq i \leq 100$	$7 \leq i \leq 100$	$7 \leq i \leq 100$	$7 \leq i \leq 100$	$7 \leq i \leq 100$	$7 \leq i \leq 100$
	11	⊖		$7 \leq i \leq 100$	$7 \leq i \leq 100$		$7 \leq i \leq 100$	$7 \leq i \leq 100$
	14	⊖	$7 \leq i \leq 60$		$7 \leq i \leq 60$	$7 \leq i \leq 60$		$7 \leq i \leq 60$
	19	⊖	$7 \leq i \leq 28$	$7 \leq i \leq 28$		$7 \leq i \leq 28$	$7 \leq i \leq 28$	
W 63	19	⊖	⊖	⊖	⊖	$7 \leq i \leq 100$	⊖	
W 75	14	⊖	⊖	⊖	⊖	⊖		$7 \leq i \leq 100$
	19	⊖	⊖	⊖		$7 \leq i \leq 100$	$7 \leq i \leq 100$	
	24	⊖	⊖	⊖	$7 \leq i \leq 100$		$7 \leq i \leq 100$	
W 86	14	⊖	⊖	⊖	⊖	⊖		$7 \leq i \leq 100$
	19	⊖	⊖	⊖		$7 \leq i \leq 100$	$7 \leq i \leq 100$	
	24	⊖	⊖	⊖	$7 \leq i \leq 100$		$7 \leq i \leq 100$	
W 110	19	⊖	⊖	⊖		$7 \leq i \leq 100$	⊖	⊖
	24	⊖	⊖	⊖	$7 \leq i \leq 100$		⊖	⊖

Standard-Passung

Einige Hybridkombinationen von Welle/Flansch sind auch bei den Getrieben VF mit einem Achsenabstand von 130 und mehr realisierbar.

In diesem Fall bitten wir Sie jedoch, sich hinsichtlich der Verfügbarkeit mit dem Technischen Service der Bonfiglioli in Verbindung zu setzen.

Die aus den vorstehenden Tabelle resultierenden Konfigurationen sind, ausschließlich in Bezug auf die geometrische Kompatibilität, als Möglichkeiten zu verstehen.

Die mechanische Kompatibilität der Einheit aus Motor-Getriebe muss anhand der üblichen Auswahlta-bellen im Hinblick auf Leistung/ Drehzahl geprüft werden.

Insbesondere sind solche Motorpassungen zu vermeiden, die Sicherheitsfaktoren von $S < 0,9$ erzeugen.

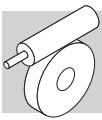

25 TRÄGHEITSMOMENT

Die In den folgenden Tabellen angegebenen Trägheitsmomente J_r [Kgm²] beziehen sich auf die Getriebeantriebsachse. Um das Lesen der Tabellen zu erleichtern, werden folgende Symbole verwendet:

	<p>Die Werte beziehen sich dem Kompaktgetriebe, ohne Motor. Um das Gesamtträgheitsmoment des Getriebemotors zu ermitteln, muss nur das Trägheitsmoment des Getriebes mit dem Trägheitsmoment des entsprechenden Motors addiert werden (Wert Elektromotorenauswahltabellen entnehmen).</p>		<p>Nur Getriebe vorbereitet für IEC-Motor (IEC-Größe...).</p>
			<p>Dieses Symbol bezieht sich auf Getriebewerte.</p>

VF 27



		i	J ($\cdot 10^{-4}$) [kgm ²]				
			P27				HS
VF 27	VF 27_7	7	0.02	—	—	—	0.02
	VF 27_10	10	0.01	—	—	—	0.01
	VF 27_15	15	0.01	—	—	—	0.01
	VF 27_20	20	0.01	—	—	—	0.01
	VF 27_30	30	0.01	—	—	—	0.01
	VF 27_40	40	0.01	—	—	—	0.01
	VF 27_60	60	0.01	—	—	—	0.01
	VF 27_70	70	0.01	—	—	—	0.01

VF 30

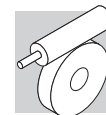
		i	J ($\cdot 10^{-4}$) [kgm ²]				
			P56	P63			HS
VF 30	VF 30_7	7	0.08	0.07	—	—	0.04
	VF 30_10	10	0.07	0.06	—	—	0.03
	VF 30_15	15	0.07	0.06	—	—	0.03
	VF 30_20	20	0.06	0.06	—	—	0.03
	VF 30_30	30	0.06	0.06	—	—	0.03
	VF 30_40	40	0.06	0.06	—	—	0.03
	VF 30_60	60	0.06	0.05	—	—	0.02
	VF 30_70	70	0.06	—	—	—	0.02



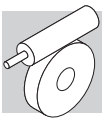

VF 44 - VFR 44

		i	J ($\cdot 10^{-4}$) [kgm ²]					
			 S44	P63	P71	 HS		
VF 44	VF 44_7	7	—	0.29	0.27	—	—	0.18
	VF 44_10	10	—	0.24	0.22	—	—	0.14
	VF 44_14	14	—	0.23	0.21	—	—	0.12
	VF 44_20	20	—	0.19	0.18	—	—	0.09
	VF 44_28	28	—	0.21	0.19	—	—	0.11
	VF 44_35	35	—	0.19	0.18	—	—	0.09
	VF 44_46	46	—	0.18	—	—	—	0.08
	VF 44_60	60	—	0.17	—	—	—	0.07
	VF 44_70	70	—	0.17	—	—	—	0.07
	VF 44_100	100	—	0.17	—	—	—	0.07
VFR 44	VFR 44_70	70	0.21	—	—	—	—	—
	VFR 44_100	100	0.20	—	—	—	—	—
	VFR 44_140	140	0.20	—	—	—	—	—
	VFR 44_175	175	0.20	—	—	—	—	—
	VFR 44_230	230	0.20	—	—	—	—	—
	VFR 44_300	300	0.20	—	—	—	—	—
	VFR 44_350	350	0.20	—	—	—	—	—
	VFR 44_500	500	0.20	—	—	—	—	—

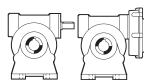

VF 49 - VFR 49

		i	J ($\cdot 10^{-4}$) [kgm ²]					
			P63	P71	  P80	 HS		
VF 49	VF 49_7	7	0.69	0.67	0.61	—	—	0.42
	VF 49_10	10	0.61	0.60	0.53	—	—	0.34
	VF 49_14	14	0.58	0.57	0.5	—	—	0.31
	VF 49_18	18	0.54	0.53	0.46	—	—	0.27
	VF 49_24	24	0.52	0.5	0.44	—	—	0.24
	VF 49_28	28	0.56	0.54	0.48	—	—	0.28
	VF 49_36	36	0.53	0.51	—	—	—	0.25
	VF 49_45	45	0.51	0.49	—	—	—	0.24
	VF 49_60	60	0.50	0.48	—	—	—	0.23
	VF 49_70	70	0.50	—	—	—	—	0.22
	VF 49_80	80	0.49	—	—	—	—	0.22
VF 49_100	100	0.49	—	—	—	—	0.22	
VFR 49	VFR 49_30	30	0.74	—	—	—	—	0.94
	VFR 49_42	42	0.73	—	—	—	—	0.93
	VFR 49_54	54	0.73	—	—	—	—	0.93
	VFR 49_72	72	0.73	—	—	—	—	0.93
	VFR 49_84	84	0.73	—	—	—	—	0.93
	VFR 49_108	108	0.73	—	—	—	—	0.93
	VFR 49_135	135	0.73	—	—	—	—	0.93
	VFR 49_180	180	0.73	—	—	—	—	0.93
	VFR 49_210	210	0.72	—	—	—	—	0.92
	VFR 49_240	240	0.72	—	—	—	—	0.92
	VFR 49_300	300	0.72	—	—	—	—	0.92

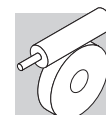

W 63 - WR 63

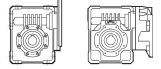
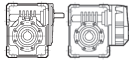
		i	J ($\cdot 10^{-4}$) [kgm ²]									
												
			S1	S2	S3	P63	P71	P80	P90			HS
W 63	W 63_7	7	3.4	3.6	—	—	3.5	3.5	3.5	—	—	3.6
	W 63_10	10	3.1	3.3	—	—	3.2	3.3	3.2	—	—	3.3
	W 63_12	12	3.1	3.3	—	—	3.1	3.2	3.1	—	—	3.3
	W 63_15	15	3.0	3.2	—	—	3.0	3.1	3.0	—	—	3.2
	W 63_19	19	2.9	3.1	—	—	2.9	3.0	2.9	—	—	3.1
	W 63_24	24	2.8	3.1	—	—	2.9	3.0	2.9	—	—	3.0
	W 63_30	30	2.9	3.1	—	—	2.9	3.0	2.9	—	—	3.1
	W 63_38	38	2.8	3.1	—	—	2.9	3.0	2.9	—	—	3.0
	W 63_45	45	2.8	3.0	—	—	2.9	2.9	2.9	—	—	3.0
	W 63_64	64	2.8	3.0	—	—	2.8	2.9	2.8	—	—	3.0
	W 63_80	80	2.8	3.0	—	—	2.8	2.9	2.8	—	—	3.0
W 63_100	100	2.8	3.0	—	—	2.8	2.9	2.8	—	—	2.9	
WR 63	WR 63_21	21	—	—	—	0.84	0.83	—	—	—	—	0.81
	WR 63_30	30	—	—	—	0.81	0.80	—	—	—	—	0.78
	WR 63_36	36	—	—	—	0.81	0.80	—	—	—	—	0.77
	WR 63_45	45	—	—	—	0.80	0.79	—	—	—	—	0.76
	WR 63_57	57	—	—	—	0.79	0.78	—	—	—	—	0.75
	WR 63_72	72	—	—	—	0.78	0.77	—	—	—	—	0.74
	WR 63_90	90	—	—	—	0.79	0.78	—	—	—	—	0.75
	WR 63_114	114	—	—	—	0.78	0.77	—	—	—	—	0.74
	WR 63_135	135	—	—	—	0.78	0.77	—	—	—	—	0.74
	WR 63_192	192	—	—	—	0.77	0.76	—	—	—	—	0.74
	WR 63_240	240	—	—	—	0.77	0.76	—	—	—	—	0.74
WR 63_300	300	—	—	—	0.77	0.76	—	—	—	—	0.73	

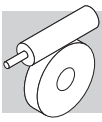

W 75 - WR 75

		i	J ($\cdot 10^{-4}$) [kgm ²]									
			 S1 S2 S3			 P63 P71 P80 P90 P100 P112						 HS
W 75	W 75_7	7	6.9	6.6	6.6	—	6.9	7.0	6.9	6.9	6.9	7.3
	W 75_10	10	6.4	6.1	6.1	—	6.4	6.4	6.3	5.7	5.7	6.8
	W 75_15	15	6.1	5.8	5.8	—	6.1	6.1	6.0	5.3	5.3	6.5
	W 75_20	20	5.9	5.6	5.6	—	5.9	5.9	5.9	5.2	5.2	6.3
	W 75_25	25	5.9	5.6	5.6	—	6.0	6.0	5.9	5.2	5.2	6.3
	W 75_30	30	5.9	5.6	5.6	—	5.9	5.9	5.9	5.2	5.2	6.3
	W 75_40	40	5.9	5.6	5.6	—	5.9	5.9	5.8	5.2	5.2	6.3
	W 75_50	50	5.9	5.6	5.6	—	5.9	5.9	5.8	5.1	5.1	6.2
	W 75_60	60	5.8	5.5	5.5	—	5.8	5.9	5.8	5.1	5.1	6.2
	W 75_80	80	5.8	5.5	5.5	—	5.8	5.8	5.8	5.1	5.1	6.2
W 75_100	100	5.8	5.5	5.5	—	5.8	5.8	5.7	5.0	5.0	6.2	





WR 75	WR 75_21	21	—	—	—	1.2	1.2	2.1	—	—	—	1.9
	WR 75_30	30	—	—	—	1.1	1.1	2.1	—	—	—	1.1
	WR 75_45	45	—	—	—	1.1	1.1	2.0	—	—	—	1.1
	WR 75_60	60	—	—	—	1.1	1.1	2.0	—	—	—	1.0
	WR 75_75	75	—	—	—	1.1	1.1	2.0	—	—	—	1.0
	WR 75_90	90	—	—	—	1.1	1.1	2.0	—	—	—	1.0
	WR 75_120	120	—	—	—	1.1	1.1	2.0	—	—	—	1.0
	WR 75_150	150	—	—	—	1.1	1.1	2.0	—	—	—	1.0
	WR 75_180	180	—	—	—	1.1	1.1	2.0	—	—	—	1.0
	WR 75_240	240	—	—	—	1.1	1.1	2.0	—	—	—	1.0
WR 75_300	300	—	—	—	1.1	1.1	2.0	—	—	—	1.0	

		J ($\cdot 10^{-4}$) [kgm ²]	
		i	 P90

WR 75_P90 B5	WR 75_15	15	6.0
	WR 75_22.5	22.5	5.9
	WR 75_30	30	5.8
	WR 75_37.5	37.5	5.8
	WR 75_45	45	5.8
	WR 75_60	60	5.8
	WR 75_75	75	5.8
	WR 75_90	90	5.7
	WR 75_120	120	5.7
WR 75_150	150	5.7	



W 86 - WR 86

		i	J ($\cdot 10^{-4}$) [kgm ²]									
			 S1 S2 S3			  P63 P71 P80 P90 P100					  HS	
W 86	W 86_7	7	9.7	9.4	9.4	—	9.7	9.7	9.6	9.6	—	10.1
	W 86_10	10	8.4	8.1	8.1	—	8.4	8.4	8.3	7.7	—	8.9
	W 86_15	15	7.7	7.4	7.4	—	7.7	7.7	7.7	7.0	—	8.2
	W 86_20	20	6.9	6.6	6.6	—	6.9	7.0	6.9	6.2	—	7.4
	W 86_23	23	6.8	6.5	6.5	—	6.8	6.9	6.8	6.1	—	7.3
	W 86_30	30	7.3	7.0	7.0	—	7.3	7.3	7.3	6.6	—	7.8
	W 86_40	40	6.7	6.4	6.4	—	6.7	6.7	6.6	6.0	—	7.2
	W 86_46	46	6.7	6.4	6.4	—	6.7	6.7	6.6	5.9	—	7.1
	W 86_56	56	6.6	6.3	6.3	—	6.6	6.7	6.6	5.9	—	7.1
	W 86_64	64	6.6	6.3	6.3	—	6.6	6.6	6.5	5.9	—	7.1
	W 86_80	80	6.6	6.3	6.3	—	6.6	6.6	6.5	5.9	—	7.1
	W 86_100	100	6.4	6.1	6.1	—	6.4	6.5	6.4	5.7	—	6.9

WR 86	WR 86_21	21	—	—	—	1.5	1.5	2.4	—	—	—	2.2
	WR 86_30	30	—	—	—	1.4	1.3	2.3	—	—	—	1.3
	WR 86_45	45	—	—	—	1.3	1.3	2.2	—	—	—	1.2
	WR 86_60	60	—	—	—	1.2	1.2	2.1	—	—	—	1.2
	WR 86_69	69	—	—	—	1.2	1.2	2.1	—	—	—	1.1
	WR 86_90	90	—	—	—	1.2	1.2	2.2	—	—	—	1.2
	WR 86_120	120	—	—	—	1.2	1.2	2.1	—	—	—	1.1
	WR 86_138	138	—	—	—	1.2	1.2	2.1	—	—	—	1.1
	WR 86_168	168	—	—	—	1.2	1.2	2.1	—	—	—	1.1
	WR 86_192	192	—	—	—	1.2	1.1	2.1	—	—	—	1.1
	WR 86_240	240	—	—	—	1.2	1.1	2.1	—	—	—	1.1
	WR 86_300	300	—	—	—	1.1	1.1	2.1	—	—	—	1.1

		J ($\cdot 10^{-4}$) [kgm ²]	
		i	 P90

WR 86_P90 B5	WR 86_15	15	6.9
	WR 86_22.5	22.5	6.6
	WR 86_30	30	6.3
	WR 86_34.5	34.5	6.2
	WR 86_45	45	6.4
	WR 86_60	60	6.2
	WR 86_69	69	6.1
	WR 86_84	84	6.1
	WR 86_96	96	6.0
	WR 86_120	120	6.0
	WR 86_150	150	5.9

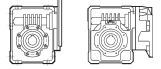
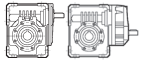

W 110 - WR 110

		i	J ($\cdot 10^{-4}$) [kgm ²]									
												
			S1	S2	S3	P63	P71	P80	P90	P100	P132	HS
W 110	W 110_7	7	—	22	22	—	—	23	23	23	28	23
	W 110_10	10	—	19	19	—	—	19	19	24	24	20
	W 110_15	15	—	17	17	—	—	17	17	22	22	17
	W 110_20	20	—	14	14	—	—	14	14	19	19	15
	W 110_23	23	—	14	14	—	—	14	14	19	19	15
	W 110_30	30	—	15	15	—	—	16	16	20	20	16
	W 110_40	40	—	13	13	—	—	14	14	19	19	14
	W 110_46	46	—	13	13	—	—	13	13	18	18	14
	W 110_56	56	—	13	13	—	—	13	13	18	18	14
	W 110_64	64	—	13	13	—	—	13	13	18	18	14
	W 110_80	80	—	13	13	—	—	13	13	18	18	14
W 110_100	100	—	13	13	—	—	13	13	18	18	14	
WR 110	WR 110_21	21	—	—	—	—	3.0	9.0	8.8	8.9	—	9.2
	WR 110_30	30	—	—	—	—	2.5	8.6	8.4	8.4	—	8.8
	WR 110_45	45	—	—	—	—	2.3	8.3	8.2	8.2	—	8.5
	WR 110_60	60	—	—	—	—	2.0	8.1	7.9	7.9	—	8.3
	WR 110_69	69	—	—	—	—	2.0	8.0	7.9	7.9	—	8.2
	WR 110_90	90	—	—	—	—	2.2	8.2	8.1	8.1	—	8.4
	WR 110_120	120	—	—	—	—	1.9	8.0	7.8	7.9	—	8.2
	WR 110_138	138	—	—	—	—	1.9	8.0	7.8	7.8	—	8.2
	WR 110_168	168	—	—	—	—	1.9	8.0	7.8	7.8	—	8.1
	WR 110_192	192	—	—	—	—	1.9	7.9	7.8	7.8	—	8.1
	WR 110_240	240	—	—	—	—	1.9	7.9	7.8	7.8	—	8.1
WR 110_300	300	—	—	—	—	1.9	7.9	7.8	7.8	—	8.1	





VF 130 - VFR 130

		i	J ($\cdot 10^{-4}$) [kgm ²]					HS
			P80	P90	 P100	P112	P132	
VF 130	VF 130_7	7	—	—	36	36	35	31
	VF 130_10	10	—	—	27	27	25	22
	VF 130_15	15	—	—	20	20	18	15
	VF 130_20	20	—	—	17	17	15	11
	VF 130_23	23	—	—	16	16	14	11
	VF 130_30	30	—	—	17	17	15	12
	VF 130_40	40	—	—	15	15	14	9.9
	VF 130_46	46	—	14	14	14	—	8.2
	VF 130_56	56	—	13	13	13	—	7.8
	VF 130_64	64	—	13	13	13	—	7.4
	VF 130_80	80	—	13	12	12	—	7.0
	VF 130_100	100	—	13	—	—	—	8.9
VFR 130	VFR 130_30	30	5.3	5.3	5.2	5.2	—	5.7
	VFR 130_45	45	4.5	4.5	4.4	4.4	—	4.9
	VFR 130_60	60	4.2	4.1	4.1	4.1	—	4.6
	VFR 130_69	69	4.1	4.0	4.0	4.0	—	4.5
	VFR 130_90	90	4.2	4.1	4.1	4.1	—	4.6
	VFR 130_120	120	4.0	3.9	4.0	4.0	—	4.4
	VFR 130_138	138	3.8	3.8	3.7	3.7	—	4.2
	VFR 130_168	168	3.8	3.7	3.7	3.7	—	4.1
	VFR 130_192	192	3.7	3.7	3.6	3.6	—	4.1
	VFR 130_240	240	3.7	3.6	3.6	3.6	—	4.1
	VFR 130_300	300	3.9	3.8	3.8	3.8	—	4.3



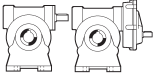

VF 150 - VFR 150

		i	J ($\cdot 10^{-4}$) [kgm ²]				
			P90	 P100	 P112	P132	 HS
VF 150	VF 150_7	7	—	—	—	58	50
	VF 150_10	10	—	—	—	44	35
	VF 150_15	15	—	—	—	29	21
	VF 150_20	20	—	—	—	27	19
	VF 150_23	23	—	28	28	26	17
	VF 150_30	30	—	31	31	29	21
	VF 150_40	40	—	26	26	24	16
	VF 150_46	46	—	24	24	22	13
	VF 150_56	56	25	24	24	—	13
	VF 150_64	64	24	23	23	—	12
	VF 150_80	80	23	22	22	—	11
	VF 150_100	100	23	22	22	—	11
VFR 150	VFR 150_25	25	—	—	—	15	—
	VFR 150_30	30	10	10	10	—	11
	VFR 150_37.5	37.5	—	—	—	13	—
	VFR 150_45	45	8.8	8.8	8.8	—	9.7
	VFR 150_50	50	—	—	—	12	—
	VFR 150_60	60	8.3	8.3	8.3	—	9.2
	VFR 150_69	69	8.4	8.4	8.4	—	9.3
	VFR 150_90	90	8.7	8.7	8.7	—	9.7
	VFR 150_120	120	8.2	8.2	8.2	—	9.2
	VFR 150_138	138	7.9	7.9	7.9	—	8.9
	VFR 150_168	168	7.9	7.9	7.9	—	8.9
	VFR 150_192	192	7.8	7.8	7.8	—	8.8
	VFR 150_240	240	7.7	7.7	7.7	—	8.6
VFR 150_300	300	7.7	7.7	7.7	—	8.6	



VF 185 - VFR 185

		i	J ($\cdot 10^{-4}$) [kgm ²]						HS
			P90	P100	 P112	 P132	P160	P180	
VF 185	VF 185_7	7	—	—	—	—	—	146	128
	VF 185_10	10	—	—	—	—	—	108	91
	VF 185_15	15	—	—	—	—	70	88	50
	VF 185_20	20	—	—	—	—	69	66	48
	VF 185_30	30	—	—	—	58	54	—	34
	VF 185_40	40	—	—	—	63	61	—	41
	VF 185_50	50	—	59	59	58	—	—	35
	VF 185_60	60	—	55	55	53	—	—	31
	VF 185_80	80	—	52	52	51	—	—	28
	VF 185_100	100	—	51	51	—	—	—	27
VFR 185	VFR 185_25	25	—	—	—	24	—	—	—
	VFR 185_30	30	17	17	17	—	—	—	18
	VFR 185_37.5	37.5	—	—	—	17	—	—	—
	VFR 185_45	45	12	12	12	—	—	—	13
	VFR 185_50	50	—	—	—	17	—	—	—
	VFR 185_60	60	12	12	12	—	—	—	13
	VFR 185_75	75	—	—	—	15	—	—	—
	VFR 185_90	90	10	10	10	—	—	—	11
	VFR 185_100	100	—	—	—	16	—	—	—
	VFR 185_120	120	11	11	11	—	—	—	12
	VFR 185_150	150	10	10	10	—	—	—	11
	VFR 185_180	180	9.9	9.9	9.9	—	—	—	11
	VFR 185_240	240	9.6	9.6	9.6	—	—	—	11
VFR 185_300	300	9.5	9.4	9.4	—	—	—	10	



VF 210 - VFR 210

		i	J ($\cdot 10^{-4}$) [kgm ²]							HS
			P100	P112	P132	P160	P180	P200	P225	
VF 210	VF 210_7	7	—	—	286	286	286	286	286	286
	VF 210_10	10	—	—	177	177	177	177	177	177
	VF 210_15	15	—	—	120	120	120	120	120	120
	VF 210_20	20	—	—	116	116	116	116	116	116
	VF 210_30	30	—	—	81	81	81	81	81	81
	VF 210_40	40	—	—	98	98	98	98	98	98
	VF 210_50	50	—	—	84	84	84	84	84	84
	VF 210_60	60	—	—	75	75	75	75	75	75
	VF 210_80	80	—	—	68	68	68	68	68	68
	VF 210_100	100	—	—	63	63	63	63	63	63
VFR 210	VFR 210_30	30	48	48	47	47	—	—	—	51
	VFR 210_45	45	41	41	41	41	—	—	—	45
	VFR 210_60	60	41	41	41	40	—	—	—	45
	VFR 210_90	90	37	37	37	36	—	—	—	41
	VFR 210_120	120	39	39	39	38	—	—	—	43
	VFR 210_150	150	37	37	37	37	—	—	—	41
	VFR 210_180	180	36	36	36	36	—	—	—	40
	VFR 210_240	240	36	36	36	35	—	—	—	39
	VFR 210_300	300	35	35	35	34	—	—	—	39



VF 250 - VFR 250

		i	J ($\cdot 10^{-4}$) [kgm ²]							
			P100	P112	P132	P160	P180	P200	P225	HS
VF 250	VF 250_7	7	—	—	620	620	620	620	620	620
	VF 250_10	10	—	—	387	387	387	387	387	387
	VF 250_15	15	—	—	266	266	266	266	266	266
	VF 250_20	20	—	—	242	242	242	242	242	242
	VF 250_30	30	—	—	184	184	184	184	184	184
	VF 250_40	40	—	—	241	241	241	241	241	241
	VF 250_50	50	—	—	240	240	240	240	240	240
	VF 250_60	60	—	—	158	158	158	158	158	158
	VF 250_80	80	—	—	160	160	160	160	160	160
	VF 250_100	100	—	—	149	149	149	149	149	149
VFR 250	VFR 250_30	30	71	71	71	70	—	—	—	75
	VFR 250_45	45	58	58	57	57	—	—	—	61
	VFR 250_60	60	55	55	55	54	—	—	—	58
	VFR 250_90	90	48	48	48	48	—	—	—	52
	VFR 250_120	120	55	55	54	54	—	—	—	58
	VFR 250_150	150	55	55	54	54	—	—	—	58
	VFR 250_180	180	46	46	45	45	—	—	—	49
	VFR 250_240	240	46	46	45	45	—	—	—	49
	VFR 250_300	300	45	45	44	44	—	—	—	48

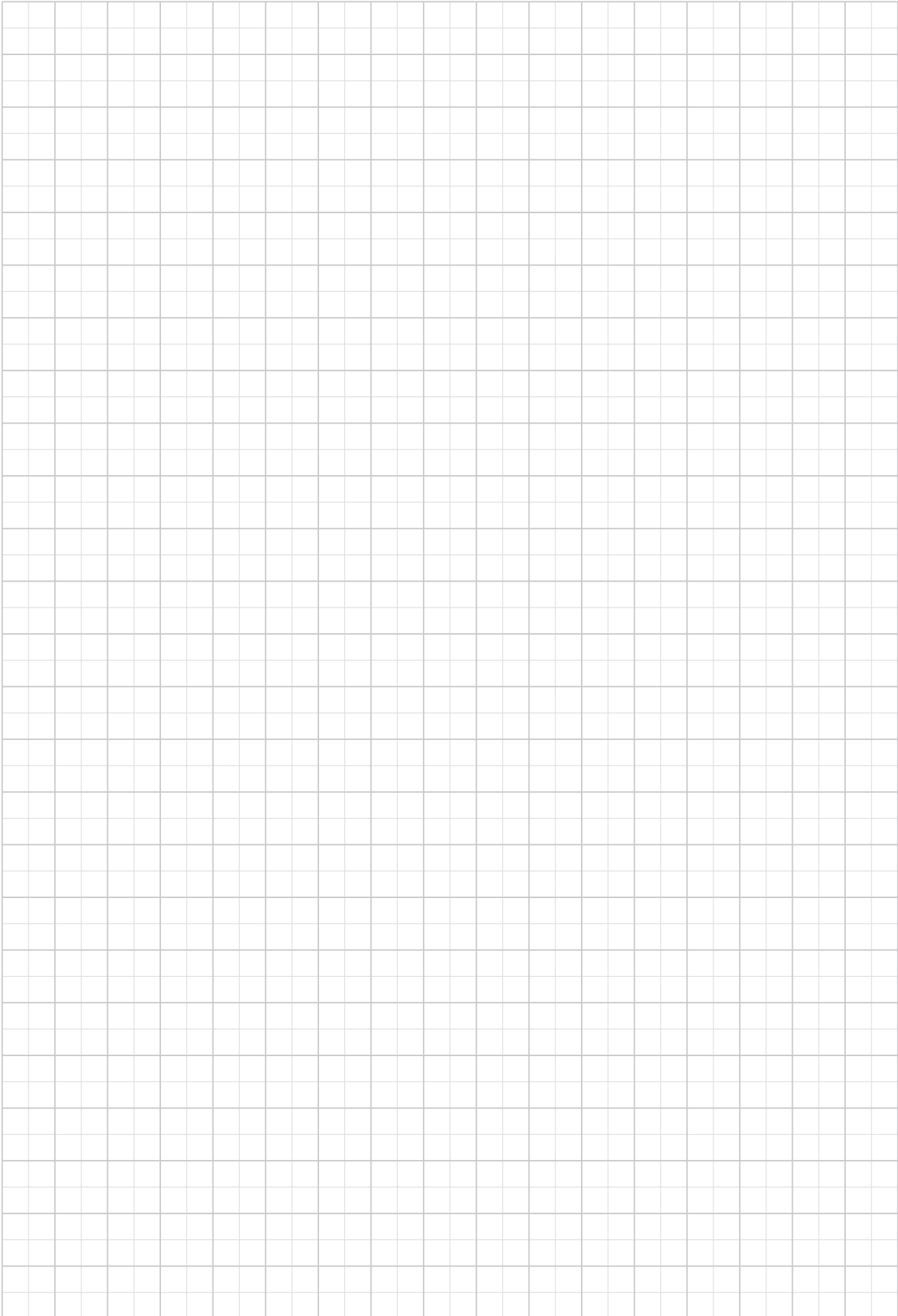
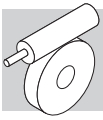

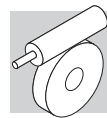

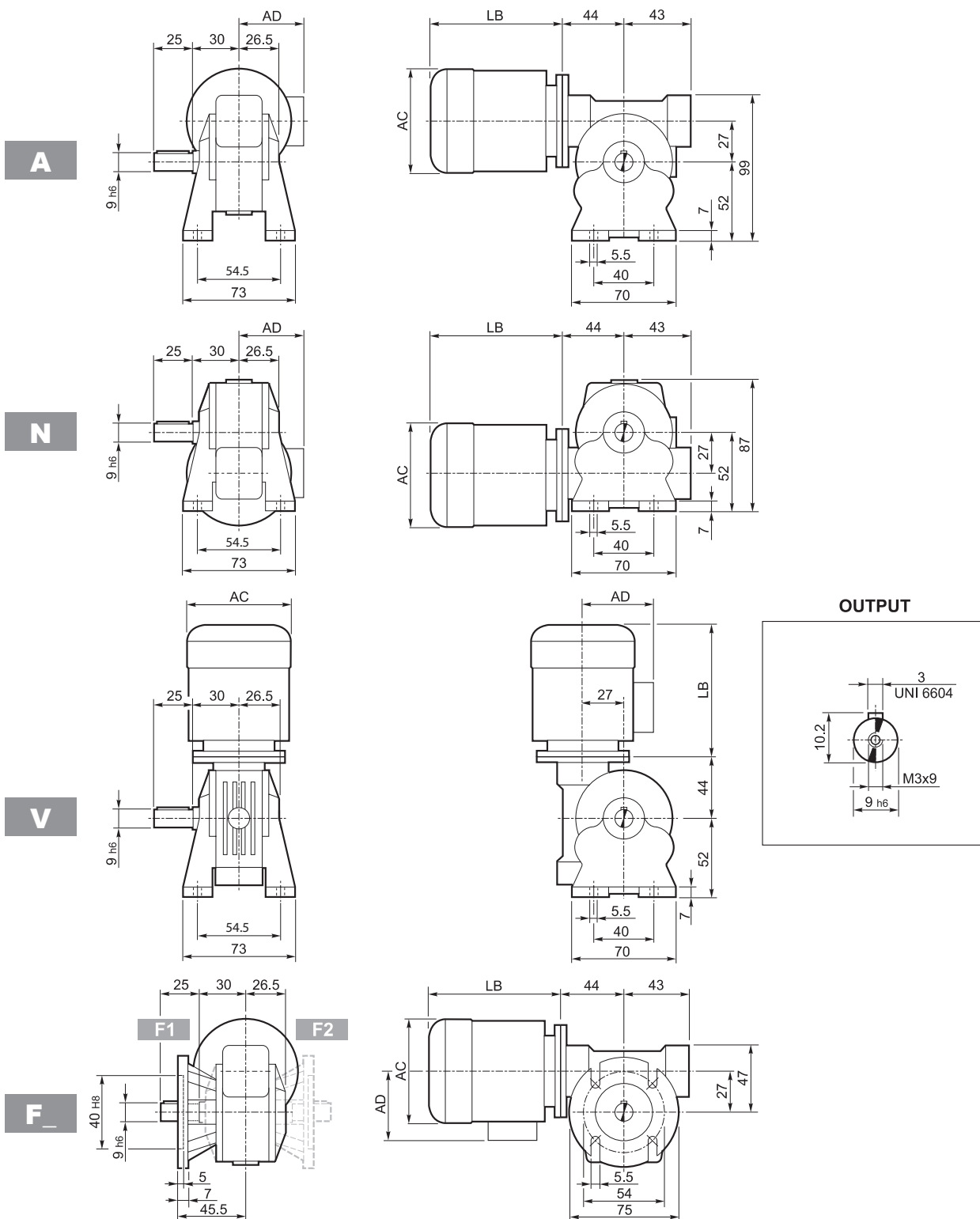

26 ABMESSUNGEN FÜR GETRIEBEMOTOREN UND GETRIEBEN VORBEREITET FÜR IEC-MOTOR

VF 27...BN27



	P _n kW	n min ⁻¹	M _n Nm	η %	COSφ	I _n A (400V)	I _s I _n	M _s M _n	M _a M _n	J _m (·10 ⁻⁴) kgm ²	 Kg	LB	AC	AD
BN 27A 4	0.04	1405	0.27	38.4	0.6	0.25	2.9	3.6	3.1	1.49	3.3	168	112	92
BN 27B 4	0.06	1340	0.43	46.8	0.65	0.28	2.6	2.3	2.0	1.49	3.3	168	112	92
BN 27C 4	0.09	1380	0.63	46	0.65	0.43	2.8	2.3	1.9	1.49	3.3	168	112	92

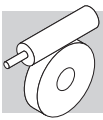

VF 30...P (IEC)

A

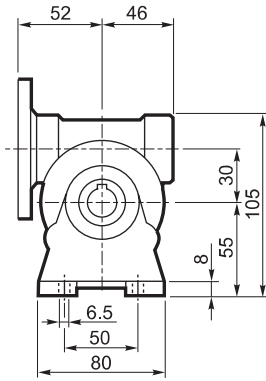
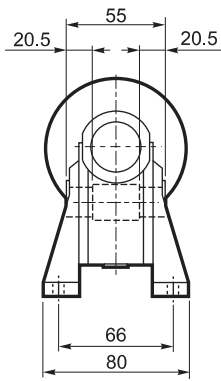

N

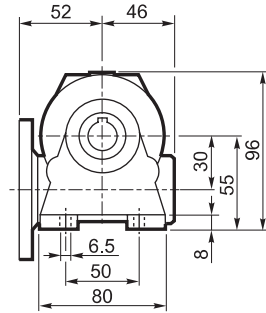
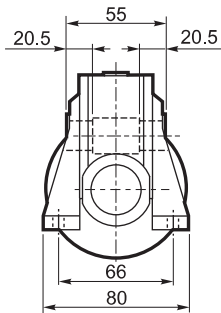

V

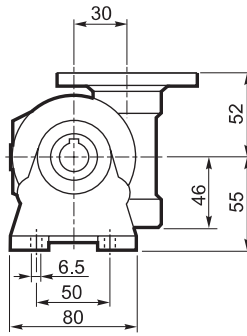
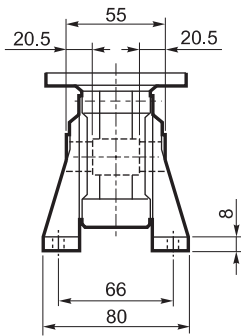

P

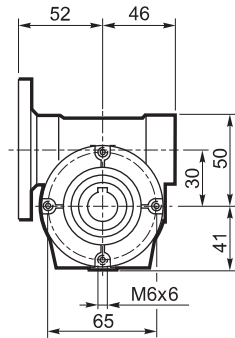
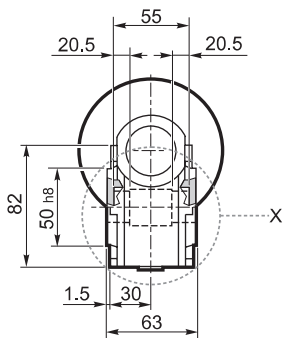

INPUT

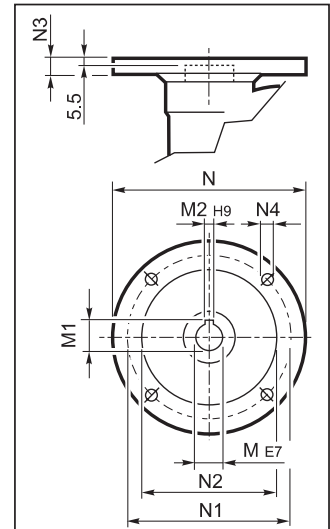

P56 B14

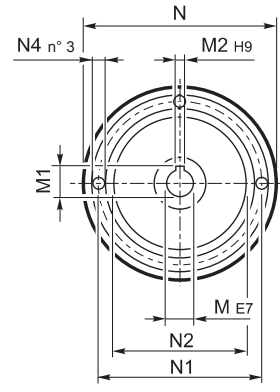

OUTPUT

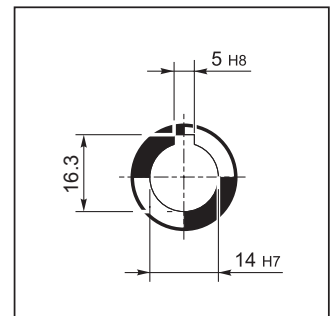

X

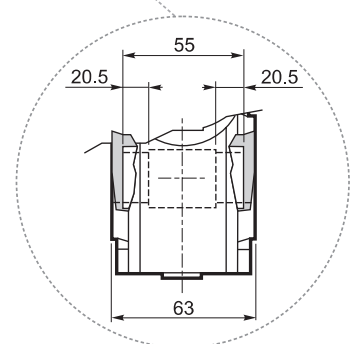

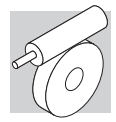

VF 30...P (IEC)

F

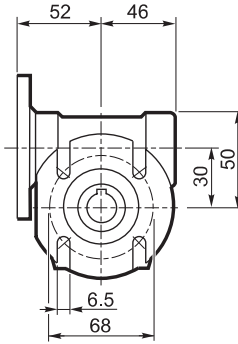
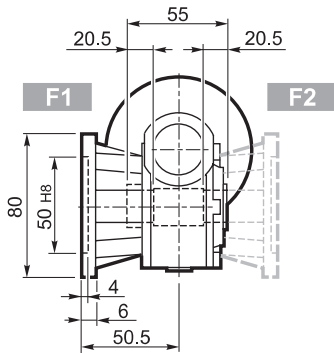

U

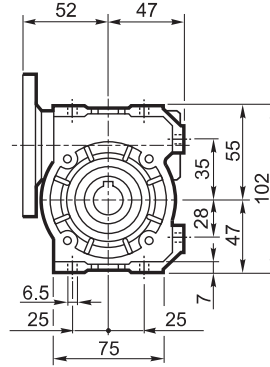
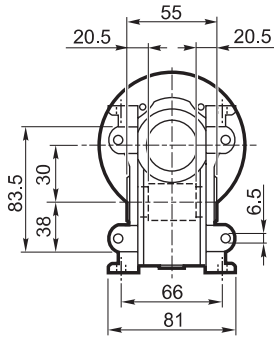

INPUT

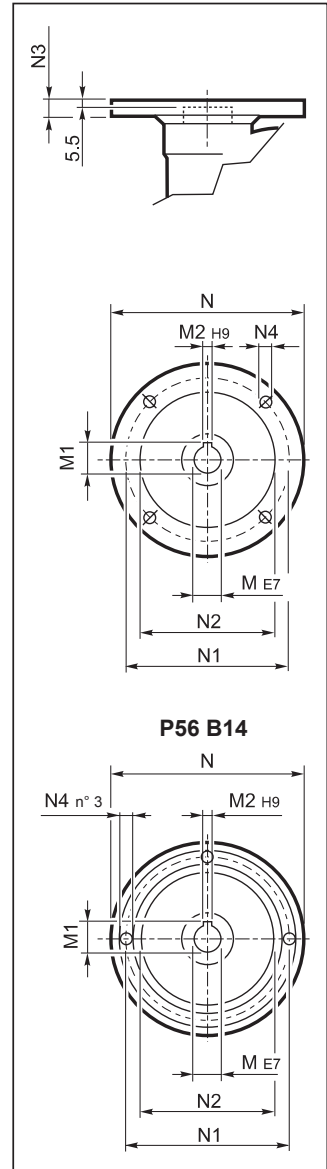

OUTPUT

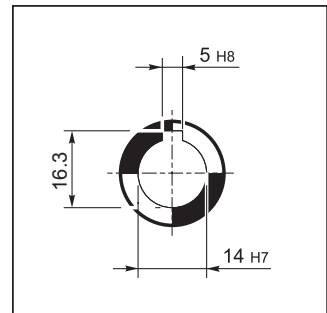

		M	M1	M2	N	N1	N2	N3	N4	
VF 30	P56 B5	9	10.4	3	120	100	80	7	7	1.1
VF 30	P56 B14	9	10.4	3	80	65	50	7	5.5	
VF 30	P63 B5	11	12.8	4	140	115	95	8	9.5	
VF 30	P63 B14	11	12.8	4	90	75	60	6	5.5	

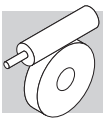

VF 44...P (IEC)

A

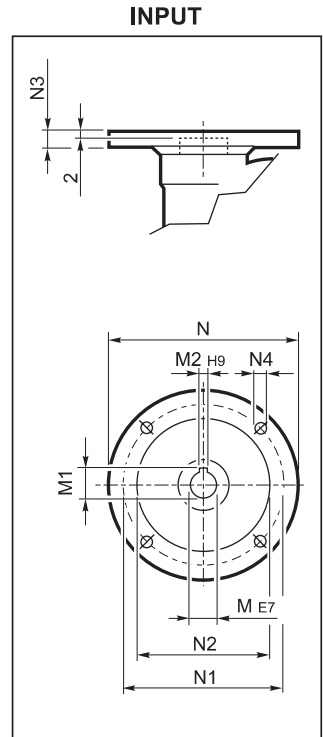
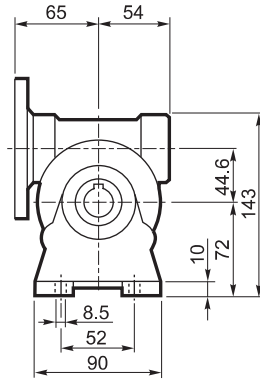
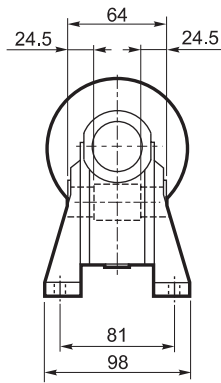

N

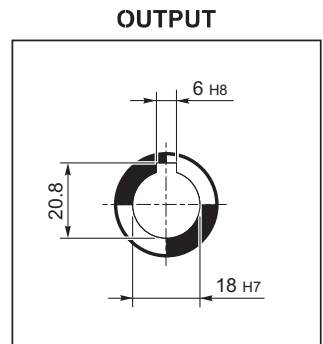
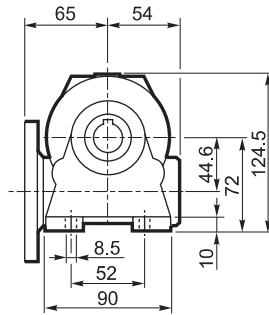
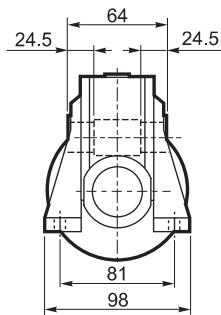

V

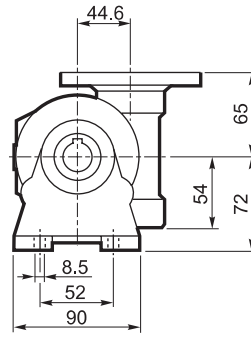
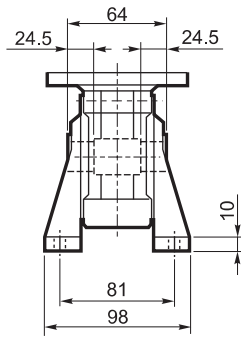

P

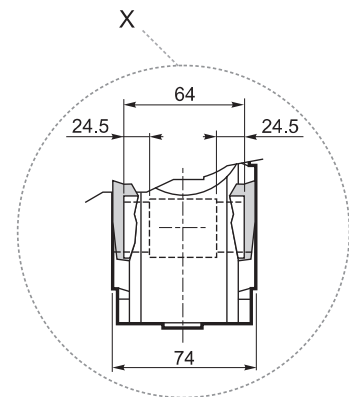
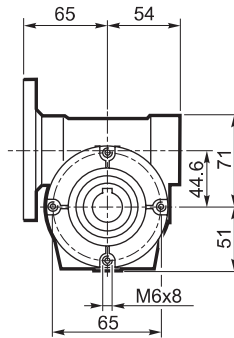
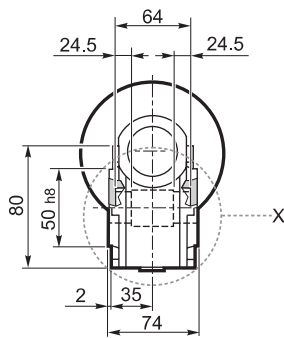

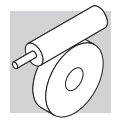

VF 44...P (IEC)

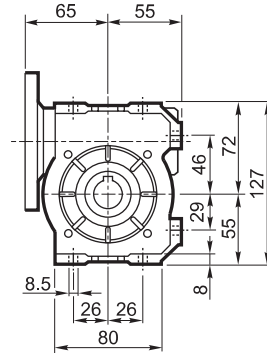
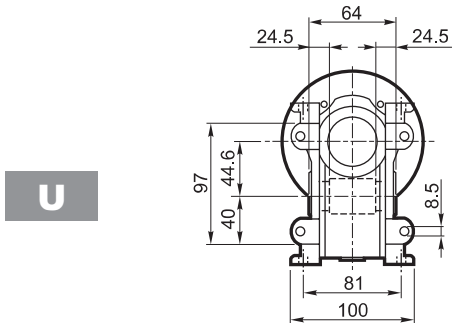
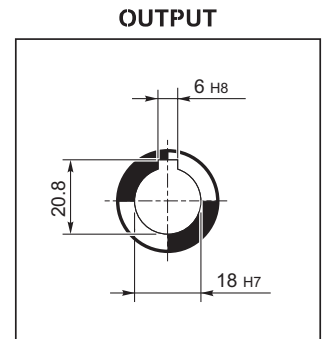
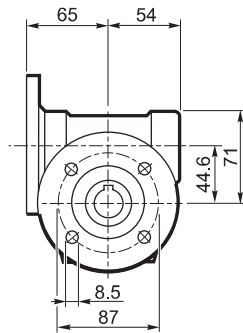
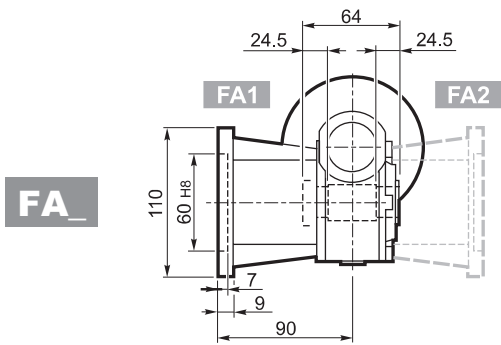
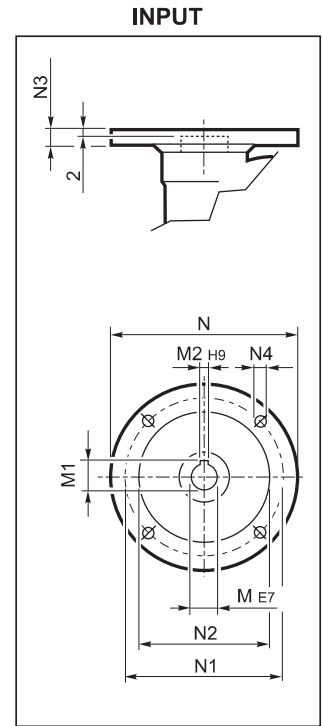
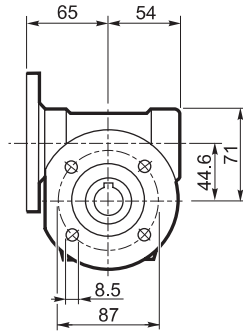
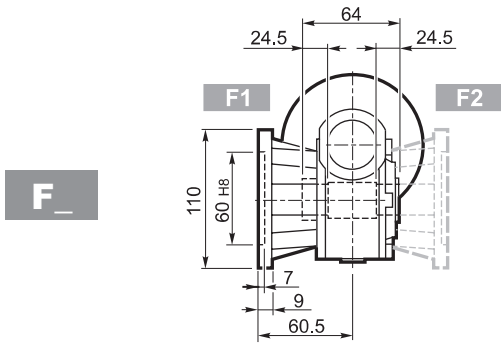

		M	M1	M2	N	N1	N2	N3	N4	
VF 44	P63 B5	11	12.8	4	140	115	95	10	9.5	2.0
VF 44	P71 B5	14	16.3	5	160	130	110	10	9.5	
VF 44	P63 B14	11	12.8	4	90	75	60	8	5.5	
VF 44	P71 B14	14	16.3	5	105	85	70	10	7	

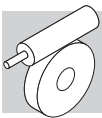

VFR 44...BN 44

A

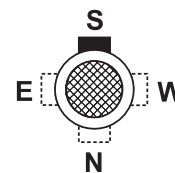
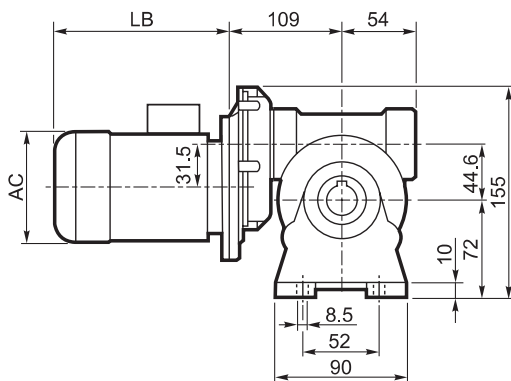
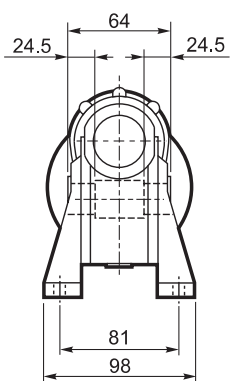

OUTPUT

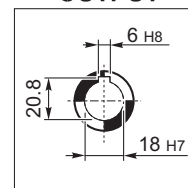

N

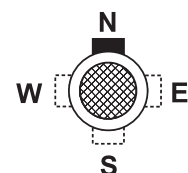
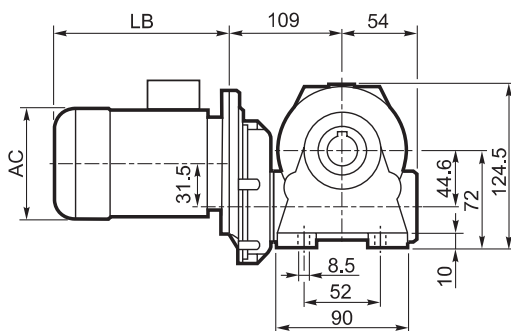
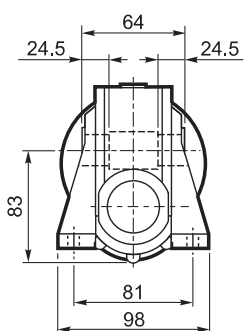

V

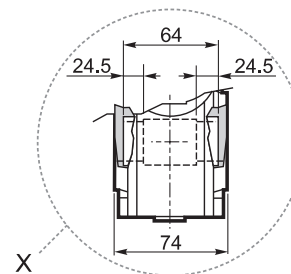
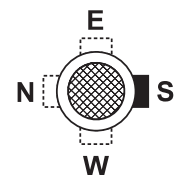
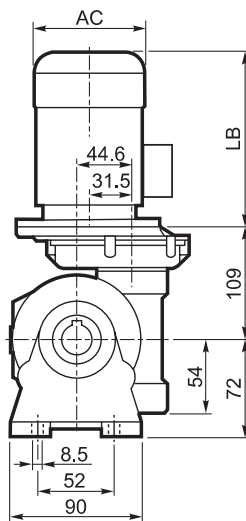
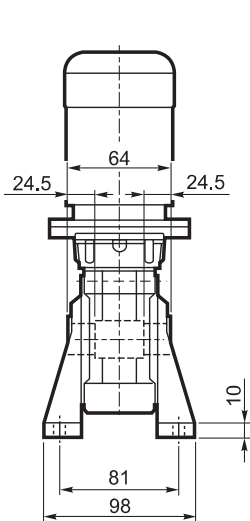

P

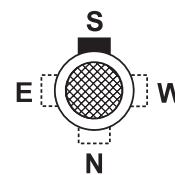
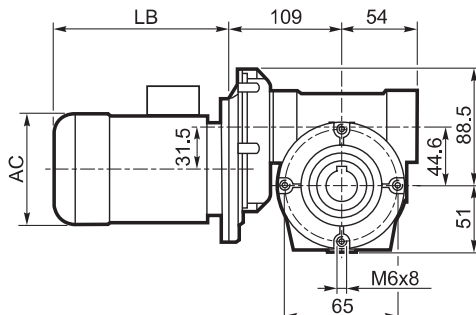
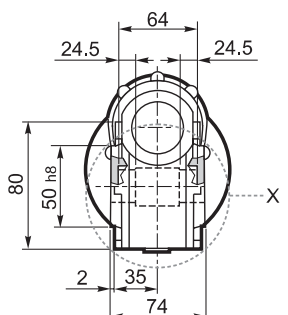



VFR 44...BN 44

F_

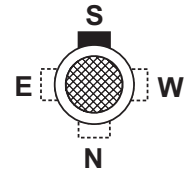
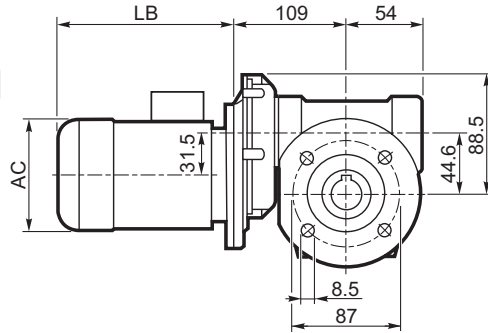
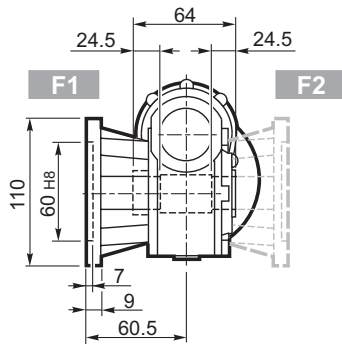

OUTPUT

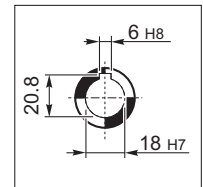

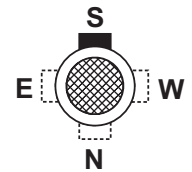
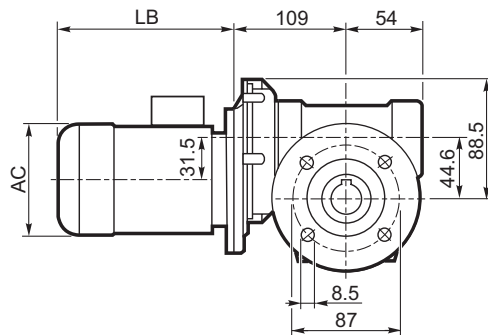
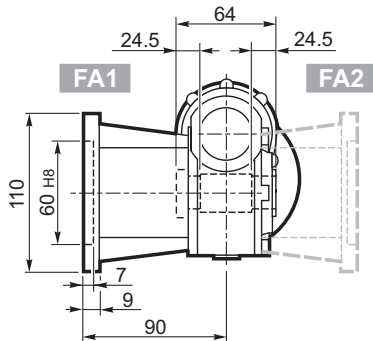

FA_

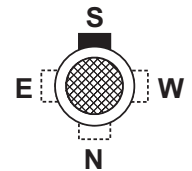
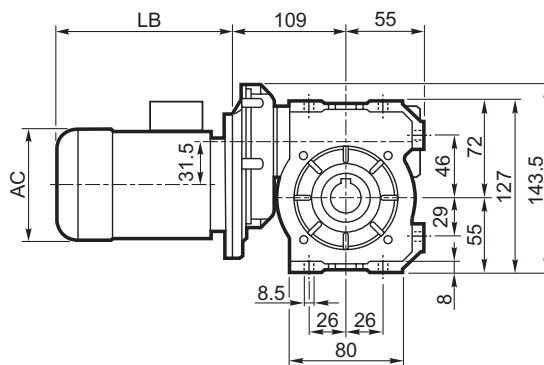
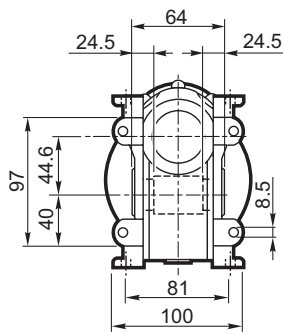

U



	P_n kW	n min ⁻¹	M_n Nm	η %	$\text{COS}\phi$	I_n A (400V)	$\frac{I_s}{I_n}$	$\frac{M_s}{M_n}$	$\frac{M_a}{M_n}$	J_m ($\cdot 10^{-4}$) kgm ²		LB	AC	AD
BN 44B4	0.06	1380	0.42	40	0.58	0.38	2.4	2.3	1.9	1.22	4.7	168	112	94
BN 44C4	0.09	1380	0.63	46	0.65	0.43	2.8	2.3	2	1.49	4.6	168	112	94



VF/VF 30/44...P (IEC)

A

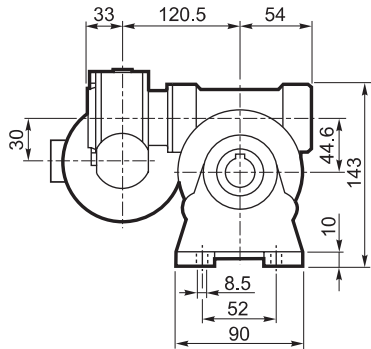

N

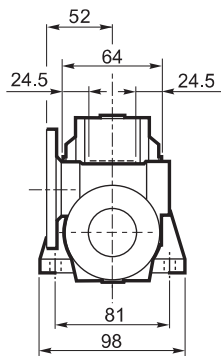

V

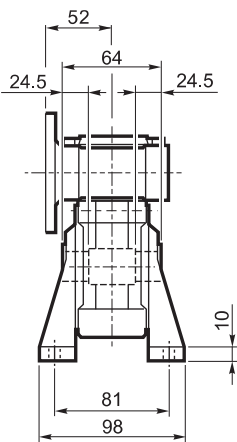

P

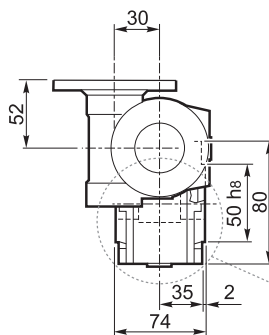
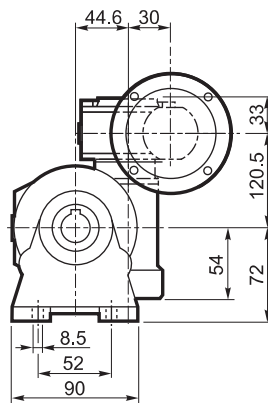
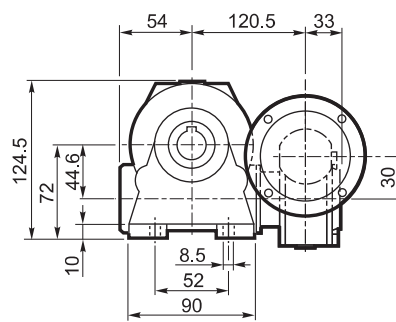
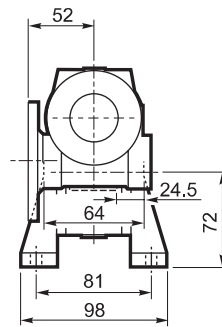
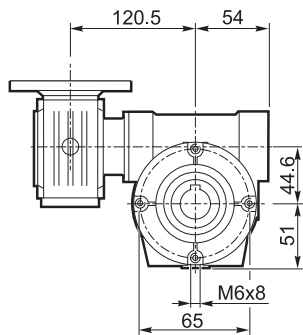

INPUT

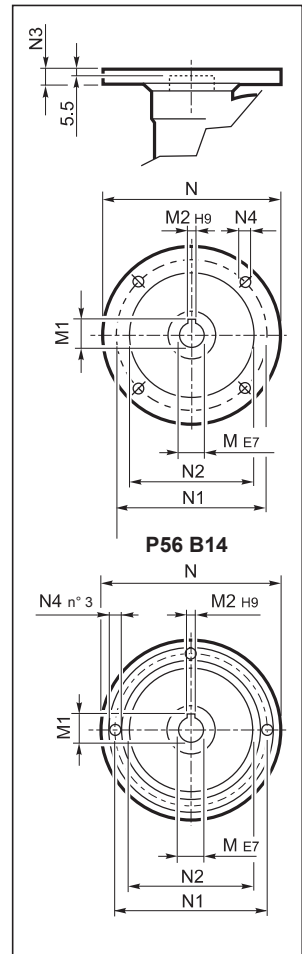

OUTPUT

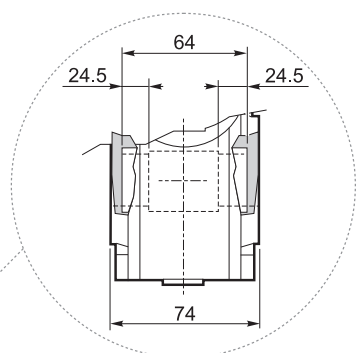
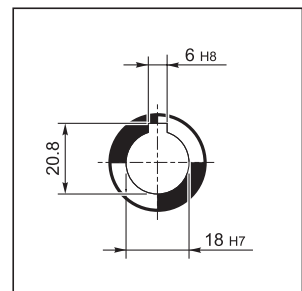



VF/VF 30/44...P (IEC)

F_

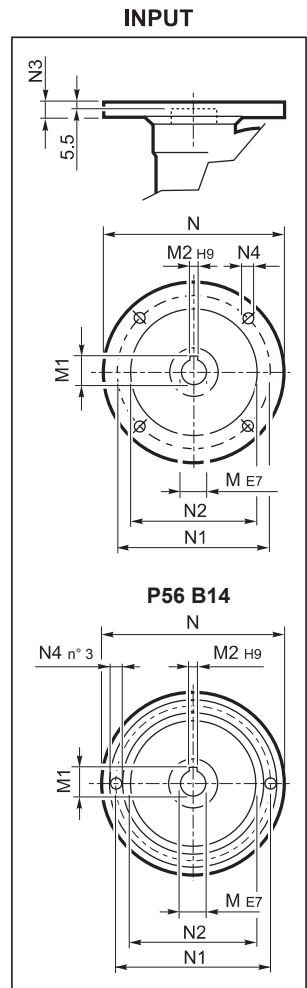
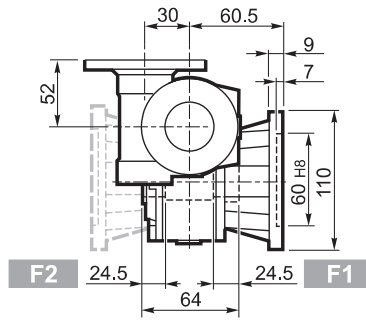
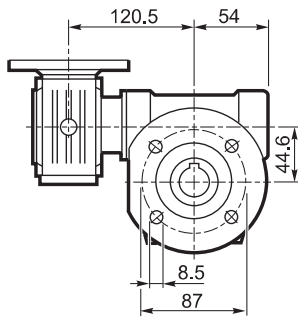

FA_

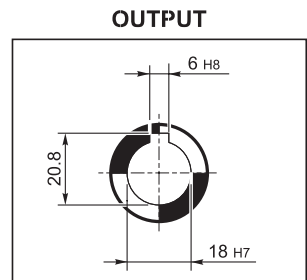
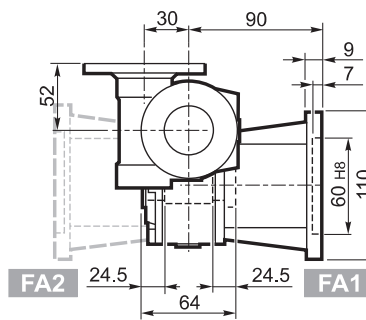
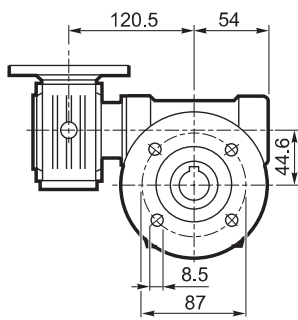

U

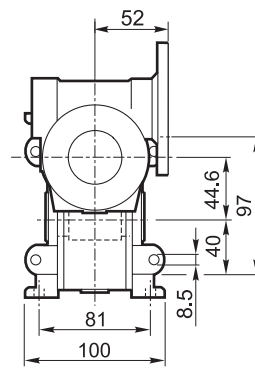
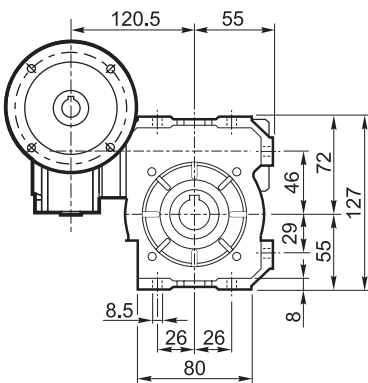

		M	M1	M2	N	N1	N2	N3	N4	
VF/VF 30/44	P56 B14	9	10.4	3	80	65	50	7	5.5	3.5
VF/VF 30/44	P63 B14	11	12.8	4	90	75	60	6	5.5	



VF 49...P (IEC)

A

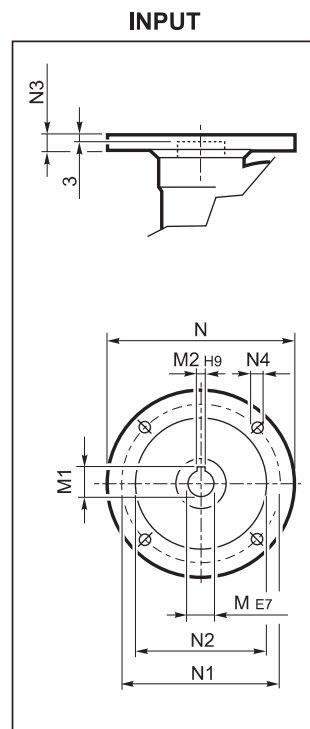
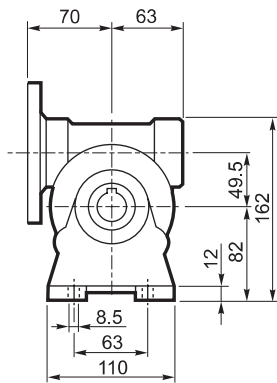
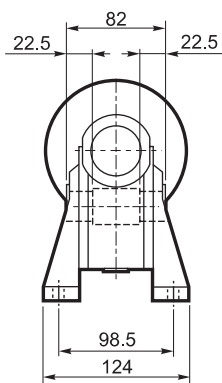

N

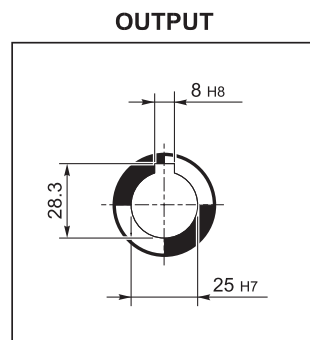
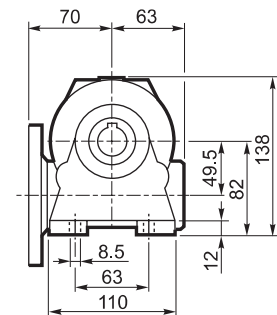
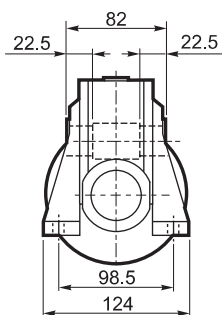

V

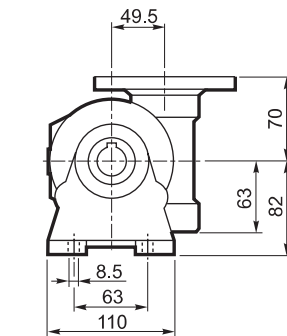
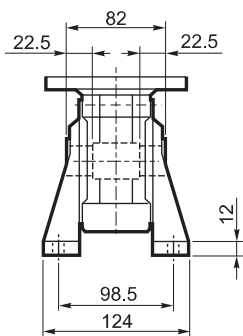

P

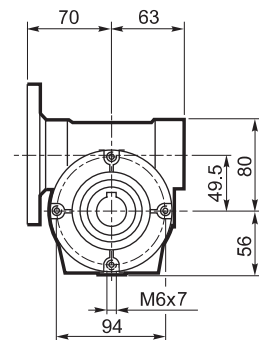
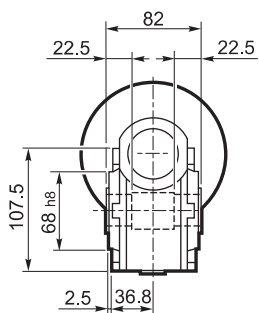



VF 49...P (IEC)

F_

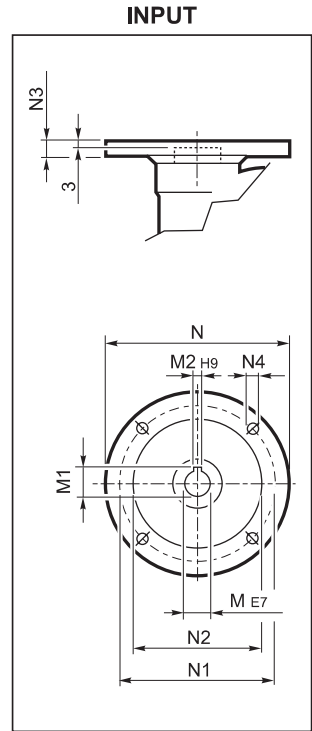
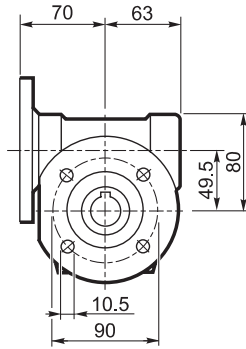
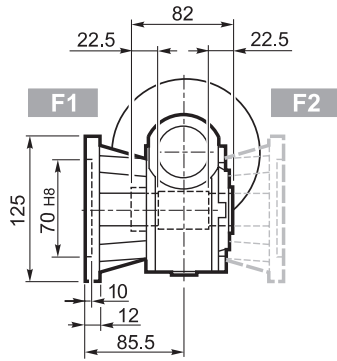

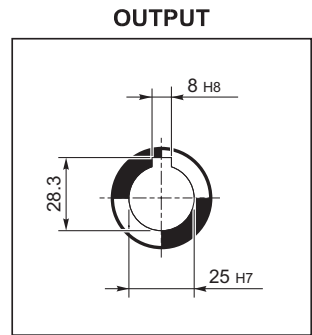
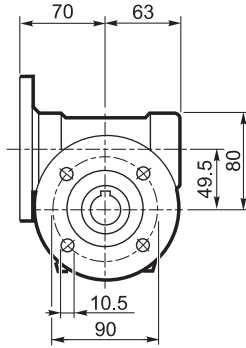
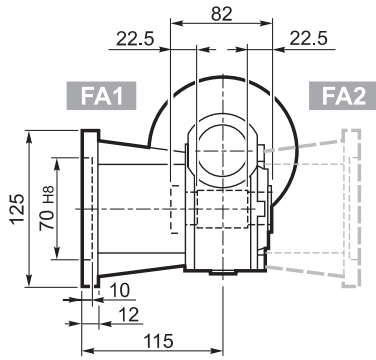

FA_

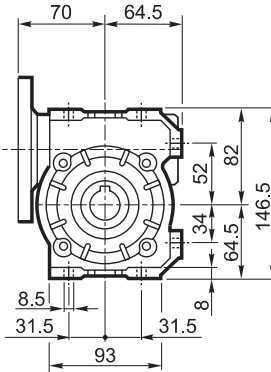
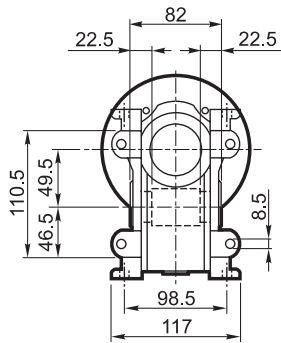

U



		M	M1	M2	N	N1	N2	N3	N4	
VF 49	P63 B5	11	12.8	4	140	115	95	10.5	9.5	3.0
VF 49	P71 B5	14	16.3	5	160	130	110	10.5	9.5	
VF 49	P80 B5	19	21.8	6	200	165	130	10	11.5	
VF 49	P63 B14	11	12.8	4	90	75	60	7	6	
VF 49	P71 B14	14	16.3	5	105	85	70	10.5	6.5	
VF 49	P80 B14	19	21.8	6	120	100	80	10	7	



VFR 49...P (IEC)

A

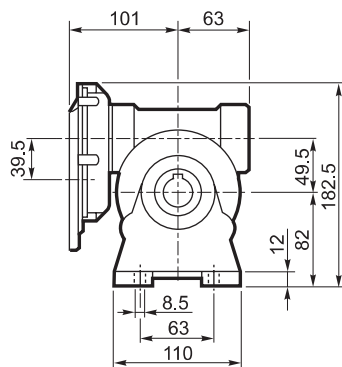
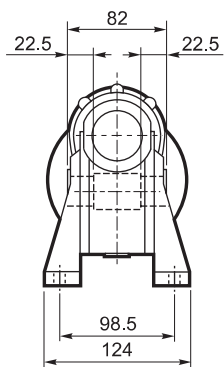

INPUT

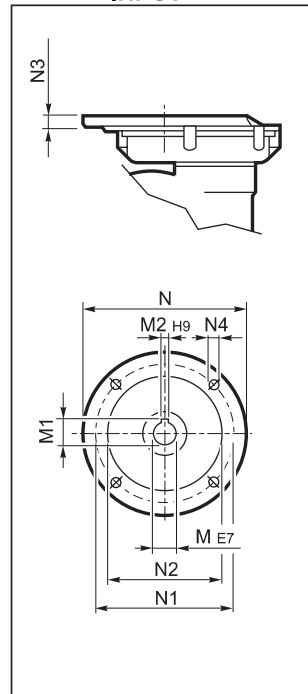

N

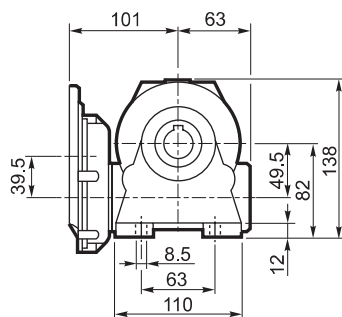
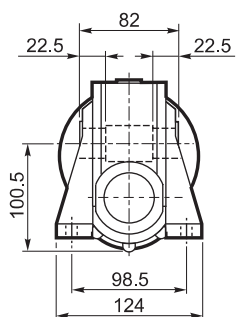

OUTPUT

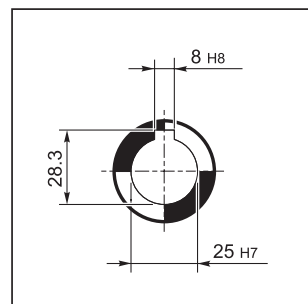

V

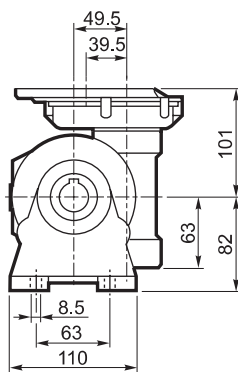
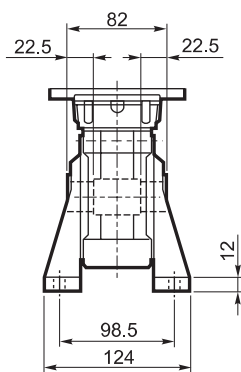

P

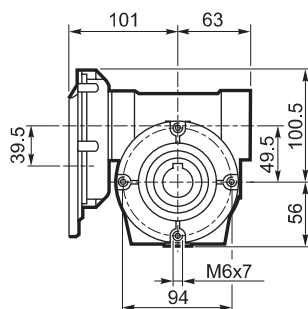
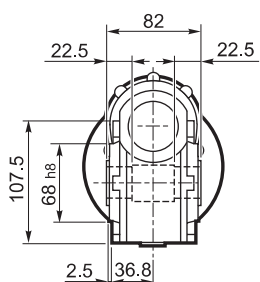



VFR 49...P (IEC)

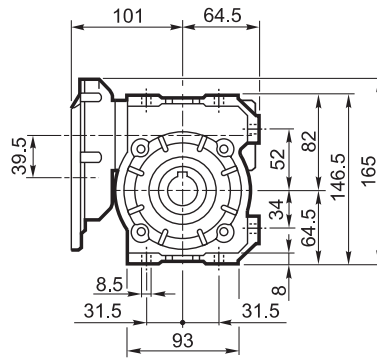
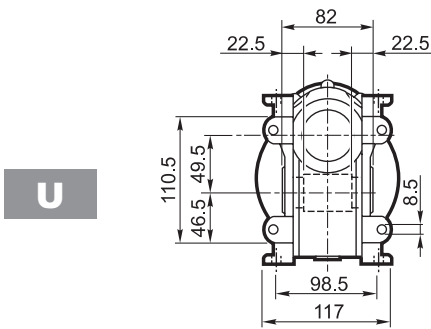
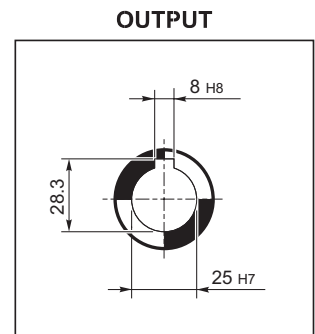
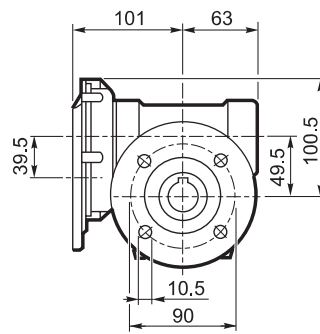
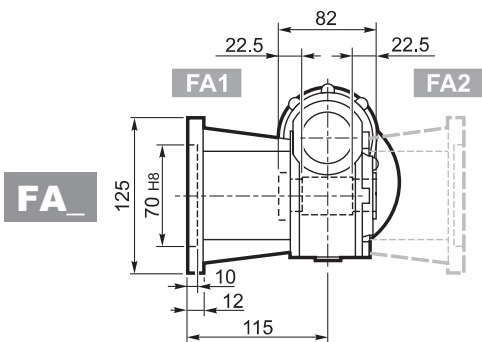
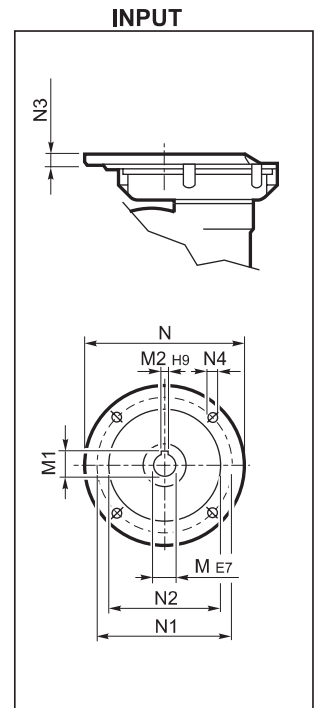
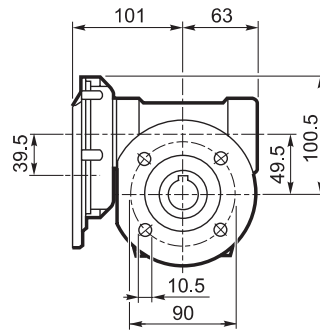
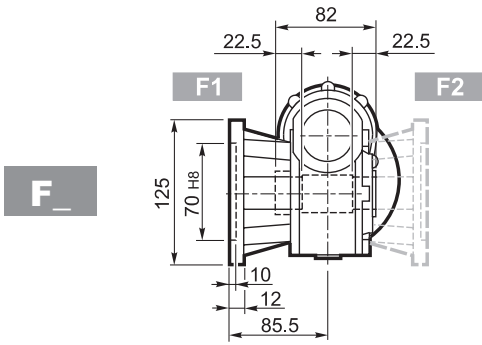

		M	M1	M2	N	N1	N2	N3	N4	
VFR 49	P63 B5	11	12.8	4	140	115	95	11	M8 x 19	5.0

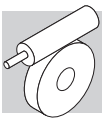

VF/VF 30/49...P (IEC)

A

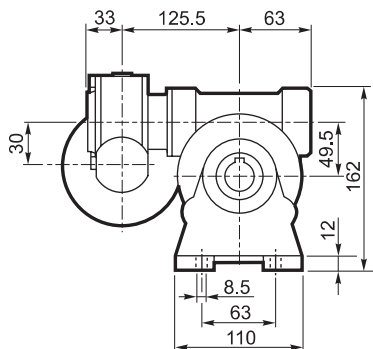

N

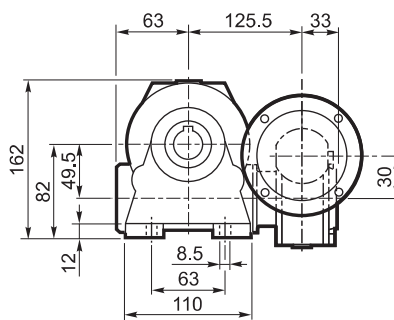
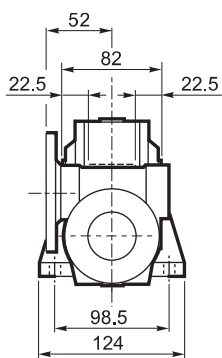

V

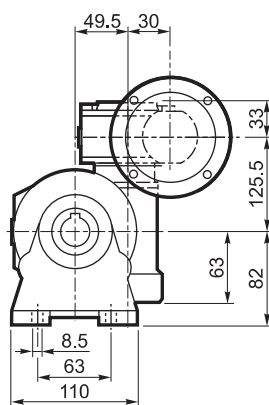
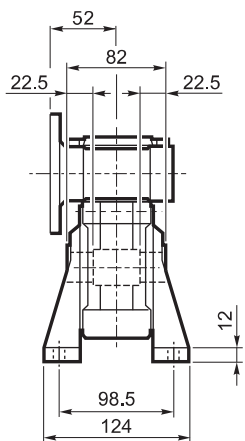

P

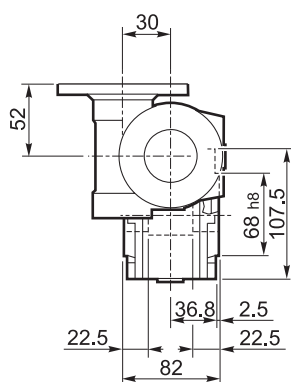
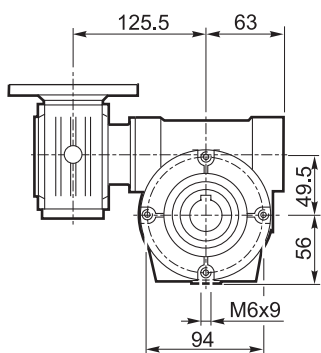

INPUT

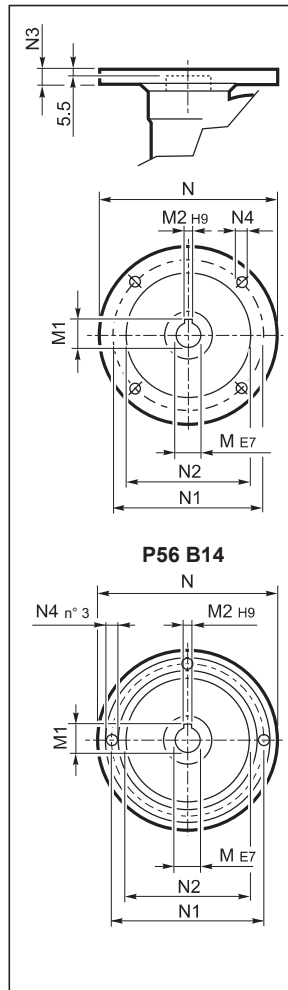

OUTPUT

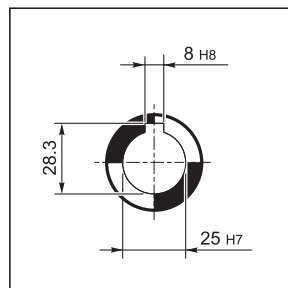

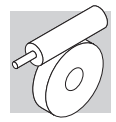

VF/VF 30/49...P (IEC)

F

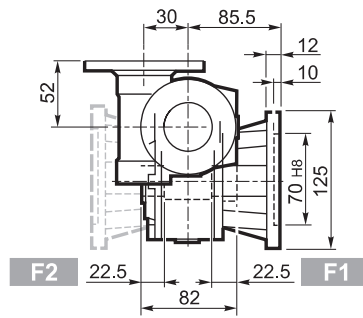
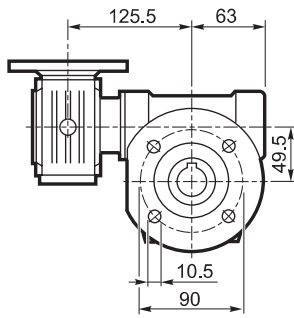

FA

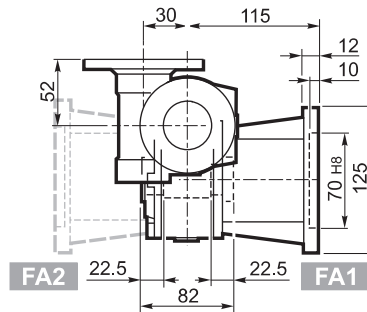
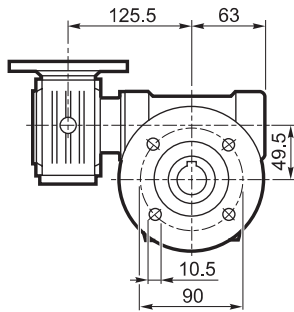

U

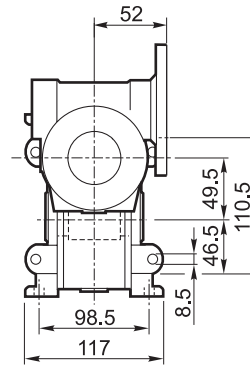
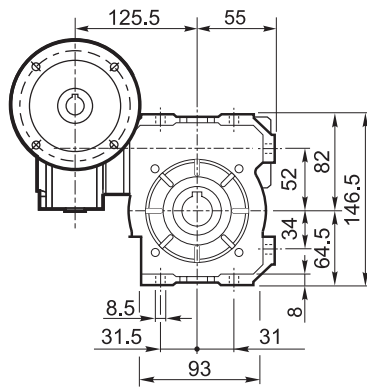

INPUT

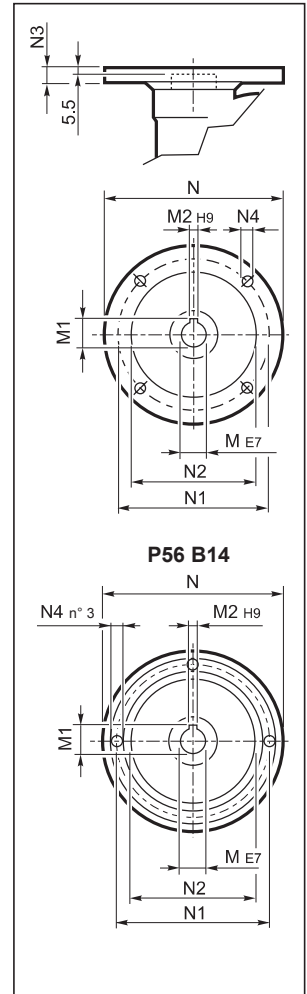

OUTPUT

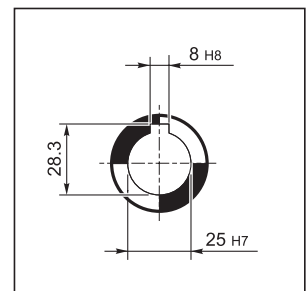

		M	M1	M2	N	N1	N2	N3	N4	
VF/VF 30/49	P56 B14	9	10.4	3	80	65	50	7	5.5	4.5
VF/VF 30/49	P63 B14	11	12.8	4	90	75	60	6	5.5	

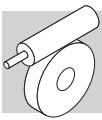

W 63...M/ME/MX/MXN

U

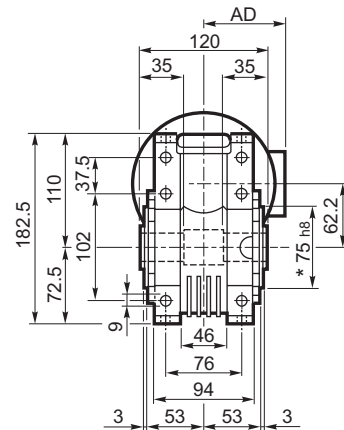
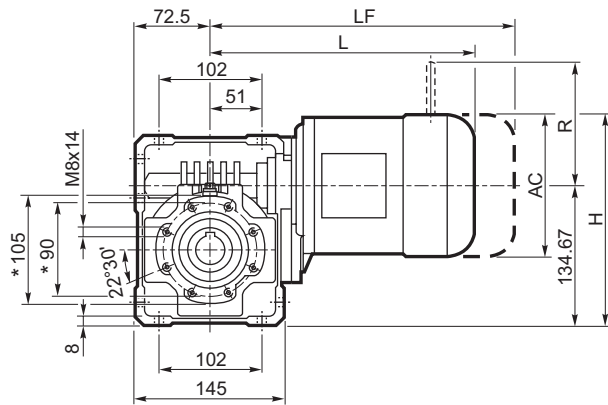



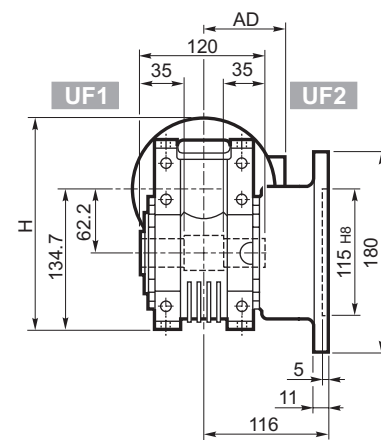
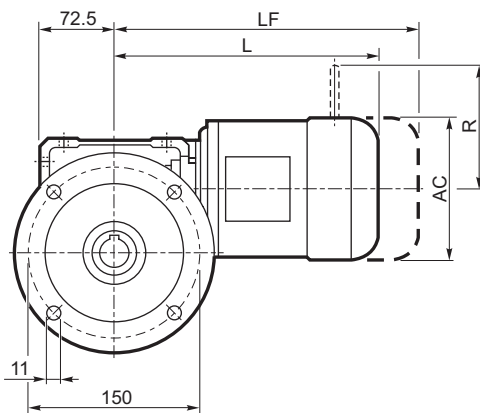

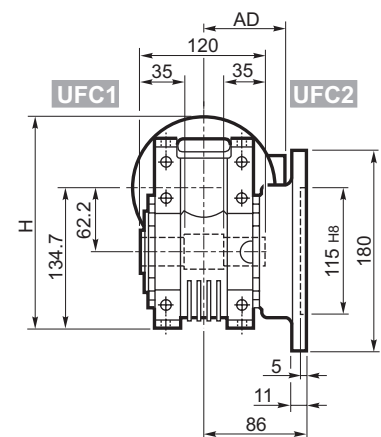
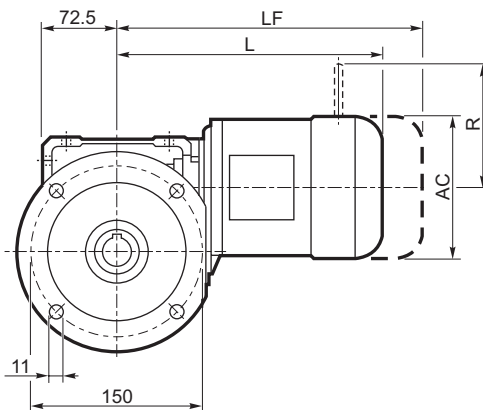

UF_



UFC_



	M/ME/MX/MXN							M...FD M...FA		M...FD		M...FA	
	AC	H	L	AD	Kg	LF	Kg	R	AD	R	AD		
 W 63 S1 M1	138	204	289	108	13	350	15	103	135	124	108		
 W 63 S1 ME1	138	204	289	108	13	411	15	103	135	124	135		
 W 63 S10 MXN10	138	204	318	138	15.4	409	17.4	103	138	1214	138		
 W 63 S2 M2S	156	213	317	119	17	393	20	129	146	134	119		
 W 63 S2 ME2S	156	213	317	119	18.6	463	21.6	129	143	134	143		
 W 63 S2 MX2S	156	213	361	119	22.4	465	25.4	129	143	134	143		
 W 63 S20 MXN20	158	214	370.5	146	24.6	464	27.6	129	148	131	148		

OUTPUT

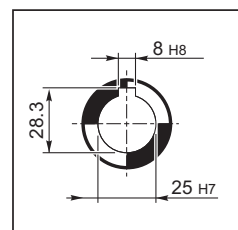

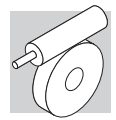

* Auf beiden seiten

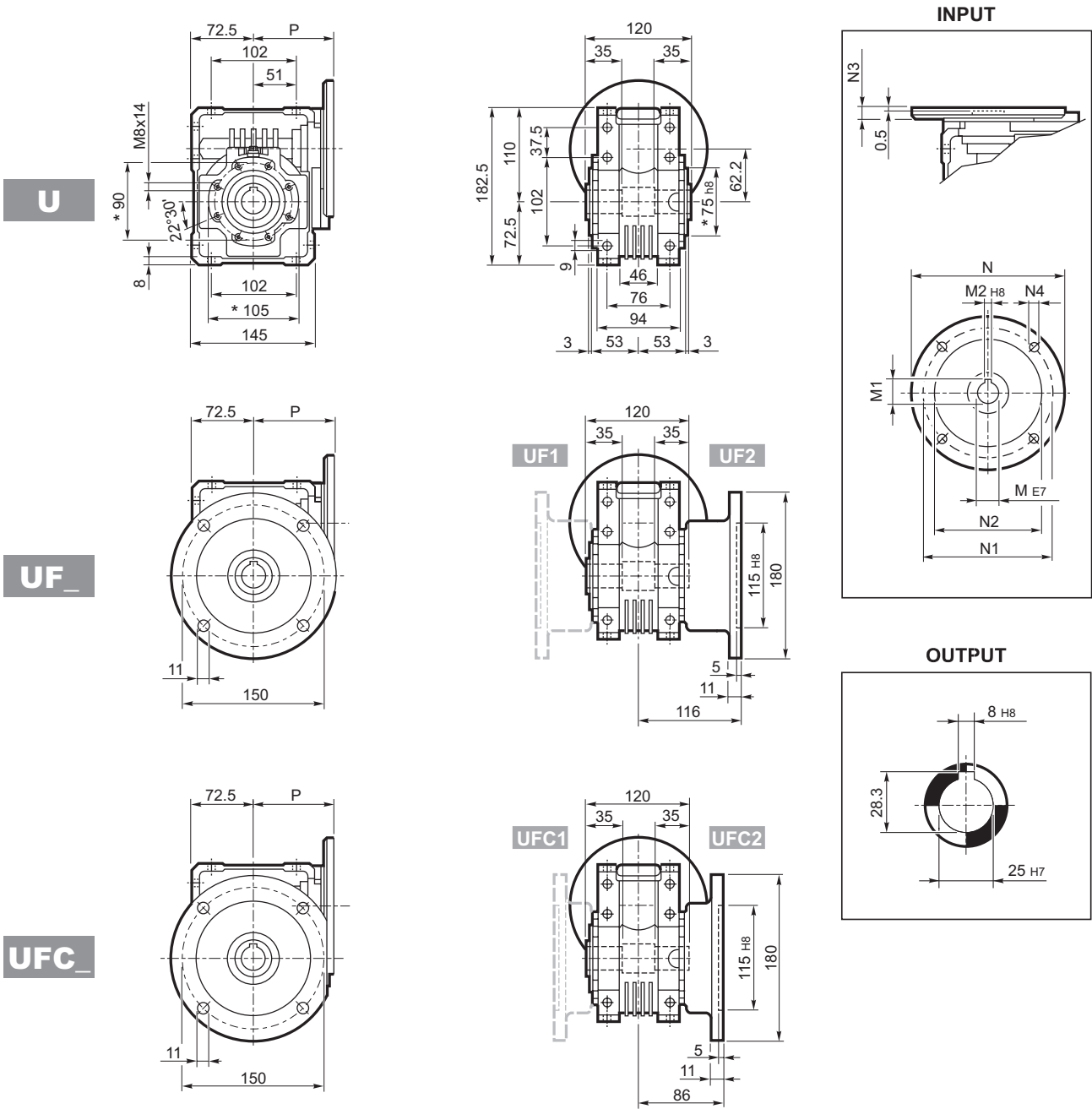

W 63...P (IEC)



		M	M1	M2	N	N1	N2	N3	N4	P	
W 63	P71 B5	14	16.3	5	160	130	110	11	9	95	6.3
W 63	P80 B5	19	21.8	6	200	165	130	12	11.5	102	6.5
W 63	P90 B5	24	27.3	8	200	165	130	12	11.5	102	6.4
W 63	P71 B14	14	16.3	5	105	85	70	11	6.5	95	6.1
W 63	P80 B14	19	21.8	6	120	100	80	11	6.5	102	6.3
W 63	P90 B14	24	27.3	8	140	115	95	11	8.5	102	6.3

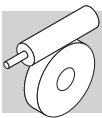

WR 63...P (IEC)

U

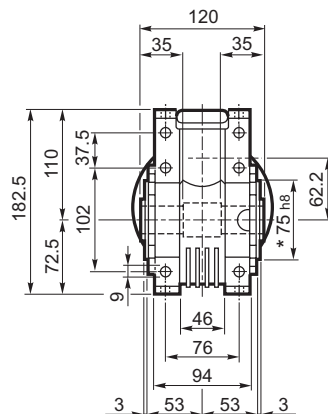
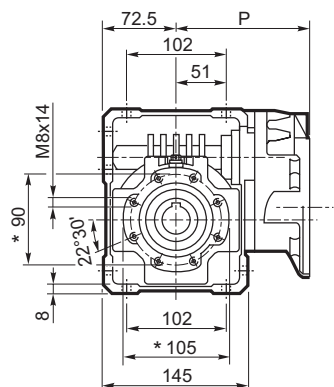

INPUT

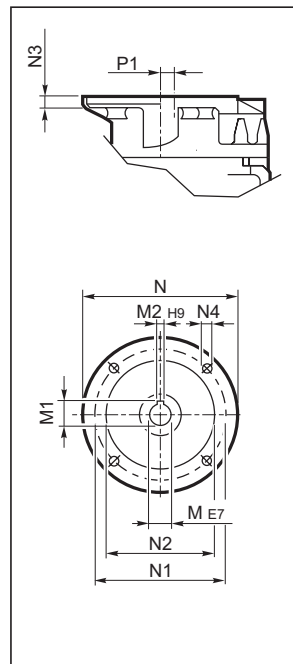

UF_

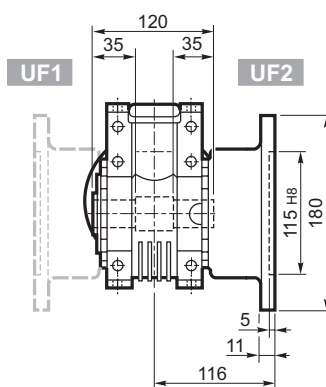
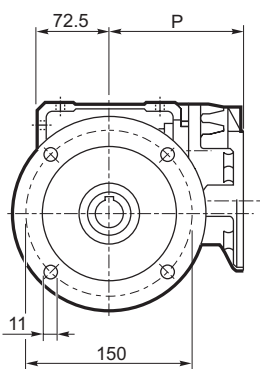

OUTPUT

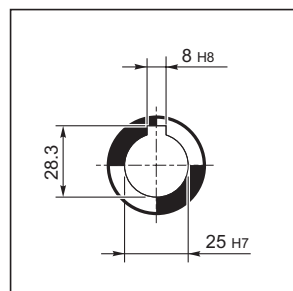

UFC_

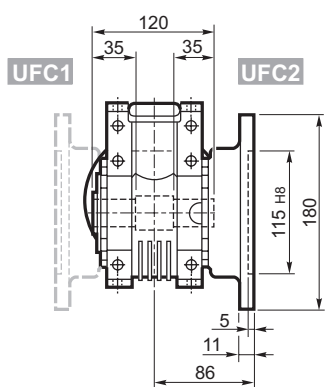
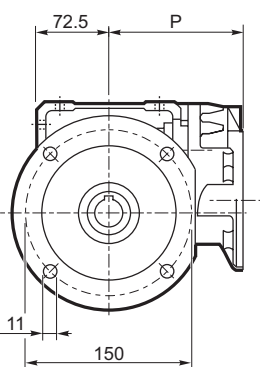

		M	M1	M2	N	N1	N2	N3	N4	P	P1	
WR 63	P63 B5	11	12.8	4	140	115	95	10	M8x10	133.5	11.42	7.1
WR 63	P71 B5	14	16.3	5	160	130	110	10	M8x10	133.5	11.42	

* Auf beiden seiten

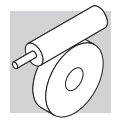

VF/W 30/63...P (IEC)

U

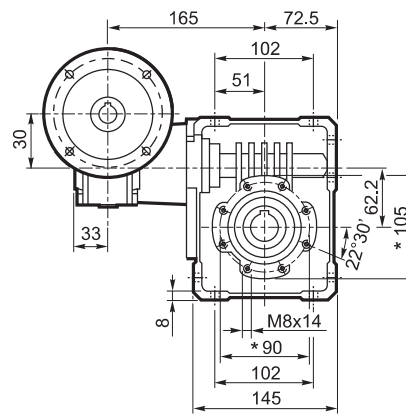
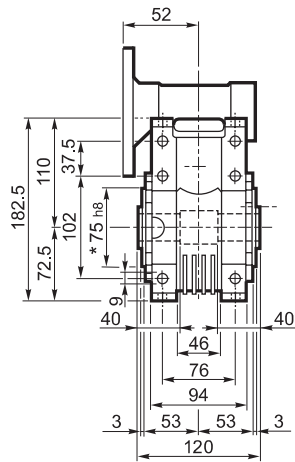

INPUT

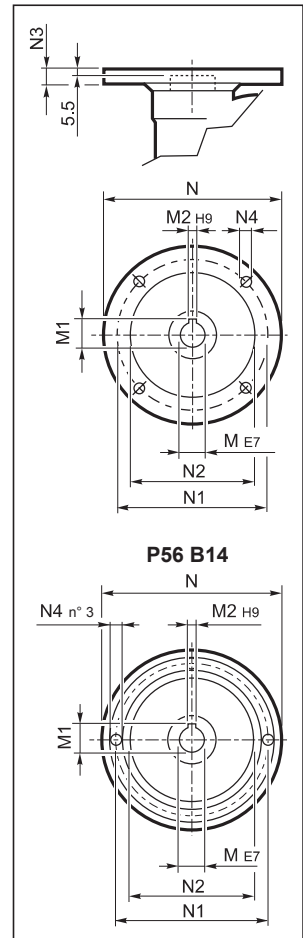

UF_

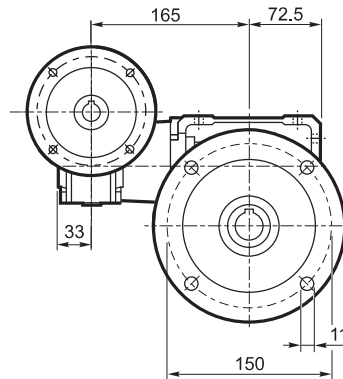
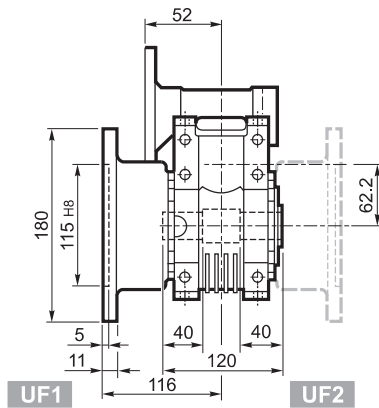

UFC_

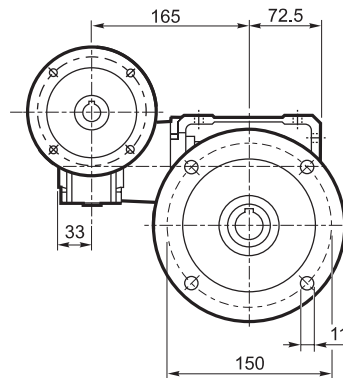
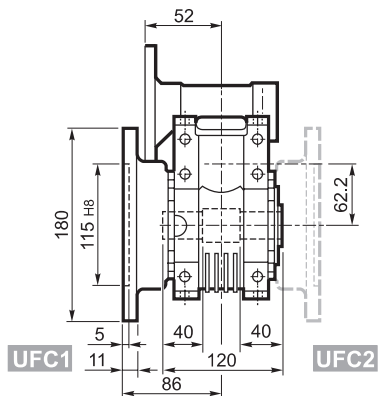

OUTPUT

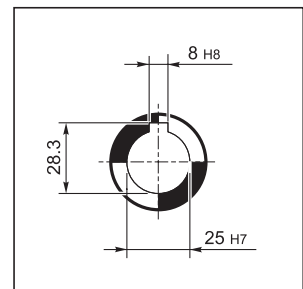

		M	M1	M2	N	N1	N2	N3	N4	
VF/W 30/63	P56 B5	9	10.4	3	120	100	80	7	7	8.0
VF/W 30/63	P63 B5	11	12.8	4	140	115	95	8	9.5	
VF/W 30/63	P56 B14	9	10.4	3	80	65	50	7	5.5	
VF/W 30/63	P63 B14	11	12.8	4	90	75	60	6	5.5	

* Auf beiden seiten

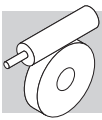

W 75...M/ME/MX/MXN

U

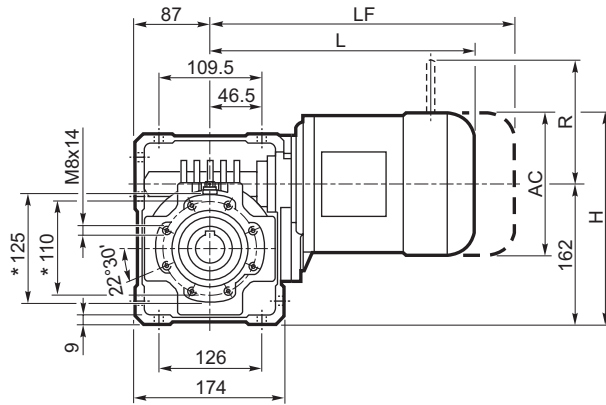

UF_

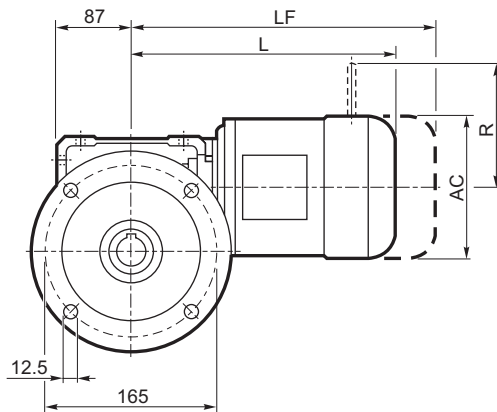

UFC_

UFCR_#

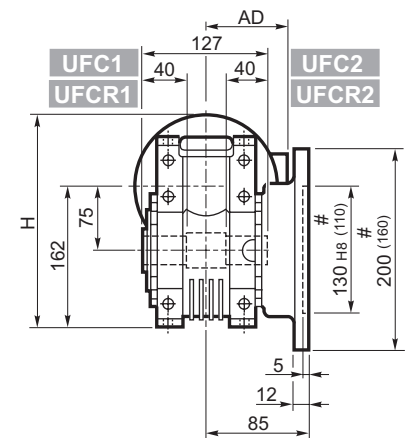
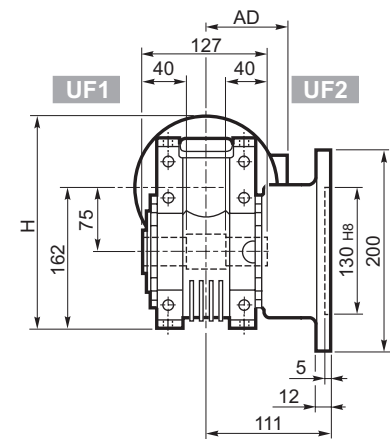
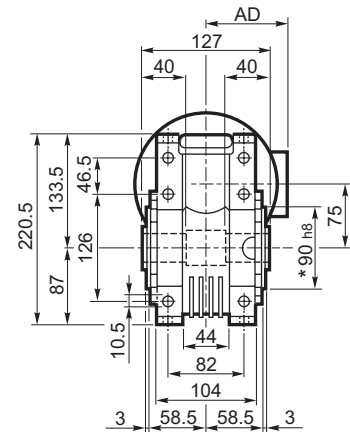
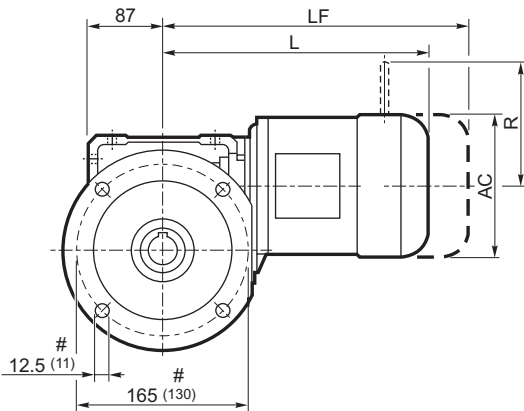

STANDARD OUTPUT

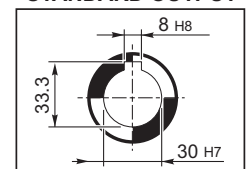

ON REQUEST OUTPUT

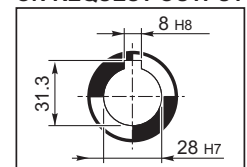

			M/ME/MX/MXN					M...FD M...FA		M...FD		M...FA	
			AC	H	L	AD	Kg	LF	Kg	R	AD	R	AD
W 75	S1	M1	138	231	308	108	16.0	369	18.2	103	135	124	108
W 75	S1	ME1	138	231	308	108	16.0	369	18.2	103	135	124	135
W 75	S10	MXN10	138	231	337	137	18.4	396	20.8	103	138	121	138
W 75	S2	ME2S	156	240	333	119	18.5	393	20.1	129	143	134	143
W 75	S2	MX2S	156	240	377	119	23.6	465	27.4	129	143	134	143
W 75	S20	MXN20	158	241	386.5	146	25.8	457.5	28	129	148	131	148
W 75	S3	ME3S	195	258.5	376	142	27.1	447	33.1	160	155	160	155
W 75	S3	MX3S	195	258.5	408	142	31.1	476	38.1	160	155	160	155
W 75	S3	ME3L	195	258.5	408	142	32.6	474	38.6	160	155	160	155
W 75	S3	MX3L	195	258.5	452	142	38.6	518	45.6	160	155	160	155

* Auf beiden seiten

Verkürzte Flansch

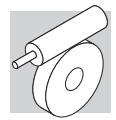

W 75...P (IEC)

U

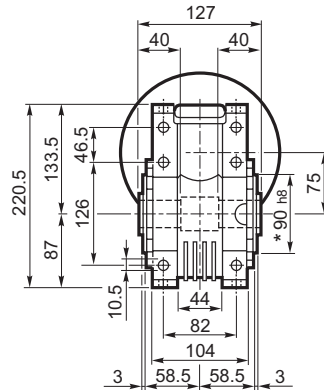
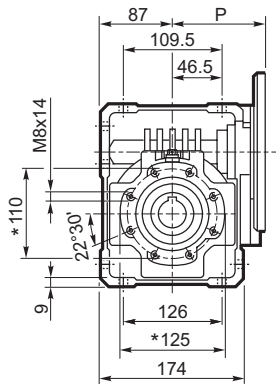

INPUT

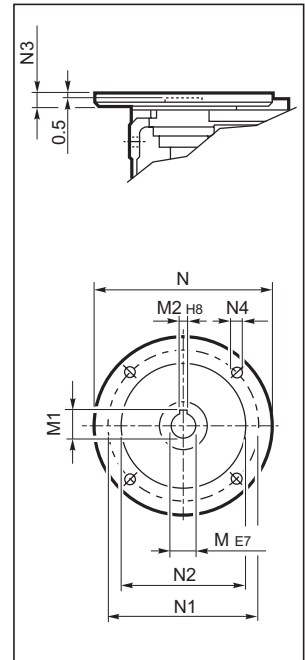

UF_

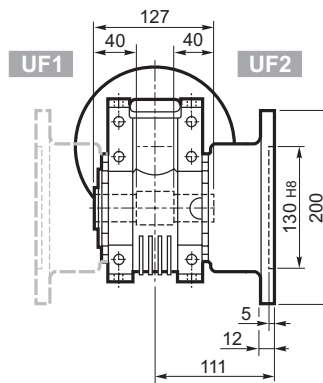
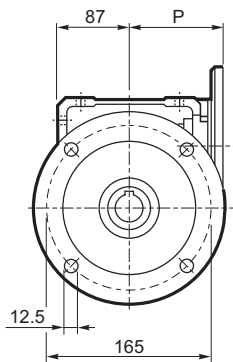

STANDARD OUTPUT

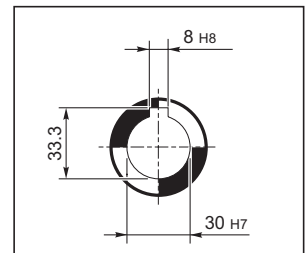

UFC_

UFCR_#

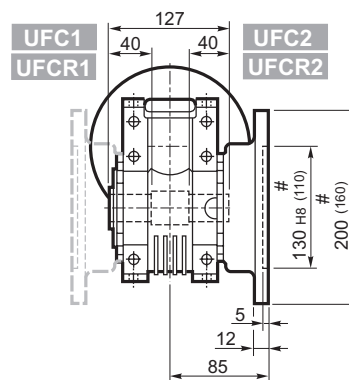
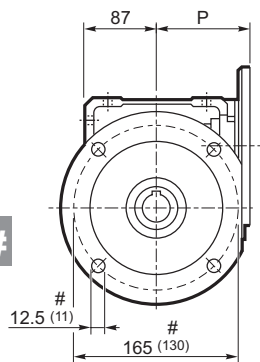

ON REQUEST OUTPUT

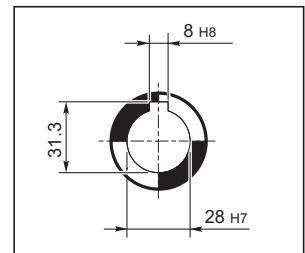

		M	M1	M2	N	N1	N2	N3	N4	P	
W 75	P71 B5	14	16.3	5	160	130	110	11	9	112	9.5
W 75	P80 B5	19	21.8	6	200	165	130	12	11.5	112	9.7
W 75	P90 B5	24	27.3	8	200	165	130	12	11.5	112	9.6
W 75	P100 B5	28	31.3	8	250	215	180	13	12.5	120	9.7
W 75	P112 B5	28	31.3	8	250	215	180	13	12.5	120	9.7
W 75	P80 B14	19	21.8	6	120	100	80	7.5	6.5	112	9.4
W 75	P90 B14	24	27.3	8	140	115	95	7.5	8.5	112	9.4
W 75	P100 B14	28	31.3	8	160	130	110	10	8.5	120	9.5
W 75	P112 B14	28	31.3	8	160	130	110	10	8.5	120	9.5

* Auf beiden Seiten

Verkürzte Flansch

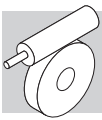

WR 75...P (IEC)

U

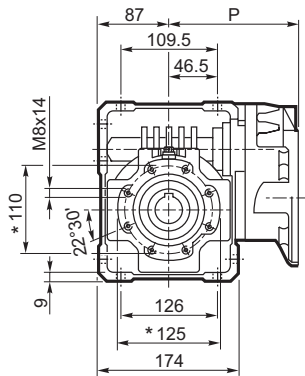

UF_

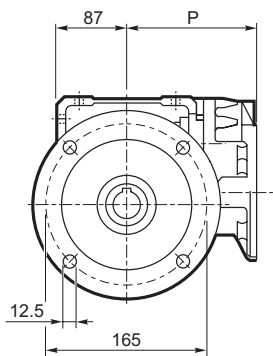

UFC_

UFCR_#

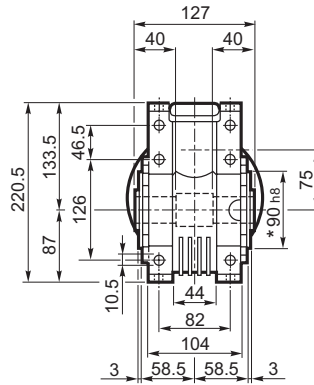
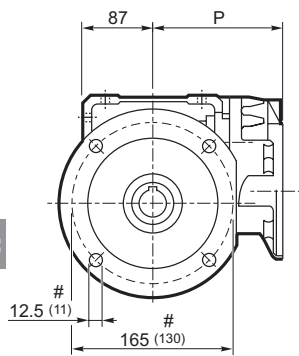

UF1

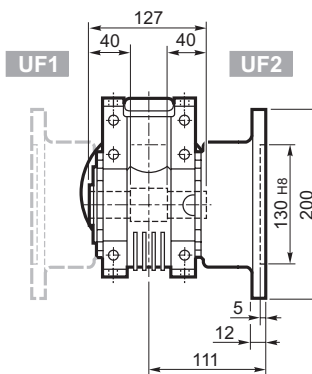

UF2

UFC1
UFCR1

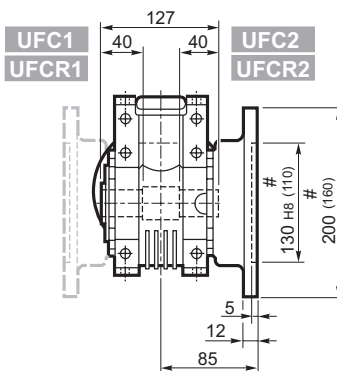

UFC2
UFCR2

INPUT

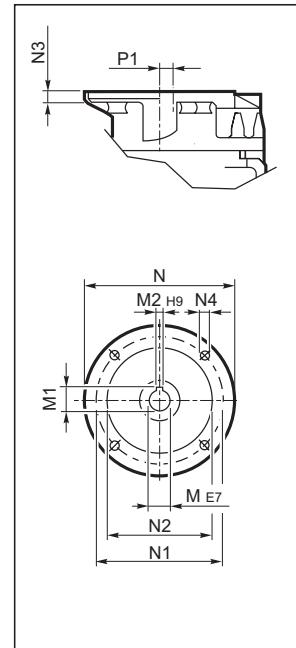

STANDARD OUTPUT

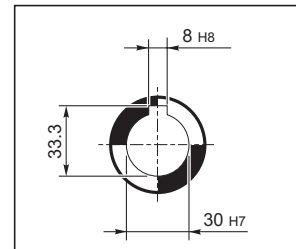

ON REQUEST OUTPUT

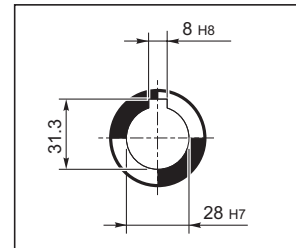

		M	M1	M2	N	N1	N2	N3	N4	P	P1	
WR 75	P63 B5	11	12.8	4	140	115	95	10	M8x10	152	23.53	10.6
WR 75	P71 B5	14	16.3	5	160	130	110	10	M8x10	152	23.53	10.7
WR 75	P80 B5	19	21.8	6	200	165	130	12	M10x13	163.5	11	11.5
WR 75	P90 B5	24	27.3	8	200	165	130	12	M10x13	163.5	11	11.6

* Auf beiden seiten

Verkürzte Flansch

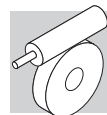

VF/W 44/75...P (IEC)

U

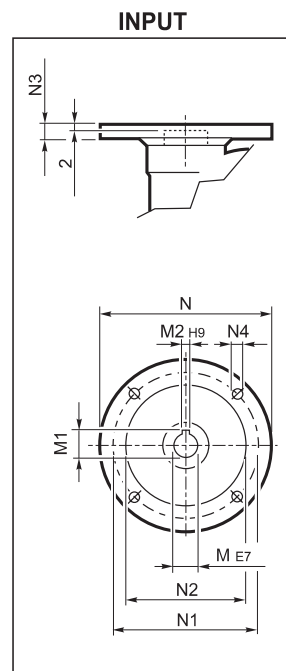
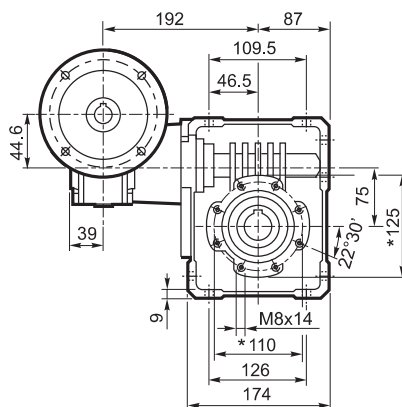
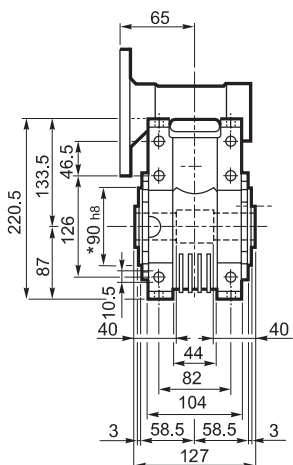

UF

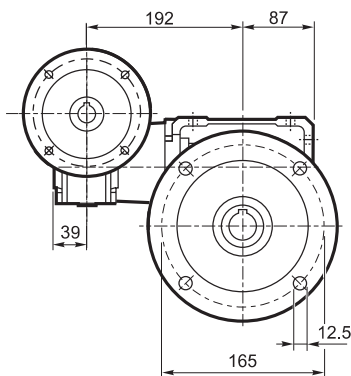
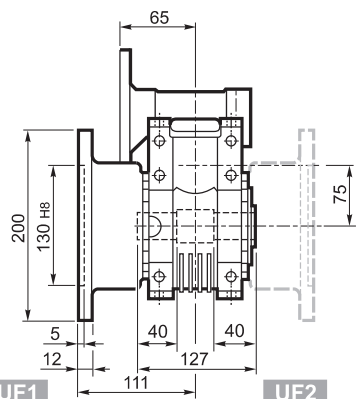

STANDARD OUTPUT

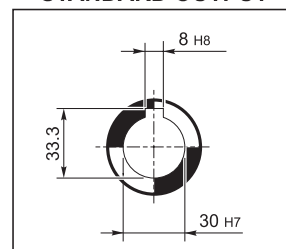

UFC

UFCR #

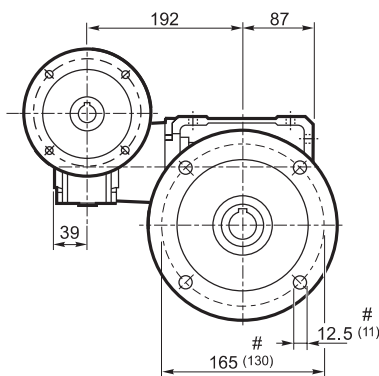
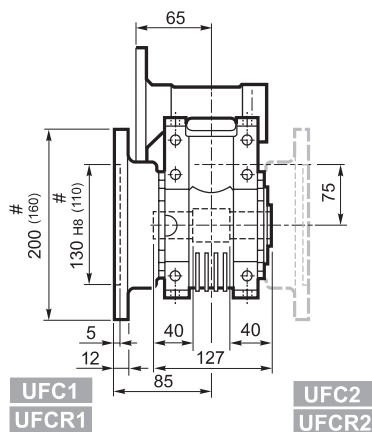

ON REQUEST OUTPUT

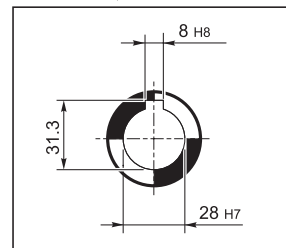

		M	M1	M2	N	N1	N2	N3	N4	Kg
VF/W 44/75	P63 B5	11	12.8	4	140	115	95	10	9.5	12.5
VF/W 44/75	P71 B5	14	16.3	5	160	130	110	10	9.5	
VF/W 44/75	P63 B14	11	12.8	4	90	75	60	8	5.5	
VF/W 44/75	P71 B14	14	16.3	5	105	85	70	10	7	

* Auf beiden seiten

Verkürzte Flansch

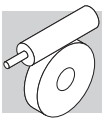

W 86...M/ME/MX/MXN

U

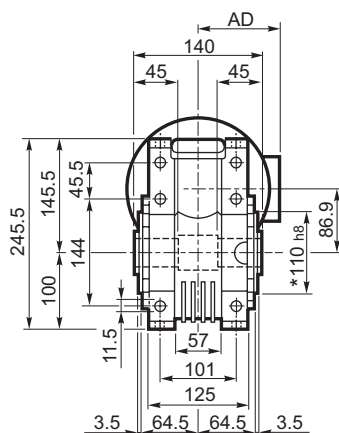
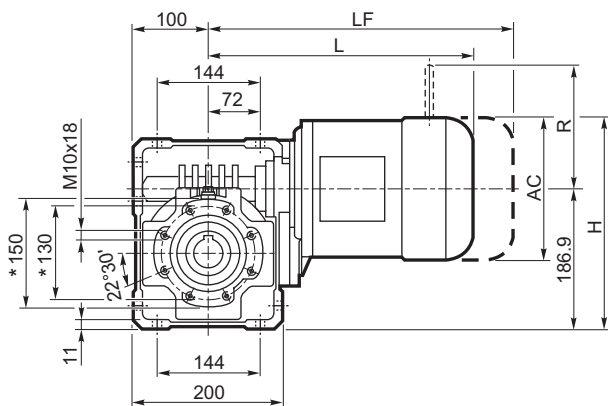

UF_

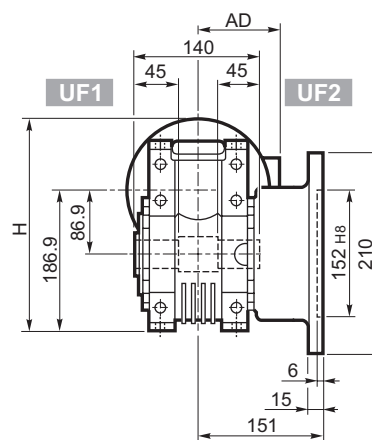
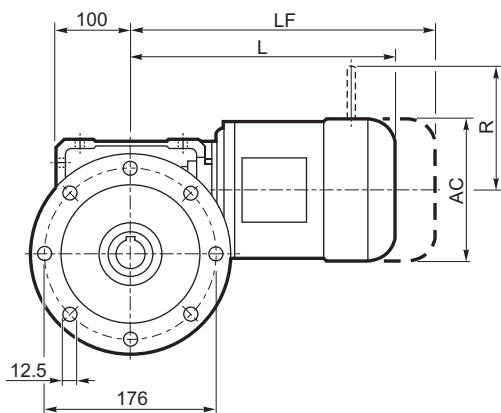

UFC_

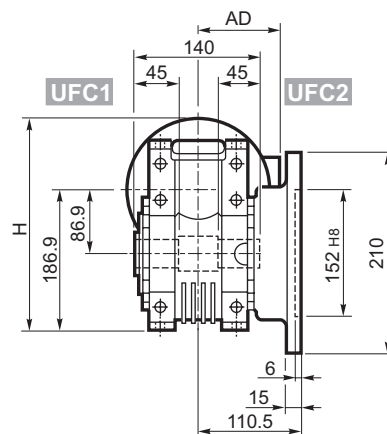
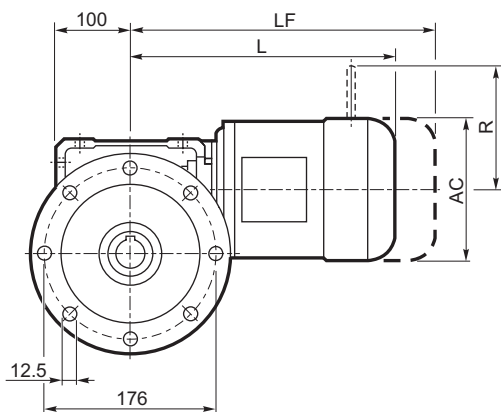

			M/ME/MX/MXN					M...FD M...FA		M...FD		M...FA	
			AC	H	L	AD	Kg	LF	Kg	R	AD	R	AD
W 86	S1	M1	138	256	324	108	20.1	385	22.3	103	135	124	108
W 86	S1	ME1	138	256	324	108	20.1	385	22.3	103	135	124	135
W 86	S10	MXN10	138	256	353	137	22.5	412	25.2	103	138	121	138
W 86	S2	M2S	156	265	349	119	22.6	425	25.7	129	146	134	119
W 86	S2	ME2S	156	265	349	119	24.2	410	25.8	129	143	134	143
W 86	S2	MX2S	156	265	393	119	27.7	465	31.5	129	143	134	143
W 86	S20	MXN20	158	266	402.5	146	29.9	473.5	33.8	129	148	131	148
W 86	S3	ME3S	195	283.5	392	142	31.2	488	37.8	160	155	160	155
W 86	S3	MX3S	195	283.5	424	142	34.2	514	41.2	160	155	160	155
W 86	S3	ME3L	195	283.5	424	142	36.7	515	42.7	160	155	160	155
W 86	S3	MX3L	195	283.5	468	142	42.7	560	49.7	160	155	160	155

* Auf beiden Seiten

OUTPUT

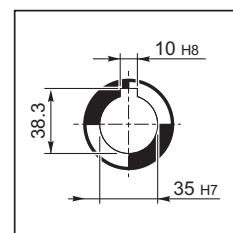

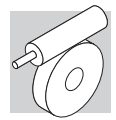

W 86...P (IEC)

U

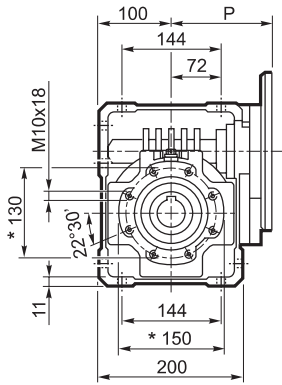

UF_

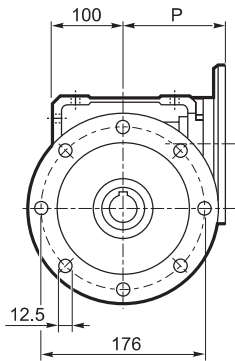

UFC_

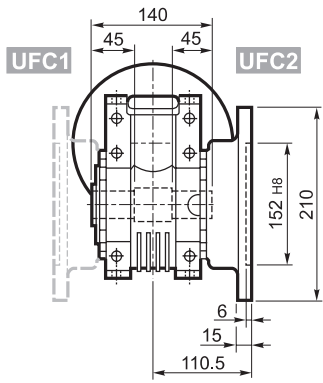
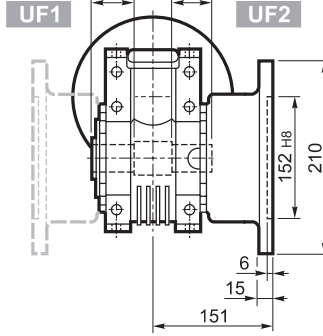
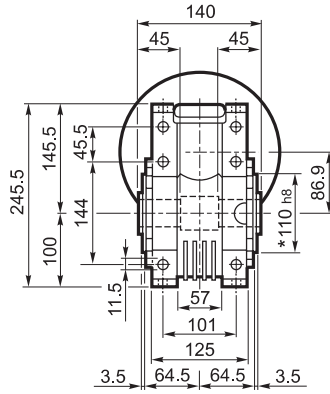
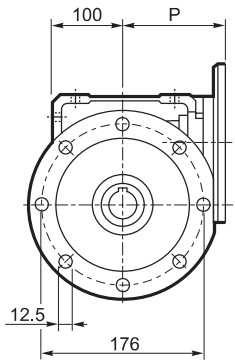

INPUT

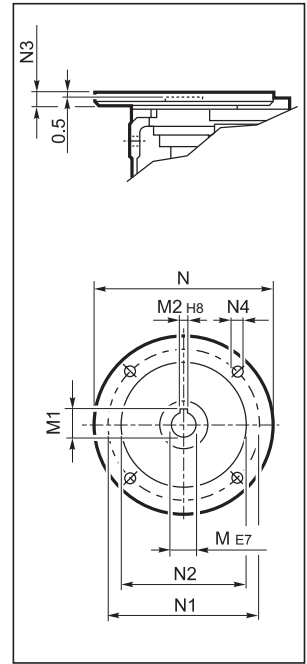

OUTPUT

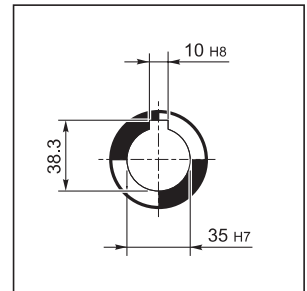

		M	M1	M2	N	N1	N2	N3	N4	P	
W 86	P71 B5	14	16.3	5	160	130	110	11	9	128	13.6
W 86	P80 B5	19	21.8	6	200	165	130	12	11.5	128	13.8
W 86	P90 B5	24	27.3	8	200	165	130	12	11.5	128	13.7
W 86	P100 B5	28	31.3	8	250	215	180	13	12.5	136	13.8
W 86	P112 B5	28	31.3	8	250	215	180	13	12.5	136	13.8
W 86	P80 B14	19	21.8	6	120	100	80	7.5	6.5	128	13.5
W 86	P90 B14	24	27.3	8	140	115	95	7.5	8.5	128	13.5
W 86	P100 B14	28	31.3	8	160	130	110	10	8.5	136	13.6
W 86	P112 B14	28	31.3	8	160	130	110	10	8.5	136	13.6

* Auf beiden Seiten

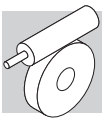

WR 86...P (IEC)

U

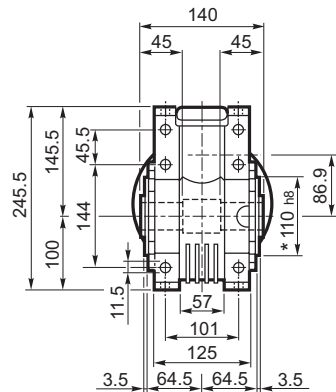
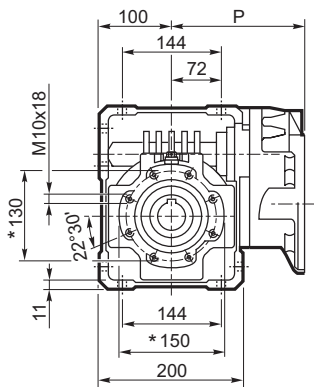

INPUT

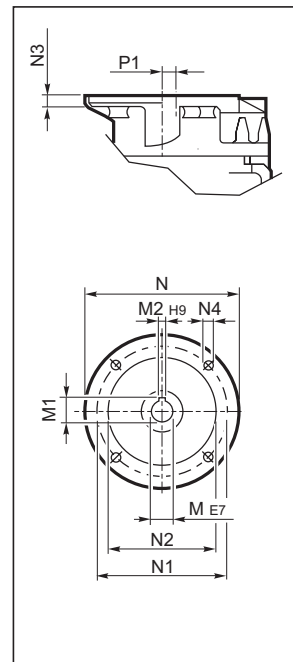

UF

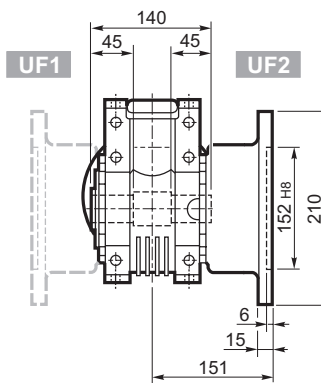
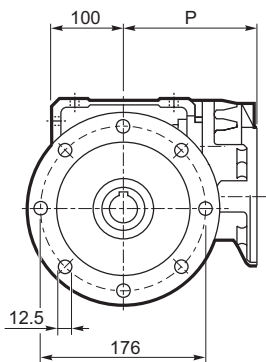

OUTPUT

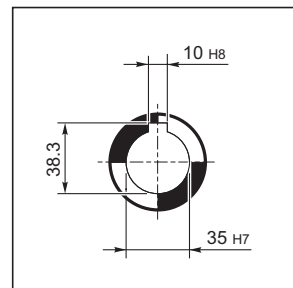

UFC

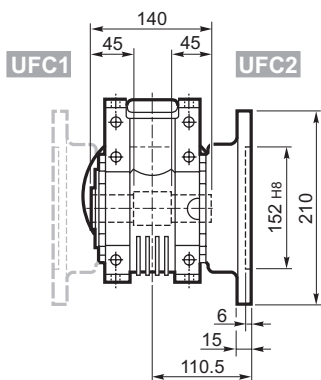
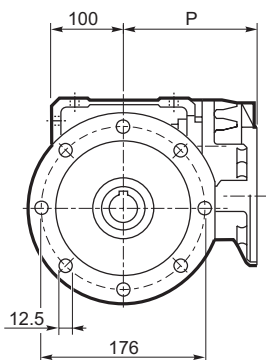

		M	M1	M2	N	N1	N2	N3	N4	P	P1	kg
		11	12.8	4	140	115	95	10	M8x10	168	35.4	14.3
WR 86	P71 B5	14	16.3	5	160	130	110	10	M8x10	168	35.4	14.4
WR 86	P80 B5	19	21.8	6	200	165	130	12	M10x13	179.5	22.9	15.2
WR 86	P90 B5	24	27.3	8	200	165	130	12	M10x13	179.5	22.9	15.3

* Auf beiden seiten

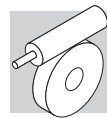

VF/W 44/86... P (IEC)

U

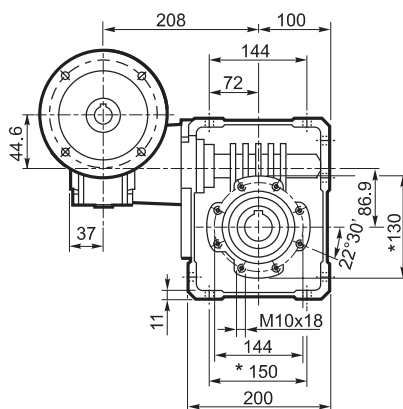
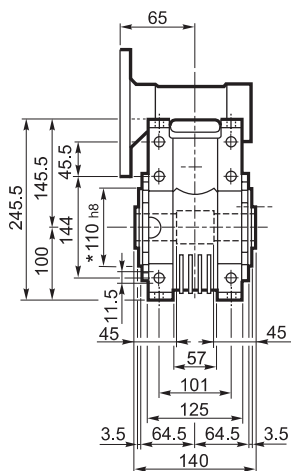

INPUT

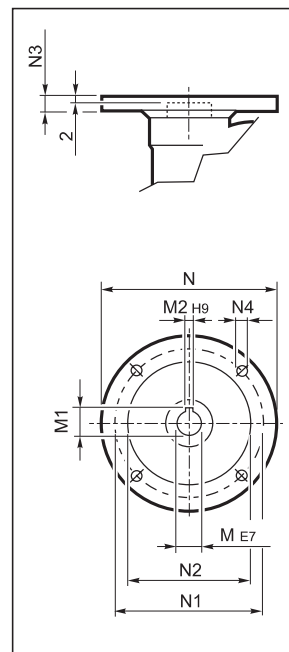

UF

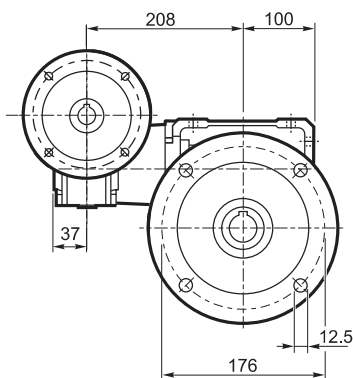
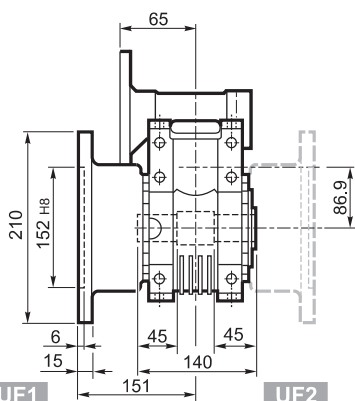

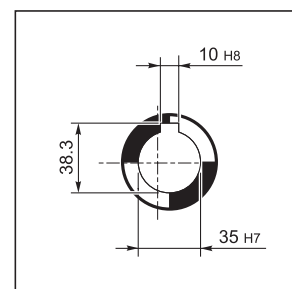

OUTPUT

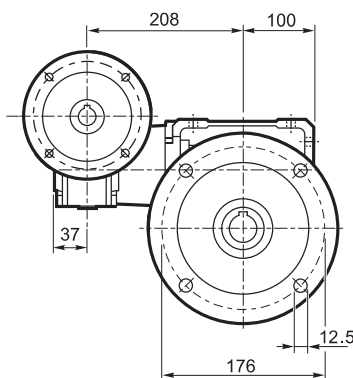
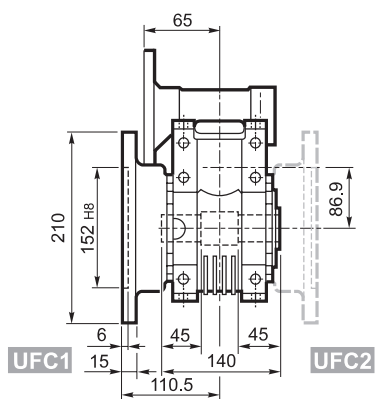

UFC



		M	M1	M2	N	N1	N2	N3	N4	
VF/W 44/86	P63 B5	11	12.8	4	140	115	95	10	9.5	16.6
VF/W 44/86	P71 B5	14	16.3	5	160	130	110	10	9.5	
VF/W 44/86	P63 B14	11	12.8	4	90	75	60	8	5.5	
VF/W 44/86	P71 B14	14	16.3	5	105	85	70	10	7	

* Auf beiden Seiten

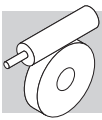

W 110...M/ME/MX

U

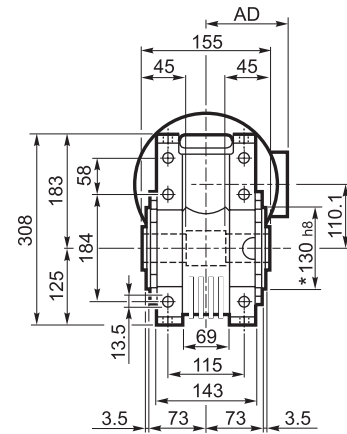
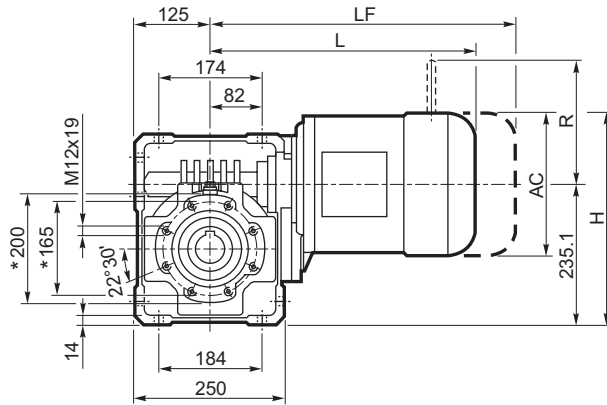

UF

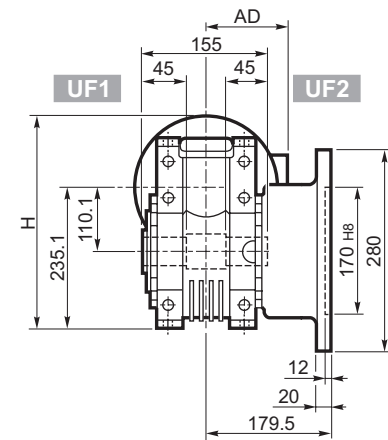
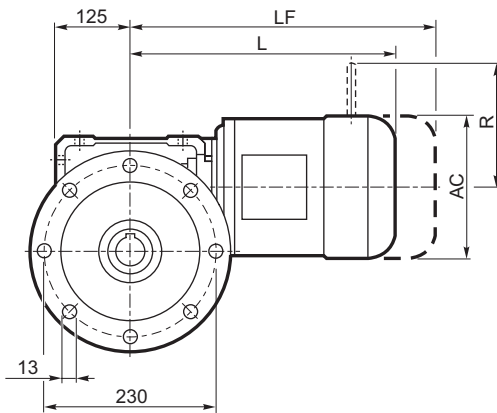

UFC

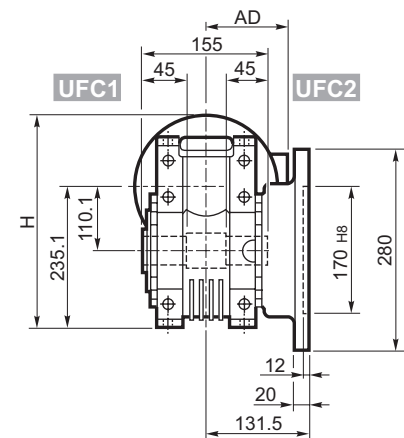
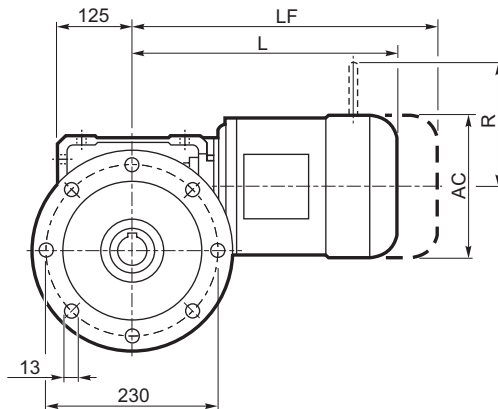

			M/ME/MX				Kg	M...FD M...FA		Kg	M...FD		M...FA	
			AC	H	L	AD		LF	R		AD	R	AD	
W 110	S2	M2S	156	313	364	119	38	440	41	129	146	134	119	
W 110	S2	ME2S	156	313	364	119	38	440	39.6	129	143	134	143	
W 110	S2	MX2S	156	313	408	119	43.1	480	46.9	129	143	134	143	
W 110	S3	ME3S	195	332	407	142	47.5	503	53.5	160	155	160	155	
W 110	S3	MX3S	195	332	440	142	50.5	530	57.5	160	155	160	155	
W 110	S3	ME3L	195	332	439	142	53	530	59	160	155	160	155	
W 110	S3	MX3L	195	332	483	142	59	575	66	160	155	160	155	

OUTPUT

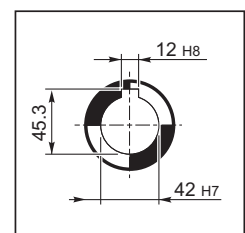

* Auf beiden Seiten

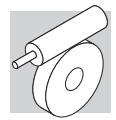

W 110...P (IEC)

U

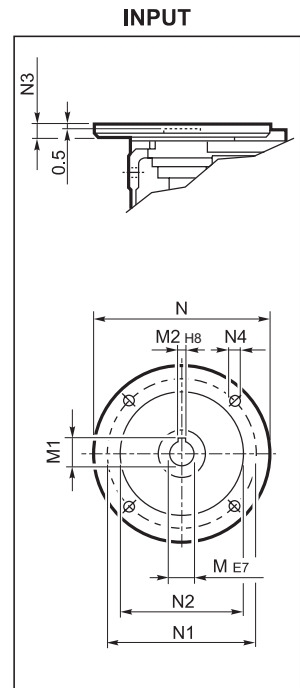
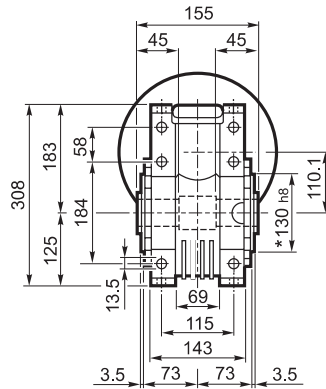
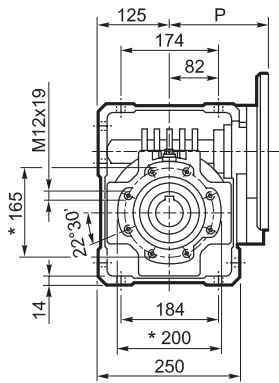

UF_

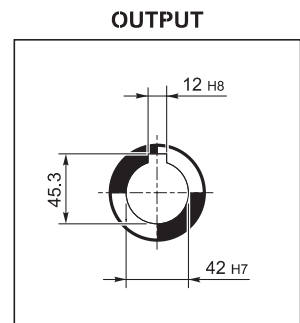
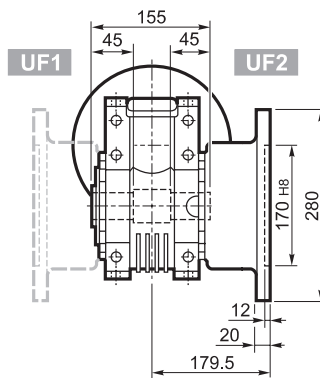
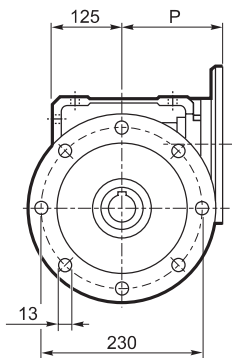

UFC_

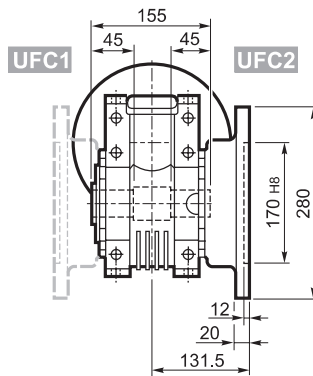
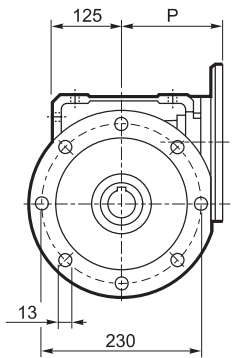

		M	M1	M2	N	N1	N2	N3	N4	P	
W 110	P80 B5	19	21.8	6	200	165	130	—	M10x12	143	28
W 110	P90 B5	24	27.3	8	200	165	130	—	M10x12	143	28
W 110	P100 B5	28	31.3	8	250	215	180	13	13	151	29
W 110	P112 B5	28	31.3	8	250	215	180	13	13	151	29
W 110	P132 B5	38	41.3	10	300	265	230	16	14	226	31
W 110	P80 B14	19	21.8	6	120	100	80	7.5	7	143	27.5
W 110	P90 B14	24	27.3	8	140	115	95	6.5	9	143	27.5
W 110	P100 B14	28	31.3	8	160	130	110	13	9	151	27
W 110	P112 B14	28	31.3	8	160	130	110	13	9	151	27

* Auf beiden seiten

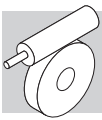

WR 110...P (IEC)

U

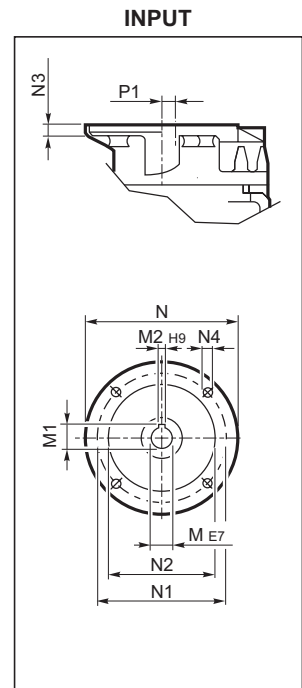
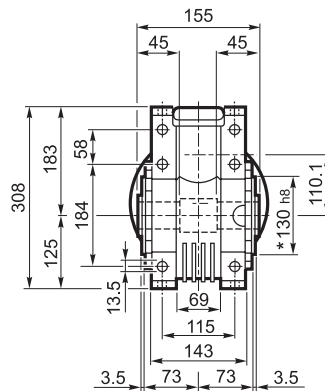
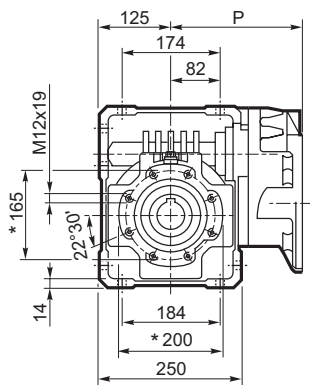

UF_

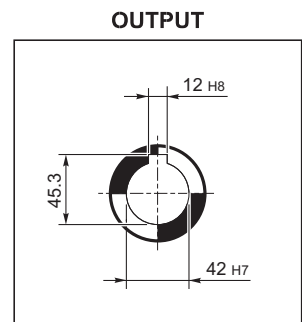
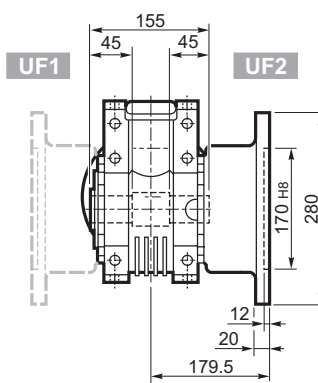
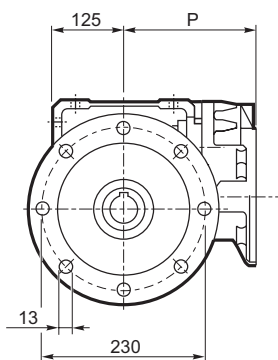

UFC_

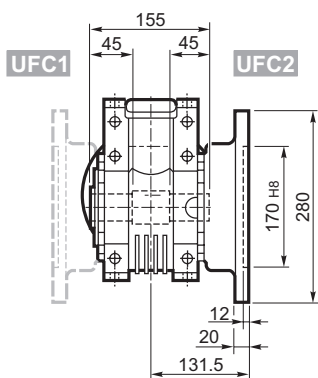
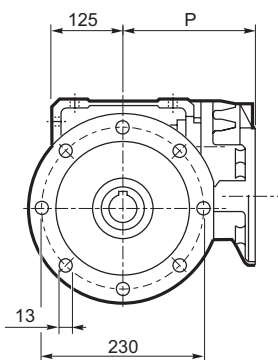

		M	M1	M2	N	N1	N2	N3	N4	P	P1	kg
		14	16.3	5	160	130	110	10	M8x14	185	58.6	30.5
WR 110	P71 B5	14	16.3	5	160	130	110	10	M8x14	185	58.6	30.5
WR 110	P80 B5	19	21.8	6	200	165	130	14	M10x15	204	21.1	31
WR 110	P90 B5	24	27.3	8	200	165	130	14	M10x15	204	21.1	31
WR 110	P100 B5	28	31.3	8	250	215	180	14	M12x13	213	21.1	32
WR 110	P112 B5	28	31.3	8	250	215	180	14	M12x13	213	21.1	32

* Auf beiden seiten

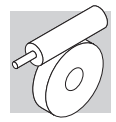

VF/W 49/110...P (IEC)

U

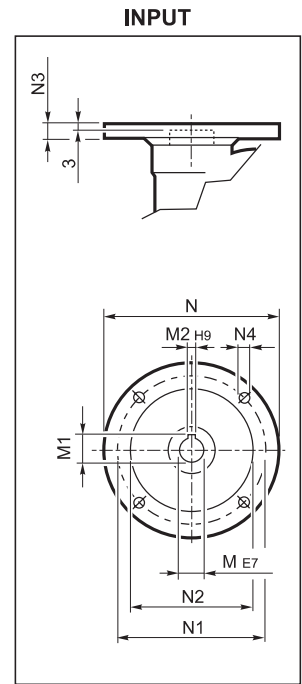
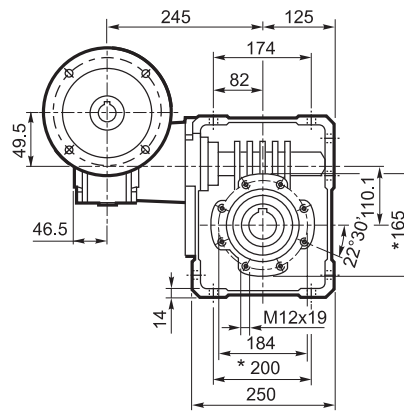
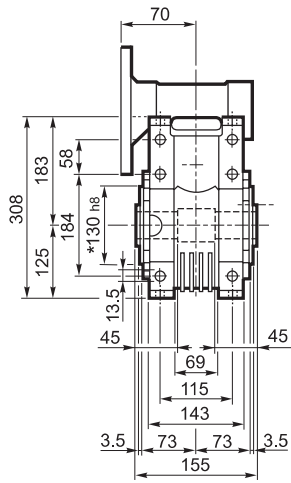

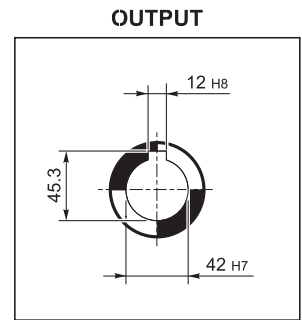
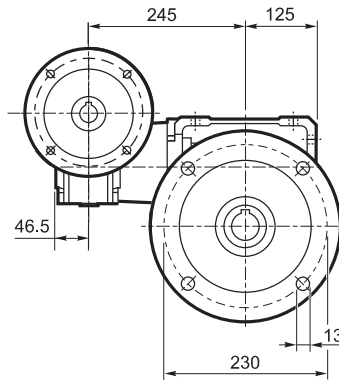
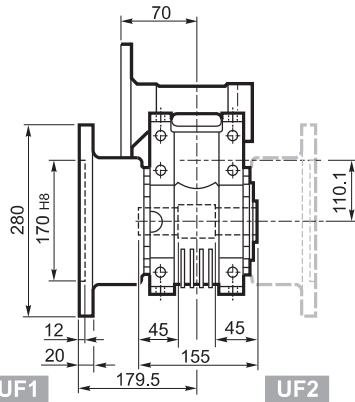

UF

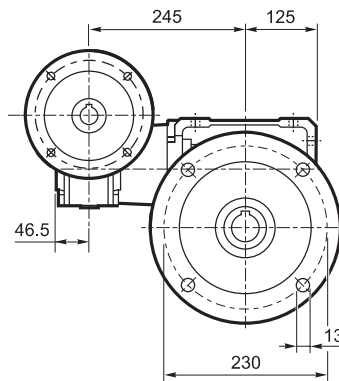
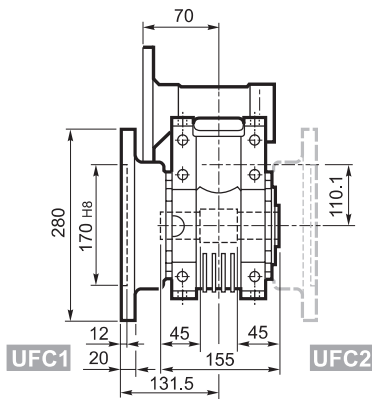

UFC



		M	M1	M2	N	N1	N2	N3	N4	
VF/W 49/110	P63 B5	11	12.8	4	140	115	95	10.5	9.5	33
VF/W 49/110	P71 B5	14	16.3	5	160	130	110	10.5	9.5	
VF/W 49/110	P80 B5	19	21.8	6	200	165	130	10	11.5	
VF/W 49/110	P63 B14	11	12.8	4	90	75	60	7	6	
VF/W 49/110	P71 B14	14	16.3	5	105	85	70	10.5	6.5	
VF/W 49/110	P80 B14	19	21.8	6	120	100	80	10	7	

* Auf beiden seiten

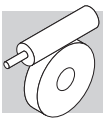

VF 130...P (IEC)

A

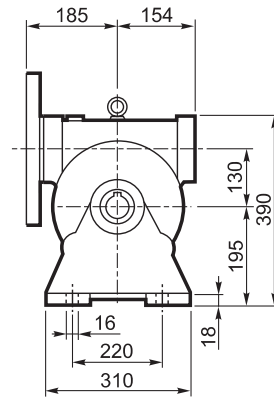
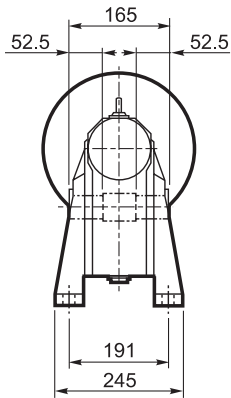

INPUT

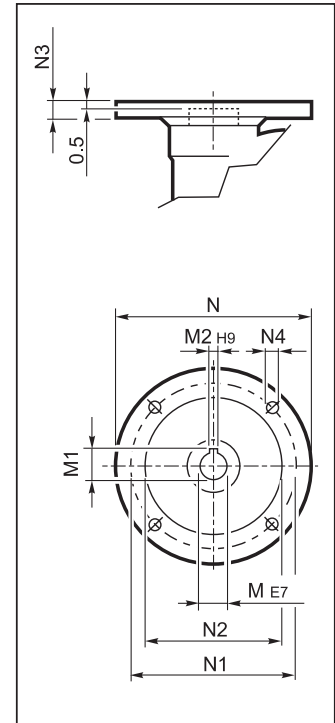

N

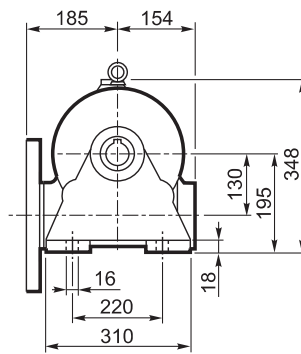
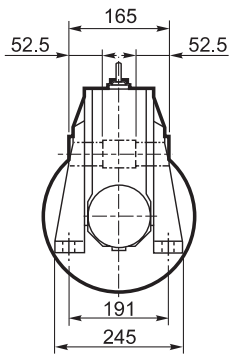

OUTPUT

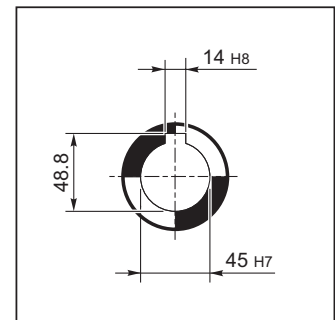

V

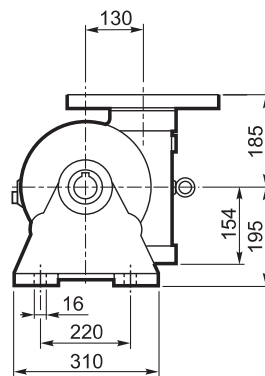
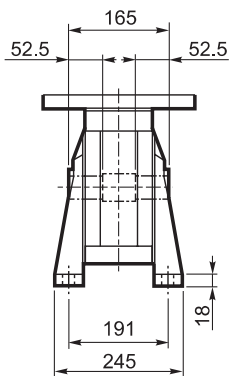

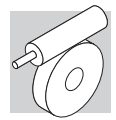

VF 130...P (IEC)

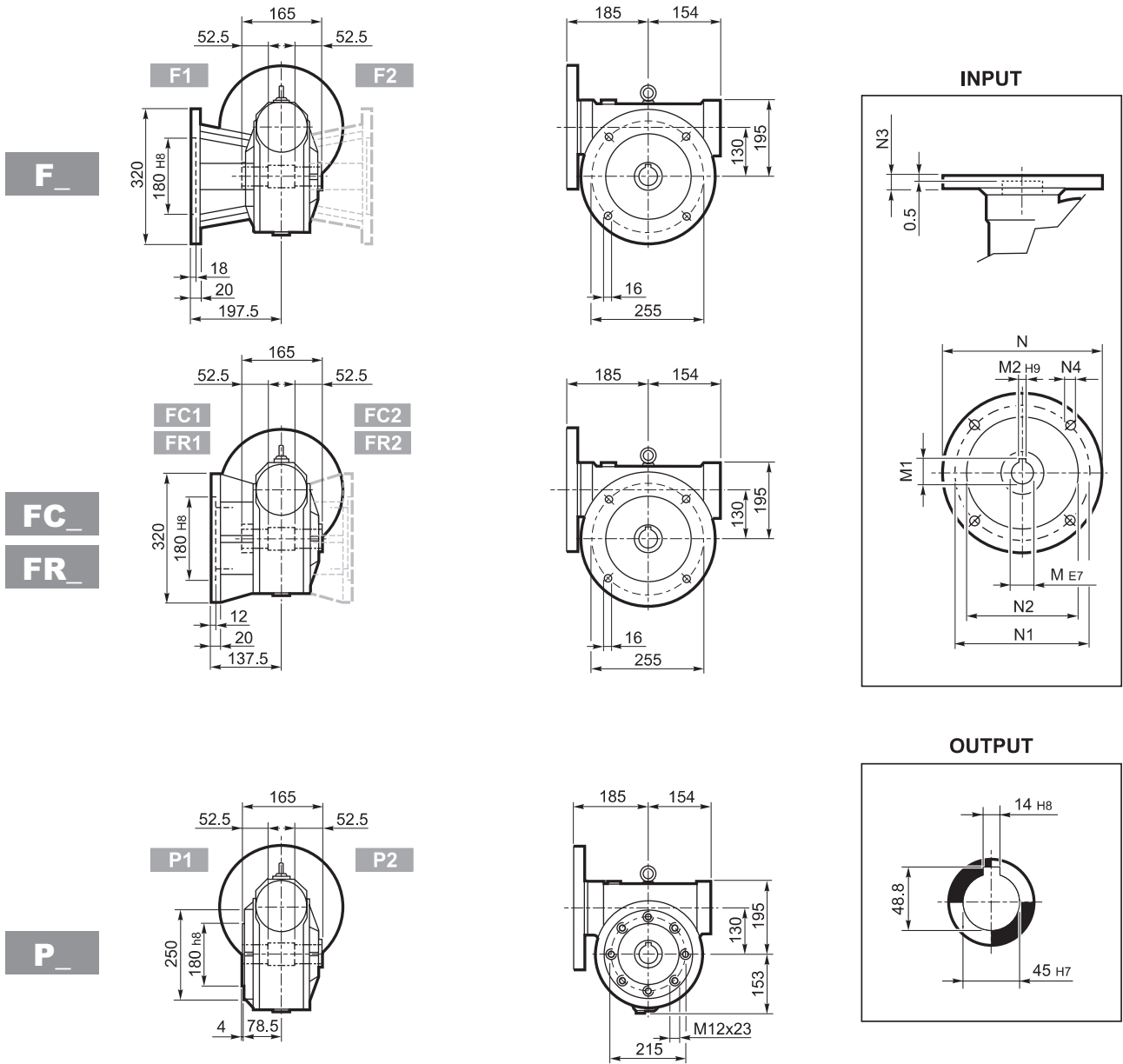

		M	M1	M2	N	N1	N2	N3	N4	
VF130	P90 B5	24	27.3	8	200	165	130	17	11	49
VF130	P100 B5	28	31.3	8	250	215	180	17	13	
VF130	P112 B5	28	31.3	8	250	215	180	17	13	
VF130	P132 B5	38	40.1#	10	300	265	230	17	13	

Verkleinertes Paßfeder

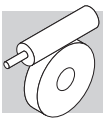

VFR 130...P (IEC)

A

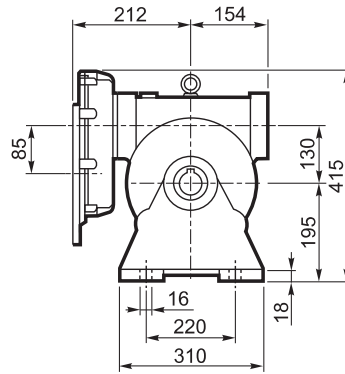
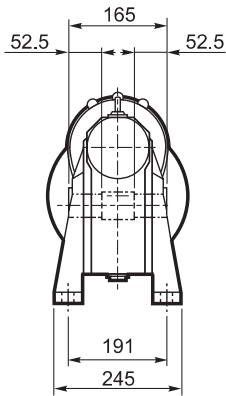

INPUT

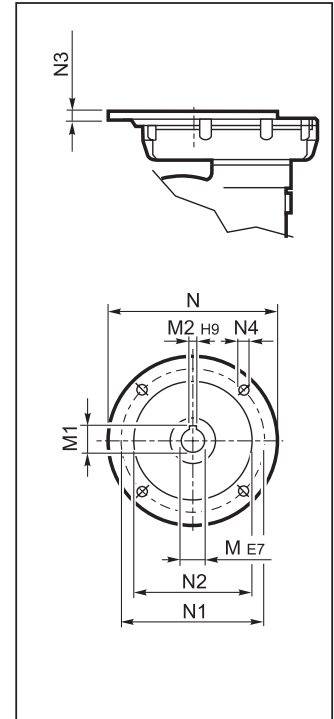

N

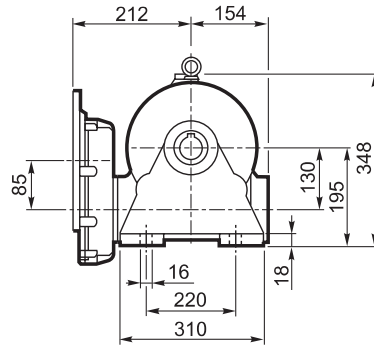
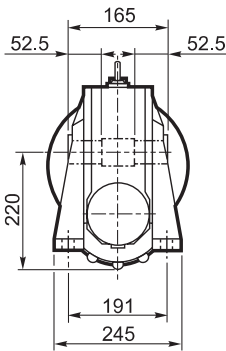

OUTPUT

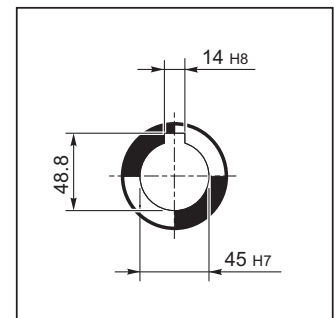



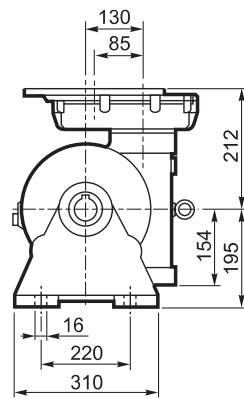
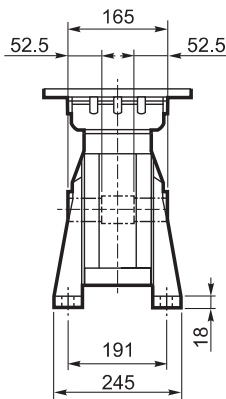

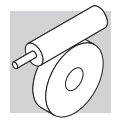
V



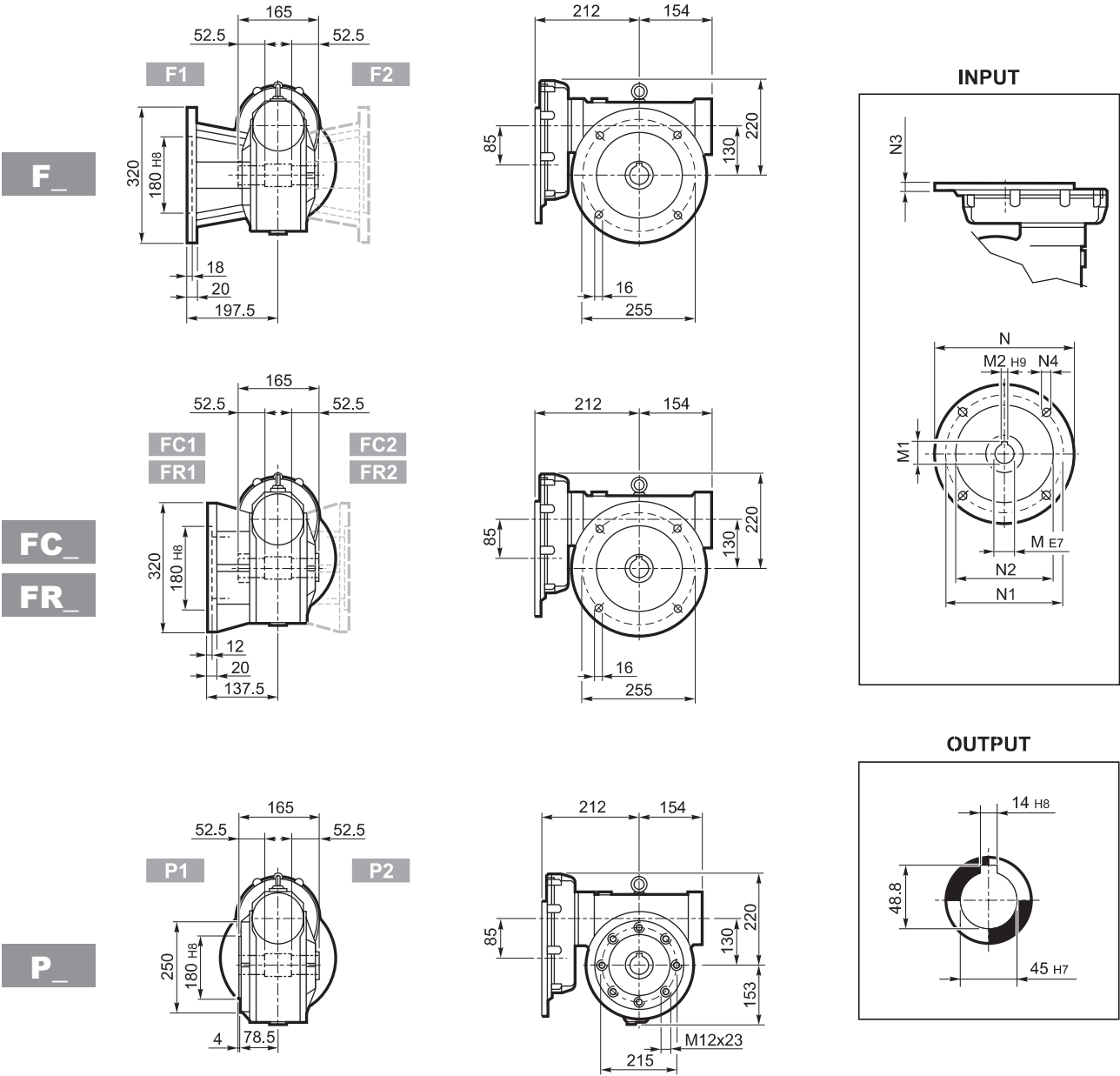

VFR 130...P (IEC)



		M	M1	M2	N	N1	N2	N3	N4	
VFR 130	P80 B5	19 K6	21.8	6	200	165	130	12	M10x25	57
VFR 130	P90 B5	24 K6	27.3	8	200	165	130	12	M10x25	
VRF 130	P100 B5	28 J6	29.1#	8	250	215	180	13	M12x35	
VRF 130	P112 B5	28 J6	29.1#	8	250	215	180	13	M12x35	

Verkleinertes Paßfeder

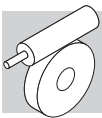

W/VF 63/130...M/ME/MX/MXN

A

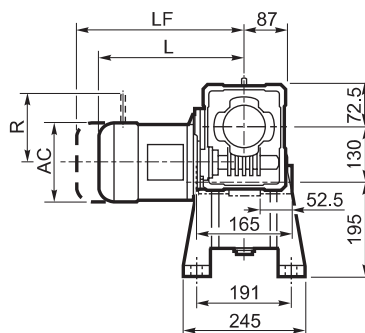
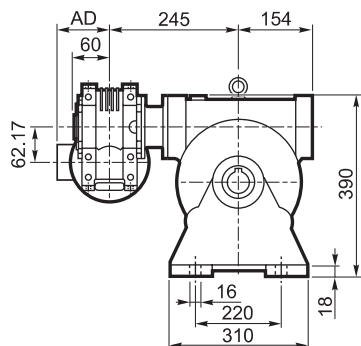

OUTPUT

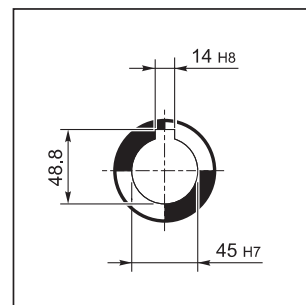

N

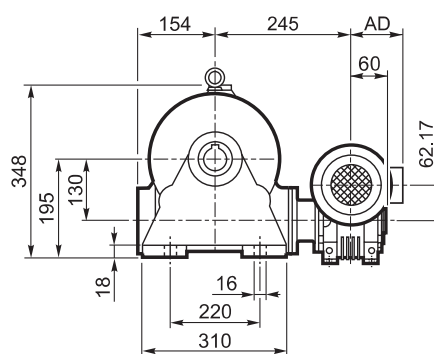
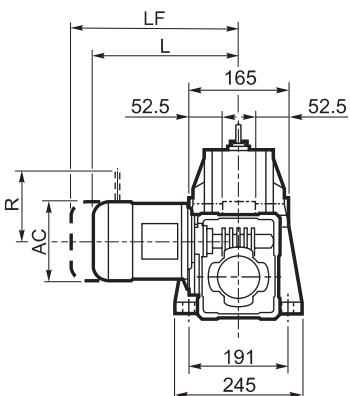

V

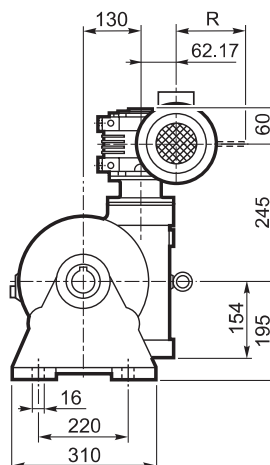
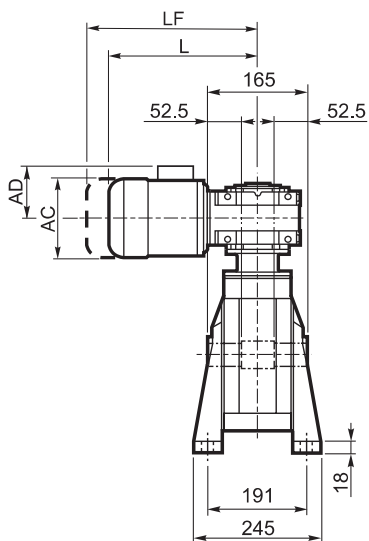

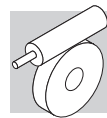

W/VF 63/130...M/ME/MX/MXN

F_
FC_
FR_

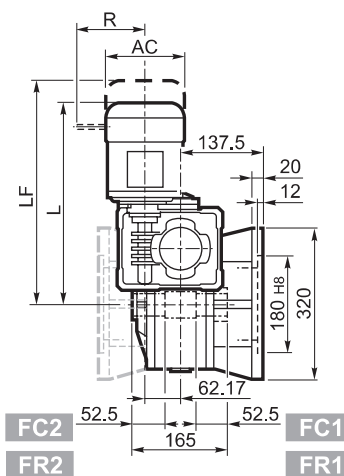
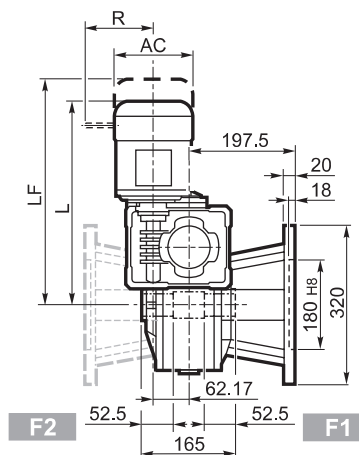
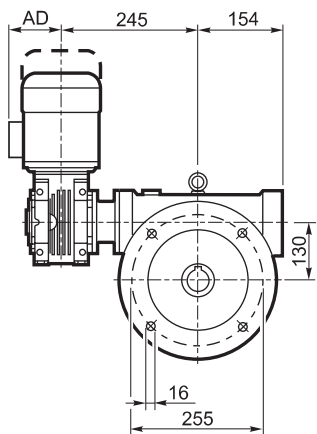

P_

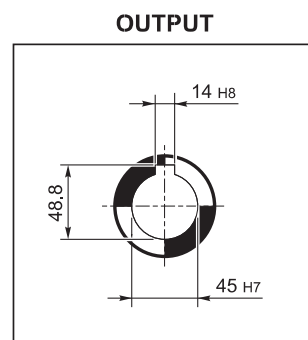
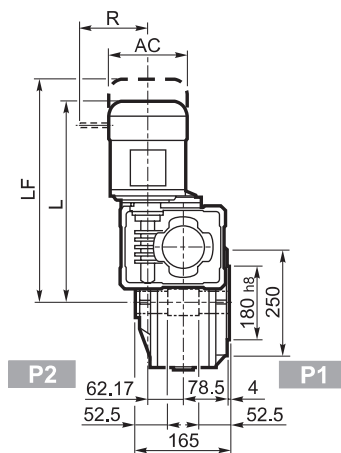
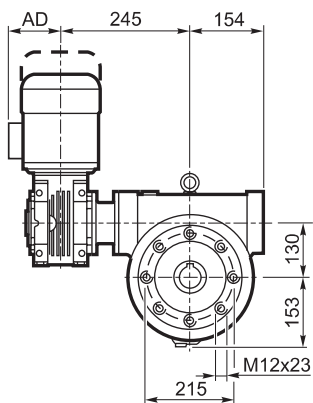

			M/ME/MX/MXN				M...FD M...FA		M...FD		M...FA	
			AC	L	AD	Kg	LF	Kg	R	AD	R	AD
W/VF 63/130	S1	M1	138	419	108	63	480	65	103	135	124	108
W/VF 63/130	S1	ME1	138	419	108	63	480	65	103	135	124	108
W/VF 63/130	S10	MXN10	138	448	137	65.4	507	67.7	103	138	121	138
W/VF 63/130	S2	ME2S	156	447	119	68	517	69.6	129	143	134	143
W/VF 63/130	S2	MX2S	156	491	119	73.1	563	76.9	129	143	134	143
W/VF 63/130	S20	MXN20	158	500.5	146	73.1	571.5	77	129	148	131	148

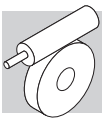

W/VF 63/130...P (IEC)

A

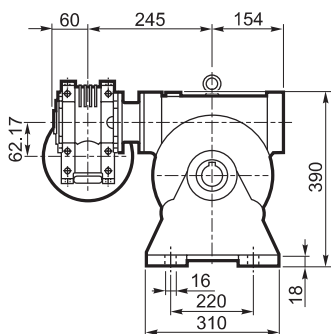

N

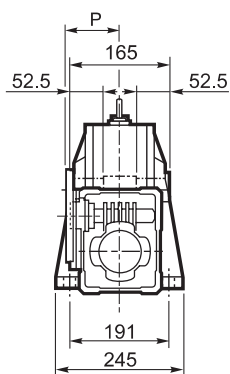

V

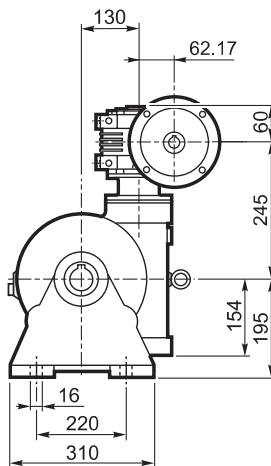
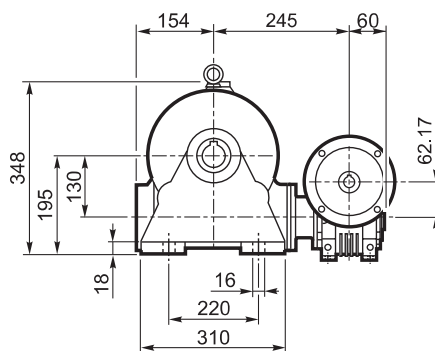
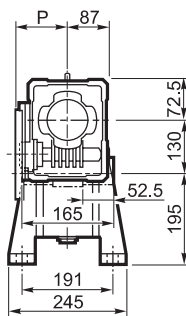
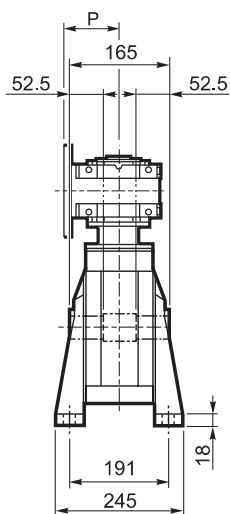

INPUT

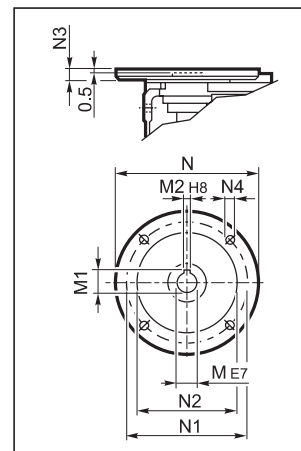

OUTPUT

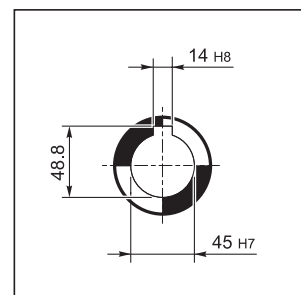

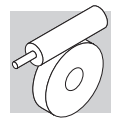

W/VF 63/130...P (IEC)

F_
FC_
FR_

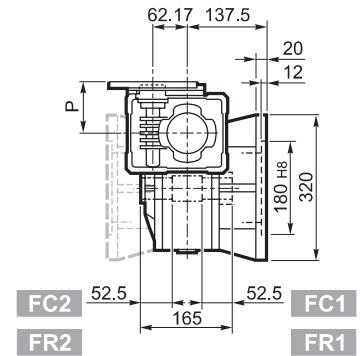
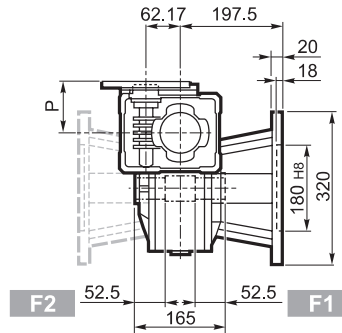
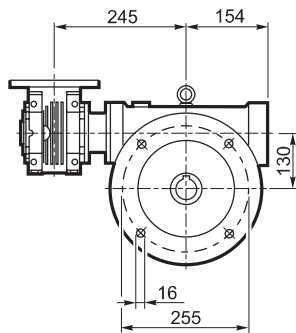

P_

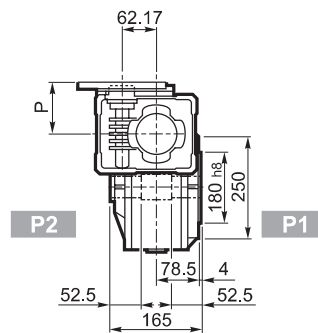
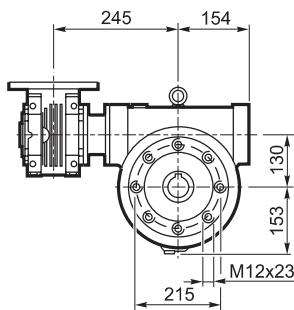

INPUT

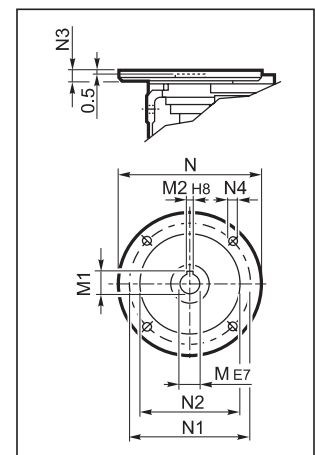

OUTPUT

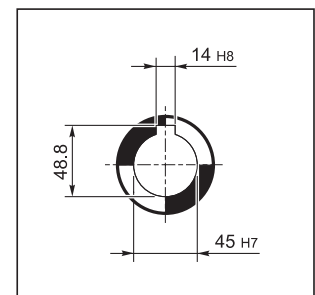

		M	M1	M2	N	N1	N2	N3	N4	P	
W/VF 63/130	P71 B5	14	16.3	5	160	130	110	11	9	95	57
W/VF 63/130	P80 B5	19	21.8	6	200	165	130	12	11.5	102	
W/VF 63/130	P90 B5	24	27.3	8	200	165	130	12	11.5	102	
W/VF 63/130	P71 B14	14	16.3	5	105	85	70	11	6.5	95	
W/VF 63/130	P80 B14	19	21.8	6	120	100	80	11	6.5	102	
W/VF 63/130	P90 B14	24	27.3	8	140	115	95	11	8.5	102	

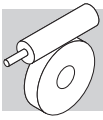

VF 150...P (IEC)

A

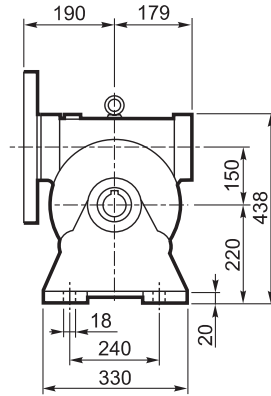
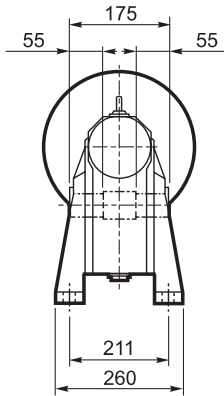

N

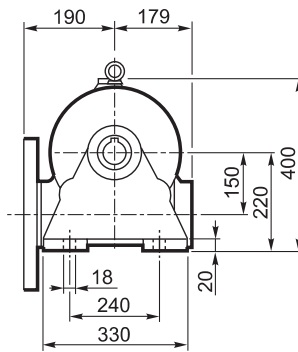
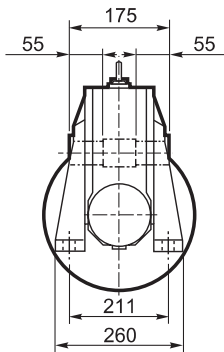

V

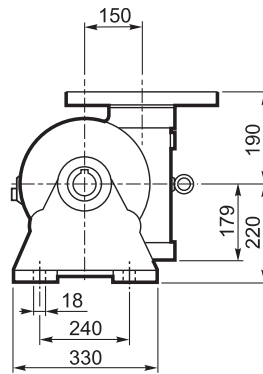
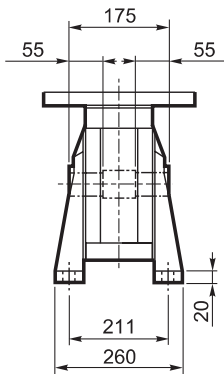

INPUT

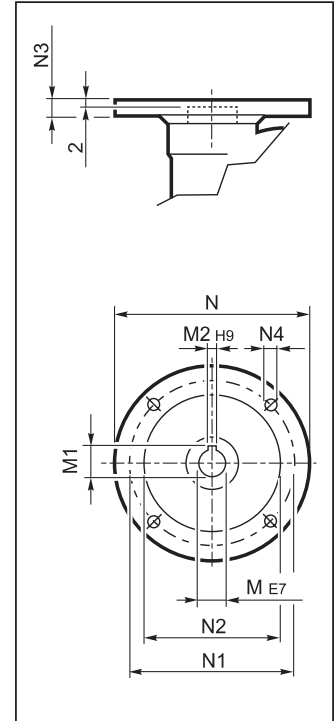

OUTPUT

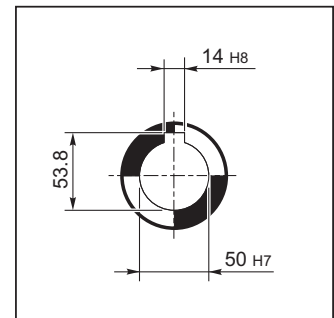

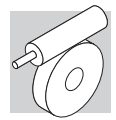

VF 150...P (IEC)

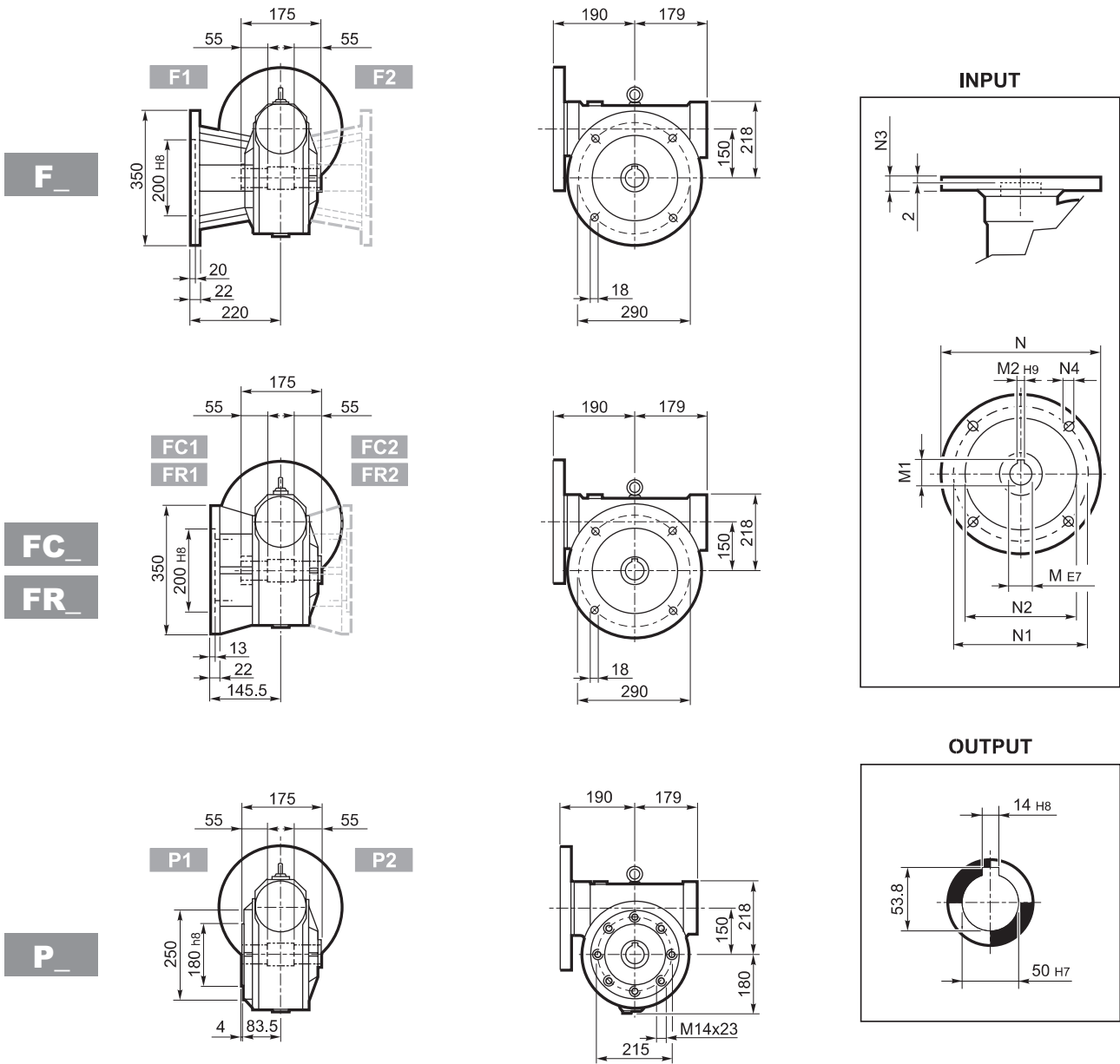

		M	M1	M2	N	N1	N2	N3	N4	
VF 150	P100 B5	28	31.3	8	250	215	180	11	13	60
VF 150	P112 B5	28	31.3	8	250	215	180	11	13	
VF 150	P132 B5	38	41.3	10	300	265	230	16	13	
VF 150	P160 B5	42	44.6#	12	350	300	250	18	18	

Verkleinertes Paßfeder

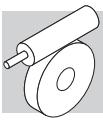

VFR 150...P (IEC)

A

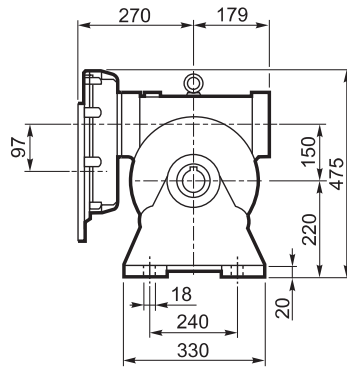
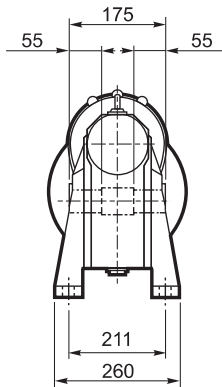

INPUT

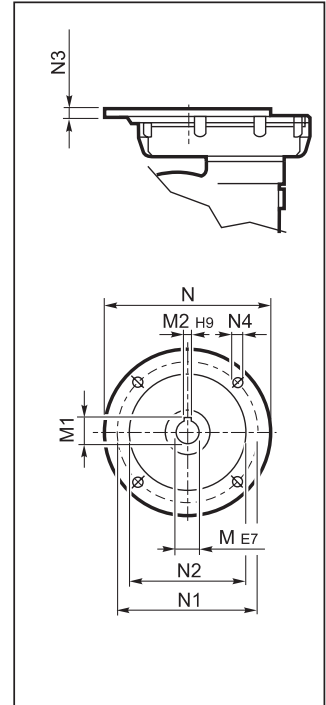

N

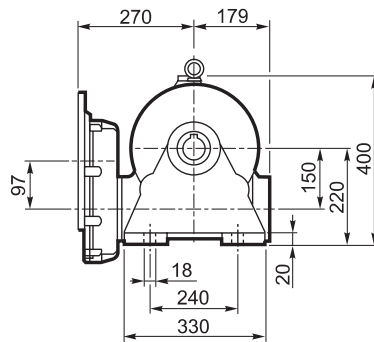
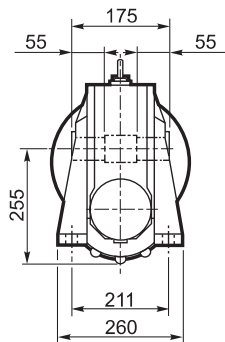

OUTPUT

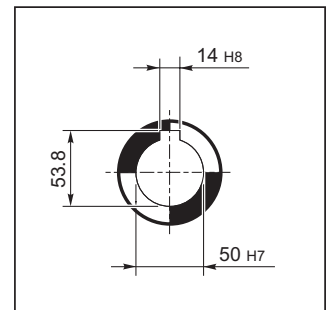

V

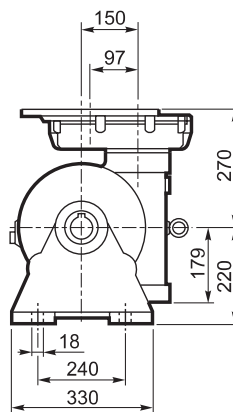
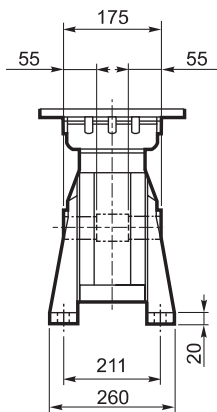

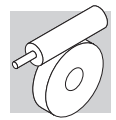

VFR 150...P (IEC)

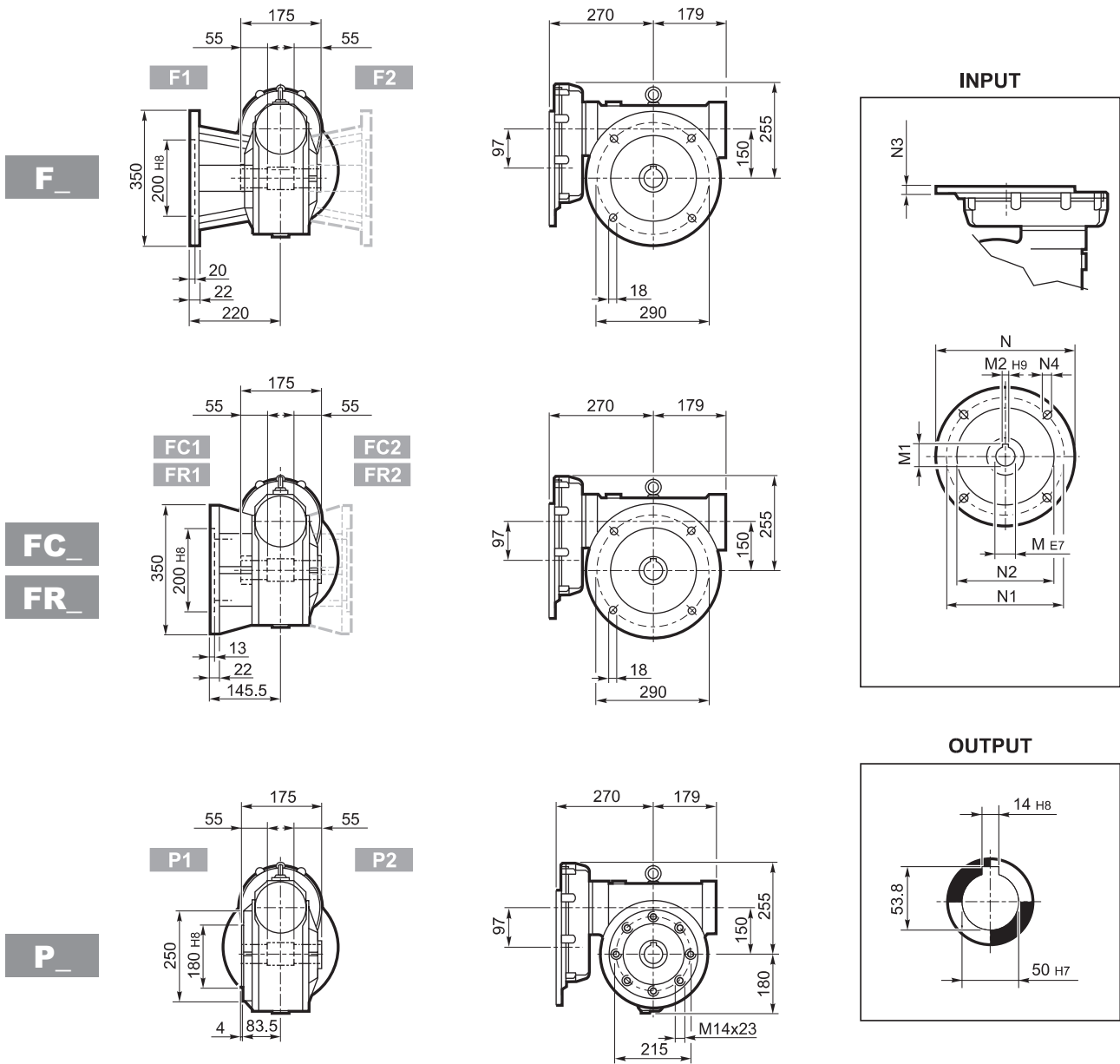

		M	M1	M2	N	N1	N2	N3	N4	
VFR 150	P90 B5	24 K6	27.3	8	200	165	130	13	M10x25	71
VRF 150	P100 B5	28 K6	31.3	8	250	215	180	13	M12x35	
VRF 150	P112 B5	28 J6	31.3	8	250	215	180	13	M12x35	
VFR 150	P132 B5	38 J6	39.6#	10	300	265	230	13	M12x35	

Verkleinertes Paßfeder

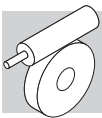

W/VF 86/150...M/ME/MX/MXN

A

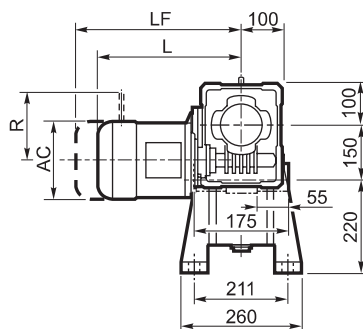
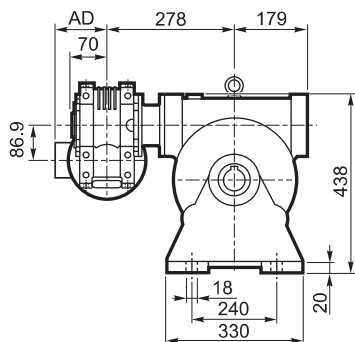

OUTPUT

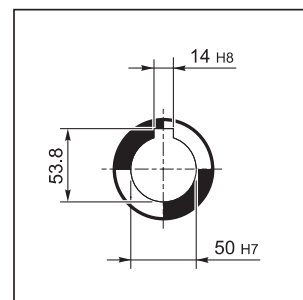

N

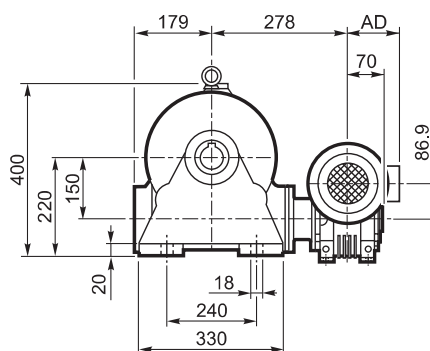
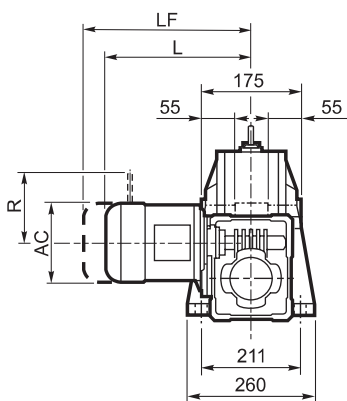

V

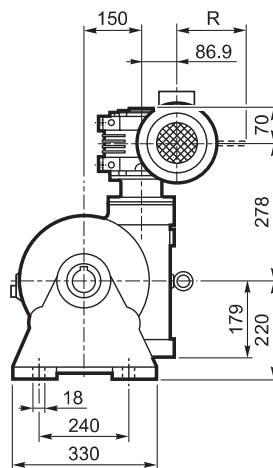
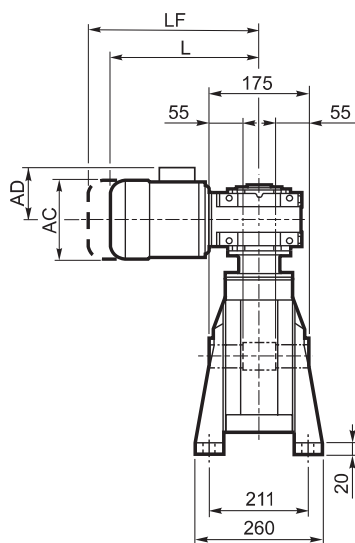

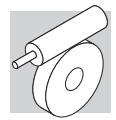

W/VF 86/150...M/ME/MX/MXN

F_
FC_
FR_

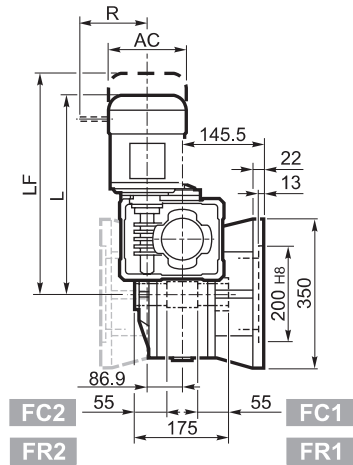
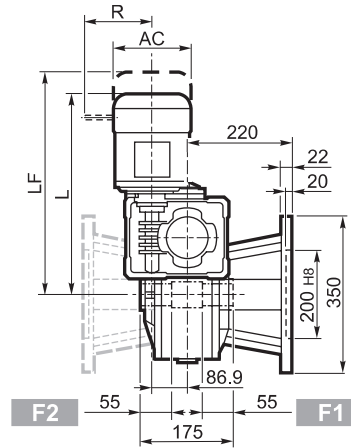
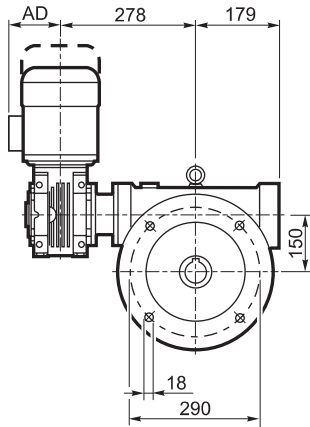

P_

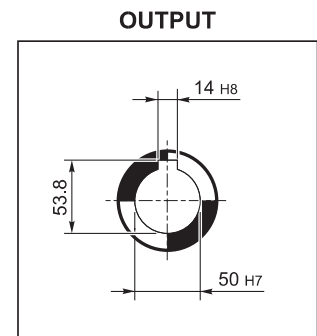
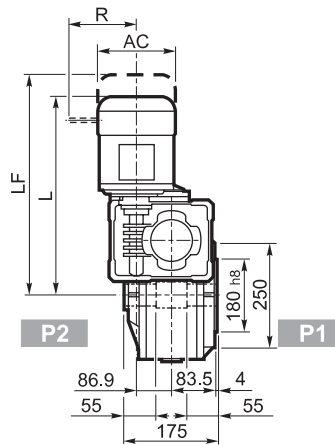
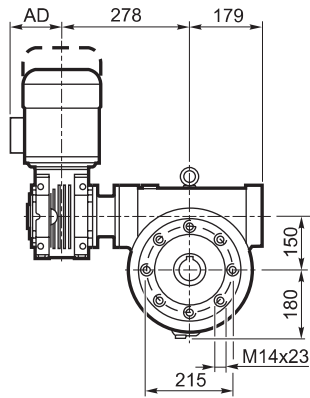

			M/ME/MX/MXN				M...FD M...FA		M...FD		M...FA	
			AC	L	AD	Kg	LF	Kg	R	AD	R	AD
W/VF 86/150	S1	M1	138	474	108	82	385	84	103	135	124	108
W/VF 86/150	S1	ME1	138	474	108	82	534	84	103	135	124	135
W/VF 86/150	S10	MXN10	138	503	137	84.4	562	86.8	103	138	121	138
W/VF 86/150	S2	ME2S	156	499	119	86	569	87.6	129	143	134	143
W/VF 86/150	S2	MX2S	156	543	119	91.1	615	94.9	129	143	134	143
W/VF 86/150	S20	MXN20	158	596.5	146	91.1	667.5	95	129	148	131	148
W/VF 86/150	S3	ME3S	195	542	142	92.5	638	98.5	160	155	160	155
W/VF 86/150	S3	MX3S	195	574	142	95.5	664	102.5	160	155	160	155
W/VF 86/150	S3	ME3L	195	574	142	98	665	104	160	155	160	155
W/VF 86/150	S3	MX3L	195	618	142	104	710	111	160	155	160	155

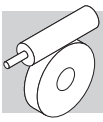

W/VF 86/150...P (IEC)

A

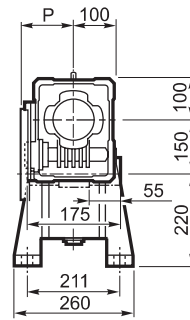
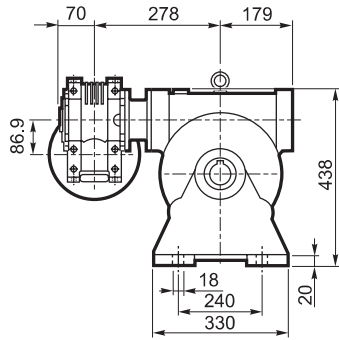

INPUT

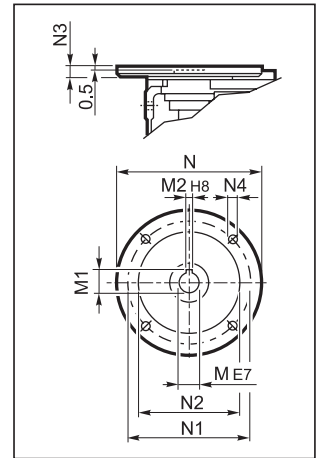

N

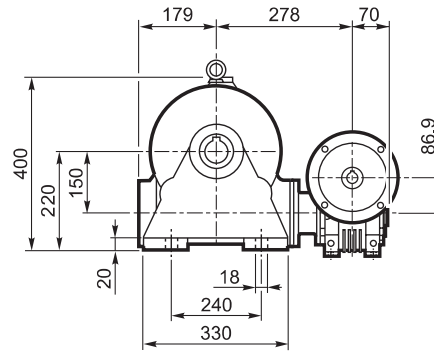
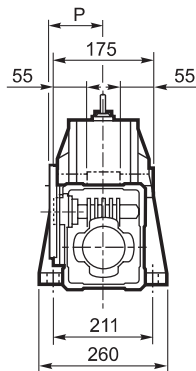

OUTPUT

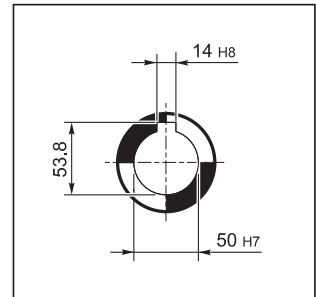

V

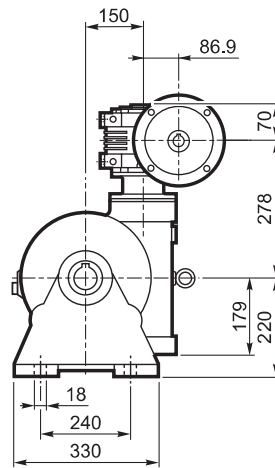
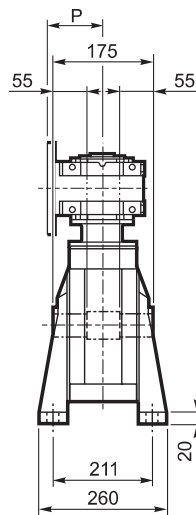

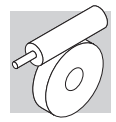

W/VF 86/150...P (IEC)

F
FC
FR

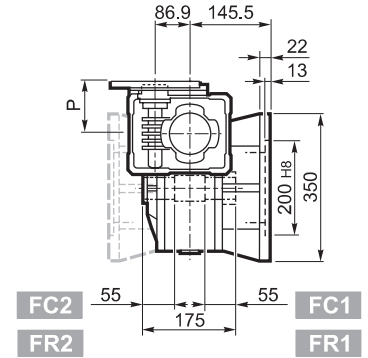
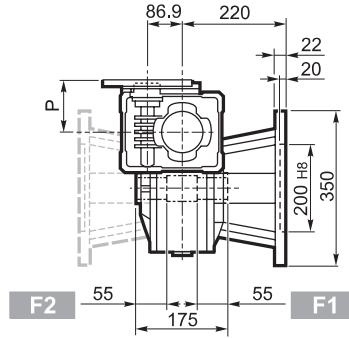
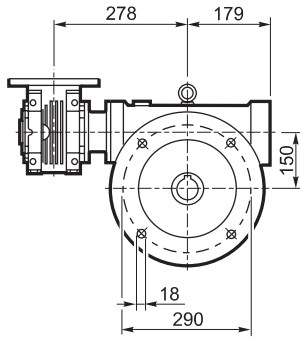

P

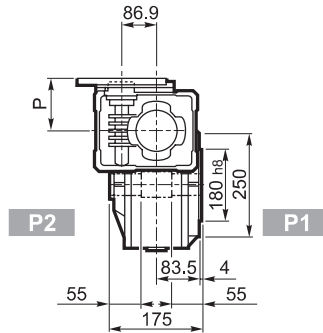
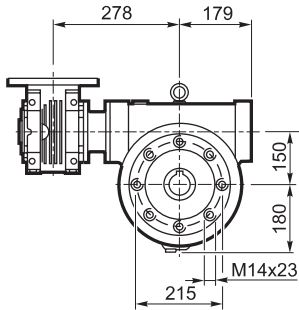

INPUT

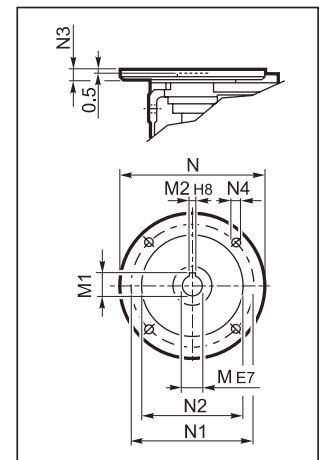

OUTPUT

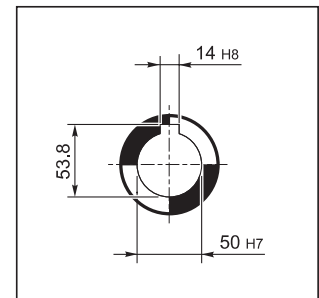

		M	M1	M2	N	N1	N2	N3	N4	P	
W/VF 86/150	P71 B5	14	16.3	5	160	130	110	11	9	128	75
W/VF 86/150	P80 B5	19	21.8	6	200	165	130	12	11.5	128	
W/VF 86/150	P90 B5	24	27.3	8	200	165	130	12	11.5	128	
W/VF 86/150	P100 B5	28	31.3	8	250	215	180	13	12.5	136	
W/VF 86/150	P112 B5	28	31.3	8	250	215	180	13	12.5	136	
W/VF 86/150	P80 B14	19	21.8	6	120	100	80	7.5	6.5	128	
W/VF 86/150	P90 B14	24	27.3	8	140	115	95	7.5	8.5	128	
W/VF 86/150	P100 B14	28	31.3	8	160	130	110	10	8.5	136	
W/VF 86/150	P112 B14	28	31.3	8	160	130	110	10	8.5	136	

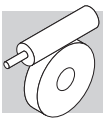

VF 185...P (IEC)

A

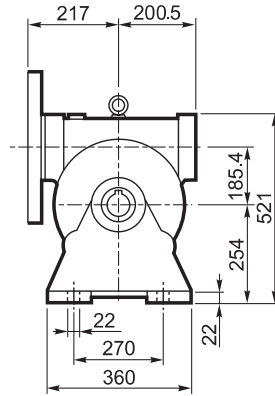
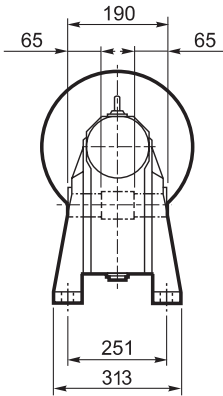

N

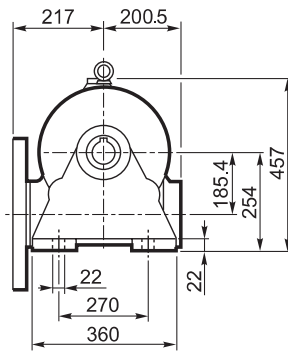
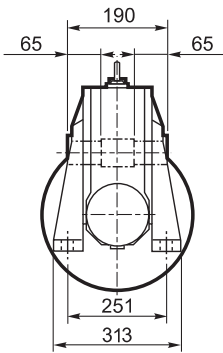

V

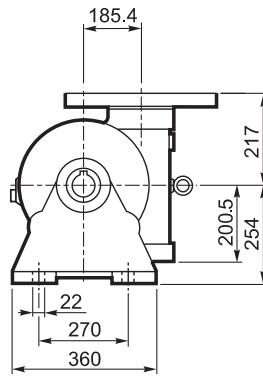
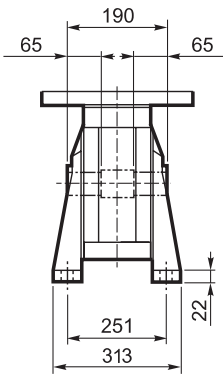

INPUT

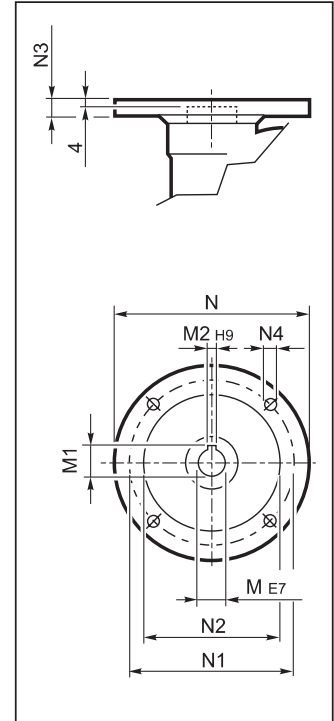

OUTPUT

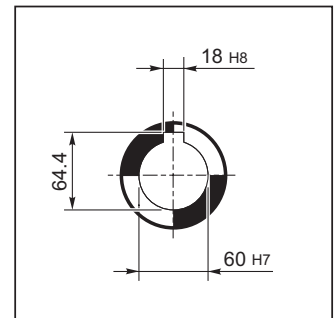

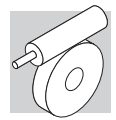

VF 185...P (IEC)

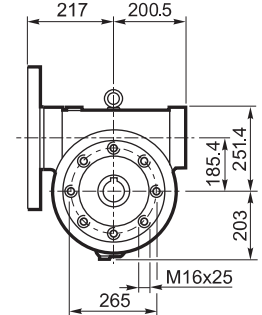
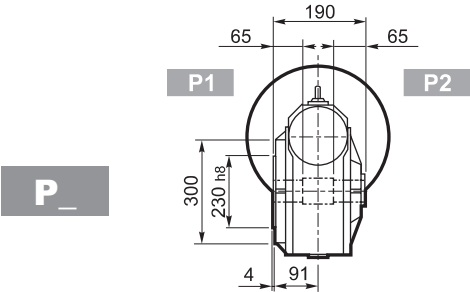
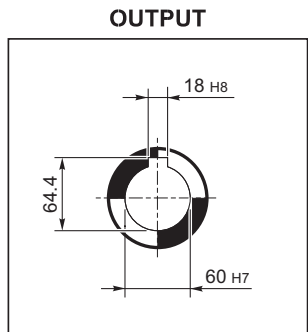
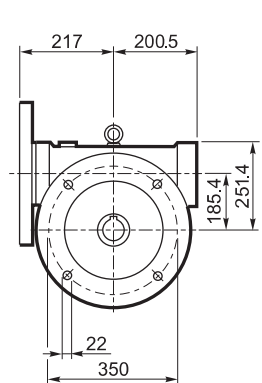
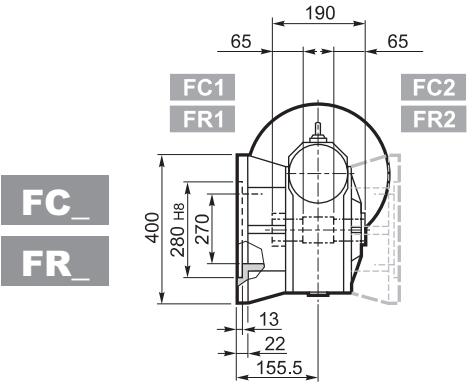
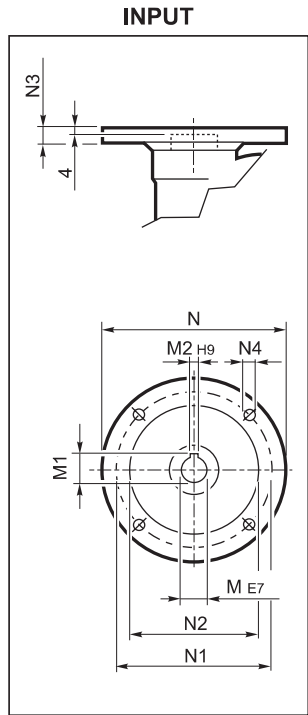
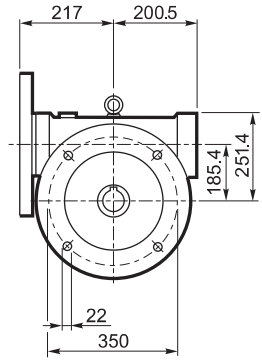
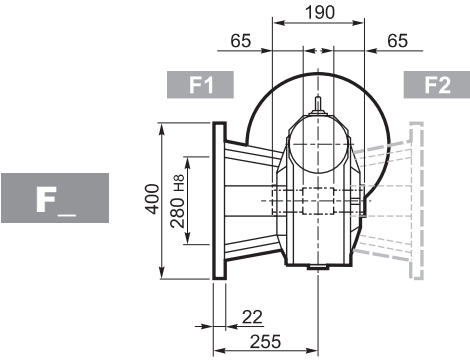

		M	M1	M2	N	N1	N2	N3	N4	
VF 185	P100 B5	28	31.3	8	250	215	180	16	13	94
VF 185	P112 B5	28	31.3	8	250	215	180	16	13	
VF 185	P132 B5	38	41.3	10	300	265	230	16	13	
VF 185	P160 B5	42	45.3	12	350	300	250	18	18	
VF 185	P180 B5	48	51.2#	14	350	300	250	18	18	

Verkleinertes Paßfeder

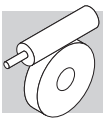

VFR 185...P (IEC)

A

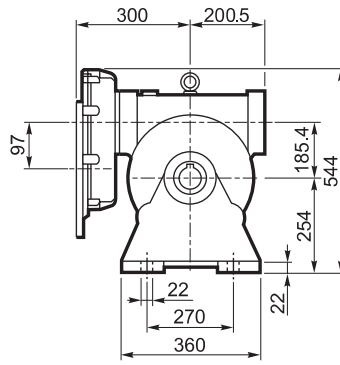
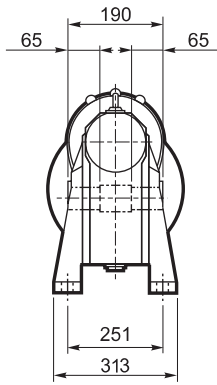

INPUT

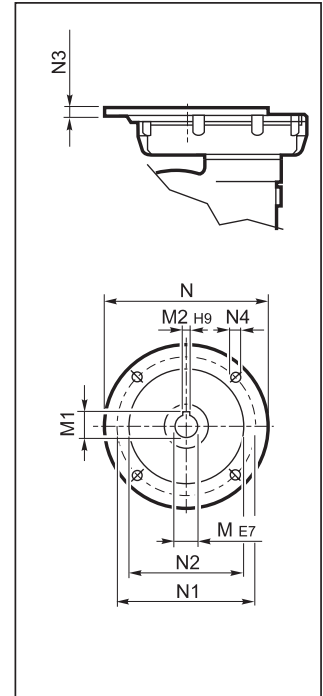

N

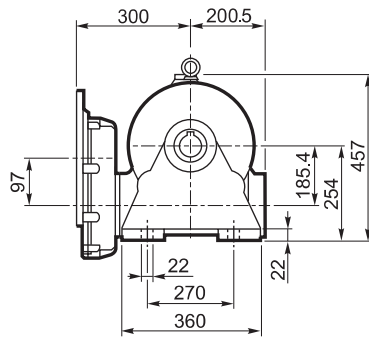
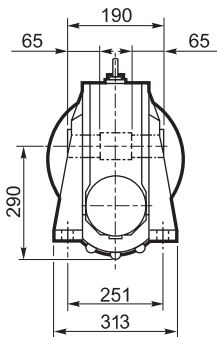

OUTPUT

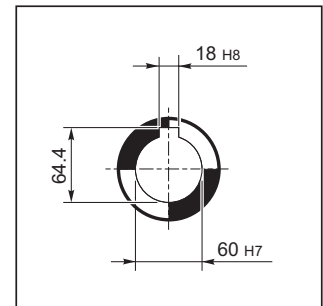



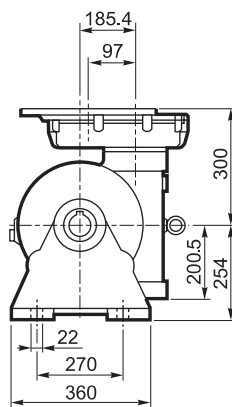
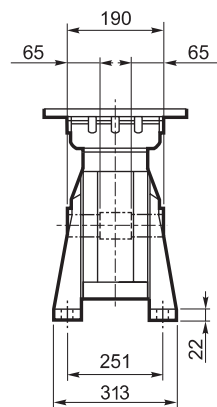

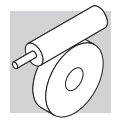
V



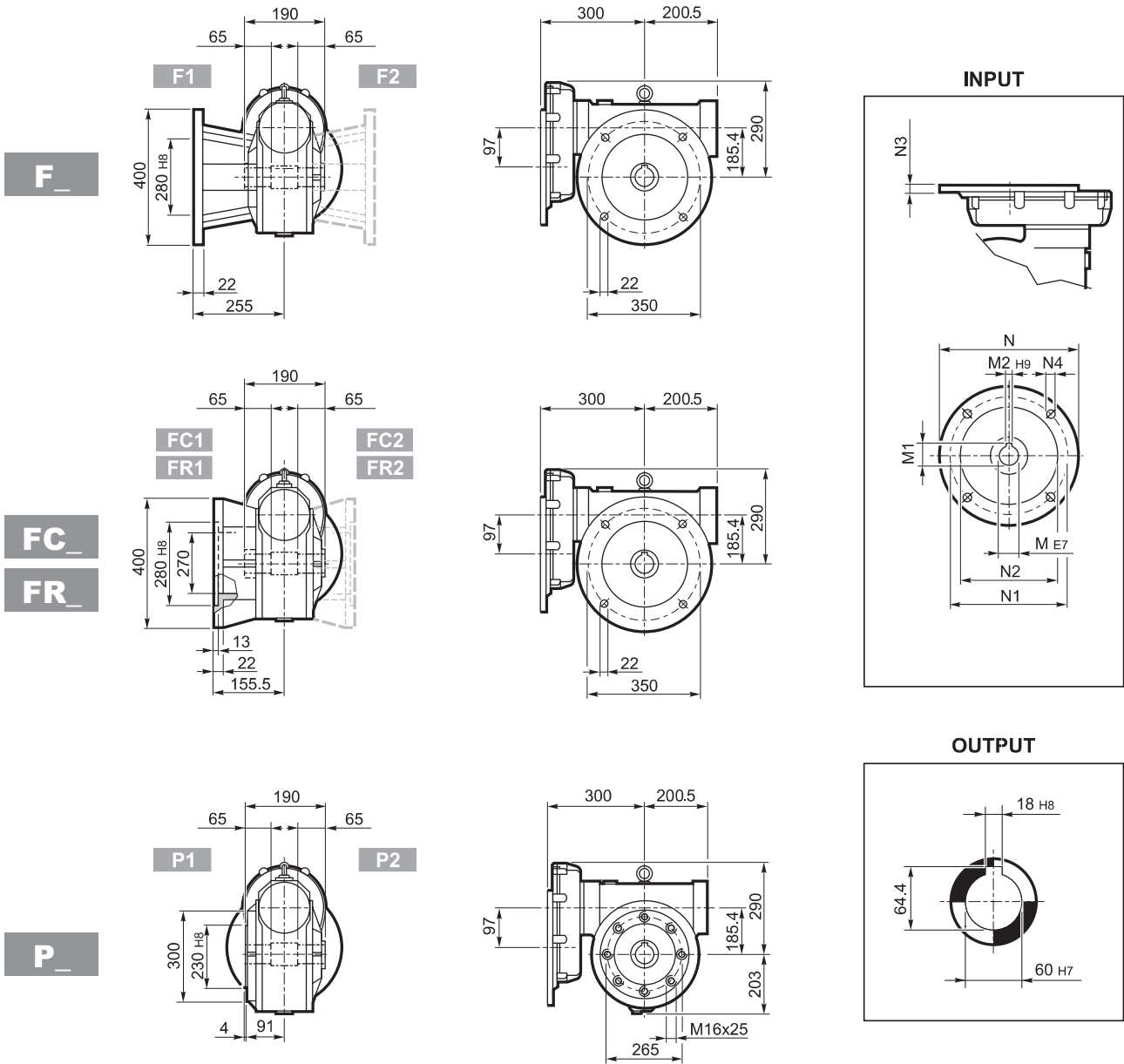

VFR 185...P (IEC)



		M	M1	M2	N	N1	N2	N3	N4	
VFR 185	P90 B5	24 K6	27.3	8	200	165	130	13	M10x25	110
VRF 185	P100 B5	28 K6	31.3	8	250	215	180	13	M12x35	
VRF 185	P112 B5	28 K6	31.3	8	250	215	180	13	M12x35	
VFR 185	P132 B5	38 J6	39.6#	10	300	265	230	13	M12x35	

Verkleinertes Paßfeder

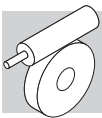

W/VF 86/185...M/ME/MX/MXN

A

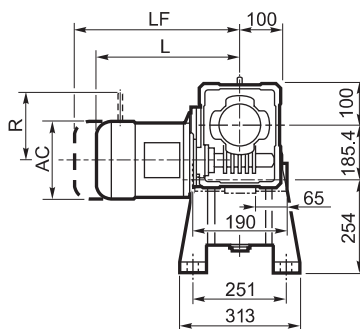
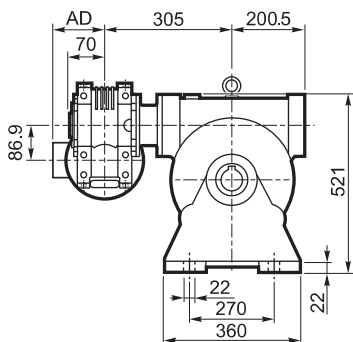

OUTPUT

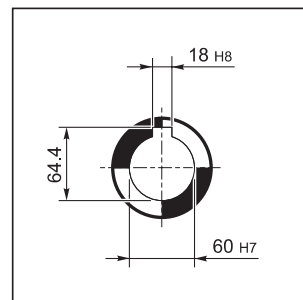

N

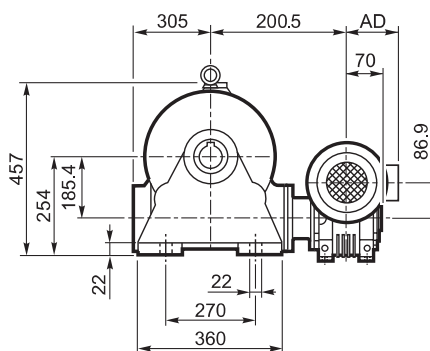
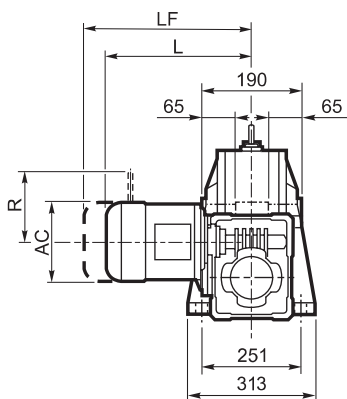

V

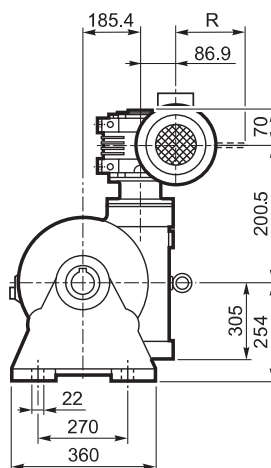
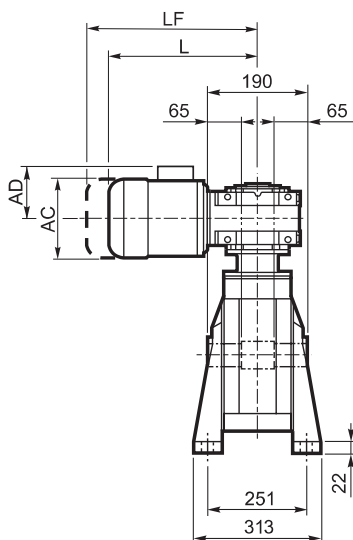

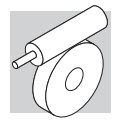

W/VF 86/185...M/ME/MX/MXN

F_
FC_
FR_

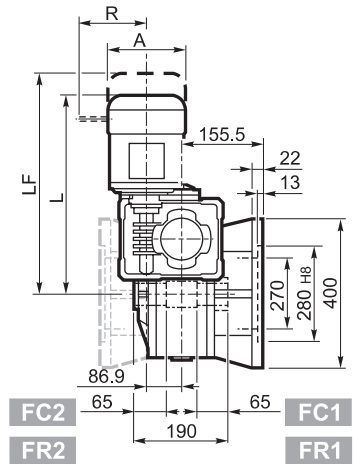
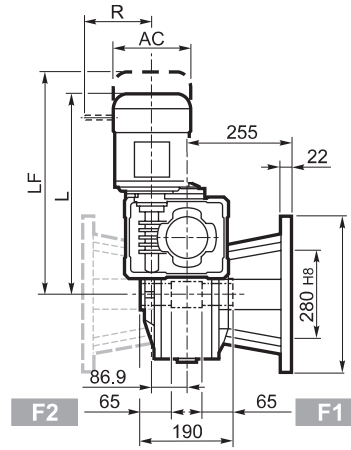
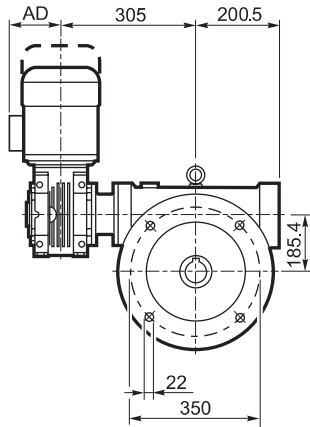

P_

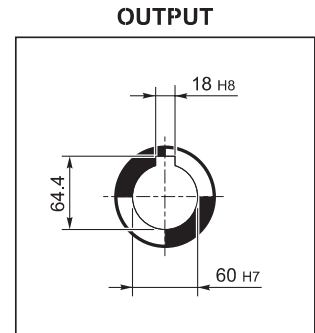
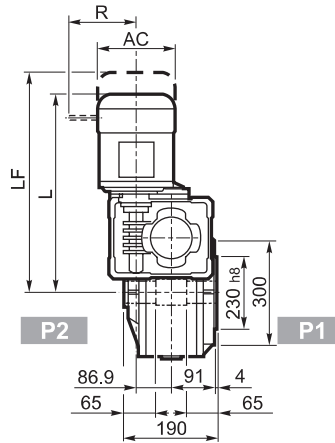
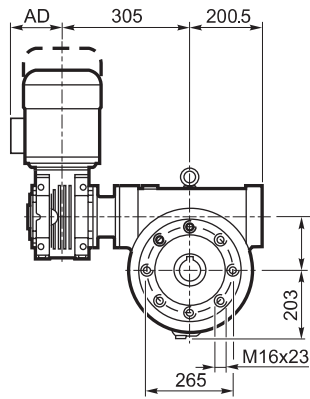

			M/ME/MX/MXN				M...FD M...FA		M...FD		M...FA	
			AC	L	AD	Kg	LF	Kg	R	AD	R	AD
W/VF 86/185	S1	M1	138	509	108	116	570	118	103	135	124	108
W/VF 86/185	S1	ME1	138	509	108	116	599	118	103	135	124	135
W/VF 86/185	S10	MXN10	138	538	137	118.4	597	120.8	103	138	121	138
W/VF 86/185	S2	ME2S	156	534	119	120	604	121.6	129	143	134	143
W/VF 86/185	S2	MX2S	156	578	119	125.1	650	128.9	129	143	134	143
W/VF 86/185	S20	MXN20	158	631.5	146	125.1	702.5	127.3	129	148	131	148
W/VF 86/185	S3	ME3S	195	577	142	126.5	673	132.5	160	155	160	155
W/VF 86/185	S3	MX3S	195	609	142	129.5	699	136.5	160	155	160	155
W/VF 86/185	S3	ME3L	195	609	142	132	700	138	160	155	160	155
W/VF 86/185	S3	MX3L	195	653	142	138	745	145	160	155	160	155

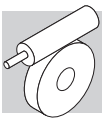

W/VF 86/185...P (IEC)

A

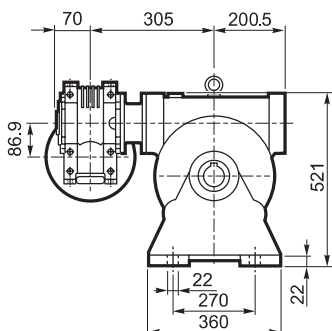

N

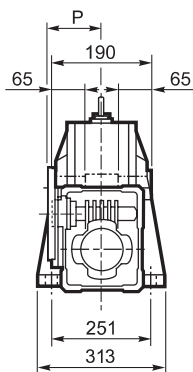

V

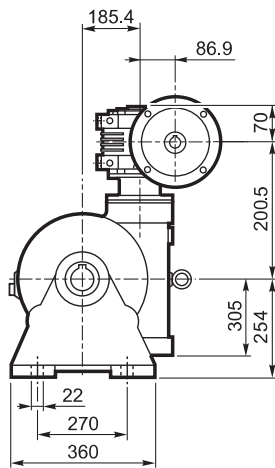
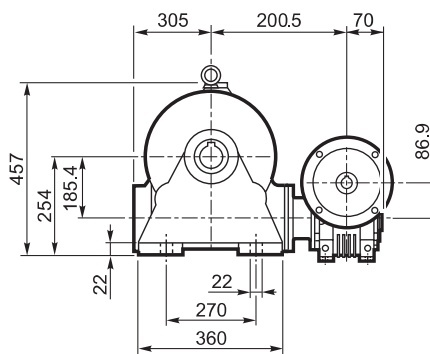
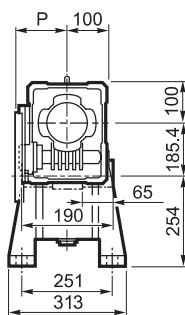
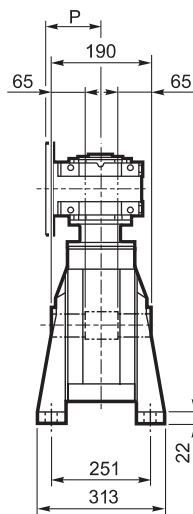

INPUT

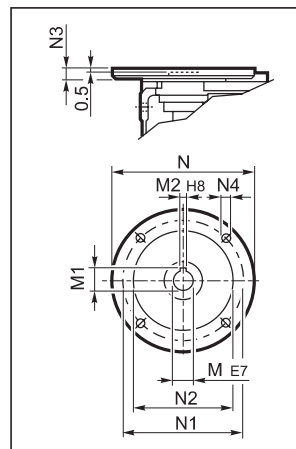

OUTPUT

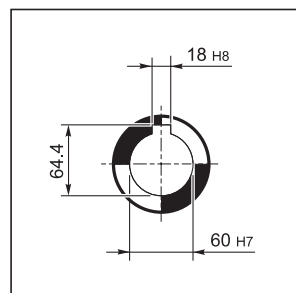

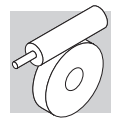

W/VF 86/185...P (IEC)

F_
FC_
FR_

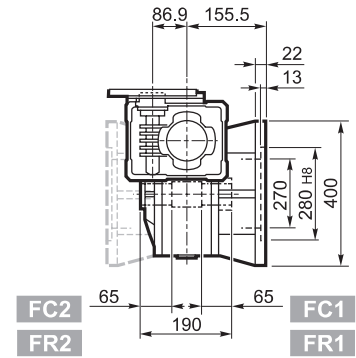
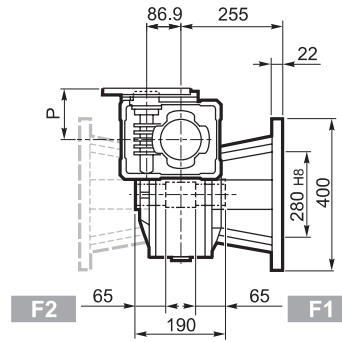
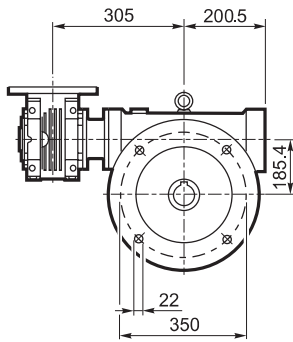

P_

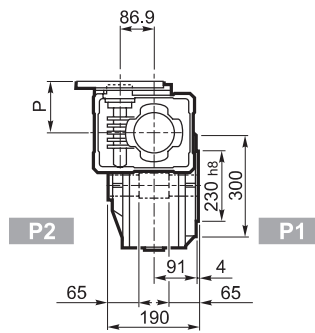
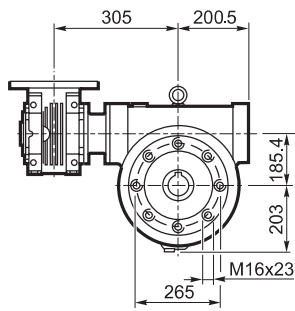

INPUT

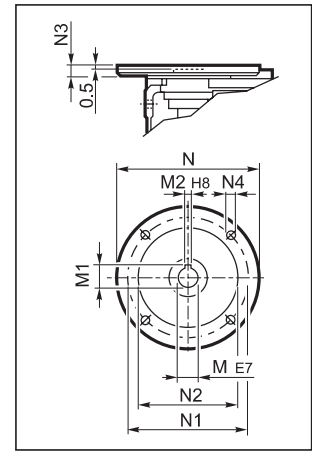

OUTPUT

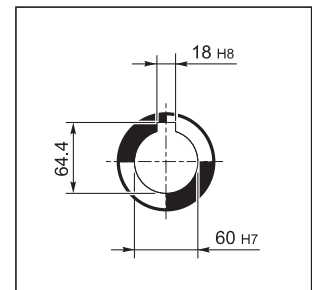

		M	M1	M2	N	N1	N2	N3	N4	P	
W/VF 86/185	P71 B5	14	16.3	5	160	130	110	11	9	128	109
W/VF 86/185	P80 B5	19	21.8	6	200	165	130	12	11.5	128	
W/VF 86/185	P90 B5	24	27.3	8	200	165	130	12	11.5	128	
W/VF 86/185	P100 B5	28	31.3	8	250	215	180	13	12.5	136	
W/VF 86/185	P112 B5	28	31.3	8	250	215	180	13	12.5	136	
W/VF 86/185	P80 B14	19	21.8	6	120	100	80	7.5	6.5	128	
W/VF 86/185	P90 B14	24	27.3	8	140	115	95	7.5	8.5	128	
W/VF 86/185	P100 B14	28	31.3	8	160	130	110	10	8.5	136	
W/VF 86/185	P112 B14	28	31.3	8	160	130	110	10	8.5	136	

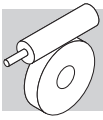

VF 210...P (IEC)

A

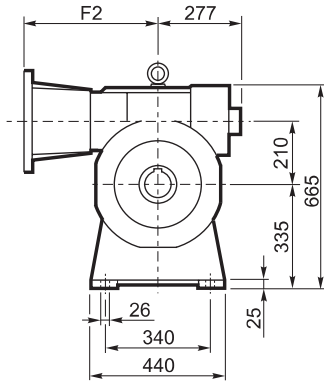
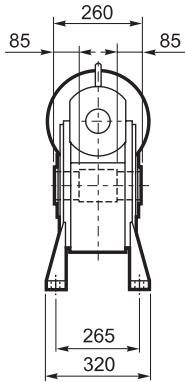

N

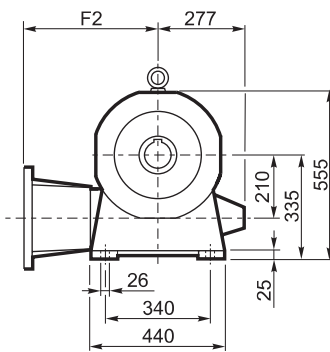
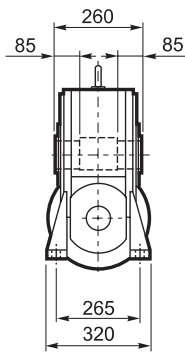

INPUT

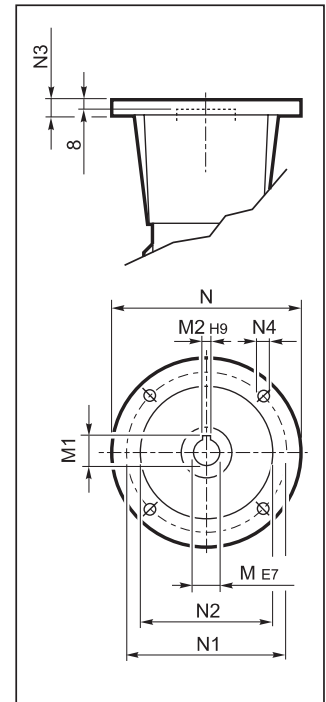

OUTPUT

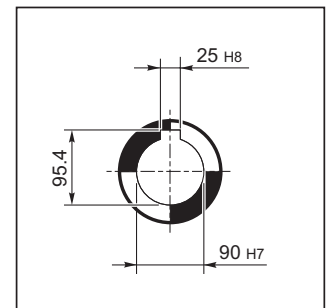

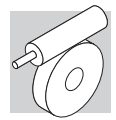

VF 210...P (IEC)

V

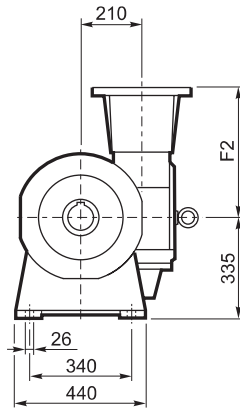
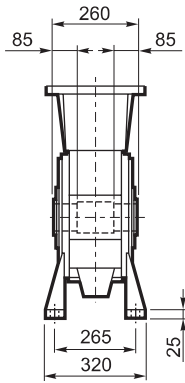

P

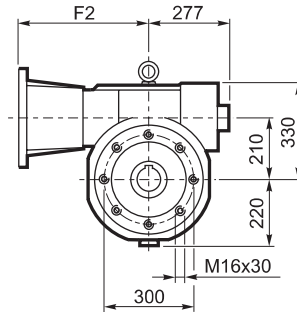
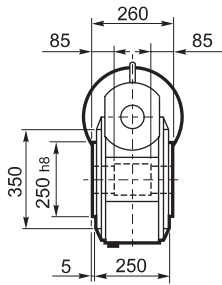

INPUT

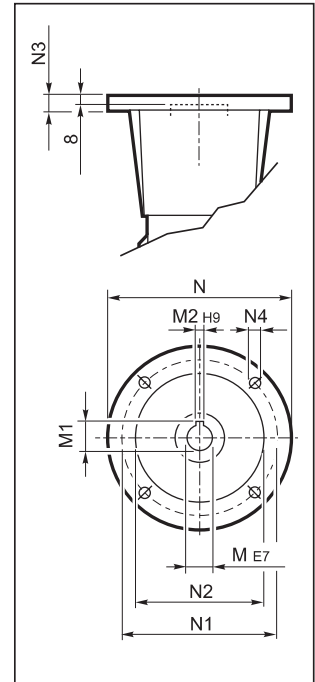

OUTPUT

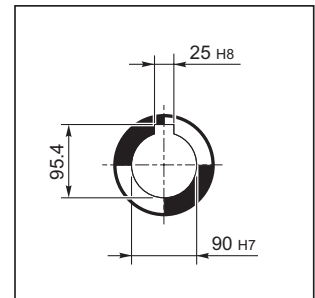

In den Ausführungen A und P wird das Lüfterrad eingebaut.
Die Motorflansch-Ausführung wird serienmäßig mit kompletter Motorkupplung geliefert.

		F2	M	M1	M2	N	N1	N2	N3	N4	
VF 210	P132 B5	485	38	41.3	10	300	265	230	25	M12	210
VF 210	P160 B5	460	42	45.3	12	350	300	250	22	18	
VF 210	P180 B5	460	48	51.8	14	350	300	250	22	18	
VF 210	P200 B5	485	55	59.3	16	400	350	300	25	M16	
VF 210	P225 B5	490	60	64.4	18	450	400	350	22	18 #	

N. 8 Bohrungen 45°

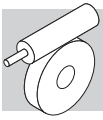

VFR 210...P (IEC)

A

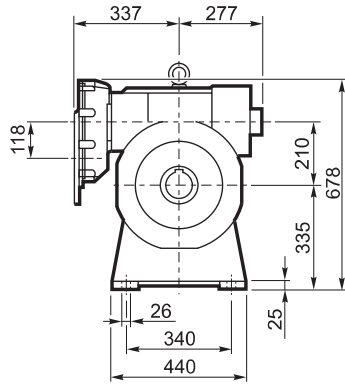
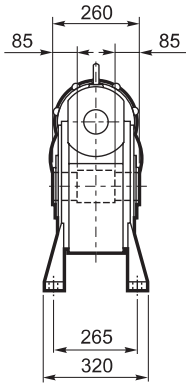

N

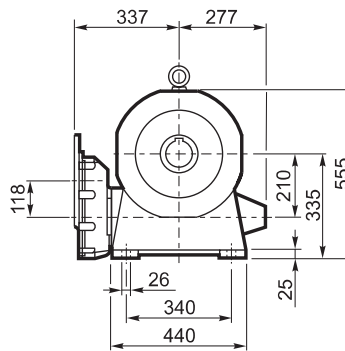
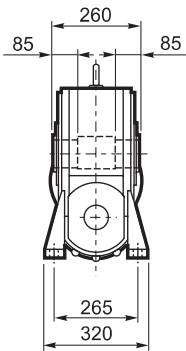

INPUT

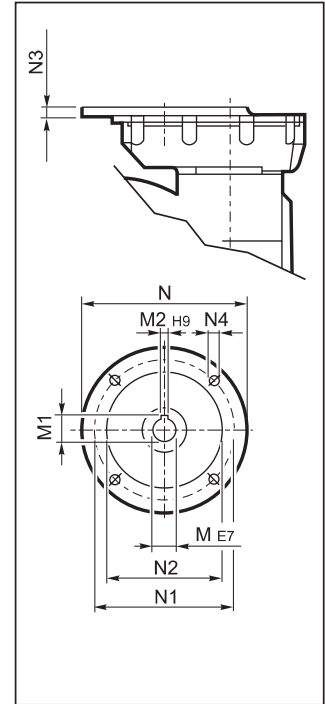

OUTPUT

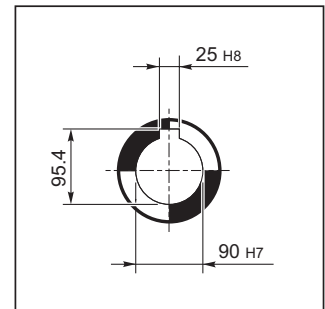

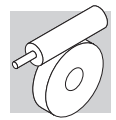

VFR 210...P (IEC)

V

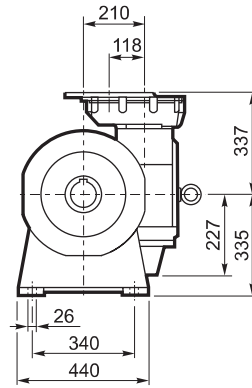
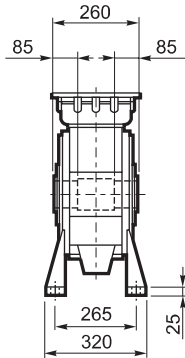

P

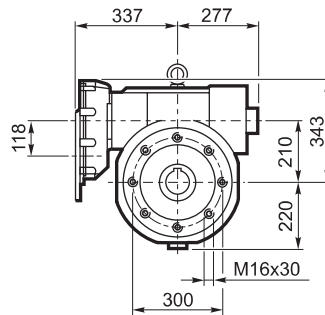
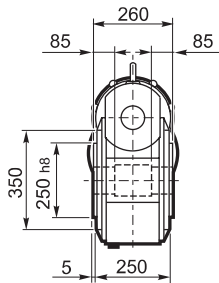

INPUT

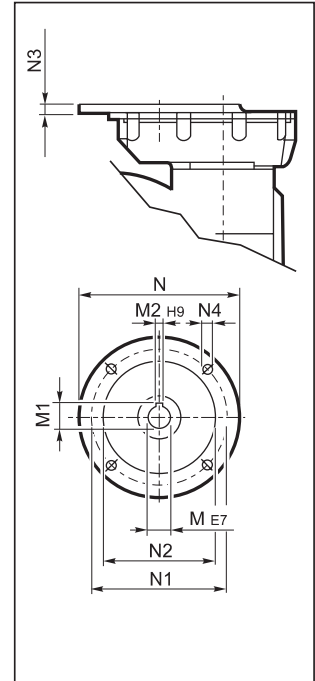

OUTPUT

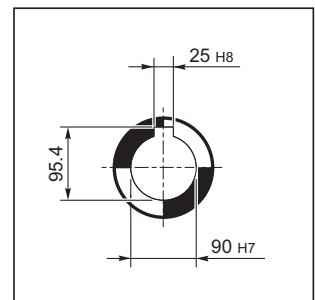

In den Ausführungen A und P wird das Lüfterrad eingebaut.

		M	M1	M2	N	N1	N2	N3	N4	
VRF 210	P100 B5	28 K6	31.3	8	250	215	180	13	M12x35	185
VRF 210	P112 B5	28 K6	31.3	8	250	215	180	13	M12x35	
VFR 210	P132 B5	38 J6	41.3	10	300	265	230	13	M12x35	
VFR 210	P160 B5	42 J6	44.3#	12	350	300	250	18	M16x60	

Verkleinertes Paßfeder

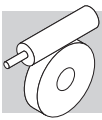

VF/VF 130/210...P (IEC)

A

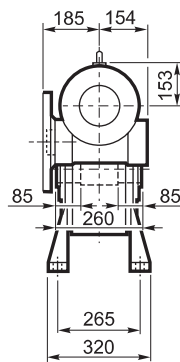
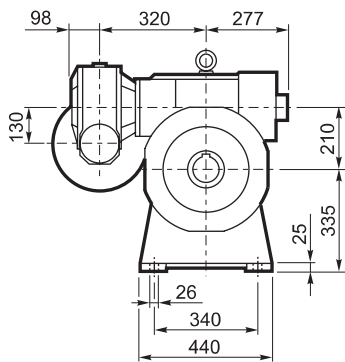

INPUT

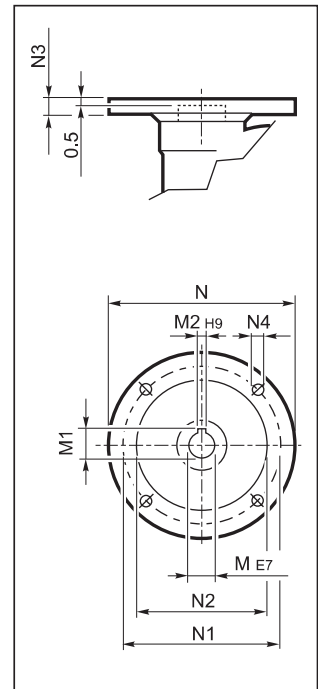

N

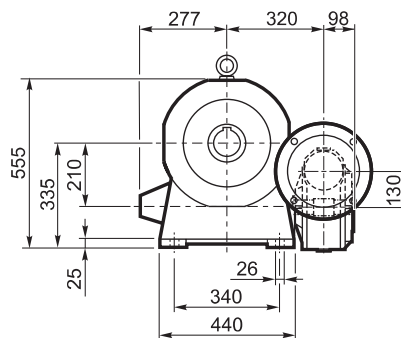
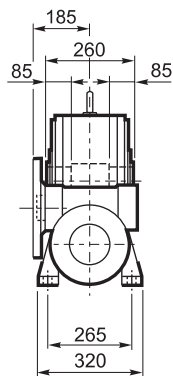

V

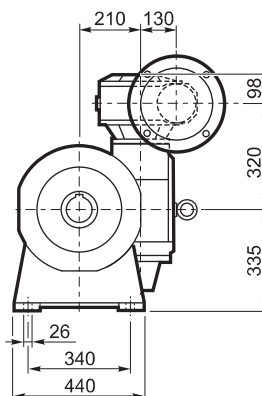
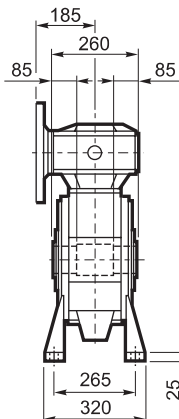

OUTPUT

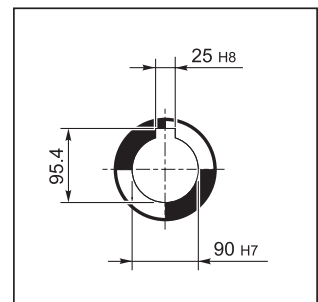

P

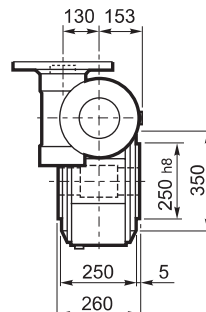
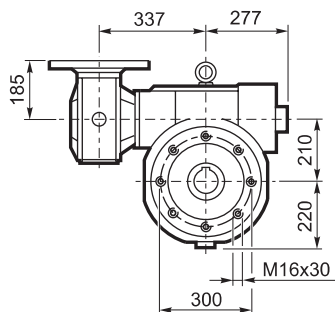

In den Ausführungen A und P wird das Lüfterrad eingebaut.

		M	M1	M2	N	N1	N2	N3	N4	
VF/VF 130/210	P90 B5	24	27.3	8	200	165	130	17	11	225
VF/VF 130/210	P100 B5	28	31.3	8	250	215	180	17	13	
VF/VF 130/210	P112 B5	28	31.3	8	250	215	180	17	13	
VF/VF 130/210	P132 B5	38	40.1#	10	300	265	230	17	13	

Verkleinertes Paßfeder

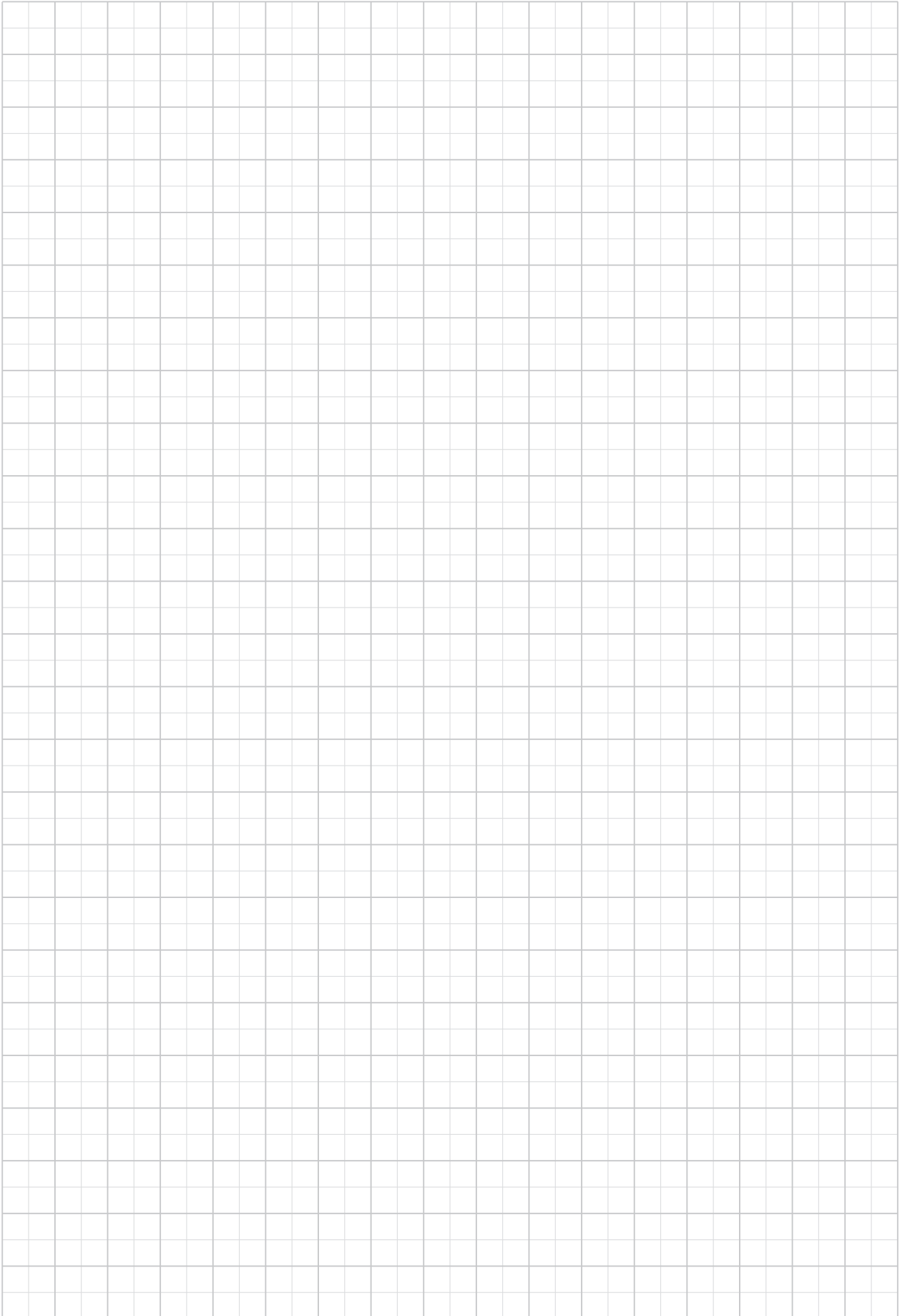
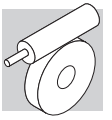

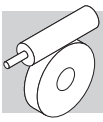

VF 250...P (IEC)

A

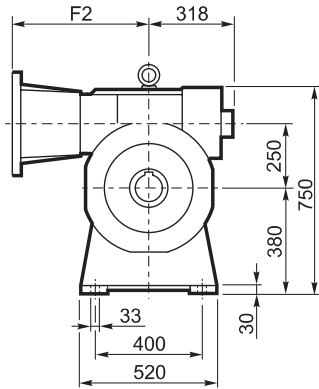
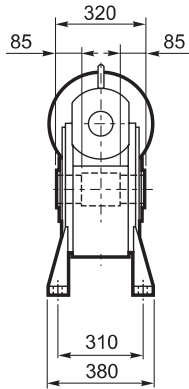

N

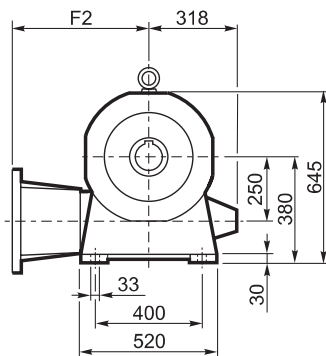
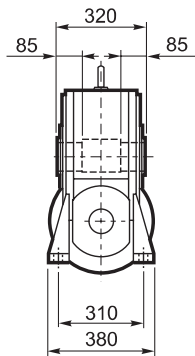

INPUT

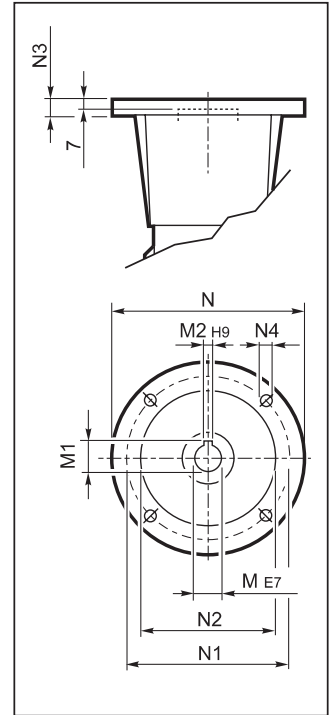

OUTPUT

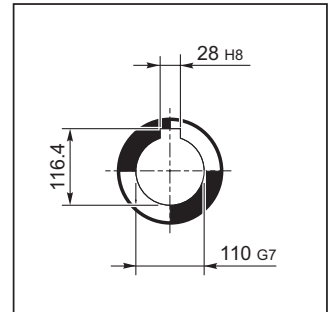

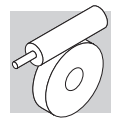

VF 250...P (IEC)

V

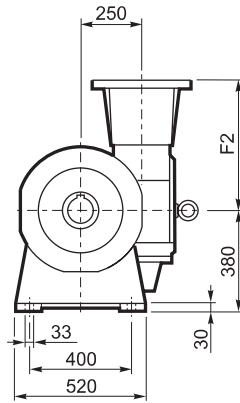
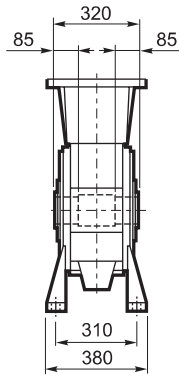

P

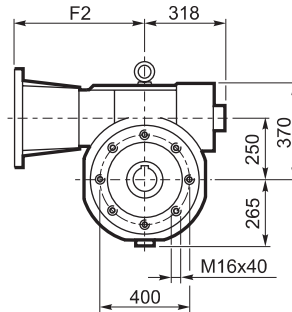
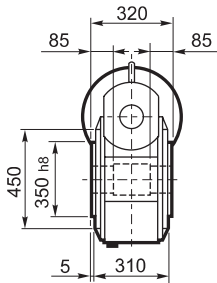

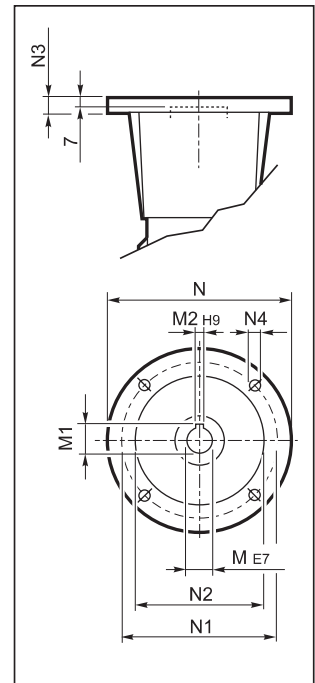

INPUT

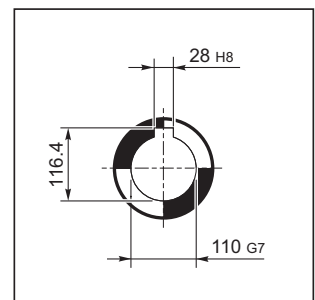

OUTPUT



In den Ausführungen A und P wird das Lüfterrad eingebaut.
Die Motorflansch-Ausführung wird serienmäßig mit kompletter Motorkupplung geliefert.

		F2	M	M1	M2	N	N1	N2	N3	N4	
VF 250	P132 B5	531	38	41.3	10	300	265	230	25	M12	310
VF 250	P160 B5	506	42	45.3	12	350	300	250	22	18	
VF 250	P180 B5	506	48	51.8	14	350	300	250	22	18	
VF 250	P200 B5	531	55	59.3	16	400	350	300	25	M16	
VF 250	P225 B5	536	60	64.4	18	450	400	350	22	18#	

N. 8 Bohrungen 45°

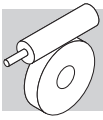

VFR 250...P (IEC)

A

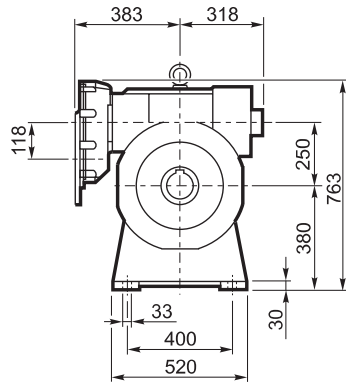
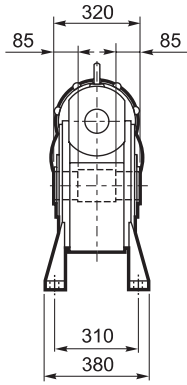

N

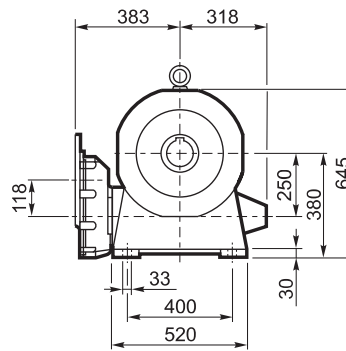
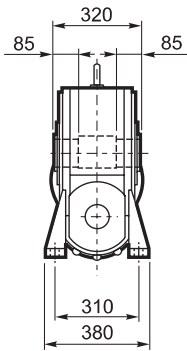

INPUT

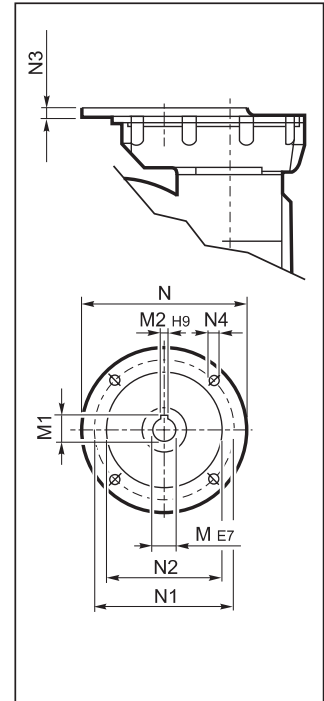

OUTPUT

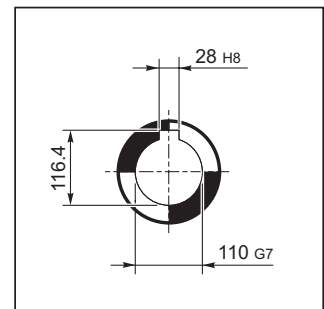

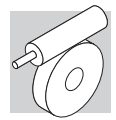

VFR 250...P (IEC)

V

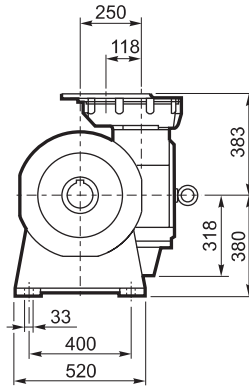
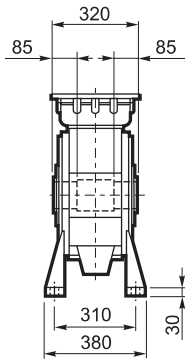

P

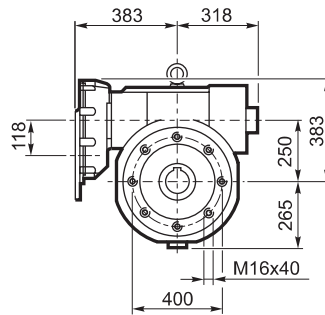
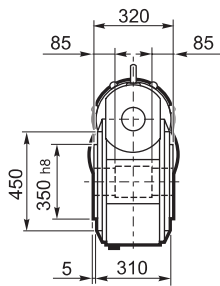

INPUT

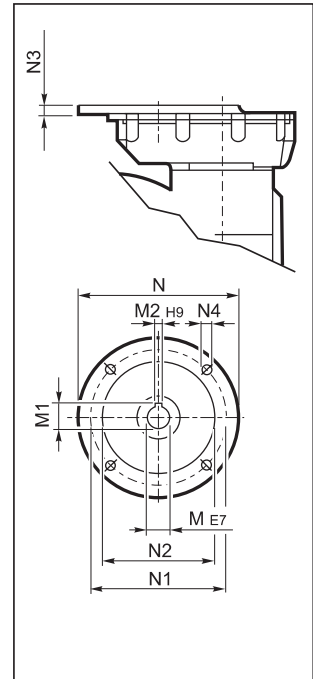

OUTPUT

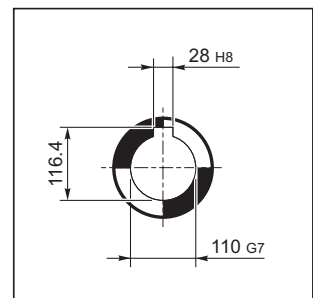

In den Ausführungen A und P wird das Lüfterrad eingebaut.

		M	M1	M2	N	N1	N2	N3	N4	kg
VFR 250	P100 B5	28 K6	31.3	8	250	215	180	13	M12x35	295
VFR 250	P112 B5	28 K6	31.3	8	250	215	180	13	M12x35	
VFR 250	P132 B5	38 J6	41.3	10	300	265	230	13	M12x35	
VFR 250	P160 B5	42 J6	44.3#	12	350	300	250	18	M16x60	

Verkleinertes Paßfeder

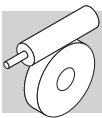

VF/VF 130/250...P (IEC)

A

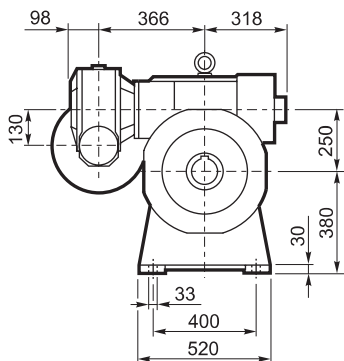

N

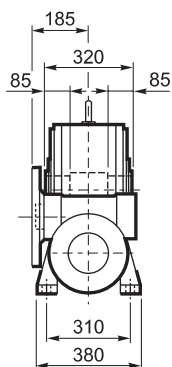

V

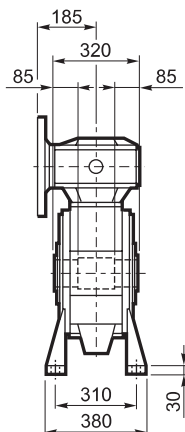

P

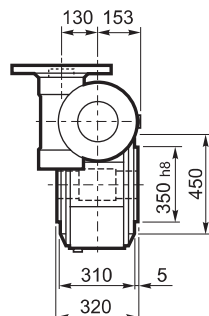
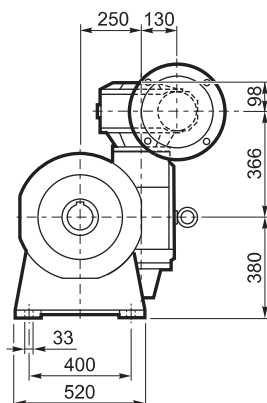
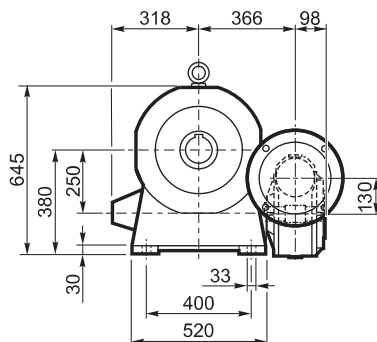
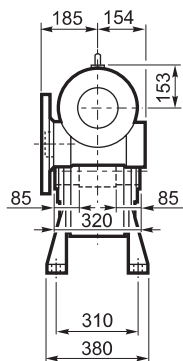
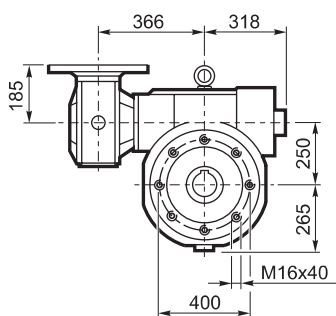

INPUT

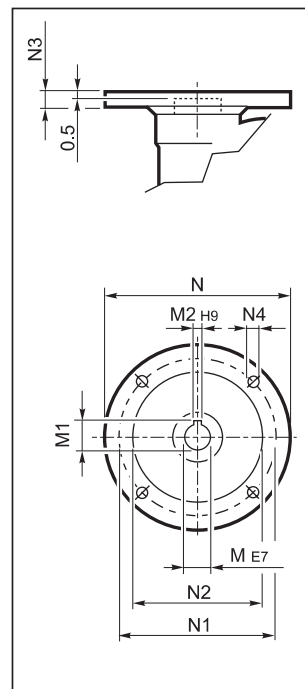

OUTPUT

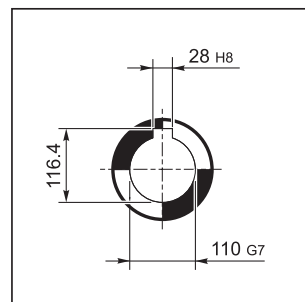

In den Ausführungen A und P wird das Lüfterrad eingebaut.

		M	M1	M2	N	N1	N2	N3	N4	
VF/VF 130/250	P 90 B5	24	27.3	8	200	165	130	17	11	325
VF/VF 130/250	P100 B5	28	31.3	8	250	215	180	17	13	
VF/VF 130/250	P112 B5	28	31.3	8	250	215	180	17	13	
VF/VF 130/250	P132 B5	38	40.1#	10	300	265	230	17	13	

Verkleinertes Paßfeder

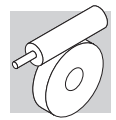

27 ABMESSUNGEN FÜR GETRIEBEN MIT CYLINDRISCHER ANTRIEBSWELLE

VF 27...HS

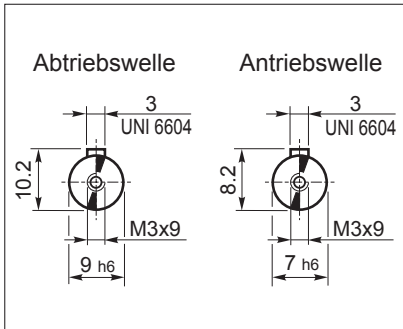

VF 27_A..HS

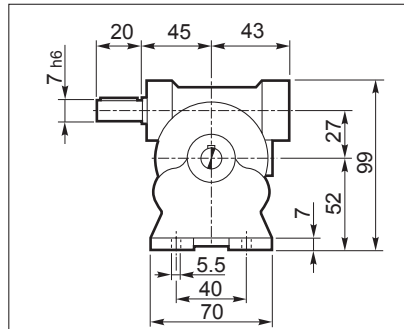

VF 27_N..HS

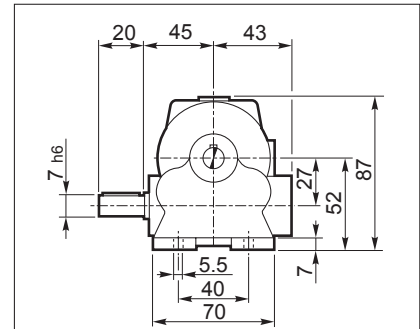

VF 27_V..HS

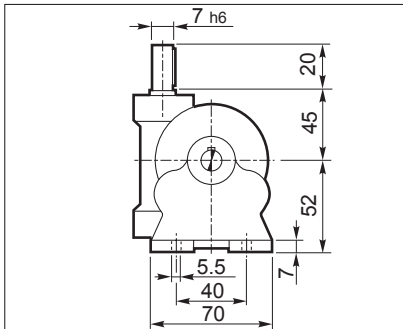

VF 27_F1..HS

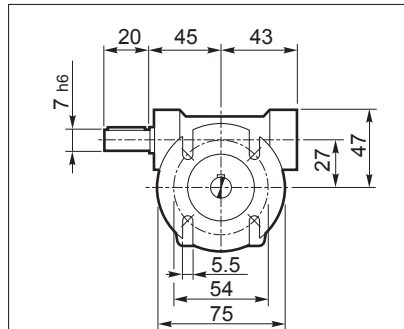

VF 27_F2..HS

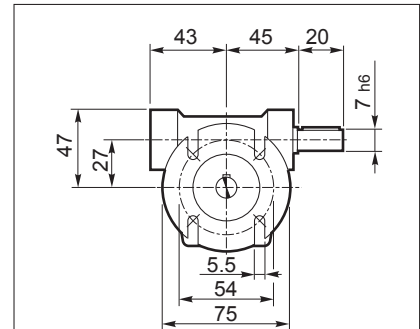

VF 27_HS	0.73

Die mit den anderen Konfigurationen gemeinen Abmessungen sind auf Seiten 107 angegeben.

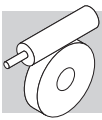

VF...HS - W...HS

VF_A..HS

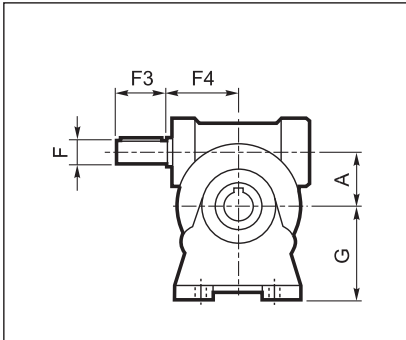

VF_V..HS

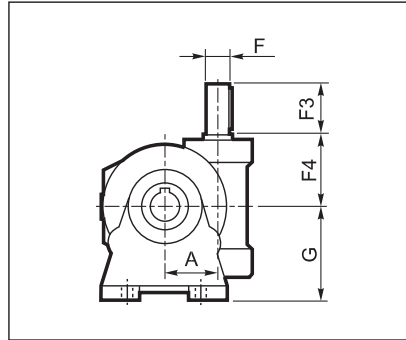

VF_N..HS

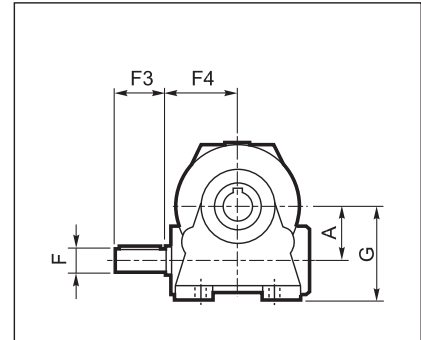

VF_P..HS

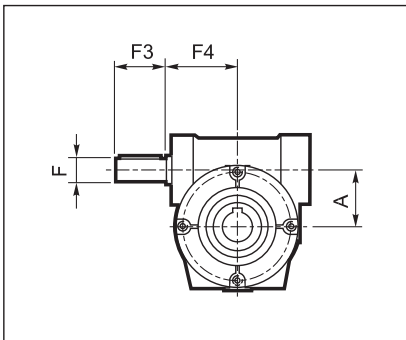

VF_FA/FC/FR/F..HS

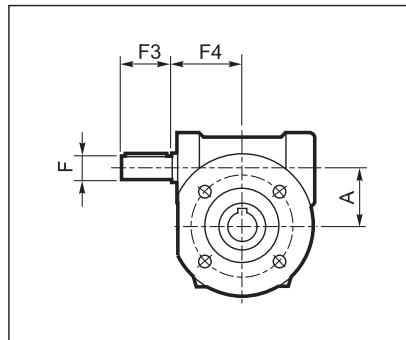

VF_U..HS

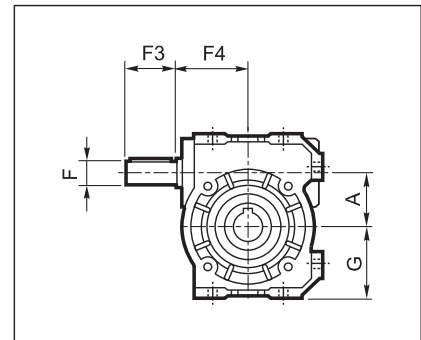

W_U..HS

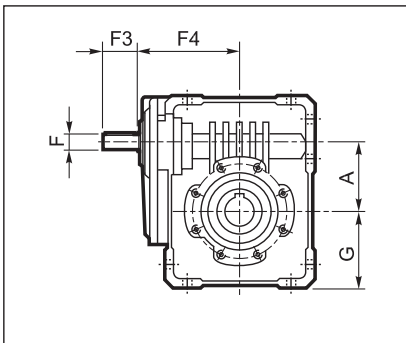

W_UF/UFC/UFCR..HS

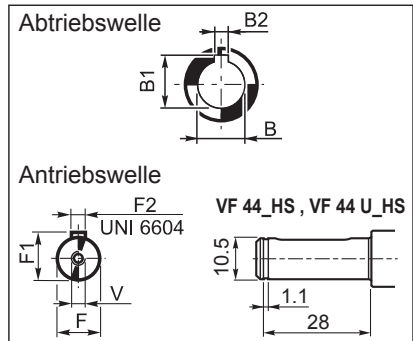
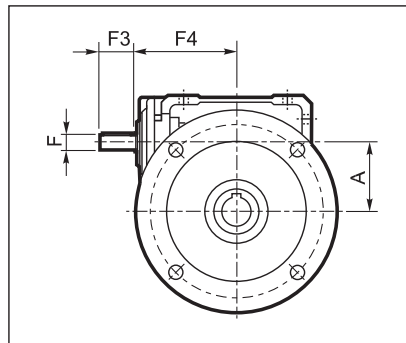

	A	B	B1	B2	F	F1	F2	F3	F4	G	V	kg
VF 30_HS	30	14 H7	16.3	5 H8	9 h6	10.2	3	20	50	55	—	1.1
VF 30_U_HS										47		
VF 44_HS	44.6	18 H7	20.8	6 H8	11 h6	12.5	4	30	54	72	—	2.0
VF 44_U_HS										55		
VF 49_HS	49.5	25 H7	28.3	8 H8	16 h6	18	5	40	65	82	M6x16	3.0
VF 49_U_HS										64.5		
W 63_HS	62.17	25 H7	28.3	8 H8	18 h6	20.5	6	40	110.5	72.5	M6x16	6.4
W 75_HS	75	30(28) H7	33.3(31.3)	8 H8	19 h6	21.5	6	40	128	87	M6x16	10.0
W 86_HS	86.9	35 H7	38.3	10 H8	25 h6	28	8	50	144	100	M8x19	14.1
W 110_HS	110.1	42 H7	45.3	12 H8	25 h6	28	8	60	168	125	M8x19	27
VF 130_HS	130	45 H7	48.8	14 H8	30 h6	33	8	60	160	195	M8x20	49
VF 150_HS	150	50 H7	53.8	14 H8	35 h6	38	10	65	185	220	M8x20	60
VF 185_HS	185.4	60 H7	64.4	18 H8	40 h6	43	12	70	214.5	254	M8x20	94
VF 210_HS	210	90 H7	95.4	25 H8	48 h6	51.5	14	110	230	335	M16x40	175
VF 250_HS	250	110 G7	116.4	28 H8	55 h6	59	16	110	275.5	380	M16x40	275

Die mit den anderen Konfigurationen gemeinen Abmessungen sind auf Seiten 122 - 183 angegeben.

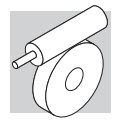

VFR...HS - WR...HS

VFR_A..HS

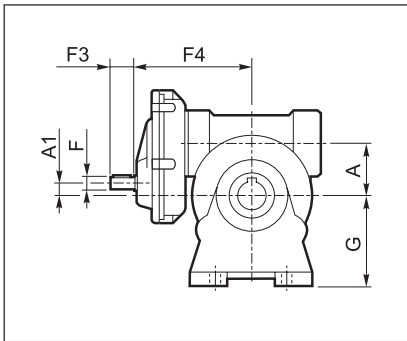

VFR_N..HS

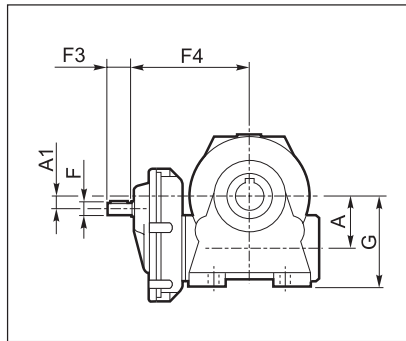

VFR_V..HS

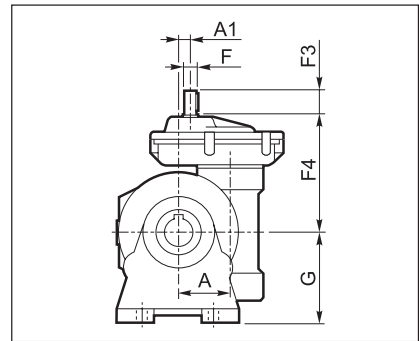

VFR_P..HS

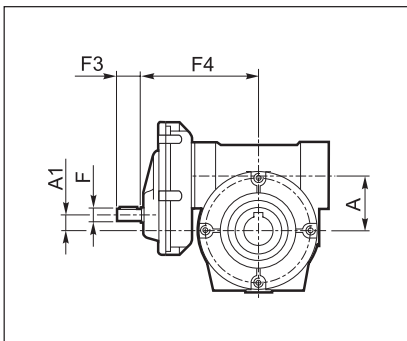

VFR_FA/FC/FR/F..HS

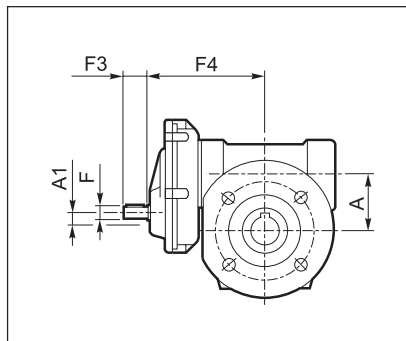

VFR_U..HS

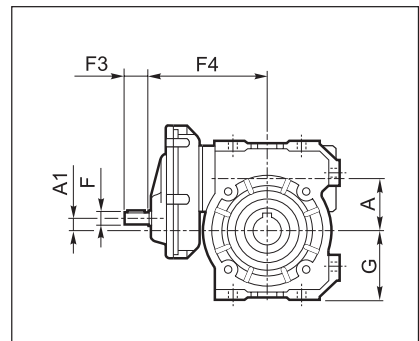

WR_U..HS

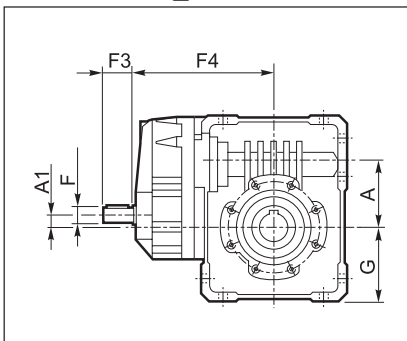

WR_UF/UFC/UFCR..HS

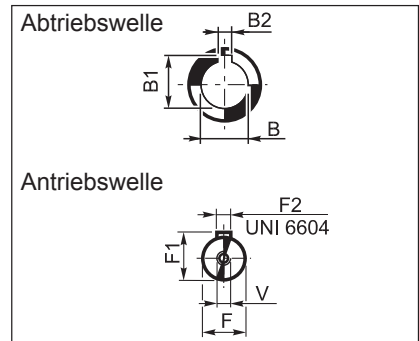
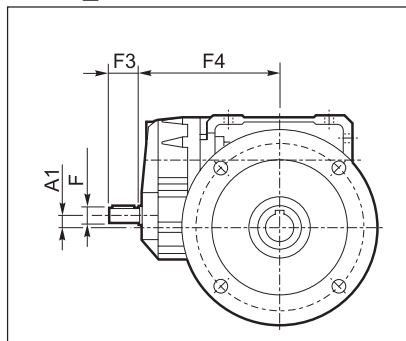

	A	A1	B	B1	B2	F	F1	F2	F3	F4	G	V	Kg
VFR 49_HS	49.5	10	25 H7	28.3	8 H8	11 h6	12.5	4	23	110	82	M4x10	5
VFR 49_U HS											64.5		
WR 63_HS	62.17	11.42	25 H7	28.3	8 H8	14 h6	16	5	30	138	72.5	M5x12.5	7.1
WR 75_HS	75	11	30(28) H7	33.3(31.3)	8 H8	19 h6	21.5	6	40	162	87	M6x16	11.1
WR 86_HS	86.9	22.9	35 H7	38.3	10 H8	19 h6	21.5	6	40	178	100	M6x16	14.7
WR 110_HS	110.1	21.1	42 H7	45.3	12 H8	24 h6	27	8	50	201	125	M8x19	34
VFR 130_HS	130	45	45 H7	48.8	14 H8	24 h6	27	8	50	228	195	M8x20	57
VFR 150_HS	150	53	50 H7	53.8	14 H8	28 h6	31	8	60	280	220	M8x20	71
VFR 185_HS	185.4	88.4	60 H7	64.4	18 H8	28 h6	31	8	60	310	254	M8x20	110
VFR 210_HS	210	92	90 H7	95.4	25 H8	38 h6	41	10	80	335	335	M10x25	185
VFR 250_HS	250	132	110 G7	116.4	28 H8	38 h6	41	10	80	383	380	M10x25	295

Die mit den anderen Konfigurationen gemeinen Abmessungen sind auf Seiten 132 - 185 angegeben.

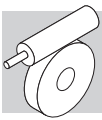

VF/VF...HS - VF/W...HS - W/VF...HS

**VF/VF_A..HS
W/VF_A..HS**

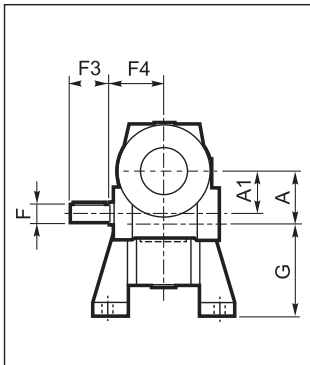

**VF/VF_N..HS
W/VF_N..HS**

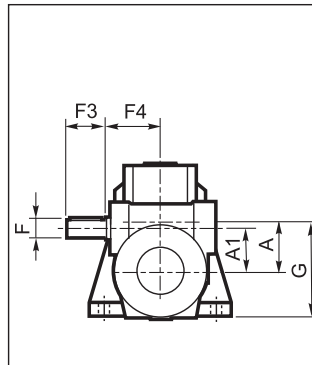

**VF/VF_V..HS
W/VF_V..HS**

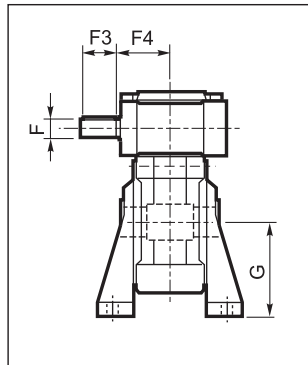

**VF/VF_P..HS
W/VF_P..HS**

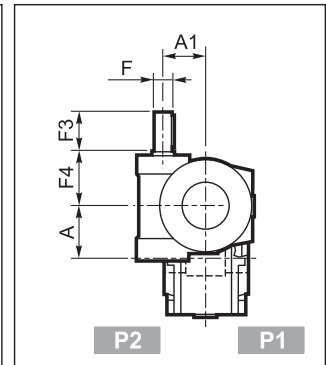

VF/W_U..HS

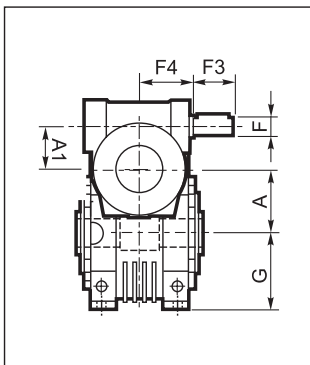

VF/VF_U..HS

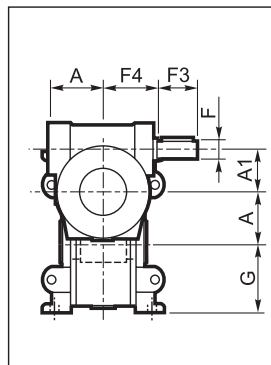

**VF/VF_F/FA/FC/FR..HS
W/VF_F/FA/FC/FR..HS**

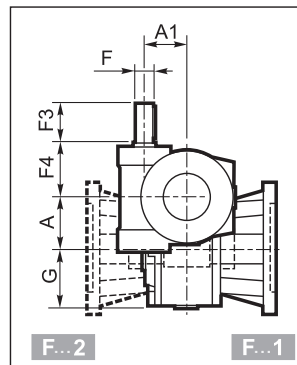

VF/W_UF/UFC/UFCR..HS

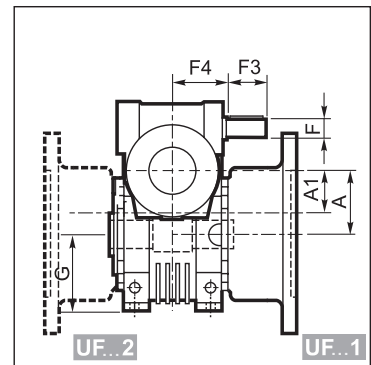

Abtriebswelle

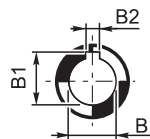

Antriebswelle

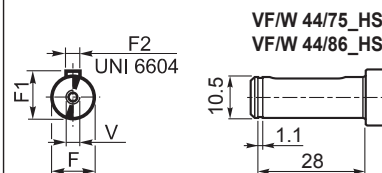

	A	A1	B	B1	B2	F	F1	F2	F3	F4	G	V	Kg
VF/VF 30/44_HS	44.6	30	18 H7	20.8	6 H8	9 h6	10.2	3	20	50	72	—	3.5
VF/VF 30/44_U_HS											55		
VF/VF 30/49_HS	49.5	30	25 H7	28.3	8 H8	9 h6	10.2	3	20	50	82	—	4.5
VF/VF 30/49_U_HS											64.5		
VF/W 30/63_HS	62.17	30	25 H7	28.3	8 H8	9 h6	10.2	3	20	50	100	—	7.5
VF/W 44/75_HS	75	44.6	30 (28) H7	33.3 (31.3)	8 H8	11 h6	12.5	4	30	54	115	—	16.1
VF/W 44/86_HS	86.9	44.6	35 H7	38.3	10 H8	11 h6	12.5	4	30	54	142	—	42
VF/W 49/110_HS	110.0	49.5	42 H7	45.3	12 H8	16 h6	18	5	40	65	170	M6x16	46
W/VF 63/130_HS	130	62.17	45 H7	48.8	14 H8	18 h6	20.5	6	40	110.5	72.5	M6x16	74
W/VF 86/150_HS	150	86.9	50 H7	53.8	14 H8	25 h6	28	8	50	144	100	M8x19	108
W/VF 86/185_HS	185.4	86.9	60 H7	64.4	18 H8	25 h6	28	8	50	144	100	M8x19	109
VF/VF 130/210_HS	210	130	90 H7	95.4	25 H8	30 h6	33	8	60	160	335	M8	225
VF/VF 130/250_HS	250	130	110 G7	116.4	28 H8	30 h6	33	8	60	160	380	M8	325

Die mit den anderen Konfigurationen gemeinen Abmessungen sind auf Seiten 128 - 186 angegeben.

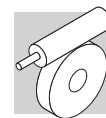

28 ABMESSUNGEN FÜR GETRIEBE MIT DREHMOMENTSTÜTZE

VF - VFR - VF/VF - W/VF

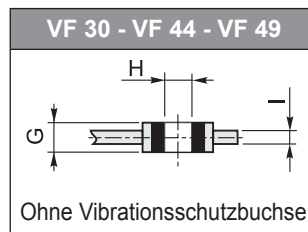
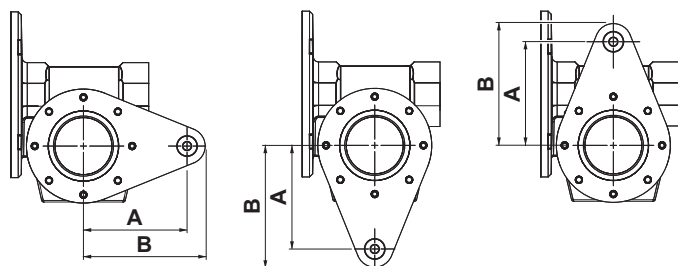

W - WR - VF/W

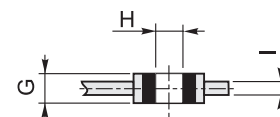
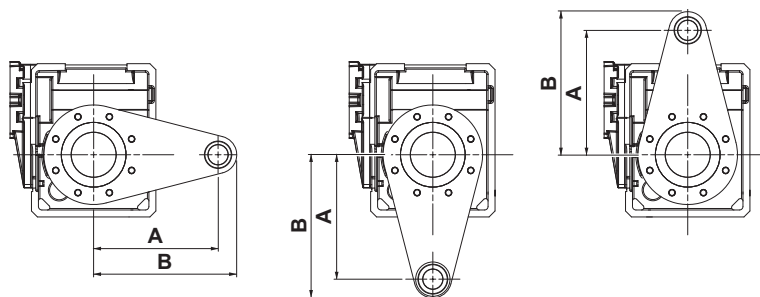

		A	B	G	H	I
VF	30	100	117.5	14	8	4
VFR	44	100	117.5	14	8	4
VF/VF	49	100	117.5	14	8	4
W	63	150	178	20	10	6
WR	75	200	237	25	20	6
VF/W	86	200	238	25	20	6
	110	250	288	25	20	6
	130	300	345	30	25	6
VF	150	300	345	30	25	6
VFR	185	350	395	30	25	6
W/VF	210	350	450	60	50	8
	250	400	500	60	50	10

Die mit den anderen Konfigurationen gemeinen Abmessungen sind auf Seiten 122 - 185 angegeben.

29 ABMESSUNGEN FÜR GETRIEBE MIT SCHUTZKAPPE

W - WR - VF/W

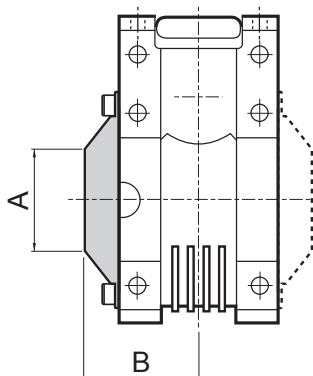

		A	B
	63	Ø 35	82
W	75	Ø 54	85.5
WR	86	Ø 71	93.5
VF/W	110	Ø 89	103

Die mit den anderen Konfigurationen gemeinen Abmessungen sind auf Seiten 136 - 150 angegeben.

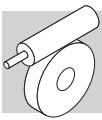

30 ZUBEHÖR

30.1 Ausgangsteckwelle

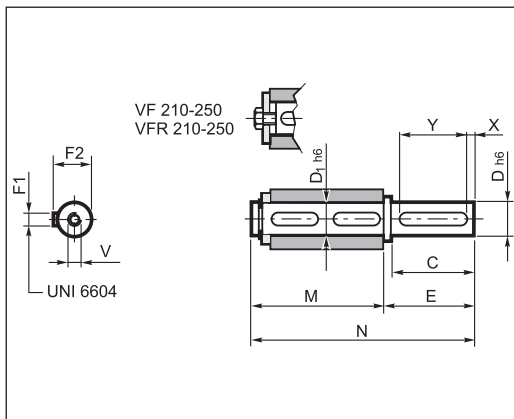

		C	D	D1	E	F1	F2	M	N	V	X	Y
VF	30	30	14	14	35	5	16	61	96	M5x13	5	20
VFR	44	40	18	18	45	6	20.5	70	115	M6x16	5	30
VF/VF	49	60	25	25	65	8	28	89	154	M8x19	5	50
	63	60	25	25	65	8	28	127	192	M8x19	5	50
W	75_D28	60	28	30	65	8	31	134	199	M8x20	5	50
WR	75_D30	60	30	30	65	8	33	134	199	M10x22	5	50
VF/W	86	60	35	35	65	10	38	149	214	M10x22	5	50
	110	75	42	42	80	12	45	164	244	M12x28	7.5	60
VF	130	80	45	45	85	14	48.5	176	261	M12x32	5	70
VFR	150	85	50	50	93	14	53.5	185	278	M16x40	7.5	70
W/VF	185	100	60	60	110	18	64	200	310	M16x40	10	80
	210	130	90	90	140	25	95	255	395	M20x50	5	120
	250	165	110	110	175	28	116	315	490	M24x64	15	140

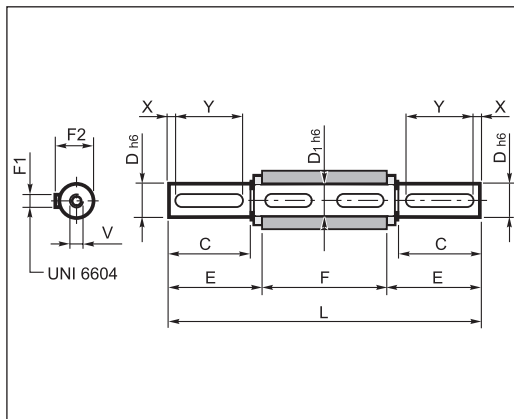

		C	D	D1	E	F	F1	F2	L	V	X	Y
VF	30	30	14	14	32.5	55	5	16	120	M5x13	5	20
VFR	44	40	18	18	42.7	64	6	20.5	149.4	M6x16	5	30
VF/VF	49	60	25	25	63.2	82	8	28	208.4	M8x19	5	50
	63	60	25	25	63.2	120	8	28	246.4	M8x19	5	50
W	75_D28	60	28	30	64	127	8	31	255	M8x20	5	50
WR	75_D30	60	30	30	64	127	8	33	255	M10x22	5	50
VF/W	86	60	35	35	64	140	10	38	268	M10x22	5	50
	110	75	42	42	79.3	155	12	45	313.5	M12x28	7.5	60
VF	130	80	45	45	84.7	165	14	48.5	334.5	M12x32	5	70
VFR	150	85	50	50	90	175	14	53.5	355	M16x40	7.5	70
W/VF	185	100	60	60	105	190	18	64	400	M16x40	10	80
	210	130	90	90	140	260	25	95	540	M20x50	5	120
	250	165	110	110	175	320	28	116	670	M24x64	15	140

30.2 Satz - Stützfüße

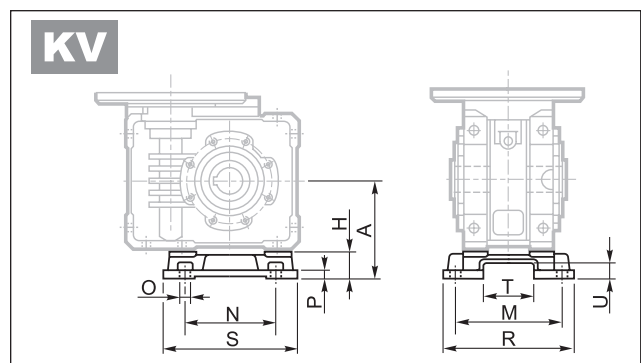
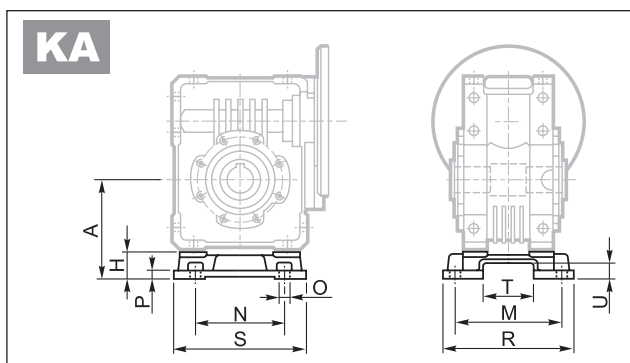

	A	H	M	N	O	P	R	S	T	U
W 63 - WR 63	100	27.5	111	95	11	8	135	145	56.5	15.5
W 75 - WR 75	115	28	115	120	11	9	139	174	56.5	15.5
W 86 - WR 86	142	42	146	140	11	11	170	200	69	20
W 110 - WR 110	170	45	181	200	13	14	210	250	69	20

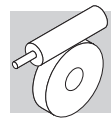

31 KUNDENSEITIGE WELLEN

Die angetriebene und mit dem Getriebe verbundene Welle sollte aus hochwertigem Stahl gemäß den Abmessungen der Tabelle gefertigt werden.

Darüber hinaus sollte die Welle axial gesichert werden, siehe folgendes Beispiel. Hierbei die einzelnen Komponenten in Abhängigkeit der verschiedenen Anforderungserfordernisse überprüfen und dimensionieren.

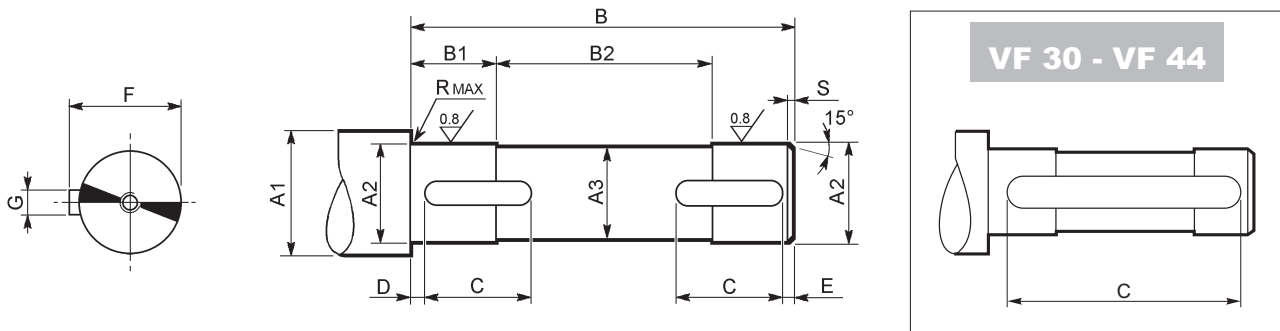

	A1	A2	A3	B	B1	B2	C	D	E	F	G	R	S	 UNI 6604
VF 30	≥ 19	14 f7	13	53	18.5	16	40	6.5	6.5	16	5 h9	0.5	1.5	5x5x40 A
VF 44	≥ 23	18 f7	17	62	22.5	17	50	6	6	20.5	6 h9	0.5	1.5	6x6x50 A
VF 49	≥ 30	25 f7	24	80	20.5	39	20	2	2	28	8 h9	1	1.5	8x7x20 A
W 63	≥ 30	25 f7	24	118	38	42	35	2	2	28	8 h9	1	1.5	8x7x35 A
W 75	≥ 35	28 f7	27	125	38	49	40	2	2	31	8 h9	1	1.5	8x7x40 A
	≥ 35	30 f7	29	125	38	49	40	2	2	33	8 h9	1	1.5	8x7x40 A
W 86	≥ 42	35 f7	34	138	43	52	40	2	2	38	10 h9	1.5	1.5	10x8x40 A
W 110	≥ 48	42 f7	41	153	43	67	50	2	2	45	12 h9	1.5	2	12x8x50 A
VF 130	≥ 52	45 f7	44	163	50.5	62	60	2.5	2.5	48.5	14 h9	2.5	2	14x9x60 A
VF 150	≥ 57	50 f7	49	173	53	67	70	2.5	2.5	53.5	14 h9	2.5	2	14x9x70 A
VF 185	≥ 68	60 f7	59	188	63	62	80	2.5	2.5	64	18 h9	2.5	2	18x11x80 A
VF 210	≥ 99	90 f7	89	258	83	92	80	3	3	95	25 h9	2.5	2.5	25x14x80 A
VF 250	≥ 121	110 h7	109	318	83	152	80	3	3	116	28 h9	2.5	2.5	28x16x80 A

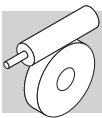

32 RUTSCHKUPPLUNG

32.1 Beschreibung

Die Rutschkupplung, die für Schneckengetriebe **VF44 - VF49** und **W63...W110**, entwickelt wurde, dient dem Schutz des Getriebes vor zufälligen Überlastungen, welche die Antriebselemente zerstören könnten.

Bezüglich traditioneller Rutschkupplungen, welche extern an das Getriebe angeschlossen werden, bietet diese Lösung folgende Vorteile:

- gleiche Aussen-Abmessungen des Getriebes wie das Standard Gehäuse
- wartungsfrei, da das System in Ölbad arbeitet
- das maximal übertragbare Moment kann einfach, per Hand, von aussen eingestellt werden
- ständiges Rutschen verursacht keinen Schaden, da die mechanischen Teile im Ölbad laufen.



Von einer Montage in Hebemechanismen wird abgeraten.

32.2 Funktionsweise

Die Rutschkupplung arbeitet wie eine doppelkonische Reibfläche, die direkt auf einen aus Sphäroguss bestehenden Innenring GS 400/12 des Bronzeschneckenrades wirkt.

Die axiale Anpresskraft, die die konischen Reibflächen zusammendrückt, wird von Tellerfedern erzeugt.

Die Einstellung des Rutschmomentes kann in einer einfachen Weise durch Drehen einer Verstellmutter, ausserhalb des Getriebes, erreicht werden.

32.3 Schutz der Arbeitsmaschine vor Überlastungen:

Die Rutschkupplung ist eingestellt auf das notwendige Moment der Arbeitsmaschine und schützt alle mechanischen Teile der Übertragungseinheit. Weiter vermeidet sie Beschädigungen hervorgerufen durch mögliche Überlastungen.

32.4 Auskuppeln bei Selbsthemmung

In einigen Anwendungsfällen ist es nötig die Ausgangswelle des Getriebes zu drehen während die Arbeitsmaschine steht: Dies ist bei einem normalen Schneckengetriebe nicht möglich. Die Verwendung der Rutschkupplung macht es möglich, wenn vorher die Verstellmutter gelöst wird.

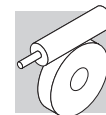

32.5 VF...L, W...L

L1								L2								
	N	A	V	U	F1 FC1 FR1 FA1	F2 FC2 FR2 FA2**	P1 P2		N	A	V	U	F1 FC1 FR1 FA1**	F2 FC2 FR2 FA2	P1 P2	
VF VF/VF*									VF VF/VF*							
	U	UF1 UFC1	UF2 UFC2	UFCR1	UFCR2				U	UF1 UFC1	UF2 UFC2	UFCR1	UFCR2			
W VF/W*									W VF/W*							

* In den Doppelschneckengetrieben Typ VF/VF ist das Drehmomentstutz auf das 2te Getriebe für die Ausführungen L1 oder L2 installiert; es ist auf das 1te Getriebe für Ausführung LF installiert.

LF				
	VF/W	44/75	44/86	49/110
	W/VF	63/130	86/150	86/185

Wenn nicht anders angegeben, werden die Getriebe VF...L geliefert mit der Verstellmutter links (L1), mit Sicht auf den E-Motor.

32.6 Abmessungen

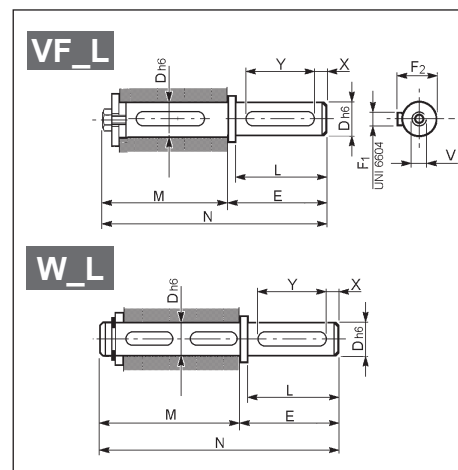
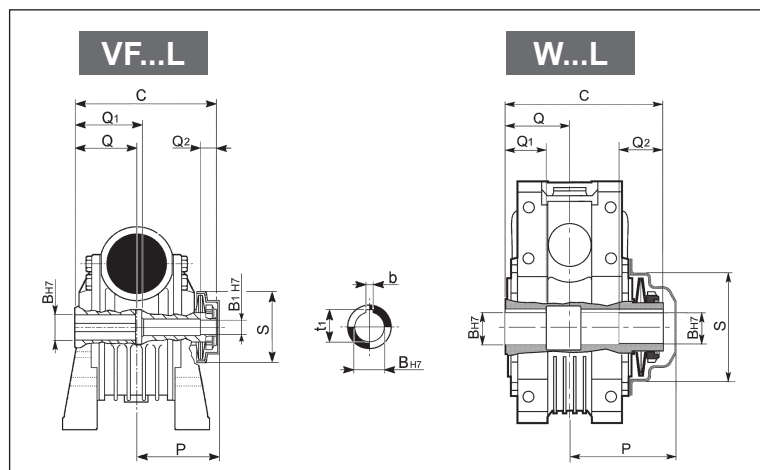

	Rutschkupplung										Ein freies Wellenende									
	C	Q	Q1	Q2	P	S	B _{H7}	B _{1H7}	t ₁	b	L	D _{h6}	E	F1	F2	M	N	V	X	Y
VF 44L	79	27	32	12	48	42.5	18	11	20.8	6	40	18	45	6	20.5	86	131	M6x16	5	30
VF 49L	105	47	51	15	63.5	66.5	25	14	28.3	8	60	25	65	8	28	114.5	179.5	M8x19	5	40
W 63L	145	60	40	40	100	77	25	-	28.3	8	60	25	65	8	28	152	217	M8x19	5	50
W 75L_D30	154.5	63.5	40	40	104	100	30	-	33.3	8	60	30	65	8	33	161.5	226.5	M10x22	5	50
W 86L	170	70	50	45	113	119	35	-	38.3	10	60	35	65	10	38	179	244	M10x22	5	50
W 110L	191	77.5	55	45	133	134	42	-	45.3	12	75	42	80	12	45	200	280	M12x28	7.5	60

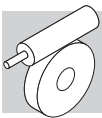

32.7 Rutschmomenteinstellung

Eine Voreinstellung des Rutschmoments wird im Werk durchgeführt.

Das voreingestellte Moment entspricht dem im Katalog angegebenen Nennmoment Mn_2 [$n_1=1400$] des Getriebes Typ VF oder W.

Nachfolgend werden die im Werk durchgeführten Arbeiten zur Einstellung des Rutschmoments beschrieben.

Die gleichen Schritte, mit Ausnahme des Schrittes Nr. 2, müssen wiederholt werden, wenn ein anderer Momentwert benötigt wird.

1. Die Verstellmutter so weit anziehen, daß sich die Tellerfedern nicht mehr von Hand drehen lassen.

2. Es werden 2 Bezugsmarkierungen unter dem gleichen Winkel sowohl auf der Verstellmutter als auch auf der Hohlwelle angebracht.

Die hiermit gekennzeichnete Stellung ist der Ausgangspunkt für jede weitere Rutschmomenteinstellung durch die Verdrehung der Verstellmutter.

3. Die Verstellmutter wird soweit angezogen, bis das gewünschte Nennmoment Mn_2 des Getriebes erreicht ist. Sollte ein anderes Rutschmoment erforderlich sein, ist gemäß folgendem Diagramm (ausgehend von Punkt 2.) die Verstellmutter um den angegebenen Wert gegenüber der Hohlwelle zu drehen ($\frac{1}{4}$ bis 2 Umdrehungen).

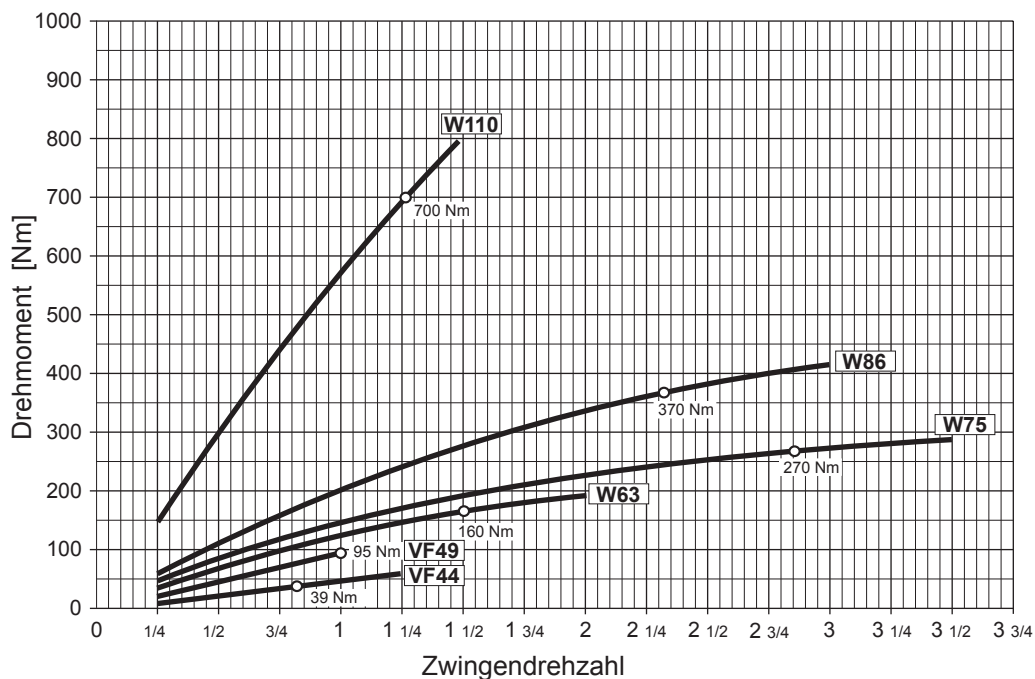

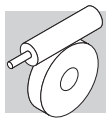

VF-EP / W-EP - GETRIEBE FÜR RAUE UMGEBUNGEN

33 DIE VORTEILE DER EP-VERSION FÜR DIE INDUSTRIE

Alle Unternehmen der Lebensmittel- und Getränke-, Chemie- und Pharmaindustrie können sich jetzt auf eine neu entwickelte Getriebemotorenreihe verlassen, die für den effizienten Betrieb in den äußerst hygienischen und rauen Umgebungen, die diese Sektoren kennzeichnen, ausgelegt ist.

HAUPTZEIGENSCHAFTEN

Ideal für die Industrie der Nahrungsmittelverarbeitung

Widerstandsfähig gegen Korrosion

Auch für die härtesten Umgebungsbedingungen angemessener Betrieb

Unter Anwendung der am häufigsten verwendeten Reinigungsmitteln waschbar/hygienisch säuberungsfähig.

Standard:

- Hohlwelle, Befestigungsmaterial aus Edelstahl
- Vollständig abgedichtetes Getriebe (nicht entlüftet)
- Nicht benutzte Gewindebohrungen mit Verschlußstopfen verschlossen
- Spezifische Wasserablauföffnungen
- Motorschutzart IP56
- C5 Korrosionsschutz oder von der FDA und NSF zugelassene Lackierung

Hauptoptionen:

- Abwaschbare Dichtringe
- Von NSF (H1) und FDA zugelassenes Schmiermittel für Lebensmittelindustrie

HAUPTVORTEILE DER EP - VERSION

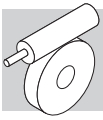

Dank des vollständig abgedichteten Getriebegehäuses, der Oberflächenlackierung und des -schutzes gewährleisten Getriebemotoren der EP-Serie einen gefahrlosen Betrieb in rauen und hygienischen Umgebungen und erleichtern die Desinfektionsprozesse des Getriebemotors.

Der gesamte Getriebemotor ist durch eine mehrschichtige Hochleistungs-Epoxidbeschichtung mit erhöhter Korrosions- und Abriebfestigkeit geschützt.

Es können zwei verschiedene Deckbeschichtungen ausgewählt werden:

- Die Erste garantiert Korrosionsschutzklasse C5 gemäß ISO 9223 und ist standardmäßig in RAL9006 verfügbar.
- Die Zweite ist speziell für die Lebensmittel- und Getränkeindustrie bestimmt und von NSF und FDA als kompatibel für die Verwendung in gelegentlichen Lebensmittelkontaktbereichen sowie für den Kontakt mit Trinkwasser registriert. Neben einer verbesserten Korrosionsbeständigkeit ist diese Lackierung auch gegen die meisten in der Lebensmittel- und Getränkeindustrie üblichen Reinigungsmittel beständig.

HINWEIS: Diese Endbearbeitung wird automatisch ausgewählt, wenn die für den Getriebemotor angegebenen Farben Hellblau * (PLB) oder Weiß * (PWH) sind.

* Hinweis: Es kann keine RAL-Farbe angegeben werden, da der Lack organisch.

Schließlich kann der EP-Getriebemotor durch verschiedene Optionen und Montagezubehör weiter an die jeweiligen Anforderungen angepasst werden.

Baugrößen in EP-Version erhältlich: 44 (außer VFR), 49, 63, 75, 86.

Erhältliche EP-Motoren: 0,12 bis 4 kW, sowohl kompakt als auch IEC, 2-, 4- und 6-polig.

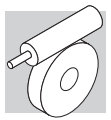

AUSSTATTUNG DER GETRIEBE

- ① Das Getriebe ist vollkommen versiegelt, um so jegliche eventuelle Verschmutzung der Umgebung zu reduzieren.
- ② Hohle Abtriebswelle in rostfreiem Stahl AISI 316.
- ③ Identifikationsschild und Schrauben in Edelstahl.
- ④ Spezielle Gehäusekonstruktion zur Erleichterung des Wasserdrainage
- ⑤ Optional ist ein von NSF registriertes Schmiermittel der Klasse H1 für die Lebensmittel- und Pharmaindustrie erhältlich. Es entspricht den FDA-Bestimmungen für den gelegentlichen Kontakt mit Lebensmitteln.

- ⑥ Dichtungen mit doppelter Dichtlippe und Edelstahl Abschirmung für Reinigung verfügbar.
- ⑦ Aussenflächen sind mit einem 2K Epoxid-Lack grundiert und lackiert, der eine FDA und eine NSF Zulassung (in Abhängigkeit von der Farbauswahl) für gelegentliche Berührungen mit Lebensmittel hat.
- ⑧ Verschluss der nicht verwendeten Gewindebohrungen mit Eindrückstößeln.

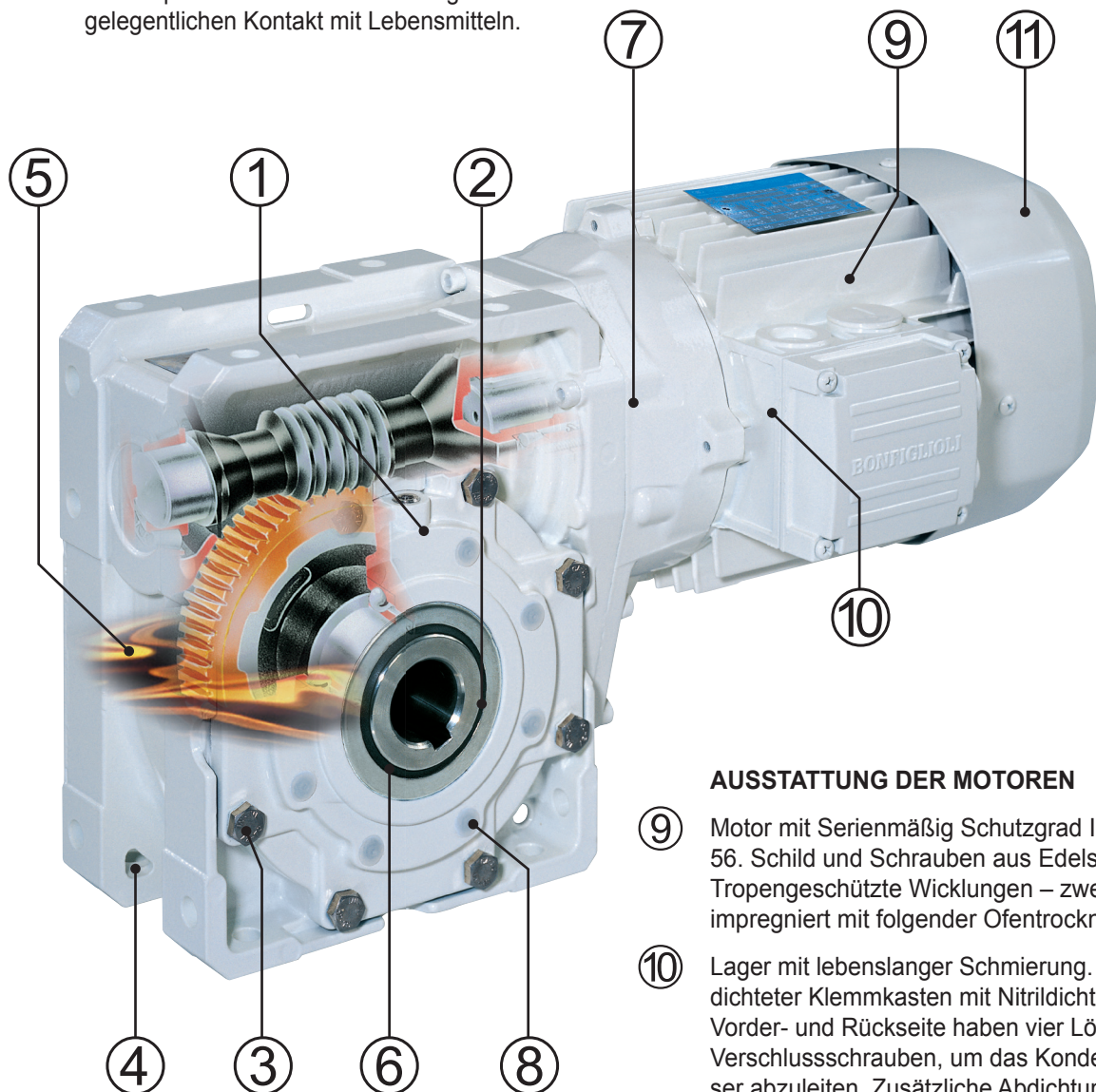

AUSSTATTUNG DER MOTOREN

- ⑨ Motor mit Serienmäßig Schutzgrad IP 56. Schild und Schrauben aus Edelstahl. Tropengeschützte Wicklungen – zweifach impregniert mit folgender Ofentrocknung.
- ⑩ Lager mit lebenslanger Schmierung. Abgedichteter Klemmkasten mit Nitrildichtungen. Vorder- und Rückseite haben vier Löcher mit Verschlusschrauben, um das Kondenswasser abzuleiten. Zusätzliche Abdichtung für den Kupplungsbereich des Getriebes.
- ⑪ Kühllüfterrad in Polyamid-Material, nahrungsmittelverträglich.

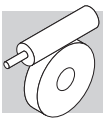

GETRIEBE

W-EP — 63 U 30 P90 B14 B3 PWH

OPTIONEN

LACKIERUNG

NP* unlackiert	
PWH (FDA & NSF konform)	
PLB (FDA & NSF konform)	
RAL9006 (Hohe Korrosionsbeständigkeit C5)	

EINBAULAGEN

VF-EP 44 VF-EP 49	B3
W-EP 63 W-EP 75 W-EP 86	B3 (default), B6, B7, B8, V5, V6

MOTOR BAUFORM

B5, B14 (IEC standard)

BEZEICHNUNG DER ANTRIEBSSEITE

	VF-EP	VF-EP R	W-EP	W-EP R
P(IEC)	 P63...P80	 P63	 P71...P112	 P63...P90
S_			 S1...S3	

ÜBERSETZUNG

BAUFORM

GETRIEBEBAUGRÖSSE

VF-EP: **44, 49**

W-EP: **63, 75, 86**

— (blank)

R (Vorstufe VF-EP 44)

GETRIEBE TYP

VF-EP

W-EP

* Hinweis: Wenn das Getriebe in der Ausführung NP (unlackiert) mit Drehmomentstütze gewünscht wird, ist diese mit einer hellgrauen Grundierung versehen, die vollständig überlackierbar ist.

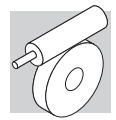

MOTOR

BN-EP 80B 4 B14 230/400-50 CLF PWH

OPTIONEN

LACKIERUNG

NP* unlackiert	
PWH (FDA & NSF konform)	
PLB (FDA & NSF konform)	
RAL9006 (Hohe Korrosionsbeständigkeit C5)	

KLEMMKASTENLAGE
W (default), **N, E, S**

ISOLIERUNGSKLASSE
CL F Standard
CL H Option

SPANNUNG - FREQUENZ

BAUFORM
— (Kompaktmotor)
B5, B14 (motore IEC)

POLZAHL
2, 4, 6,

MOTOR-BAUGRÖSSE
1SC ... 3LC (Kompaktmotor)
63 ... 112 (IEC - Motor)

MOTORTYP

M-EP = Dreiphasen Kompaktmotor
BN-EP = Dreiphasen IEC Motor

ME-EP = Dreiphasen Kompaktmotor, klasse IE2
BE-EP = Dreiphasen IEC Motor, klasse IE2

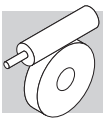

35 GETRIEBE OPTIONEN

PX

Option Dichtringe an der Abtriebswelle. Die speziellen, als Option angebotenen Dichtringe erweitern die Applikationsmöglichkeiten der Getriebe auch auf solche Prozesse, in denen häufig mit Wasserdruckstrahlern gewaschen wird. Die externe Abschirmung in EDELSTAHL und die Realisierung mit doppelter Dichtlippe steuern zur Grundfunktionalität noch die Widerstandsfähigkeit gegen den Umgebungsdruck bei, während das besondere, dafür verwendete Material (PTFE) einen hervorragenden Widerstand gegen aggressiv wirkende chemische Elemente, einen niedrigen Reibungskoeffizienten und lange Lebensdauer garantiert.

PV

Dichtringe in Fluor-Elastomer an der Abtriebswelle. Innere Feder in Edelstahl.

UH1

Option nahrungsmittelverträgliche Öle. Das Getriebe ist werksseitig mit Schmiermittel für eine lange Lebensdauer gefüllt, für den gelegentlichen Kontakt mit Lebensmitteln zugelassen und von der NSF als H1 für die Lebensmittel- und Pharmaindustrie zugelassen. Es erfüllt außerdem die Normen der FDA 21 CFR Sec. 178.3570. Seine synthetische Herkunft auf Poliglykol-Basis erweitert nicht nur den Einsatz auf einen breiter angelegten Temperaturbereich (-25° C bis auf + 150° C) sondern macht es möglich, dass hier ein regelmäßiger Austausch nicht mehr erforderlich ist und daher sich die Schmiermittelfüllung, in Abwesenheit von verschmutzenden Stoffen, als auf „Lebenszeit“ versteht.

NACHWEISE

AC - Konformitätsbescheinigung Dokument mit dessen Ausstellung die Konformität des Produkts mit dem Auftrag, und dessen Konstruktion in Konformität mit den vom Qualitätsmanagementsystem von Bonfiglioli Riduttori vorgesehenen Standardfertigungs- und -kontrollverfahren bescheinigt wird.

CC – Prüfzeugnis

Die Bestellung führt zur Durchführung von Kontrollen der Konformität mit dem Auftrag, allgemeinen Sichtkontrollen und instrumentalen Prüfungen der Passmaße. Des Weiteren werden allgemeine Betriebskontrollen bei Leerlauf sowie Prüfungen der Funktionalität der Dichtungen bei Stillstand und während des Betriebs durchgeführt. Die Prüfung wird anhand einer Stichprobe des Versandloses durchgeführt.

36 OPTIONEN MOTOREN

Die verfügbaren Optionen für alle EP-Motoren sind: **D3, E3, K1, H1, NH1, RC, RV, ACM, CC, CUS, S2, S3, S9.**

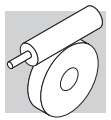

Detaillierte Informationen entnehmen Sie bitte dem Kapitel "Elektromotoren".

37 WEITERE INFORMATIONEN ÜBER GETRIEBE UND GETRIEBEMOTOREN

Einbaulagen, technische Daten, Motorverfügbarkeiten, Trägheitsmomente und Abmessungen für die **VF-EP** und **W-EP** Serie unterscheiden sich nicht von der Standard-Serie **W** und **VF**. Ebenso ändern sich die Informationen über EP-Motoren gegenüber gleichwertigen Serienmotoren nicht. Alle Informationen sind in den entsprechenden Kapitel des Kataloges zu finden.

38 ZUBEHÖR DER SERIE EP

Für das Getriebe kann, dem entsprechenden Einsatz gemäß, bestimmtes Zubehör angefordert werden, dass die Architektur des Produkts vervollständigt. Dabei handelt es sich insbesondere um:

- Abtriebswelle, sowohl einfach als zweiseitig, aus EDELSTAHL, Typ 316, komplett mit Keilen aus dem gleichen Material.
- Reaktionsarm aus lackiertem Blech (Geben Sie das Akronym in der zugehörigen Abbildung an).
- Sicherheitsabdeckung aus Kunststoff für den Bereich der (hohlen) Abtriebswelle (W63,W75 und W86) oder aus gummibeschichtetem Blech NBR (VF 44,VF 49) mit Schrauben aus EDELSTAHL und einem Schutzgrad von insgesamt IP56.

38.1 Ausgangssteckwelle

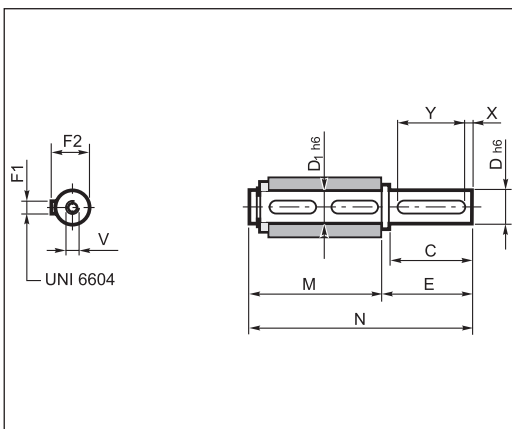

	C	D	D1	E	F1	F2	M	N	V	X	Y
VF-EP 44	40	18	18	45	6	20.5	70	115	M6x16	5	30
VF-EP 49 VF-EP R 49	60	25	25	65	8	28	89	154	M8x19	5	50
W-EP 63 W-EP R 63	60	25	25	65	8	28	127	192	M8x19	5	50
W-EP 75 W-EP R 75	60	30	30	65	8	33	134	199	M10x22	5	50
W-EP 86 W-EP R 86	60	35	35	65	10	38	149	214	M10x22	5	50

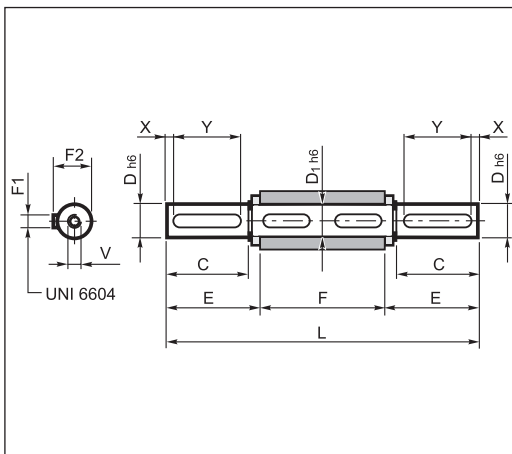

	C	D	D1	E	F	F1	F2	L	V	X	Y
VF-EP 44	40	18	18	42.7	64	6	20.5	149.4	M6x16	5	30
VF-EP 49 VF-EP R 49	60	25	25	63.2	82	8	28	208.4	M8x19	5	50
W-EP 63 W-EP R 63	60	25	25	63.2	120	8	28	246.4	M8x19	5	50
W-EP 75 W-EP R 75	60	30	30	64	127	8	33	255	M10x22	5	50
W-EP 86 W-EP R 86	60	35	35	64	140	10	38	268	M10x22	5	50

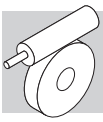

38.2 Drehmomentstütze

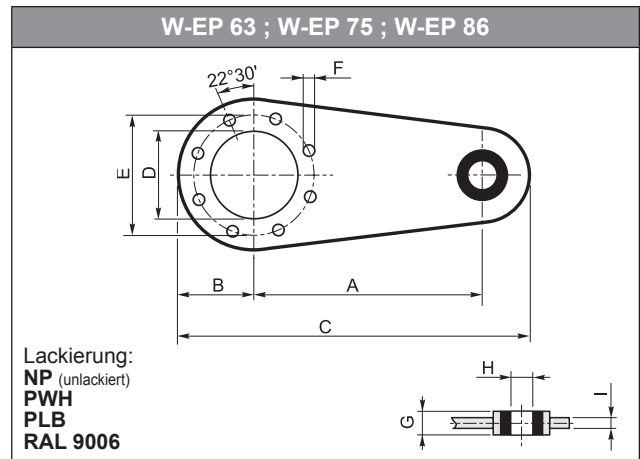
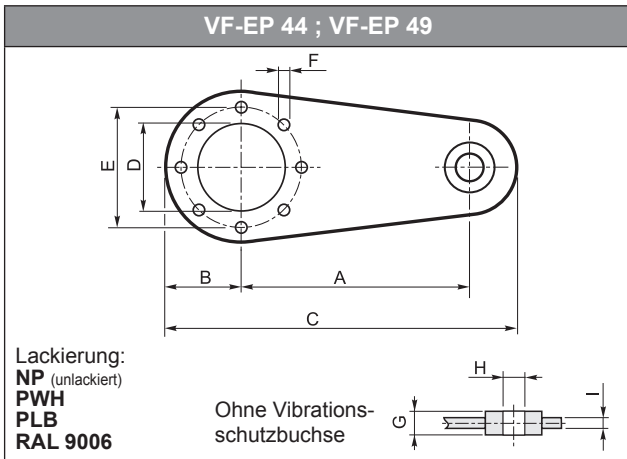

	A	B	C	D	E	F	G	H	I
VF-EP 44	100	40	157.5	50	65	7	14	8	4
VF-EP 49 VF-EP R 49	100	55	172.5	68	94	7	14	8	4
W-EP 63 W-EP R 63	150	55	233	75	90	9	20	10	6
W-EP 75 W-EP R 75	200	63	300	90	110	9	25	20	6
W-EP 86 W-EP R 86	200	80	318	110	130	11	25	20	6

38.3 Schutzdeckel

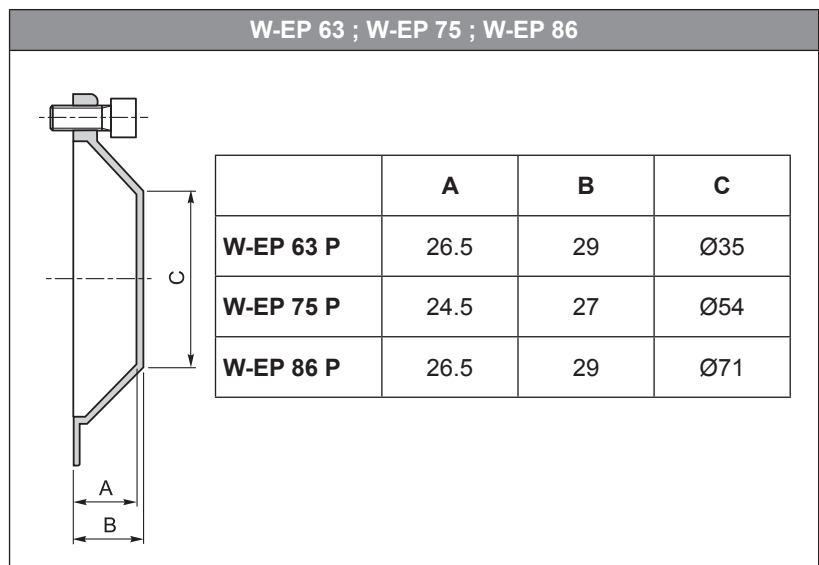
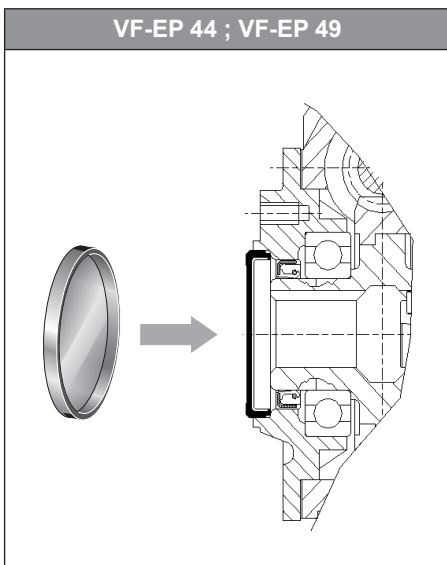

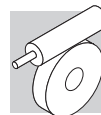

ENDSCHALTER-VORRICHTUNG RVS

39 ALLGEMEINE INFORMATIONEN

Die Endschalter-Vorrichtung Typ RVS wurde entwickelt, um die Getriebemotoren mit Schnecke von Bonfiglioli Riduttori bei der Betätigung von:

- Fenstern und Vorrichtungen zur Schattenerzeugung für Treibhäuser
- automatischen Toren
- Klappfenstern
- Dosieranlagen für Getreide im Zootechnik-Sektor
- Drosselventilen zu vervollständigen und an diese anzupassen.

Die mit der Vorrichtung RVS ausgestatteten Getriebemotoren sind auch für alle anderen Schritt-Anwendungen geeignet, bei denen eine kontrollierte und genaue Bewegung erforderlich ist.

Für die oben beschriebenen Anwendungen, die durch einen leichten Schritt-Service charakterisiert sind, empfiehlt es sich, die Wahl der Übertragungsgruppen ausschließlich, wie auf den Seiten des Paragraphen 40 angegeben, durchzuführen. Die so durchgeführten Wahlen sind konform zu dem bestimmten Servicetyp und zu den Höchstgeschwindigkeiten, die mit dem regulären Betrieb der Endschalter-Vorrichtung verträglich sind.

Die vollständige Konfiguration wird durch die Montage der Endschalter-Vorrichtung auf das entsprechende Motorgetriebe mittels des spezifischen (auch für die Gruppen Typ VF 49, W63, W75 und W86 verfügbaren), auf der folgenden Seite gezeigten Montage-Sets erhalten.

Für die Montage der Vorrichtung **RVS** müssen die Getriebemotoren in der geflanschten Herstellungsform sein.

39.1 Technische eigenschaften

Der Betrieb der Endschalter-Vorrichtung gründet auf einer Differentialbewegung von zwei mit Nocken ausgestatteten Räderpaaren und auf die entsprechende Betätigung der Präzisions-Mikroschalter, die durch Relais (vom Installateur eingebaut) den Bewegungsstopp und die Bewegungsumkehr steuern. Die Extrem-Positionen der Bewegung, die Öffnung und das Schließen des Rahmens, können leicht mit dem bereits installierten Getriebemotor und ohne Verwendung von spezifischen Ausrüstungen, sondern nur mit einem herkömmlichen Inbusschlüssel eingestellt werden.

Ist die gewünschte Einstellung erreicht und fixiert, wird diese in der Zeit konstant gehalten, wodurch die Betätigungen oft wiederholt werden können. In der Grundausführung wird die Endschalter-Gruppe **RVS** mit einem innen vorverkabelten und ungefähr ein Meter langen Kabelpaar geliefert.

Die Gruppe ist außerdem in folgenden Varianten erhältlich:

RVS ME: ist mit einem äußeren Klemmenkasten mit sechs End-verschlüssen ausgestattet, an die die Verbindungskabel mit den Relais angeschlossen werden.

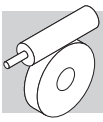

RVS DM: ist mit einer doppelten, serienverbundenen Mikroschalter-Serie für eine vollkommene Ein-griffsicherheit und entsprechend der Normen ausgestattet, die die Redundanz dieser Vorrichtung vorsehen.



RVS ME DM: mit einer äußeren und doppelten Mikroschalter-Serie, wie oben beschrieben, ausgestattete Vorrichtung.

Alle Varianten der Endschalter-Vorrichtungen sind wie folgt charakterisiert:



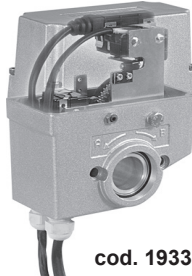
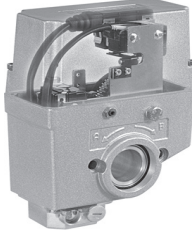

- äußerst leise
- gemäßiger Raumbedarf
- leicht zu installieren und einzustellen
- mit Gesamtschutz IP55 ausgestattet
- innerhalb eines Höchstbereichs von 43 Umdrehungen der Abtriebswelle einstellbar

40 ART.-NR. FÜR DIE BESTELLUNG

Die für die Anwendung notwendige Vorrichtung oder ihre Variante bestimmen und dabei auf die unterstehende Tabelle für die entsprechende Art.-Nr. für die Bestellung Bezug nehmen.

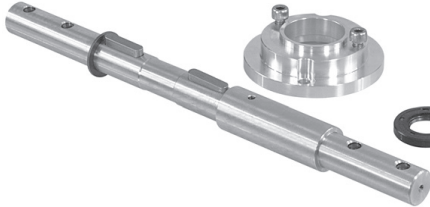
RVS	RVS ME	RVS DM	RVS ME DM
 cod. 193312025	 cod. 193312026	 cod. 193312027	 cod. 193312028

Außerdem die entsprechende Art.-Nr. des Konfigurations-Sets für das Getriebe auswählen, auf das die Endschalter-Vorrichtung installiert werden soll.

 cod. 192860001	 cod. 192860002	 cod. 192860003	 cod. 192860004
---	---	--	--

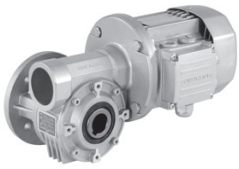
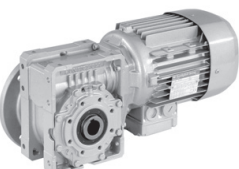
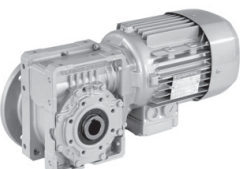
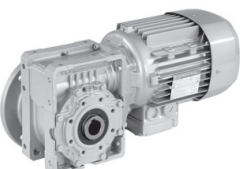
 VF 49 F - VFR 49 F	 W 63 UFC - WR 63 UFC	 W 75 UFC - WR 75 UFC	 W 86 UFC - WR 86 UFC
---	---	--	---

41 BEZEICHNUNG

Einsatz der **VF** und **W** für Passung an Anlaufvorrichtung.

W R 75 UFC1 D30 240 P71 B5 B3

OPTIONEN
EINBAULAGEN
B3 (default), **B6, B7, B8, V5, V6**

MOTORFLANSCH IEC
B5
B14

BEZEICHNUNG DER ANTRIEBSSEITE
VF: **P** (IEC)
W: **S_, P** (IEC)

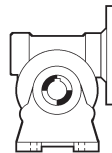

P63, P71



BN - BE
BX - BXN

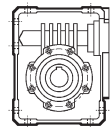

S1 ... S3
S10 ... S20

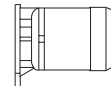

M - ME -
MX - MXN

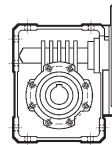

P63 ... P90



BN - BE
BX - BXN

ÜBERSETZUNG

ABTRIEBSWELLEDURCHMESSER
D30 (nür für W75)

BAUFORM
VF: **F**
W: **UFC**

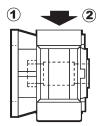

F (1, 2)

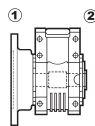

UFC (1, 2)

BAUGRÖSSE
VF: **49**
W: **63, 75, 86**

VORSTUFE
R

GETRIEBE TYP

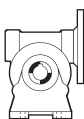

VF

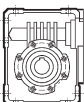

W

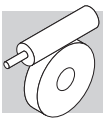
**42 GETRIEBEMOTOREN-AUSWAHLTABELLEN****0.12 kW**

n ₂ min ⁻¹	M ₂ Nm	i			IEC					
					IE1	IE2	IE3	IE1	IE2	IE3
4.7	98	300	VFR 49_300	P63	BN63A4	BE63A4	BXN63MA4			
5.8	89	240	VFR 49_240	P63	BN63A4	BE63A4	BXN63MA4			
6.7	83	210	VFR 49_210	P63	BN63A4	BE63A4	BXN63MA4			
7.8	76	180	VFR 49_180	P63	BN63A4	BE63A4	BXN63MA4			
10.4	64	135	VFR 49_135	P63	BN63A4	BE63A4	BXN63MA4			
14.0	41	100	VF 49_100	P63	BN63A4	BE63A4	BXN63MA4			
17.5	37	80	VF 49_80	P63	BN63A4	BE63A4	BXN63MA4			
20.0	34	70	VF 49_70	P63	BN63A4	BE63A4	BXN63MA4			
23.3	31	60	VF 49_60	P63	BN63A4	BE63A4	BXN63MA4			

0.18 kW

n ₂ min ⁻¹	M ₂ Nm	i			IEC					
					IE1	IE2	IE3	IE1	IE2	IE3
7.8	112	180	VFR 49_180	P63	BN63B4	BE63B4	BXN63MB4			
10.4	95	135	VFR 49_135	P63	BN63B4	BE63B4	BXN63MB4			
14.0	61	100	VF 49_100	P63	BN63B4	BE63B4	BXN63MB4			
17.5	54	80	VF 49_80	P63	BN63B4	BE63B4	BXN63MB4			
20.0	49	70	VF 49_70	P63	BN63B4	BE63B4	BXN63MB4			
23.3	45	60	VF 49_60	P63	BN63B4	BE63B4	BXN63MB4			

0.25 kW

n ₂ min ⁻¹	M ₂ Nm	i			IEC					
					IE1	IE2	IE3	IE1	IE2	IE3
4.7	214	300	WR 63_300	P71	BN71A4	BE71A4	BXN71MA4			
5.8	192	240	WR 63_240	P71	BN71A4	BE71A4	BXN71MA4			
7.3	170	192	WR 63_192	P71	BN71A4	BE71A4	BXN71MA4			
10.4	136	135	WR 63_135	P71	BN71A4	BE71A4	BXN71MA4			
12.3	121	114	WR 63_114	P71	BN71A4	BE71A4	BXN71MA4			
14.0	82	100	VF 49_100	P71	BN71A4	BE71A4	BXN71MA4			
17.5	72	80	VF 49_80	P71	BN71A4	BE71A4	BXN71MA4			
20.0	66	70	VF 49_70	P71	BN71A4	BE71A4	BXN71MA4			
23.3	61	60	VF 49_60	P71	BN71A4	BE71A4	BXN71MA4			

0.37 kW

n ₂ min ⁻¹	M ₂ Nm	i			IEC					
					IE1	IE2	IE3	IE1	IE2	IE3
4.7	382	300	WR 86_300	P71	BN71B4	BE71B4	BXN71MB4			
5.8	306	240	WR 75_240	P71	BN71B4	BE71B4	BXN71MB4			
7.3	290	192	WR 86_192	P71	BN71B4	BE71B4	BXN71MB4			
7.8	257	180	WR 75_180	P71	BN71B4	BE71B4	BXN71MB4			
9.3	226	150	WR 75_150	P71	BN71B4	BE71B4	BXN71MB4			
10.4	204	135	WR 63_135	P71	BN71B4	BE71B4	BXN71MB4			
12.3	181	114	WR 63_114	P71	BN71B4	BE71B4	BXN71MB4			
14.0	133	100	W 63_100	P71	BN71B4	BE71B4	BXN71MB4	S1 M1SD4	S1 ME1SB4	S10 MXN10MB4
17.5	108	80	VF 49_80	P71	BN71B4	BE71B4	BXN71MB4			
20.0	98.3	70	VF 49_70	P71	BN71B4	BE71B4	BXN71MB4			
23.3	90.5	60	VF 49_60	P71	BN71B4	BE71B4	BXN71MB4			

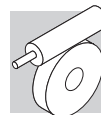

0.55 kW

n ₂ min ⁻¹	M ₂ Nm	i			IEC					
					IE1	IE2	IE3	IE1	IE2	IE3
4.7	559	300	WR 86_300	P80	BN80A4	BE80A4	BXN80MA4			
5.8	483	240	WR 86_240	P80	BN80A4	BE80A4	BXN80MA4			
7.3	423	192	WR 86_192	P80	BN80A4	BE80A4	BXN80MA4			
7.8	376	180	WR 75_180	P80	BN80A4	BE80A4	BXN80MA4			
8.3	383	168	WR 86_168	P80	BN80A4	BE80A4	BXN80MA4			
9.3	331	150	WR 75_150	P80	BN80A4	BE80A4	BXN80MA4			
10.1	330	138	WR 86_138	P80	BN80A4	BE80A4	BXN80MA4			
11.7	287	120	WR 75_120	P80	BN80A4	BE80A4	BXN80MA4			
14.0	194	100	W 63_100	P80	BN80A4	BE80A4	BXN80MA4	S1 M1LA4	S2 ME2SA4	S20 MXN20MA4
17.5	170	80	W 63_80	P80	BN80A4	BE80A4	BXN80MA4	S1 M1LA4	S2 ME2SA4	S20 MXN20MA4
21.9	148	64	W 63_64	P80	BN80A4	BE80A4	BXN80MA4	S1 M1LA4	S2 ME2SA4	S20 MXN20MA4
23.3	148	60	W 75_60	P80	BN80A4	BE80A4	BXN80MA4	S1 M1LA4	S2 ME2SA4	S20 MXN20MA4

0.75 kW

n ₂ min ⁻¹	M ₂ Nm	i			IEC					
					IE2	IE3	IE3	IE2	IE3	IE3
7.4	557	192	WR 86_192	P80	BE80B4	BX90SR4	BXN80MB4			
8.5	504	168	WR 86_168	P80	BE80B4	BX90SR4	BXN80MB4			
9.5	435	150	WR 75_150	P80	BE80B4	BX90SR4	BXN80MB4			
10.3	436	138	WR 86_138	P80	BE80B4	BX90SR4	BXN80MB4			
11.9	378	120	WR 75_120	P80	BE80B4	BX90SR4	BXN80MB4			
14.3	275	100	W 75_100	P80	BE80B4	BX90SR4	BXN80MB4	S2 ME2SB4	S2 MX2SB4	S20 MXN20MB4
17.9	236	80	W 75_80	P80	BE80B4	BX90SR4	BXN80MB4	S2 ME2SB4	S2 MX2SB4	S20 MXN20MB4
22.3	195	64	W 63_64	P80	BE80B4	BX90SR4	BXN80MB4	S2 ME2SB4	S2 MX2SB4	S20 MXN20MB4
23.8	196	60	W 75_60	P80	BE80B4	BX90SR4	BXN80MB4	S2 ME2SB4	S2 MX2SB4	S20 MXN20MB4

1.1 kW

n ₂ min ⁻¹	M ₂ Nm	i			IEC					
					IE2	IE3	IE3	IE2	IE3	IE3
10.4	643	138	WR 86_138	P90	BE90S4	BX90S4	BXN90S4			
11.9	586	120	WR 86_120	P90	BE90S4	BX90S4	BXN90S4			
14.3	437	100	W 86_100	P90	BE90S4	BX90S4	BXN90S4	S3 ME2SA4	S3 MX3SA4	
17.9	379	80	W 86_80	P90	BE90S4	BX90S4	BXN90S4	S3 ME3SA4	S3 MX3SA4	
22.3	322	64	W 86_64	P90	BE90S4	BX90S4	BXN90S4	S3 ME3SA4	S3 MX3SA4	

1.5 kW

n ₂ min ⁻¹	M ₂ Nm	i			IEC					
					IE2	IE3	IE3	IE2	IE3	IE3
11.9	792	120	WR 86_120	P90		BX90LA4				
17.9	512	80	W 86_80	P90		BX90LA4			S3 MX3SB4	
22.3	435	64	W 86_64	P90		BX90LA4			S3 MX3SB4	

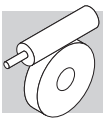

VF 49_F - VFR 49_F

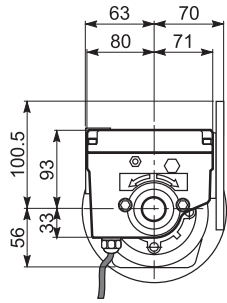

VF 49_F

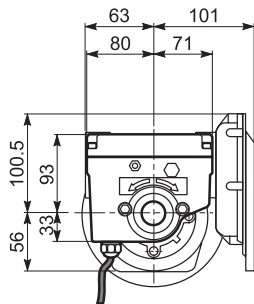
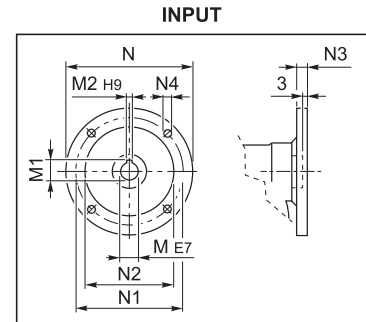
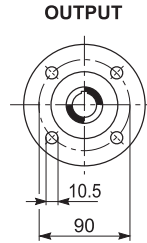
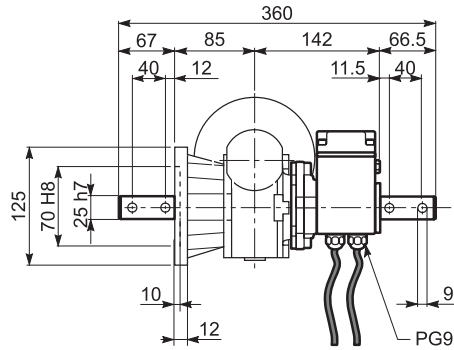

VFR 49_F

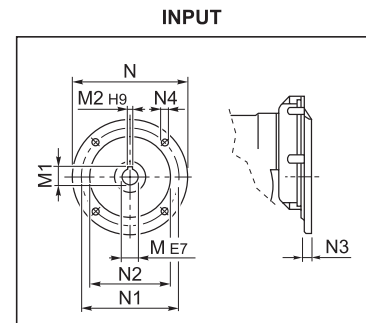
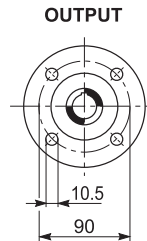
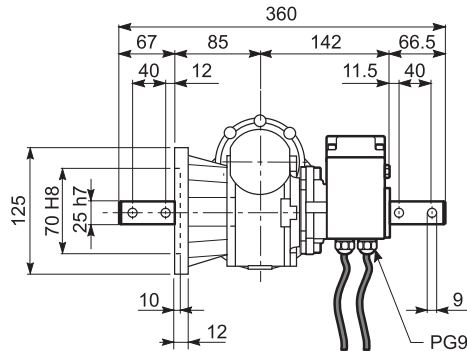

	M	M1	M2	N	N1	N2	N3	N4
VF 49_P 63	11	12.8	4	140	115	95	10.5	9.5
VF 49_P 71	14	16.3	5	160	130	110	10.5	9.5
VFR 49_P 63	11	12.8	4	140	115	95	11	M8x19

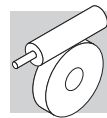

W 63 UFC_M/ME - W 63 UFC - WR 63 UFC

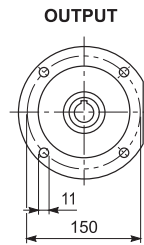
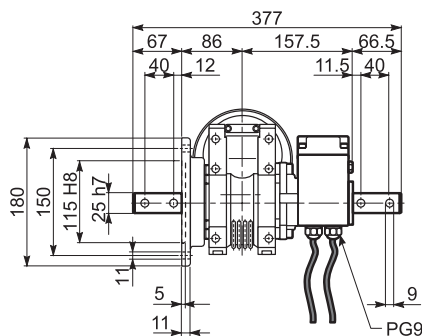
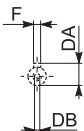
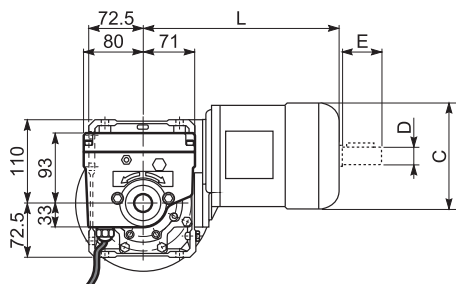

W 63 UFC_M/ME

	C	D	DA	DB	E	F	L
W 63_S1 M1L	138	14	16	M5	30	5	289
W 63_S2 ME2S	156	19	21.5	M6	40	6	317

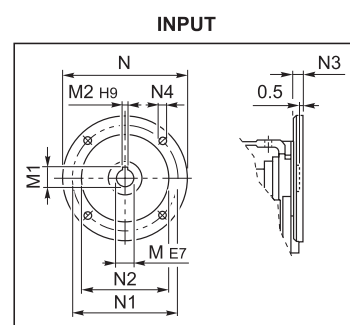
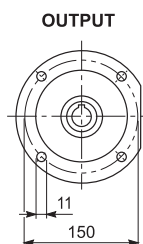
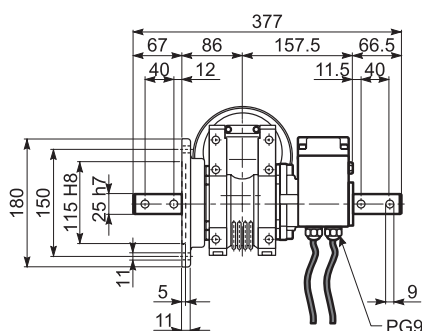
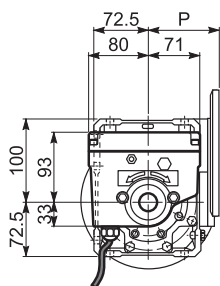

W 63 UFC

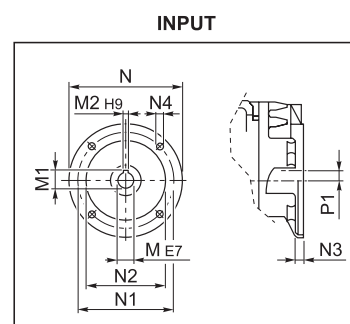
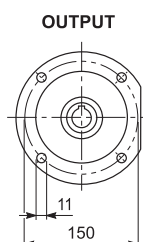
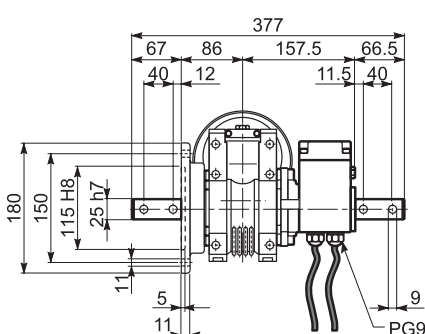
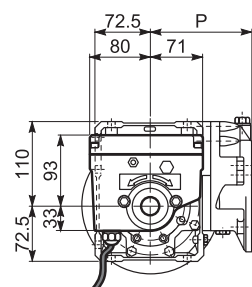

WR 63 UFC

	M	M1	M2	N	N1	N2	N3	N4	P	P1
W 63_P 71	14	16.3	5	160	130	110	11	9	95	-
W 63_P 80	19	21.8	6	200	165	130	12	11.5	102	-
W 63_P 90	24	27.3	8	200	165	130	12	11.5	102	-
WR 63_P 63	11	12.8	4	140	115	95	10	M8x10	133.5	11.42
WR 63_P 71	14	16.3	5	160	130	110	10	M8x10	133.5	11.42

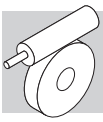

W 75 UFC_M/ME - W 75 UFC - WR 75 UFC

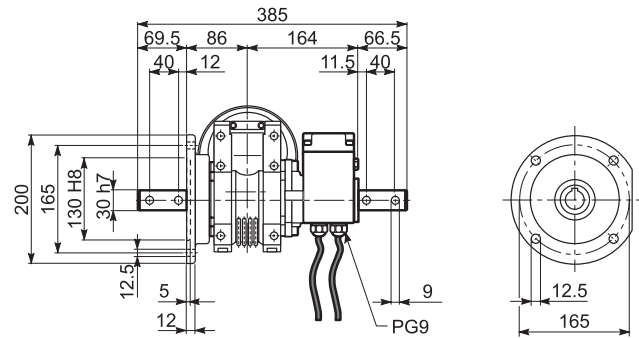
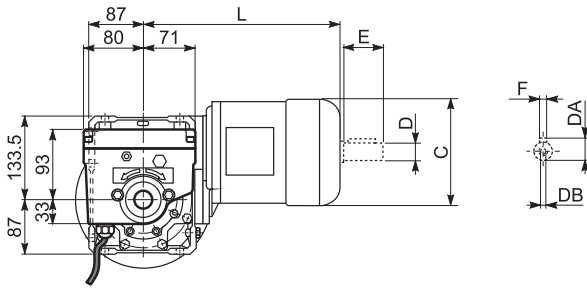

W 75 UFC_M/ME

	C	D	DA	DB	E	F	L
W 75_S1 M1L	138	14	16	M5	30	5	308
W 75_S2 ME2S	156	19	21.5	M6	40	6	333
W 75_S3 ME3S	193	28	31	M10	60	8	376
W 75_S3 ME3L	193	28	31	M10	60	8	408

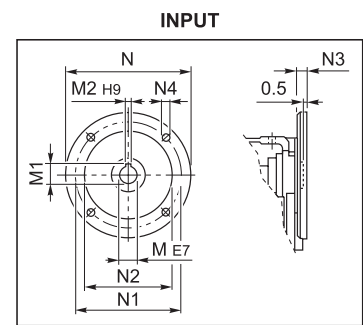
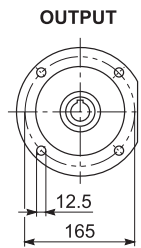
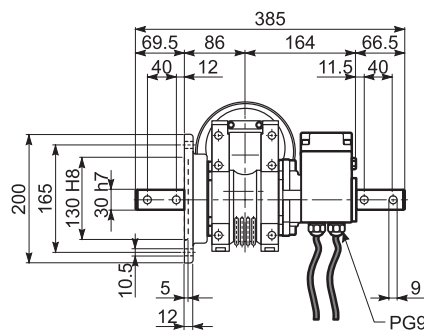
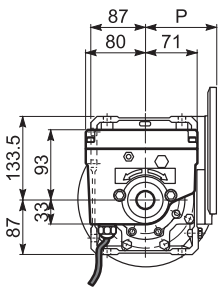

W 75 UFC

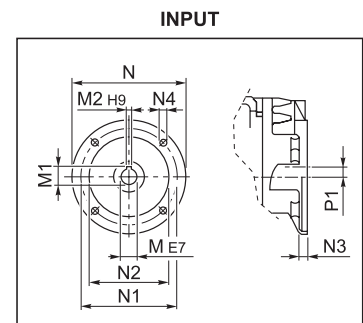
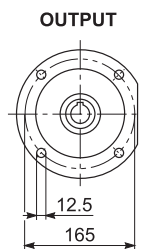
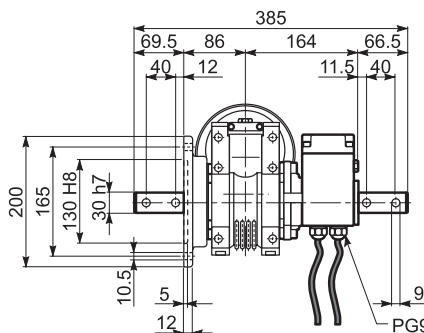
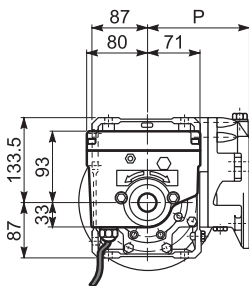

WR 75 UFC

	M	M1	M2	N	N1	N2	N3	N4	P	P1
W 75_P 71	14	16.3	5	160	130	110	11	9	112	-
W 75_P 80	19	21.8	6	200	165	130	12	11.5	112	-
W 75_P 90	24	27.3	8	200	165	130	12	11.5	112	-
WR 75_P 63	11	12.8	4	140	115	95	10	M8x10	152	23.53
WR 75_P 71	14	16.3	5	160	130	110	10	M8x10	152	23.53
WR 75_P 80	19	21.8	6	200	165	130	12	M10x13	163.5	11
WR 75_P 90	24	27.3	8	200	165	130	12	M10x13	163.5	11

W 86 UFC_M/ME - W 86 UFC - WR 86 UFC

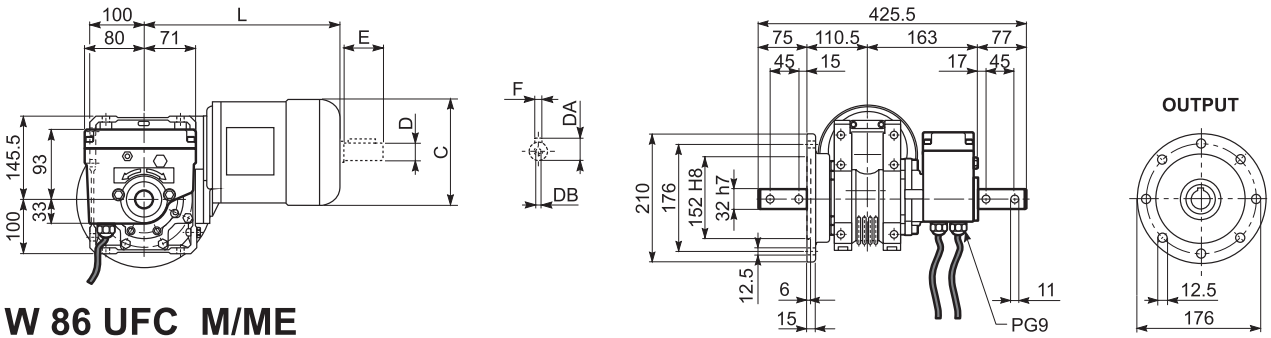

W 86 UFC_M/ME

	C	D	DA	DB	E	F	L
W 86_S1 M1L	138	14	16	M5	30	5	324
W 86_S2 ME2S	156	19	21.5	M6	40	6	349
W 86_S3 ME3S	193	28	31	M10	60	8	392
W 86_S3 ME3L	193	28	31	M10	60	8	424

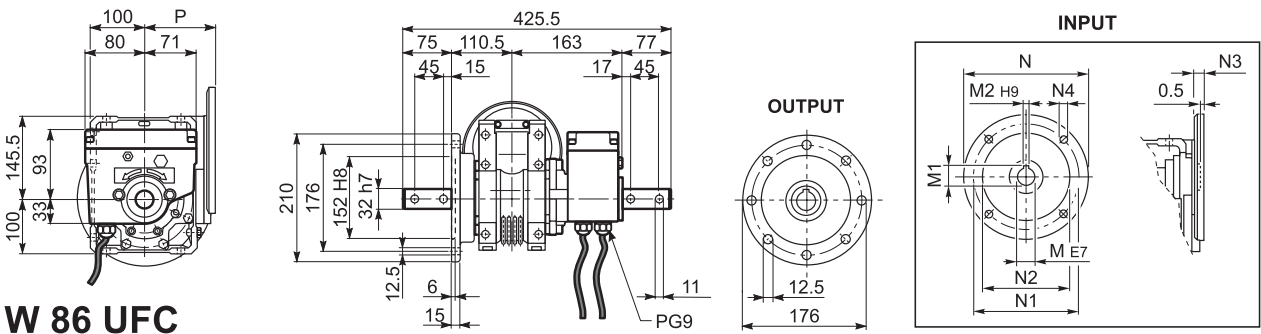

W 86 UFC

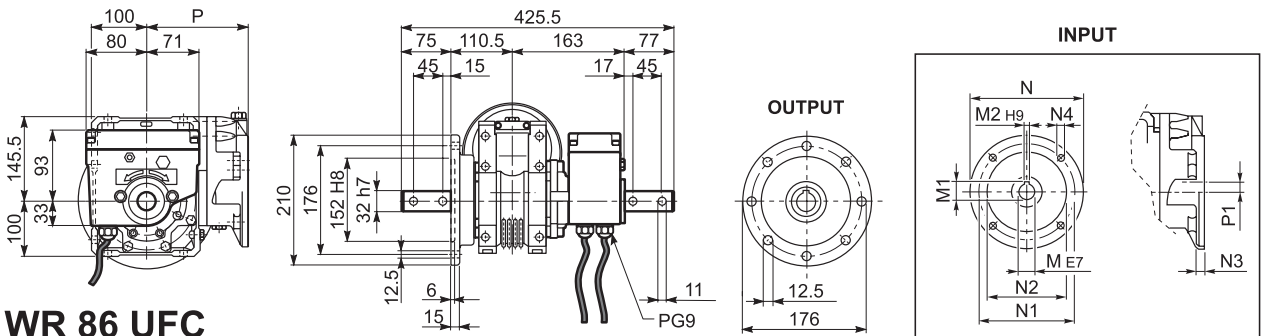

WR 86 UFC

	M	M1	M2	N	N1	N2	N3	N4	P	P1
W 86_P 71	14	16.3	5	160	130	110	11	9	128	-
W 86_P 80	19	21.8	6	200	165	130	12	11.5	128	-
W 86_P 90	24	27.3	8	200	165	130	12	11.5	128	-
WR 86_P 63	11	12.8	4	140	115	95	10	M8x10	168	35.4
WR 86_P 71	14	16.3	5	160	130	110	10	M8x10	168	35.4
WR 86_P 80	19	21.8	6	200	165	130	12	M10x13	179.5	22.9
WR 86_P 90	24	27.3	8	200	165	130	12	M10x13	179.5	22.9

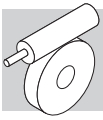

44 OPTIONEN

Endschalter-Varianten

ME

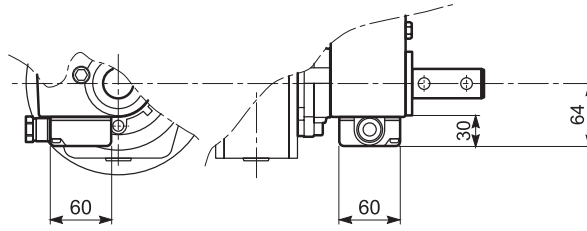

Version mit Klemmenkasten

DM

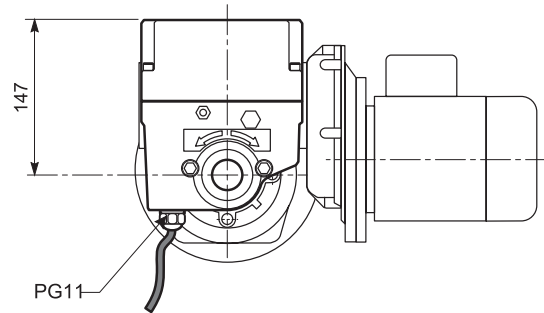

Version mit vier Mikroschaltern

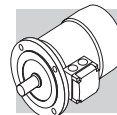

ELEKTROMOTOREN

M1 SYMBOLE UND MAßEINHEITEN

Symbole	Maßeinheiten	Beschreibung	Symbole	Maßeinheiten	Beschreibung
$\cos\varphi$	–	Leistungsfaktor	n	[min ⁻¹]	Nenn Drehzahl
η	–	Wirkungsgrad	P_B	[W]	Leistungsaufnahme der Bremse bei 20°C
f_m	–	Leistungsfaktorkorrektur	P_n	[kW]	Nennleistung
I	–	Relative Einschaltdauer	P_r	[kW]	Benötigte Leistung
I_N	[A]	Nennstrom	t_1	[ms]	Ansprechzeit Bremse mit Einweg-Gleichrichter
I_S	[A]	Kurzschlussstrom	t_{1s}	[ms]	Ansprechzeit Bremse mit elektronisch gesteuertem Gleichrichter
J_C	[Kgm ²]	Massenträgheitsmoment der Last	t_2	[ms]	Einfallzeit Bremse bei Unterbrechung der Stromversorgung WS
J_M	[Kgm ²]	Massenträgheitsmoment	t_{2c}	[ms]	Einfallzeit Bremse bei Unterbrechung der Stromversorgung WS und GS
K_C	–	Drehmomentfaktor	t_a	[°C]	Umgebungstemperatur
K_d	–	Lastfaktor	t_f	[min]	Betriebsdauer bei gleicher Belastung
K_J	–	Trägheitsmomentfaktor	t_r	[min]	Aussetzzeit
M_A	[Nm]	Mittleres Beschleunigungsmoment	W	[J]	Bremsenergieaufnahme zwischen zwei Nachstellungen
M_B	[Nm]	Bremsmoment	W_{max}	[J]	Max. Bremsarbeit pro Bremsvorgang
M_N	[Nm]	Nennmoment	Z	[1/h]	Schalhäufigkeit unter Last
M_L	[Nm]	Mittleres Gegenmoment	Z_0	[1/h]	Max. Schalhäufigkeit im Leerlauf (relative Einschalt-dauer I = 50%)
M_S	[Nm]	Startmoment			



M2 EINFÜHRUNG

Wirkungsgradklassen und Prüfverfahren

Die Wirkungsgradklassen beschreiben die Effizienz, mit der ein Elektromotor elektrische in mechanische Energie umwandelt. In Europa erfolgte die Energieklassifizierung von Niederspannungsmotoren auf freiwilliger Basis unter Bezugnahme auf die Klassen Eff1/Eff2/Eff3. Andere Länder benutzten eigene nationale Klassifizierungssysteme, die oftmals vom europäischen System abwichen. Diese normative Unsicherheit hat die Hersteller dazu bewogen, eine internationale Harmonisierung anzustreben, die zur Ausgabe der IEC-Norm (International Electrotechnical Commission) IEC 60034-30-1, "Wirkungsgradklassen für eintourige Drehstrom-Käfigläufer-Asynchronmotoren (IE-Code)" führte.

Die neue Norm:

- definiert die neuen Wirkungsgradklassen;

IE1 (Standard-Wirkungsgrad)

IE2 (hoher Wirkungsgrad)

IE3 (Premium-Wirkungsgrad)

- liefert einen gemeinsamen internationalen Bezug für die Klassifizierung von Elektromotoren wie auch für die gesetzgebenden Aktivitäten der Länder;

- führt ein neues Messverfahren des Wirkungsgrads in Übereinstimmung mit der Norm IEC 60034-1-2:2007 ein.

In der nachfolgenden Tabelle ist die Entsprechung zwischen den wesentlichen Klassifikationen aufgeführt.

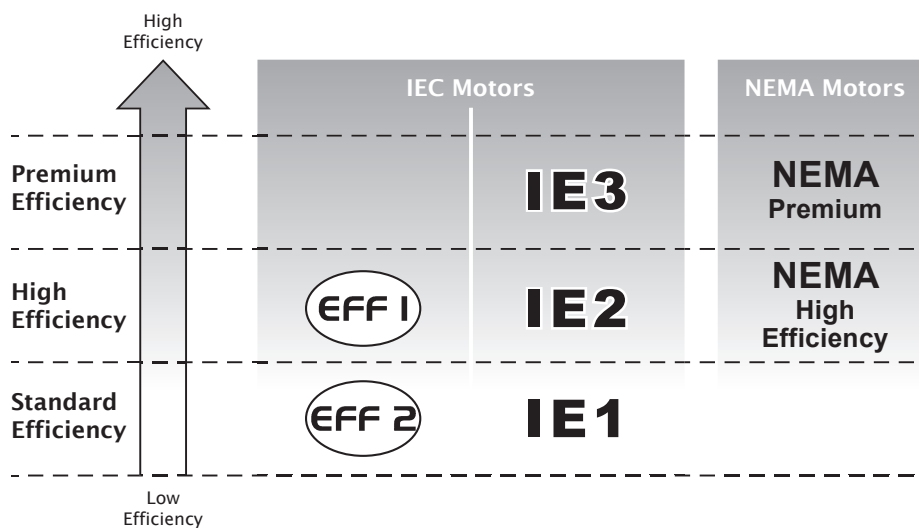

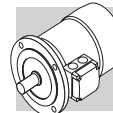

EG Verordnung Nr. 640/2009

Die Norm IEC 60034-30-1 liefert die technischen Leitlinien, bestimmt aber nicht die gesetzlichen Vorgaben bezüglich der Anforderungen für die Anwendung einer bestimmten Wirkungsgradklasse. Diese Anforderungen sind durch die Richtlinien und nationalen Gesetze spezifiziert. Die Verordnung vom 22. Juli 2009 zur Durchführung der Richtlinie 2005/32/EG legt diese Anforderungen fest, spezifiziert die Kriterien für die umweltgerechte Gestaltung der Elektromotoren und bestimmt das Wirkungsgradniveau nach folgendem Zeitplan:

- **16.06.2011:** Die Elektromotoren müssen mindestens der Wirkungsgradklasse **IE2** entsprechen
- **01.01.2015:** Die Elektromotoren mit einer Nennausgangsleistung zwischen 7.5 kW und 375 kW müssen mindestens der Wirkungsgradklasse **IE3** entsprechen, oder der Klasse **IE2**, wenn diese über einen Frequenzumrichter angesteuert werden.
- **01.01.2017:** Die Elektromotoren mit einer Nennausgangsleistung zwischen 0.75 kW und 375 kW müssen mindestens der Wirkungsgradklasse **IE3** entsprechen, oder der Klasse **IE2**, wenn diese über einen Frequenzumrichter angesteuert werden.

Geltungsbereich und Ausnahmen

Die Verordnung (EG) Nr. 640/2009 gilt für eintourige 2-, 4- bzw. 6-polige Dreiphasen 50 oder 60 Hz Käfigläufer-Induktionsmotoren mit Nennausgangsleistungen zwischen 0,75 kW und 375 kW, einer Nennspannung bis 1000 V und der Auslegung für Dauerbetrieb (S1).

Diese Verordnung gilt nicht für:

- Bremsmotoren.
- Motoren, die dafür ausgelegt sind, ganz in eine Flüssigkeit eingetaucht betrieben zu werden.
- vollständig in ein Produkt (z.B. Getriebe, Pumpen, Ventilatoren) eingebaute Motoren, deren Energieeffizienz nicht unabhängig von diesem Produkt erfasst werden kann.
- Motoren, die speziell für den Betrieb unter folgenden Bedingungen ausgelegt sind:
 - in Höhen über 4000 Meter über dem Meeresspiegel;
 - bei Umgebungstemperaturen über 60 °C;
 - bei Betriebshöchsttemperaturen über 400 °C;
 - bei Umgebungstemperaturen unter -30 °C (beliebiger Motor) oder unter 0 °C (Wassergekühlte Motoren);
 - bei Kühlflüssigkeitstemperaturen am Einlass eines Produkts unter 0 °C oder über 32 °C;
 - in explosionsgefährdeten Bereichen im Sinne der Richtlinie 2014/34/EU.



M3 ALLGEMEINE EIGENSCHAFTEN

M3.1 Produktprogramm

Die Dreiphasen-Asynchronmotoren BXN, BX, BE, BN, MXN, MX, ME und M aus dem Produktprogramm von BONFIGLIOLI RIDUTTORI gibt es in den Grundbauform IMB5 und Ableitungen. Es handelt sich um Käfigläufermotoren mit Lüftern für industrielle Anwendungen. Die BX, BE, MX, ME Motoren sind in der Standardausführung für die Nennspannungen 230/400V Δ/Y (400/690V Δ/Y für die Größen von BX/BE 160 und BX/BE 180) 50 Hz, mit einer Toleranz von $\pm 10\%$ vorgesehen. Die BN/M Motoren sind in der Standardausführung für eine Nennspannung von 230/400V Δ/Y (400/690V Δ/Y für die Größen von BE 160 ... BE 200) 50 Hz, mit einer Toleranz von $\pm 10\%$ vorgesehen. Bei den BXN/MXN-Motoren ist standardmäßig ein Klemmenkasten mit 9-poligem Anschluss + 12-Draht-Wicklung vorhanden, der es einfach macht, die richtige Spannung für die meisten Länder zu erhalten. Die Standardversionen sind als WD1 gekennzeichnet und ermöglichen die folgenden Spannungen/Frequenzen (115/200/230/400 V-50 Hz und 132/230/265/460 V-60 Hz). Bei den BXN/MXN-Motoren ist die Spannungstoleranz auf $\pm N175\%$ reduziert.

M3.2 Normen

Die in diesem Katalog beschriebenen Motoren sind in Übereinstimmung mit den in der folgenden Tabelle angegebenen einschlägigen Normen und Vereinheitlichungsrichtlinien konstruiert worden.

(F01)	Titel	CEI	IEC
	Allgemeine Vorschriften für drehende elektrische Maschinen	CEI EN 60034-1	IEC 60034-1
	Anschlussbezeichnungen und Drehrichtung von drehenden elektrischen Maschinen	CEI 2-8	IEC 60034-8
	Verfahren zur Kühlung von elektrischen Maschinen	CEI EN 60034-6	IEC 60034-6
	Standardisierte Abmessungen und Leistungen von drehenden elektrischen Maschinen	EN 50347	IEC 60072
	Klassifizierung der Schutzart von drehenden elektrischen Maschinen	CEI EN 60034-5	IEC 60034-5
	Geräuschgrenzwerte	CEI EN 60034-9	IEC 60034-9
	Kennzeichnung der Bauformen, Aufstellung und Klemmkastenlage	CEI EN 60034-7	IEC 60034-7
	IEC Normspannungen	CEI 8-6	IEC 60038
	Mechanische Schwingungen (Verfahren und Grenzwerte) für elektrischen Maschinen	CEI EN 60034-14	IEC 60034-14
	Wirkungsgradklassen der eintourigen Drehstrom-Asynchronmotoren mit Käfigläufer (IE-Code)	CEI EN 60034-30-1	IEC 60034-30-1
	Genormte Testverfahren zur Bestimmung der Verluste und des Wirkungsgrads	CEI EN 60034-2-1	IEC 60034-2-1

Die Motoren entsprechen außerdem den an die IEC-Norm 60034-1 angepassten ausländischen Normen, die in der folgenden Tabelle genannt werden.

(F02)	DIN VDE 0530	Deutschland
	BS5000 / BS4999	Großbritannien
	AS 1359	Australien
	NBNC 51 - 101	Belgien
	NEK - IEC 34	Norwegen
	NF C 51	Frankreich
	OEVE M 10	Österreich
	SEV 3009	Schweiz
	NEN 3173	Niederlande
	SS 426 01 01	Schweden



M3.3 Richtlinien 2006/95/EG (LVD) und 2004/108/EG (EMC)

BXN-, BX-, BE-, BN-, MXN-, MX-, ME- und M-Motoren erfüllen die Anforderungen der Richtlinien 2014/35/UE (LVD - Niederspannungsrichtlinie), der 2014/30/UE (EMV - Richtlinie zur elektromagnetischen Verträglichkeit), der 2009 /125/CE (ERP – Energy Related Products Directive) und 2011/65/UE (RoHS – Restriction of Hazardous Substances) und deren Typenschilder tragen das CE-Zeichen. Bezüglich der EMV-Richtlinie entspricht die Konstruktion den Normen CEI EN 60034-1 (Rotierende elektrische Maschinen Teil 1: Bewertung und Leistung), CEI EN 61000-6-2 (Allgemeine Normen – Störfestigkeit für industrielle Umgebungen), CEI EN 61000- 6-4 (Fachgrundnormen – Emissionsnorm für industrielle Umgebungen).

Motoren mit FD-Bremsen erfüllen, wenn sie mit dem geeigneten kapazitiven Filter am Gleichrichter-eingang (Option CF) ausgestattet sind, die von den Normen CEI EN 61000-6-3 und CEI EN 60204-1 geforderten Emissionsgrenzwerte.

Die Verantwortung für die Sicherheit des Endprodukts und die Einhaltung der geltenden Richtlinien liegt bei der

Hersteller oder der Monteur, der die Motoren als Einzelteile einbaut.

UKCA-Zeichen als Standard In Großbritannien wird das CE-Zeichen aufgrund des Brexit ab dem 1. Januar 2022 durch das UKCA-Zeichen (United Kingdom Conformity Assessed Mark) ersetzt. Alle Bonfiglioli-Motoren erfüllen bereits die UKCA-Anforderungen.

M3.4 EU-Richtlinie 2012/19 / EU - Informationen zur Entsorgung



Dieses Produkt darf nicht zusammen mit dem normalen Hausmüll entsorgt werden. Die Entsorgung muss gemäß der EU-Richtlinie 2012/19 / EU (sofern vorhanden) und gemäß den nationalen Vorschriften durchgeführt werden.

Die Entsorgung muss gemäß anderer geltender gesetzlicher Vorschriften im Land erfolgen.

M3.5 Toleranzen

Die Normen CEI EN 60034-1, lassen die in der nachfolgenden Tabelle genannten Toleranzen für die angegebenen Nennwerte zu:

(F03)	$-0.15 (1 - \eta) \quad P \leq 50\text{kW}$	Wirkungsgrad
	$-(1 - \cos\phi)/6 \quad \text{min } 0.02 \quad \text{max } 0.07$	Leistungsfaktor
	$\pm 20\% \quad *$	Schlupf
	+20%	Strom bei blockiertem Läufer
	-15% +25%	Drehmoment bei blockiertem Läufer
	-10%	Max. Drehmoment

(*) $\pm 30\%$ für Motoren mit $P_n < 1 \text{ kW}$

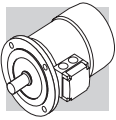

M4 MOTORBEZEICHNUNG

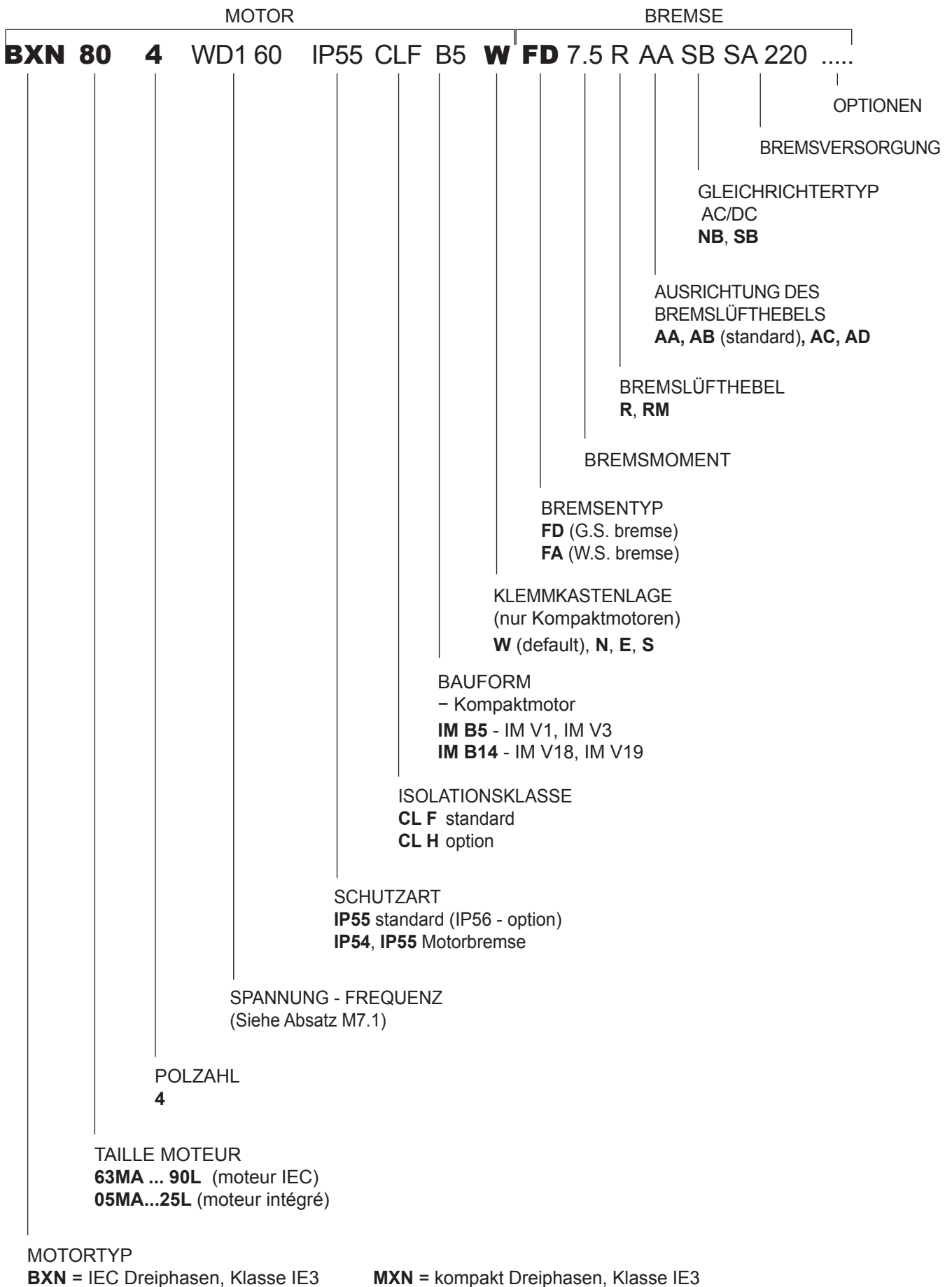

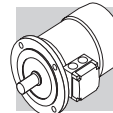

MOTOR

BREMSE

BX 132SB 4 230/400-50 IP55 CLF B5 **W FD** 7.5 R AA SB SA 220

OPTIONEN

BREMSVERSORGUNG

GLEICHRICHTERTYP
AC/DC
NB, SB, NBR, SBR

AUSRICHTUNG DES
BREMSLÜFTHEBELS
AA, AB (standard), **AC, AD**

BREMSLÜFTHEBEL
R, RM

BREMSMOMENT

BREMENTYP
FD (G.S. bremse)
FA (W.S. bremse)

KLEMMKASTENLAGE
(nur Kompaktmotoren)
W (default), **N, E, S**

BAUFORM
- Kompaktmotor
IM B5 - IM V1, IM V3
IM B14 - IM V18, IM V19

ISOLATIONSKLASSE
CL F standard
CL H option

SCHUTZART
IP55 standard (IP56 - option)
IP54, IP55 Motorbremse

SPANNUNG - FREQUENZ
(Siehe Absatz M7.1)

POLZAHL
4

MOTOR-BAUGRÖSSE
80B ... 355 (motor IEC)
2SB ... 5LA (Kompaktmotor)

MOTORTYP

BX = IEC Dreiphasen, Klasse IE3

MX = kompakt Dreiphasen, Klasse IE3

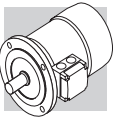

MOTOR

BREMSE

BE 90LA 4 230/400-50 IP55 CLF B5 W FD 7.5 R AA SB SA 220

OPTIONEN

BREMSVERSORGUNG

GLEICHRICHTERTYP
AC/DC
NB, SB, NBR, SBR

AUSRICHTUNG DES
BREMSLÜFTHEBELS
AA, AB (standard), **AC, AD**

BREMSLÜFTHEBEL
R, RM

BREMSMOMENT

BRESENTYP
FD (G.S. bremse)
FA (W.S. bremse)

KLEMMKASTENLAGE
(nur Kompaktmotoren)
W (default), **N, E, S**

BAUFORM
- Kompaktmotor
IM B5 - IM V1, IM V3
IM B14 - IM V18, IM V19

ISOLATIONSKLASSE
CL F standard
CL H option

SCHUTZART
IP55 standard (IP56 - option)
IP54, IP55 Motorbremse

SPANNUNG - FREQUENZ
(Siehe Absatz M7.1)

POLZAHL
2, 4, 6

MOTOR-BAUGRÖSSE
63A ... 180L (motor IEC)
05A ... 5L (Kompaktmotor)

TYPE MOTEUR

BE = IEC Dreiphasen, Klasse IE2

ME = kompakt Dreiphasen, Klasse IE2



MOTOR

BREMSE

BN 90LA 4 230/400-50 IP55 CLF B5 W FD 7.5 R AA SB SA 220

OPTIONEN

BREMSVERSORGUNG

GLEICHRICHTERTYP
AC/DC
NB, SB, NBR, SBR

AUSRICHTUNG DES
BREMSLÜFTHEBELS
AA, AB (standard), **AC, AD**

BREMSLÜFTHEBEL
R, RM

BREMSMOMENT

BREMENTYP
FD (G.S. bremse)
FA (W.S. bremse)

KLEMMKASTENLAGE
(nur Kompaktmotoren)
W (default), **N, E, S**

BAUFORM
– Kompaktmotor
IM B5 - IM V1, IM V3
IM B14 - IM V18, IM V19

ISOLATIONSKLASSE
CL F standard
CL H option

SCHUTZART
IP55 standard (IP56 - option)
IP54, IP55 Bremssmotor

SPANNUNG - FREQUENZ
(Siehe Absatz M7.1)

POLZAHL
2, 4, 6, 2/4, 2/6, 2/8, 2/12, 4/6, 4/8

MOTOR-BAUGRÖSSE
56A ... 200LA (motor IEC)
0B ... 5SB (Kompaktmotoren)

MOTORTYP

BN = IEC Dreiphasen **M** = kompakt Dreiphasen



M5 VARIANTEN UND OPTIONEN

M5.1 Varianten

(F04)

Descrizione		Default	Opzione	Pagina
Tensione (BN - BE - BX) ≤ 132		230/400/50		232
Tensione (BN - BE - BX) ≥ 160		400/690/50		
Tensione (BXN)		WD1		EVOX*
Grado di protezione	BXN - BX - BE - BN - MXN - MX - ME - M	IP 55	IP 56	228
	BXN - BX - BE - BN/FA-FD MXN - MX - ME - M/FA-FD	IP 54	IP 55	
	BX_FD ≥ 200	IP 55		
	BX...K - BX... K_FDK	IP 55	IP 56	
Classe di isolamento		CLF	CLH	239
Forma costruttiva	BX - BE - BN	B5 B5 R	B14 B14 R	227
	BXN	B5	B14	EVOX*

Valori pre-impostati di default. * Consultare lo specifico catalogo EVOX

M5.2 Optionen

(F05)

Beschreibung	Werte								Verfügbarkeit	Seite
Thermische Wicklungsschutz	D3	K1	E3	PT1000°°					BXN-BX-BE-BN-MXN-MX-ME-M	257-258
Auf 50 Hz genormte Leistung	PN								BN - M	235
Signalrückführungen (Drehgeber)	EN1	EN2	EN3	EN4	EN5	EN6	EN7*	EN8*	BXN-BX-BE-BN-MX-ME-M	267
Wicklungsheizung	H1	NH1							BXN-BX-BE-BN-MXN-MX-ME-M	261
Tropenschutz der Motorwicklungen	TP								BXN-BX-BE-BN-MXN-MX-ME-M	262
Zweites Wellenende	PS								BXN-BX-BE-BN-MXN-MX-ME-M	262
Rotorauswuchtung mit Grad B	RV								BX - BE - BN MX - ME - M	263
Schutzdächer	RC	TC***	EC°°						BXN-BX-BE-BN-MXN-MX-ME-M	265-268
Fremdlüfter	U1	U2**							BX - BE - BN MX - ME - M	264-265
Isolierte Lager	IB*								BX - MX	269
Zertifizierte Ausführung	CUS°								BXN-BX-BE-BN-MXN-MX-ME-M	236
Moteurs certifiés pour l'Inde	BIS								BE - ME	237
China Compulsory Certification	CCC								BX - BE - BN MX - ME - M	237
Für den Markt zertifizierte Motoren Chinesisch (chinesisches Energielabel)	CEL								BX - MX	237
Für den Markt zertifizierte Motoren Brasilianisch	NBR								BX - MX	238
Für den Markt zertifizierte Motoren australisch	EECA								BX - MX	238
Steckverbinder	CON								BX - BE - BN MX - ME - M	239
Oberflächenschutz	C_								BXN-BX-BE-BN-MXN-MX-ME-M	258
Lackierung	RAL								BXN-BX-BE-BN-MXN-MX-ME-M	269
Zertifikate	ACM								BXN-BX-BE-BN-MXN-MX-ME-M	270
Prüfzertifikat	CC								BXN-BX-BE-BN-MXN-MX-ME-M	270
Vertikale Montage	VM*								BX - MX	270
Rücklauf Sperre	AL	AR							MX - ME - M	263
Betriebsart	S2	S3	S9						BN - M	240
	S2-10	S2-30	S2-60	S3=25%	S3=40%	S3=70%			BXN - MXN	

* Nur für Motoren BX ≥ 280 und BX ≥ 280K ** Nur für Motoren BN *** Nur für Motoren BX - MX

° Standard für BXN/MXN, keine Option

°° Nur für Motoren BXN/MXN



M5.3 Bremsoptionen

(F06) Beschreibung	Werte				Verfügbarkeit	Seite
Bremsmoment	Bezogen auf speziellen Bremsentyp					249-252
Manueller Bremslufthebel	R	RM			BXN - BX - BE - BN MXN - MX - ME - M	255
Orientierung des Bremslösehebel	AB	AA	AC	AD	BXN - BX - BE - BN MXN - MX - ME - M	256
Stromversorgung der Bremse	NB	NBR°	SB	SBR°	BXN - BX - BE - BN MXN - MX - ME - M	248
Schwungrad für Sanftanlauf	F1				BE - BN ME - M	257
Kapazitiver Filter	CF				BXN - BX - BE - BN MXN - MX - ME - M	257
Separate Bremsversorgung (*)	...SA	...SD	DIR°°		BXN - BX - BE - BN MXN - MX - ME - M	256
Bremsenfunktionskontrolle	MSW				BX - BE - BN MX - ME - M	261
Zusätzliche Kabeldurchführung für Bremsmotoren	IC				BN M	261

(*) Spannungswert eintragen.

(°) Nicht für BXN/MXN

(°°) Nur für Motoren BXN/MXN - bedeutet „ohne separate Stromversorgung“

■ Standardwerte bei Lieferung falls nicht anders spezifiziert.

M5.4 Beispiel eines Identifikationstypenschilds für ältere Motoren (BX - BE - BN)

IEC EN 60034		Bonfiglioli Riduttori		CE	
3~Mot BE 90LA 4		Cod. 8U09030001			
No 1003001 - 6954785		S1 IM B5 15,1 kg			
kW 1,5		CL F IP 55 Amb 40 °C			
Hz	V ± 10%	A	min ⁻¹	cos φ	
50 ○	230/400 Δ/Y	6,1/3,5	1430	○ 0,74	
60	265/460 Δ/Y	5,4/3,1	1730	0,73	
50Hz-IE2		83.5(100%) - 83.0(75%) - 80.0(50%)			
60Hz-IE2		84.5(100%) - 83.9(75%) - 80.7(50%)			

① Identifikationscode
BONFIGLIOLI Motor

② Seriennummer

③ Nennspannung









④ Motor-Codenummer

⑤ Betriebsart: S1
Dauerbetrieb

⑥ Wirkungsgradklasse IE
bei: 4/4 - 3/4 - 2/4 Belastung



M5.4.1 Beispiel eines Typenschildes für EVOX-Motoren (BXN)

 				
3~Mot BXN 90L 4 FD TEFC IMB14 IP55 22,6 kg				
Cod. xxxxxxxxxxxx No xxxxxxxx - xxxxxxxx				
kW 1.5 HP 2 Amb 40 °C CLF S1				
Hz	V	A	min ⁻¹	cos φ
50	115/200 ΔΔ/YY	11.9/6.88	1441	0.75
50	230/400 Δ/Y	5.96/3.44	1441	0.75
60	132/230 ΔΔ/YY	10.1/5.84	1750	0.74
60	265/460 Δ/Y	5.6/2.92	1750	0.74
50Hz IE3 - 85.3 (100%) 84.3 (75%) 81.7 (50%) - KWA code J				
60Hz IE3 - 86.5 (100%) 86.5 (75%) 83.4 (50%) - KWA code L				
H1 1~ 230V ± 10% 10W				
VB = 230V MB = 26Nm NB SA				
				
				
CC320B		Bonfiglioli Riduttori S.p.A. Made in Italy		

- ① Motorbezeichnung und allgemeine Informationen
- ② Seriennummern
- ③ Umwelt- und Anwendungskonformität
- ④ Nennleistungen in Abhängigkeit von Spannungen/Frequenzen
- ⑤ Motorleistung bei 50 Hz
- ⑥ Motorleistung bei 60 Hz
- ⑦ Informationen zu Wärmeschutz und Kraftbelüftung
- ⑧ Informationen zur Bremse
- ⑨ Zertifizierungen
- ⑩ Angaben zum Hersteller



M6 MECHANISCHE EIGENSCHAFTEN

M6.1 Bauformen

Die Motoren der Serie BXN, BX, BE und BN weisen die in der nachstehenden Tabelle angegebene Bauform gemäß den Normen EN 60034-7 (BX/BE), CEI EN 60034-14 (BN). auf.

Die Bauformen sind:

IM B5 (Grundmodell)

IM V1, IM V3 (Ableitungen)

IM B14 (Grundmodell)

IM V18, IM V19 (Ableitungen)

Die Motoren in der Bauform IM B5 können auch in den Einbaulagen IM V1 und IM V3 eingesetzt werden; die Motoren in der Bauform IM B14 können auch in den Einbaulagen IM V18 und IM V19 eingesetzt werden.

In diesen Fällen ist auf dem Leistungsschild des Motors die Bauform IM B5 oder IM B 14 angegeben.

Bei Bauformen mit vertikaler Lage des Motors und nach unten gerichteter Welle wird die Ausführung mit Schutzdach empfohlen (bei Bremsmotoren stets vorzusehen). Diese Option muß zum Bestellzeitpunkt angegeben werden, da sie in der Grundausführung nicht berücksichtigt ist.

(F07)

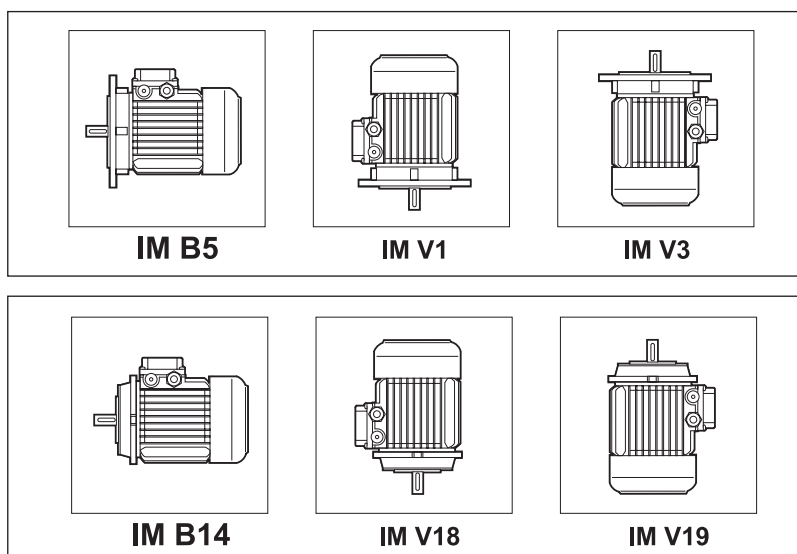

Für $BX \geq 200$ und $BX \geq 200K$ Motoren müssen die VM-Optionen ausgewählt werden, wenn sie vertikal montiert werden sollen.

Wenn der Motor mit DE nach unten montiert wird, wird die Auswahl der RC-Option empfohlen. Dies muss schon bei Bestellung angegeben werden, da sie in der Standardmotorversion nicht vorhanden ist.

Die Motoren mit Flansch können mit reduzierten Wellen und Flanschmaßen geliefert werden in der nachstehenden Tabelle - Ausführung **B5R**, **B14R**. Die Nutzung des Motors in Kombination mit einem Getriebe muss in Übereinstimmung mit der max. installierbaren Leistung des jeweiligen Getriebes erfolgen, siehe dazu Kapitel "Anbaumöglichkeiten". Im Fall dass die Kombination nicht zusammen passt, nehmen Sie bitte Kontakt mit dem Technischen Service von Bonfiglioli auf.

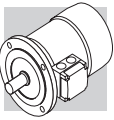

(F08)

	BN/BE 71	BX/BE/BN 80	BX/BE/BN 90	BX/BE/BN 100	BX/BE/BN 112	BX/BE/BN 132
	DxE - Ø					
B5R ⁽¹⁾	11x23 - 140	14x30 - 160	19x40 - 200	24x50 - 200	24x50 - 200	28x60 - 250
B14R ⁽²⁾	11x23 - 90	14x30 - 105	19x40 - 120	24x50 - 140	—	—

- (1) Flansch mit Durchgangslöchern
 (2) Flansch mit Gewindebohrungen

M6.2 Schutzart

IP..

In der nachstehenden Tabelle werden die jeweils zur Verfügung stehenden Schutzarten zusammengefasst.

Unabhängig von der spezifischen Schutzart müssen die im Freien installierten Motoren vor direkter Sonneneinstrahlung geschützt werden. Im Fall einer senkrechten Montage mit Wellenende nach unten, sollte darüber hinaus das Schutzdach bestellt werden, das vor dem Eindringen von Wasser und festen Fremdkörpern schützt (Option **RC**).

(F09)			IP 54	IP 55	IP 56
	BXN- BX-BE-BN	MXN-MX-ME-M	⊘	standard	 auf Anfrage
	BXN-BX-BE-BN/ FD*-FA	MXN-MX-ME-M/ FD-FA	standard	 auf Anfrage	⊘
	BX ≥ 200_FD BX ≥ 200K_FD		⊘	standard	⊘
	BX ≥ 280K_FD		⊘	standard	 auf Anfrage

(*) BX ≤ 180_FD



IP			5			5		
0		Nicht geschützt	0		Nicht geschützt			
1	 Ø 50 mm	Geschützt gegen feste Fremdkörper mit $\text{Ø} \geq 50 \text{ mm}$	1	 15°	Geschützt gegen senkrecht einfallendes Tropfwasser			
2	 Ø 12 mm	Geschützt gegen feste Fremdkörper mit $\text{Ø} \geq 12.5 \text{ mm}$	2	 15°	Geschützt gegen senkrecht einfallendes Tropfwasser bei Neigung bis 15°			
3	 Ø 2,5 mm	Geschützt gegen feste Fremdkörper mit $\text{Ø} \geq 2.5 \text{ mm}$	3	 60°	Regenwassergeschützt			
4	 Ø 1 mm	Geschützt gegen feste Fremdkörper mit $\text{Ø} \geq 1.0 \text{ mm}$	4	 60°	Spritzwassergeschützt			
5	 60°	Staubgeschützt	5	 60°	Wasserstrahigeschützt			
6	 60°	Kein Staubeintritt	6	 60°	Gegen starke Wasserstrahlen geschützt			
			7	 0,15 m 1 m	Kurzzeitig wasserdicht			
			8	 0,15 m 1 m	Nachhaltig wasserdicht			

M6.3 Kühlung

Die Motoren werden mittels Eigenbelüftung gekühlt (IC 411 gemäss CEI EN 60034-6) und sind mit einem Radiallüfterrad aus Kunststoff ausgestattet, welches in beiden Drehrichtungen wirksam ist. Bei der Installation muß sichergestellt werden, dass die Lüfterradabdeckung soweit vom nächsten Bauteil entfernt ist, daß der Lufteintritt nicht behindert wird und dass der Motor und (falls vorhanden) die Bremse problemlos gewartet werden können. Die Motoren können auf Anfrage mit einem unabhängig gespeisten Fremdlüfter geliefert werden (Option **U1**). Diese Ausführung sollte eingesetzt werden, falls der Motor über einen Frequenzumrichter bei kleinen Drehzahlen oder bei hoher Schaltfrequenz betrieben wird.

M6.4 Drehrichtung

Der Betrieb in beiden Drehrichtungen ist möglich. Schließt man die Klemmen U1, V1, W1 an die Phasen L1, L2, L3 an, dreht sich der Motor, mit Sicht auf die Motorwelle, im Uhrzeigersinn. Eine Drehung im Gegenuhrzeigersinn erhält man, indem man zwei Phasen tauscht.

M6.5 Geräuschpegel

Der Geräuschpegel wurde entsprechend der in der Norm ISO 1680 angegebenen Methode gemessen und liegt innerhalb der zulässigen Grenzwerte der Norm CEI EN 60034-9.

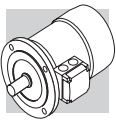



M6.6 Auswuchtung und Schwingstärke

Die Motoren werden dynamisch mit einer halben Passfeder ausgewuchtet und entsprechen dem Schwingstärkegrad A der Norm CEI EN 60034-14.

M6.7 Motorklemmkasten

Das Klemmenbrett älterer Motoren (BN/M - BE/ME - BX/MX) verfügt über 6 Stifte für den Ösenanschluss, während EVOX BXN- und MXN-Motoren standardmäßig immer 9 Stifte haben. Wenn bei einem älteren Motor die UL-Option aktiv ist, verfügt das Klemmenbrett über eine Ausführung mit 9 Stiften (für US-Spannung „Dual Voltage“). Im Klemmkasten ist ein Erdungsanschluss für den Anschluss des Schutzleiters vorgesehen. Die Abmessungen der Anschlüsse werden in der nachstehenden Tabelle angegeben. Für Informationen über die Bremsversorgung verweisen wir an dieser Stelle auf den Par. M9 (Bremsstyp FD), M10 (Bremsstyp FA). Bei den Bremsmotoren befindet sich der Gleichrichter mit den erforderlichen Anschlussklemmen für die Stromversorgung der Bremse innerhalb des Klemmkastens. Die elektrischen Anschlüsse müssen entsprechend den Schaltplänen, die sich im Inneren der Klemmkästen befinden, vorgenommen werden oder anhand der Angaben in den Betriebsanleitungen.



(F10)

		Klemmen	Gewinde
BXN 63 ... BXN 90	MXN05 ... MXN25	9	M4
BX 80, BX 90 BE 63 ... BE 90 BN 56 ... BN 90	MX2, MX3 ME05 ... ME3 M05 ... M2	6	M4
BX 100 ... BX 132 BE 100 ... BE 132 BN 100 ... BN 160MR	MX3, MX4 ME3, ME4 M3 ... M4	6	M5
BX 160 - BE 160 ... BE 180M BN 160M ... BN 180M	ME5 MX5 - M5	6	M6
BX 180 - BE 180L BN 180L ... BN 200L	—	6	M8
BX 200 ... BX 250 BX 200K ... BX 250K	—	6	M10
BX 280 ... BX 355 BX 280K ... BX 355K	—	6	M12
BX 80 ... BX 132 BE 71 ... BE 132 BN 63 ... BN 160MR	MX2 ... MX4 ME2 ... ME4 M05 ... M4	9	M4
BX 160 ... BX 180 BE 160 ... BE 180 BN 160M ... BN 200L	MX5 ME5 M5	9	M6

M6.8 Kabeleingang

Unter Berücksichtigung der Norm EN 50262 verfügen die Kabeleingänge in die Klemmkästen über metrische Gewinde, deren Maße, der nachstehenden Tabelle entnommen werden können.

(F11)

		Entrees de câbles et dimensions		maximal zulässiger Kabeldurchmesser [mm]
BXN 63	MXN 05	2 x M20 x 1.5	1+1 Bohrung pro Seite	13
		2 x M16 x 1.5		11
BXN 71 ... BXN 90	MXN 10 ... MXN 25	2 x M25 x 1.5	1 Bohrung pro Seite	17
		2 x M16 x 1.5		11
BN 63 - BE 63	M05 - ME05	2 x M20 x 1.5	1 Bohrung pro Seite	13
BN71 ... BN90, BE71 ... BE90, BX80 ... BX90	M1 - M2, ME1 - ME2, MX2	2 x M25 x 1.5		17
BN100 - BN112, BE100 - BE112, BX100 - BX112	MX3, MX4 - ME3 M3	2 x M32 x 1.5	2 Bohrungen pro Seite	21
		2 x M25 x 1.5		17
BN132 ... BN160MR, BE132, BX132	M4, ME4, MX4	4 x M32 x 1.5	Orientierbar 4 x 90°	21
BN160M ... BN200L, BE160 - BE180, BX160 - BX180	M5, ME5, MX5	2 x M40 x 1.5		28
BX 200 ... BX 355 BX 200K ... BX 355K	—	2 x M63 x 1.5	Orientierbar 4 x 90°	45



M6.9 Lager

Bei den Lagern handelt es sich um Radialkugellager mit Dauerschmierung. Die verwendeten Typen sind in der nachfolgenden Tabelle angegeben. Die Lebensdauer L10h der Lager, ohne Einfluss externer Kräfte, beträgt mehr als 40.000 Stunden (Berechnung gemäß ISO 281).

DE = Wellenseite

NDE = Lüfterseite

(F12)

	DE	NDE	
		Sans frein	Avec frein
MXN 05 - ME05 - M05	6004 2Z C3	6201 2Z C3	6201 2RS C3
MXN 10 - ME1 - M1	6004 2Z C3	6202 2Z C3	6202 2RS C3
MXN 20 - MX2 - ME2 - M2	6007 2Z C3	6204 2Z C3	6204 2RS C3
MXN 25 - MX3 - ME3 - M3	6207 2Z C3	6206 2Z C3	6206 2RS C3
MX4 - ME4 - M4	6309 2Z C3	6308 2Z C3	6308 2RS C3
MX5 - ME5 - M5	6309 2Z C3	6309 2Z C3	6309 2RS C3

	DE	NDE	
		Sans frein	Avec frein
BN 56	6201 2Z C3	6201 2Z C3	-
BXN 63 - BE 63 BN 63	6201 2Z C3	6201 2Z C3	6201 2RS C3
BXN 71 - BE 71 BN 71	6202 2Z C3	6202 2Z C3	6202 2RS C3
BXN 80 - BX 80 BE 80 - BN 80	6204 2Z C3	6204 2Z C3	6204 2RS C3
BXN 90 - BX 90 BE 90 - BN 90	6205 2Z C3	6205 2Z C3	6305 2RS C3
BX 100 - BE 100 - BN 100	6206 2Z C3	6206 2Z C3	6206 2RS C3
BX 112 - BE 112 - BN 112	6306 2Z C3	6306 2Z C3	6306 2RS C3
BX 132 - BE 132 - BN 132	6308 2Z C3	6308 2Z C3	6308 2RS C3
BN 160MR	6309 2Z C3	6308 2Z C3	6308 2RS C3
BX 160M/L - BE 160M/L - BN 160M/L	6309 2Z C3	6309 2Z C3	6309 2RS C3
BN 180M	6310 2Z C3	6309 2Z C3	6309 2RS C3
BX 180M/L - BE 180M/L - BN 180L	6310 2Z C3	6310 2Z C3	6310 2RS C3

	DE	NDE	
		Sans frein	Avec frein
BN 200L - BX 200 - BX 200K	6312 2Z C3 6312/C3	6310 2Z C3 6210/C3*	6310 2RS C3
BX 225 - BX 225K	6313/C3*	6212/C3*	-
BX 250 - BX 250K	6315/C3*	6213/C3*	-
BX 280 - BX 280K	6316/C3*	6316/C3*	-
BX 315 - BX 315K	6319/C3**	6316/C3**	-
BX 355 - BX 355K	6322/C3**	6316/C3**	-

*Hinweis: Schmierbare Lager mit M6x1-Schmiervorrichtung

**Hinweis: Schmierbare Lager mit M10x1-Schmiervorrichtung

Hinweis: BX- und BXN-Motoren sind mit Hochleistungslagern ausgestattet



M7 ELEKTRISCHE EIGENSCHAFTEN

M7.1 Spannung

Die einpoligen Motoren sind in der Standardausführung für eine Nennspannung von 230/400V Δ/Y oder 400/690V Δ/Y 50 Hz mit einer Spannungstoleranz $\pm 10\%$.

Hinweis: Die Nennspannung/ -frequenz des Motors hängt auch von der Auswahl von Optionen für Energieausweise für bestimmte Märkte ab. Die nachstehende Tabelle ist daher nur als Richtlinie gedacht. Weitere Informationen zu den verfügbaren Spannungen/ Frequenzen in Abhängigkeit von der ausgewählten Zertifizierung finden Sie in den Abschnitten M7.5 - M7.10.

Für alle Motoren, deren Spannungs-/Frequenzkonfiguration nicht wie oben angegeben ist, gelten reduzierte Spannungstoleranzen von $\pm 5\%$.

Bei einem Betrieb an den Toleranzgrenzen kann die Temperatur die vorgesehene Isolationsklasse um 10 K überschreiten. Diese Motoren eignen sich für einen

Betrieb im Europäischen Versorgungsnetz mit einer Spannung, die den in der Veröffentlichung IEC 60038 angegebenen Werten entspricht.

(F13)

Versorgungsspannungen BN-Motoren (IE1)				
50-Hz-Motoren mit einer Polarität				
Spannung der Motorversorgung	— (CE)		CCC	CUS
	STD	FD / FA		
220/380 - 50	X	✓	X	✓
230/400 - 50	✓	✓	✓	✓
240/415 - 50	X	✓	X	✓
290/500 - 50	✓	✓	X	✓
380/660 - 50	X	✓	X	✓
400/690 - 50	✓	✓	X	✓
415/720 - 50	X	✓	X	✓
500/865 - 50	✓	✓	X	✓
Motoren mit doppelter Polarität bei 50 Hz				
Spannung der Motorversorgung	— (CE)		CCC	CUS
	STD	FD / FA		
380 - 50	✓		X	✓
400 - 50	✓		✓	✓
415 - 50	✓		X	✓
500 - 50	✓		X	✓
60-Hz-Motoren mit einer Polarität				
Spannung der Motorversorgung	— (CE)		CCC	CUS
	STD	FD / FA		
208/360 - 60	✓	✓	X	✓
220/380 - 60	✓	✓	X	✓
230/400 - 60	✓	✓	X	✓
255/440 - 60	X	✓	X	✓
265/460 - 60	X	✓	✓	✓
280/480 - 60	X	✓	X	✓
330/575 - 60	✓	✓	X	✓
380/660 - 60	✓	✓	X	✓
400/690 - 60	✓	✓	X	✓
440/760 - 60	X	✓	X	✓
460/800 - 60	X	✓	X	✓
480/830 - 60	X	✓	X	✓
575/995 - 60	✓	✓	X	✓
220/440 - 60	✓	✓	X	✓
230/460 - 60	✓	✓	X	✓
240/480 - 60	✓	✓	X	✓
Motoren mit doppelter Polarität bei 60 Hz				
Spannung der Motorversorgung	— (CE)		CCC	CUS
	STD	FD / FA		
208 - 60	✓		X	✓
220 - 60	✓		X	✓
230 - 60	✓		X	✓
240 - 60	✓		X	✓
380 - 60	✓		X	✓
400 - 60	✓		X	✓
440 - 60	✓		X	✓
460 - 60	✓		X	✓
480 - 60	✓		X	✓
575 - 60	✓		X	✓



(F14)

Versorgungsspannungen BE-Motoren (IE2)						
50-Hz-Motoren mit einer Polarität						
Spannung der Motorversorgung	— (CE)	CCC	BIS	CUS		
220/380 - 50	✓	✗	✓	✓		
230/400 - 50	✓	✓	✓	✓		
240/415 - 50	✓	✗	✓	✓		
290/500 - 50	✓	✗	✓	✓		
380/660 - 50	✓	✗	✓	✓		
400/690 - 50	✓	✗	✓	✓		
415/720 - 50	✓	✗	✓	✓		
500/865 - 50	✓	✗	✓	✓		

60-Hz-Motoren mit einer Polarität						
Spannung der Motorversorgung	— (CE)		CCC	BIS	CUS	
	STD	FD / FA				
208/360 - 60	✓	✓	✗	✗	✓	
220/380 - 60	✓	✓	✗	✗	✓	
230/400 - 60	✓	✓	✗	✗	✓	
255/440 - 60	✓	✓	✗	✗	✓	
265/460 - 60	✗	✓	✗	✗	✓	
280/480 - 60	✓	✓	✗	✗	✓	
330/575 - 60	✗	✓	✗	✗	✓	
380/660 - 60	✓	✓	✗	✗	✓	
400/690 - 60	✓	✓	✗	✗	✓	
440/760 - 60	✓	✓	✗	✗	✓	
460/800 - 60	✗	✓	✗	✗	✓	
480/830 - 60	✓	✓	✗	✗	✓	
575/995 - 60	✓	✓	✗	✗	✓	
220/440 - 60	✓	✓	✗	✗	✓	
230/460 - 60	✓	✓	✗	✗	✓	
240/480 - 60	✓	✓	✗	✗	✓	

Versorgungsspannungen BX-Motoren (IE3)						
50-Hz-Motoren mit einer Polarität						
Spannung der Motorversorgung	— (CE)	CCC	CEL	NBR	BIS	CUS
230/400-50	✓ ⁽¹⁾	✗	✓ ⁽⁶⁾	✗	✗	✗
290/500-50	✓	✗	✗	✗	✗	✗
380/660-50	✗	✗	✓ ⁽⁴⁾	✗	✗	✗
400/690-50	✓ ⁽²⁾	✗	✓ ^{(2) (3)}	✗	✗	✗



60-Hz-Motoren mit einer Polarität							
Spannung der Motorversorgung	— (CE)		CCC	CEL	NBR ^(*)	BIS	CUS
	STD	FD / FA					
220/380-60	✗	✗	✗	✗	✓ ⁽³⁾	✗	✓
265/460-60	✗	✓ ⁽¹⁾	✗	✗	✗	✗	✓
330/575-60	✗	✓ ⁽³⁾	✗	✗	✗	✗	✓
380/660-60	✗	✗	✗	✗	✓ ⁽⁵⁾	✗	✓
440/760-60	✗	✗	✗	✗	✓ ⁽⁴⁾	✗	✓
460/800-60	✗	✓ ^{(2) (3)}	✗	✗	✗	✗	✓
220/440-60	✗	✗	✗	✗	✓ ⁽³⁾	✗	✓
230/460-60	✗	✗	✗	✗	✗	✗	✓

(1) nur für Motorbaugröße ≤132 (3) nur für Motorbaugröße ≤180 (5) nur für Motorbaugröße 180
(2) nur für Motorbaugröße ≥160 (4) nur für Motorbaugröße ≥200 (6) nur für Motorbaugröße ≥100



In der nachfolgenden Tabelle werden die verschiedenen Wicklungsanschlüsse in Abhängigkeit von den jeweiligen Polzahlen angegeben.

(F15)

Polzahl			Wicklungsanschluß
2	BE 80 ... BE 160, BN 63 ... BN 200	ME2 ... ME5, M05 ... M5	Δ / Y ⁽²⁾
4	BXN 63 ... BXN 90, BX 80 ... BX 355 BX 200LAK ... BX 355MCK BE 63 ... BE 180, BN 56 ... BN 200	MXN05 ... MXN25, MX2 ... MX5 — ME05 ... ME5, M05 ... M5	
6	BE 90 ... BE 160, BN 63 ... BN 200	ME3 ... ME5, M05 ... M5	
8	BN 71 ... BN 132	M1 ... M4	
2/4	BN 63 ... BN 132	M05 ... M4	Δ / YY (Dahlander)
2/6	BN 71 ... BN 132	M1 ... M4	Y / Y (Zwei wicklungen)
2/8	BN 71 ... BN 132	M1 ... M4	
2/12	BN 80 ... BN 132	M2 ... M4	
4/6	BN 71 ... BN 132	M1 ... M4	
4/8	BN 80 ... BN 132	M2 ... M4	Δ / YY (Dahlander)





⁽²⁾ Motoren mit dem Spannungsverhältnis 2 (z. B. 230/460V - 60Hz) werden mit einem 9-poligen Klemmbrett in ΔΔ/Δ oder YY/Y - Schaltung gefertigt (Ausnahme 6-polig BN 63 Δ/Y)

HINWEIS: Informationen zu BXN- und MXN-Motoren finden Sie im EVOX-Katalog

M7.2 Frequenz

Die Leistungsangabe auf dem Typenschild BN / M von 60 Hz Motoren entspricht den Daten aus der folgenden Tabelle:

(F16)

		P _n [kW]						P _n [kW]			
		2P	4P	6P	8P (*)			2P	4P	6P	8P (*)
BN 56A	—	—	0.07	—	—	BN 100L	M3LA	3.5	—	—	—
BN 56B	M0B	—	0.1	—	—	BN 100LA	M3LA	—	2.5	1.8	0.9
BN 63A	M05A	0.21	0.14	0.1	—	BN 100LB	M3LB	4.7	3.5	2.2	1.3
BN 63B	M05B	0.3	0.21	0.14	—	BN 112M	—	4.7	4.7	2.5	1.8
BN 63C	M05C	0.45	0.3	—	—	—	M3LC	—	4.7	2.5	—
BN 71A	—	0.45	0.3	0.21	0.1	BN 132S	M4SA	—	6.5	3.5	2.5
—	M1SC	—	—	0.21	—	BN 132SA	M4SA	6.5	—	—	—
BN 71B	M05SD	0.65	0.45	0.3	0.14	BN 132SB	M4SB	8.7	—	—	—
BN 71C	M1LA	0.9	0.65	0.45	—	BN 132M	M4LA	11	—	—	3.5
BN 80A	—	0.9	0.65	0.45	0.21	BN 132MA	M4LA	—	8.7	4.7	—
BN 80B	M2SA	1.3	0.9	0.65	0.30	BN 132MB	M4LB	—	11	6.5	—
BN 80C	M2SB	1.8	1.3	0.9	—	BN 160MR	M4LC	12.5	12.5	—	—
BN 90S	—	—	1.3	0.9	0.45	BN 160M	M5SA	—	—	8.7	—
BN 90SA	—	1.8	—	—	—	BN 160MB	—	17.5	—	—	—
BN 90SB	—	2.2	—	—	—	—	M5SB	17.5	17.5	—	—
BN 90L	M3SA	2.5	—	1.3	0.65	BN 160L	—	21.5	17.5	12.5	—
BN 90LA		—	—	1.8	—	—	M5SC	21.5	—	—	—
BN 90LB	—	—	2.2	—	—	BN 180M	M5LA	24.5	21.5	—	—
						BN 180L	—	—	25.3	17.5	—
						BN 200L	—	—	34	—	—
						BN 200LA	—	34	—	22	—

(*) Ausgeschlossen M_ Motoren



BXN / BX / BE / MXN / MX / ME sind nur in der 4poligen Ausführung für 60 Hz verfügbar. Die Leistungsdaten entsprechen der 50 Hz Ausführung. Bei polumschaltbare BN / M Motoren, die bei 60 Hz betrieben werden, kommt es zur Erhöhung der Nennleistung in Bezug auf die 50 Hz Werte um ca. 15%. BXN / BX / BE / MXN / MX / ME Motoren sind nicht als polumschaltbare Varianten verfügbar. Wenn die Nenndaten für 60 Hz Betrieb, vergleichbar mit den Nenndaten bei 50 Hz, auf dem Motortypenschild aufgeführt werden sollen, dann kann die Option PN gewählt werden. Die Motoren sind normalerweise für den Betrieb bei 50 Hz ausgelegt, können aber auch unter Berücksichtigung der folgenden Tabelle bei 60 Hz betrieben werden. Die Motoren, die für 50 Hz Betriebe bestimmt sind, zeigen auf das Namensschild auch die Werte für 60 Hz Betriebe (außer Motoren mit CUS Ausführung und Bremsmotoren). Siehe nachfolgende Tabelle.

(F17)

	50 Hz	60 Hz			
	V - 50 Hz	V - 60 Hz	P _n - 60 Hz	M _n , M _a /M _n - 60 Hz	n [min ⁻¹] - 60 Hz
BXN / MXN BX / MX BE / ME	230/400 Δ/Y	265 - 460 Δ Y	1	0.83	1.2
	400/690 Δ/Y	460 Δ			
BN / M	230/400 Δ/Y	220 - 240 Δ			
		380 - 415 Y			
	400/690 Δ/Y	380 - 415 Δ			
BN / M	230/400 Δ/Y	265 - 280 Δ			
		440 - 480 Y			
	400/690 Δ/Y	440 - 480 Δ			

HINWEIS: Informationen zu BXN- und MXN-Motoren finden Sie im EVOX-Katalog

M7.3 Umgebungstemperatur

Die im Katalog enthaltenen Tabellen geben die technischen Daten bei einer Frequenz von 50 Hz und normalen Umgebungsbedingungen gemäß den Normen CEI EN 60034-1 an (Temperatur 40 °C und Höhe ≤ 1000 m ü. d. M.).

Die Motoren können bei höheren Temperaturen zwischen 40 °C und 60 °C betrieben werden, wenn man die in der nachfolgenden Tabelle angegebenen Reduktionsangaben berücksichtigt.

(F18)

Umgebungstemperatur (°C)	40°	45°	50°	55°	60°
Zulässige Leistung in % der Nennleistung	100%	95%	90%	85%	80%

Bei Reduktionsfaktoren höher als 15 %, bitten wir um Rücksprache.

M7.4 Auf 50 HZ genormte Leistung

PN

Diese Option ermöglicht es auf dem Typenschild des Motors den Wert der auf 50 Hz genormten Leistung angeben zu können, auch wenn eine Spannungsversorgung bei 60 Hz erfolgt. Die Option PN ist immer dabei mit 60 Hz und Spannungsversorgung 230/460V und 575V 60 Hz.

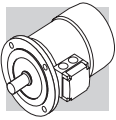

M7.5 Motoren für die USA und Kanada

CUS

Die Option CUS ist in der Ausführung Nema, Design C für BN, BE, M, ME Motoren und in der Ausführung Nema, Design B für BX Motoren erhältlich (hinsichtlich der elektrischen Eigenschaften). Die BXN- und MXN-Motoren sind standardmäßig CUS-zertifiziert. Die Motoren sind zertifiziert nach den Normen CSA (Canadian Standard) C22.2 Nr 100 und UL (Underwriters Laboratory) UL 1004-1, wie in der UL-Datei E308649 angegeben. Alle Leistungen BN-BE-M-ME und BXN-MXN mit Leistungen zwischen 0,12 und 0,55kW inklusive Motor-Typenschildern zeigen die folgenden Kennzeichen:



Die Typenschilder der Motoren BXN/MXN $\geq 0,75\text{kW}$ und BX/MX $\geq 0,75\text{kW}$ werden mit den nachstehend aufgeführten Symbolen gekennzeichnet und sind nach den in den USA und Kanada geltenden Energieeffizienzstandards zertifiziert, beziehungsweise geprüft durch DOE (10 CFR Part 431) und NRCan (Energy Efficiency Regulations) nach CSA C390 Standard.



Die Motoren BX 100, MX3LA und MX3LB sind nur für die USA und nicht für Kanada erhältlich und die Typenschilder werden mit den nachstehend aufgeführten Symbolen gekennzeichnet:



BX \geq 200K-Motoren zeigen auf dem Typenschild das unten angegebene Logo und entsprechen den Energieeffizienzvorschriften der USA und Kanadas, die von DOE (10 CFR Part 431) bzw. NRCan (Energy Efficiency Regulations) festgelegt und gemäß CSA C390 getestet wurden.



HINWEIS:

Ab dem **01.06.2016** können CUS Motoren deren Effizienzklasse unter IE3 (d.h. „Premium Efficiency“) liegt, nicht mehr in den USA und Kanada verkauft werden, außer die Motoren fallen unter eine oder mehrere der folgenden Ausnahmen:

- Polumschaltbare Motoren
- Motoren die nicht durchgehend betrieben werden (<80%)
- Motoren die nur über einen Frequenzumrichter betrieben werden und ordnungsgemäß mit einem „Inverter Duty Only“ Aufkleber oder ähnlichem ausgestattet sind

Die CUS Option kann nur für BX \geq 200K in Kombination mit U1 oder U2 ausgewählt werden. Die Spannungen der amerikanischen Verteilernetze und die entsprechenden Nennspannungen, die bei der Bestellung der Motore angegeben werden müssen, können der folgenden Tabelle entnommen werden:



(F19)

Frequenz	Netzspannung	V_{mot}
60 Hz	208 V	200 V
	240 V	230 V
	480 V	460 V
	600 V	575 V

BX-Motor mit CUS-Option sind mit folgenden Nennspannungs- / Frequenzkombinationen erhältlich:

(F20)

	V_{mot}
BX \leq 132	265/460 - 60 Hz
BX \leq 180	230/460 - 60 Hz 330/575 - 60 Hz
BX \geq 160 BX \geq 200K	460/800 - 60 Hz

CUS Option steht nur bei 50 HZ Betrieb zur Verfügung (Ausgeschlossen BX, MX Motoren).

M7.6 Zertifizierte Motoren für Indien

BIS

In Indien hergestellte oder importierte Niederspannungsmotoren $\geq 0,12$ kW müssen vom Bureau of Indian Standard zertifiziert sein und mit einem Zeichen versehen werden, das die Übereinstimmung des Motors mit dem Standard IS 12615 bestätigt.

BE/ME-Motoren mit einer Leistung bis 3,7 kW sind mit der oben genannten Zertifizierung erhältlich. Wenn die Option BIS ausgewählt wird, erhalten sie das Typenschild mit dem folgenden Logo:



M7.7 China Compulsory Certification

CCC

Die für den Vertrieb in der Volksrepublik China vorgesehenen Elektromotoren fallen unter den Geltungsbereich des Zertifizierungssystems CCC (China Compulsory Certification). Die Motoren der Serie BN/M und BE/ME mit Nenndrehmoment bis 7 Nm sind mit CCC-Zertifizierung und Sonder-typenschild mit der unten dargestellten Kennzeichnung erhältlich:



CCC Option ist nicht für IE3 Motoren verfügbar und wird ab Ende 2021 verfügbar sein.
CCC Option ist nicht für Motoren mit Fremdlüftung verfügbar.

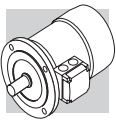

M7.8 Zertifizierte Motoren für China (China Energielabel)

CEL

In China hergestellte oder importierte Niederspannungsmotoren $\geq 0,75$ kW müssen vom Label Office zertifiziert und registriert und mit einem Energieetikett versehen werden, das bestätigt, dass sie die in GB18613-2012 definierten Energieeffizienzniveaus erfüllen.

BX-Motoren mit einer Leistung von 30 bis 355 kW sind mit der oben genannten Zertifizierung erhältlich. Wenn die Option CEL ausgewählt wird, wird der folgende Aufkleber mit dem Motor versehen:

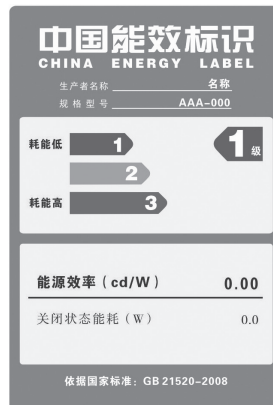

BX-Motoren mit CEL-Option sind mit folgenden Nennspannungs- / Frequenzkombinationen erhältlich:

(F21)		V_{mot}
	BX \geq 200	380/660 - 50 Hz

M7.9 Zertifizierte Motoren für Brasilien

NBR

Die brasilianischen Gesetze regeln die Herstellung und den Import von Elektromotoren im Land. Diese müssen von NBR durch eine Erklärung des Motorwirkungsgrades bei INMETRO genehmigt werden. NBR-konforme Motoren müssen den angegebenen Wirkungsgrad melden und mit einem spezifischen NBR-Typenschild und der in der folgenden Abbildung dargestellten Zusatzmarke versehen sein.



Die NBR-Option ist für Motoren verfügbar:

- BX mit Leistungen von 0.75 bis 22 kW enthalten
- BX... K mit Leistungen von 30 bis 355 kW inklusive



BX-Motoren mit NBR-Option sind mit folgenden Nennspannungs- / Frequenzkombinationen erhältlich:

(F22)

	V_{mot}
BX90SR ... BX160	220/380 - 60 Hz 220/440 - 60 Hz
BX 180	220/380 - 60 Hz 220/440 - 60 Hz 380/660 - 60 Hz
BX \geq 200K	440/760 - 60 HZ

M7.10 Zertifizierte Motoren für Australien

EECA

Der Elektromotor, der unter die australische/ neuseeländische Energieregulierung fällt, muss in der nationalen Datenbank Energyratig aufgeführt sein. Motoren mit EECA-Option sind in der zuvor genannten Datenbank registriert und können in Australien und Neuseeland verkauft werden. Die Option EECA ist für den BX ... K-Motor mit einer Leistung von 30 bis 355 kW erhältlich.

BX Motoren mit EECA Option sind mit folgenden Nennspannungs- / Frequenzkombinationen erhältlich:

(F23)

	V_{mot}
BX \geq 200K	400/690 - 50 Hz

M7.11 Isolationsklasse

CL F

Die Motoren von Bonfiglioli sind serienmäßig mit Isolierstoffen (Emaildraht, Isolierstoffen, Imprägnierharzen) der Klasse **F** ausgestattet. Allgemein bleiben die Motoren in der Standardausführung innerhalb des Grenzwertes von 80K, der einer Übertemperatur der Klasse B entspricht. Die sorgfältige Auswahl der Komponenten des Isoliersystem gestatten den Einsatz dieser Motoren auch unter tropischen Klimabedingungen und bei Vorliegen normaler Vibrationen. Für den Einsatz in in der Nähe aggressiv wirkender chemischer Substanzen oder bei hoher Luftfeuchtigkeit wird empfohlen, sich zur Wahl eines passendes Produktes mit unserem Technischen Kundendienst in Verbindung zu setzen.



CL H

Auf Anfrage können sie auch in der Klasse **H** geliefert werden.
 Diese Option kann für Motoren , die den CSA und UL Standards (CUS Option) entsprechen und nur für die Größen BX≥200 and BX≥200K ausgewählt werden.
 CLH kann bei BXN-Motoren nicht ausgewählt werden, da sie CUS-Standard sind. Wenden Sie sich bei Bedarf an das technische Büro.

(F25)

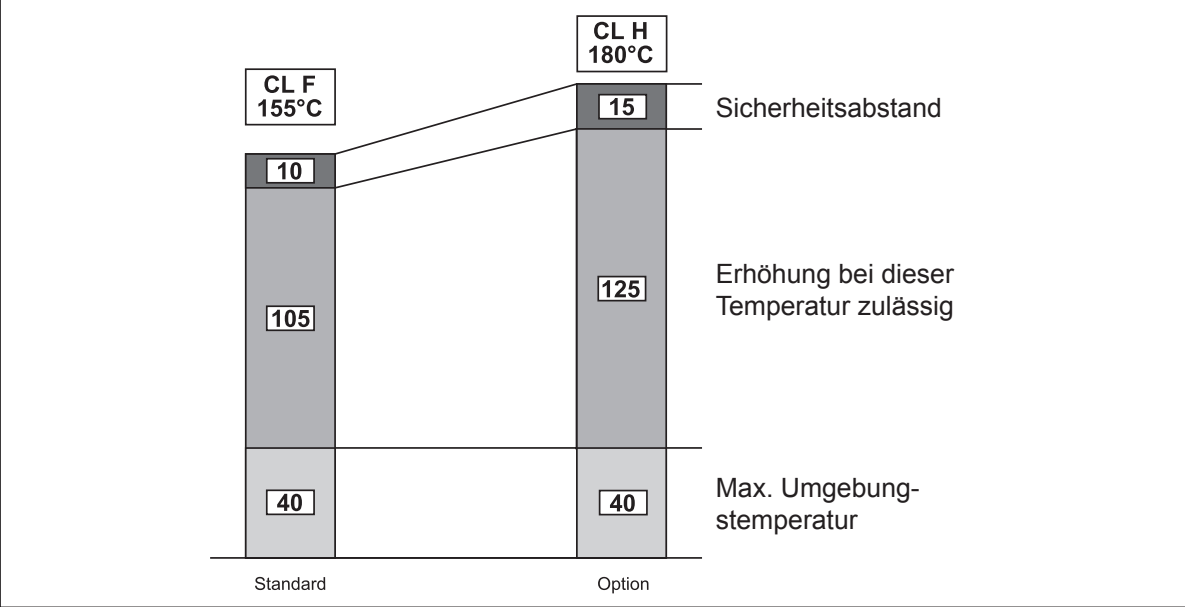

M7.12 Betriebsart

Sofern nicht anderweitig angegeben, beziehen sich die im Katalog angegebene Motorleistungen auf den Dauerbetrieb S1. Bei Motoren, die unter Bedingungen eingesetzt werden, die nicht mit S1 übereinstimmen, muss die entsprechende Betriebsart unter Bezugnahme auf die Normen CEI EN 60034-1 festgelegt werden. Insbesondere kann man, für die Betriebsarten S2 und S3, durch Anwendung der in der nachstehenden Tabelle angeführten Koeffizienten der für den Dauerbetrieb vorgesehenen Leistung gegenüber eine Leistungssteigerung erzielen. Diese Tabelle gilt für einpolige Motoren. Alternativ zum Dauerbetrieb S1 kann in der Konfigurationsphase des Produkts eine der folgenden Betriebsarten gewählt werden (nur für den einpoligen Motoren): S2, S3 oder S9. Auf dem Typenschild des Motors werden die erhöhte Leistung entsprechend der Betriebsart, die diesbezüglichen elektrischen Daten und als Betriebsart entweder S2-30min, S3-70% oder S9 angegeben. Für weitere Details bitte den technischen Kundendienst von Bonfiglioli kontaktieren. Für die polumschaltbaren Motoren sollte man sich im Hinblick auf den Leistungssteigerung, mit unserem Technischen Kundendienst in Verbindung setzen.

BN- und M-Motoren können standardmäßig für den Betrieb mit Einschaltdauer S2 (30 min) und S3 (70 %) konfiguriert werden. Andere Anforderungen, die in % oder min abweichen, gelten als Spezialität. BXN- und MXN-Motoren können standardmäßig auf S2=10min, S2=30min, S2=60min oder S3=25%, S3=40%, S3=70% konfiguriert werden.

(F24)

	Betriebsart						
	S2			S3 *			S4 - S9 Setzen Sie sich mit uns in Verbindung
	Dauer (min)			Schaltverhältnis (I)			
	10	30 (*)	60	25%	40%	70% (*)	
f _m	1.35	1.15	1.05	1.25	1.15	1.1	

* Die Zyklusdauer muß in jedem Fall kleiner oder gleich 10 Minuten sein. Wenn sie darüber liegt, bitte Rücksprache mit unserem Technischen Kundendienst.
 (*) Standardwert der Optionen (Tab. F05).



M7.12.1 Relative Einschaltdauer:

$$I = \frac{t_f}{t_f + t_r} \cdot 100 \quad (01)$$

t_f = Betriebszeit mit konstanter Last

t_r = Aussetzzeit

M7.12.2 Kurzzeitbetrieb S2

Betrieb mit konstanter Last für eine begrenzte Zeit, die unter der Zeit liegt, die zum Erreichen des thermischen Beharrungszustands benötigt wird, gefolgt von einer Pause, die so lang ist, dass der Motor nahezu wieder auf die Umgebungstemperatur abkühlen kann.

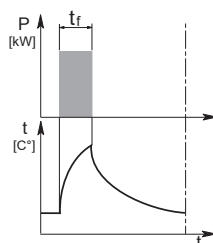

M7.12.3 Aussetzbetrieb S3:

Betrieb mit aufeinanderfolgenden, identischen Betriebszyklen, die alle einen Zeitraum mit konstanter Belastung und einer Pause beinhalten.

Bei dieser Betriebsart beeinflusst der Anlaufstrom die Übertemperatur nicht merklich.

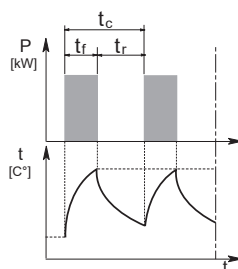

M7.13 Frequenzumrichterbetrieb

Die Elektromotoren Bonfiglioli können über PWM Frequenzumrichter bis 500 V Nennspannung am Umrichtereingang versorgt werden. Bei den Serienmotoren wird ein Phasenisolierungssystem mittels Wicklungstrenner, Emaildraht der Klasse 2 und Imprägnierharze der Klasse H eingesetzt (widerstandsfähig bei Spannungsimpulsen bis 1600 V Spitze-Spitze und Anstiegszeiten $t_s > 0.1 \mu s$ an den Motorklemmen). Die typischen Merkmale von Drehmoment/Geschwindigkeit im Betrieb S1 für Motoren mit einer Grundfrequenz $f_b = 50$ Hz werden in der nachstehenden Tabelle, verfügbar. Bei Betriebsfrequenzen unter ungefähr 30 Hz müssen die eigenbelüftenden Standardmotoren (IC411) aufgrund der in diesem Fall abnehmenden Kühlung entsprechend drehmomentreduziert oder, alternativ, fremdbelüftet betrieben werden. Bei über der Grundfrequenz liegenden Drehzahlen arbeitet der Motor nach Erreichen des max. Spannungswerts am Umrichterausgang in einem Feldschwächebereich mit konstanter Leistung mit einem reduziertem Drehmoment, welches ungefähr im Verhältnis (f/f_b) abnimmt. Da das Kippmoment des Motors ungefähr mit dem Faktor $(f/f_b)^2$ abnimmt, muss auch der zulässige Überlastungsgrenzwert entsprechend reduziert werden.

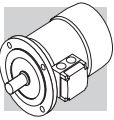

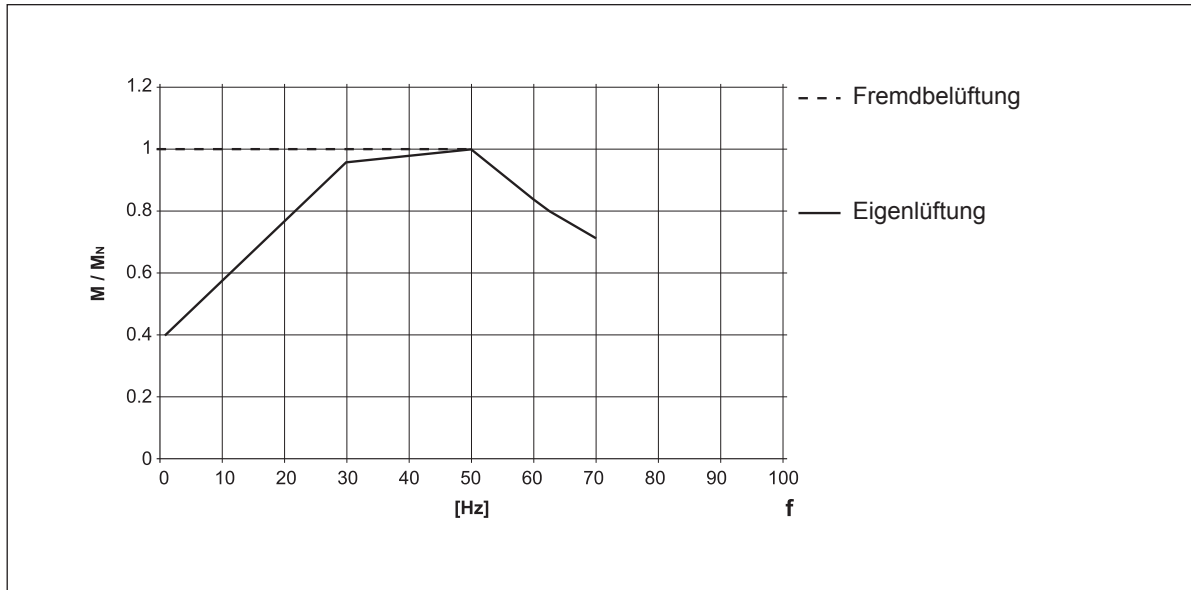

(F26)



Für Anwendungen, bei denen der Motor oberhalb der Eckfrequenz betrieben wird, finden sie die mechanische Drehzahlgrenzen in der folgenden Tabelle:

(F27)

			n [min ⁻¹]		
			2p	4p	6p
≤ BE 112 - BN 112		ME2, ME3 M05 ... M3	5200	4000	3000
≥ BE 132 - BN 132		ME4, ME5 M4, M5	4500	4000	3000
BXN 63 ... BXN 90		MXN 05 ... MXN 25		4000	
BX 80 ... BX 180		MX2 ... MX5		4000	

Bei Drehzahlen oberhalb der Nennwerte, treten stärkere mechanische Schwingungen und höhere Lüftergeräusche auf. Bei diesen Anwendungen wird ein Auswuchten des Rotors im Grad B und eventuell der Einsatz eines Fremdlüfters empfohlen. Der Fremdlüfter und, falls vorhanden, die elektromagnetische Bremse müssen immer direkt über das Netz gespeist werden.

M7.14 Maximale Schaltungshäufigkeit Z

In den Datentabellen der Motoren ist für den jeweiligen Bremsentyp die maximale Schaltungshäufigkeit im Leerlauf Z₀ bei relativer Einschaltdauer I = 50% angegeben. Dieser Wert definiert die maximale Anzahl von Anläufen im Leerlauf pro Stunde, ohne dass die maximal zulässige Wicklungstemperatur der Isolierstoffklasse F überschritten wird.

Wenn in der realen Anwendung beispielsweise ein Motor eine Last mit dem Massenträgheitsmoment J_c mit einem mittleren Anlauf-Lastmoment M_L antreibt und dabei die Leistung P_r benötigt, kann die max. zulässige Schalthäufigkeit mit folgender Formel überschlägig berechnet werden:

$$Z = \frac{Z_0 \cdot K_c \cdot K_d}{K_J} \quad (02)$$

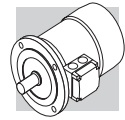

wo:

$$K_J = \frac{J_m + J_c}{J_m} \quad \text{Massenträgheitsfaktor}$$

$$K_c = \frac{M_a - M_L}{M_a} \quad \text{Drehmomentfaktor}$$

$$K_d = \quad \text{Lastfaktor, siehe folgende Tabelle}$$

(F28)

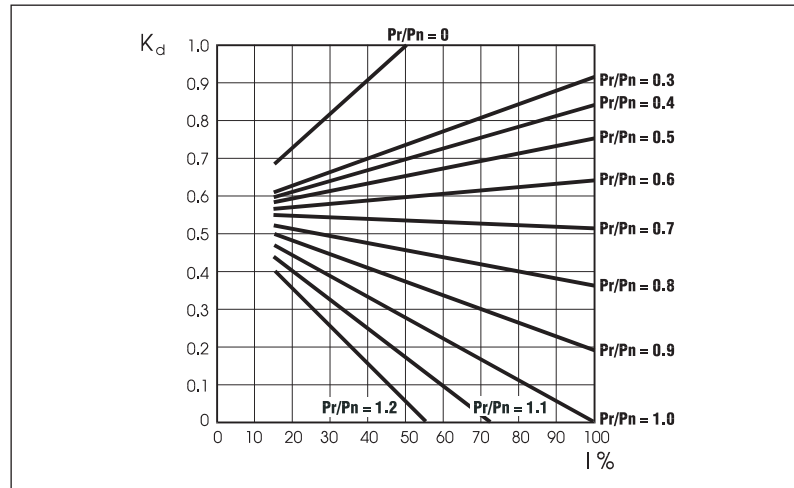

Auf Grundlage der berechneten Schaltspiele muss anschließend anhand der Tabellen (F38) und (F41) überprüft werden, ob die geforderte Bremsarbeit die Wärmegrenzleistung der Bremse W_{max} nicht überschreitet.

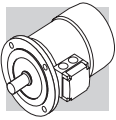

M8 DREHSTROMBREMSMOTOREN

M8.1 Betriebsweise

Die Bremsmotoren sind mit Federdruckbremsen ausgestattet, die mit Gleichstrom (Typ FD) oder mit Drehstrom (Typ FA) gespeist werden.

Alle Bremsen arbeiten gemäß dem sicheren Ruhestromprinzip, d.h. sie fallen bei Stromausfall über Federdruck ein.

(F29)

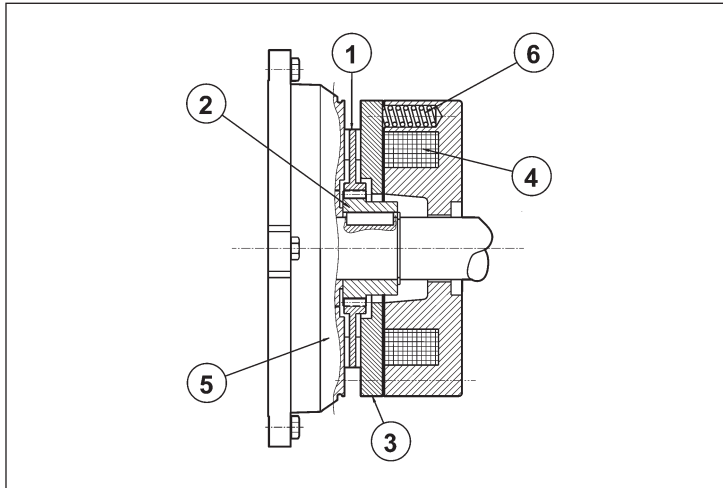

Zeichenerklärung:

- ① Bremsscheibe
- ② Nabe
- ③ Beweglicher Anker
- ④ Ringspule
- ⑤ Motorschild
- ⑥ Sprungfedern

Wenn die Spannungsversorgung unterbrochen wird, schieben Druckfedern den beweglichen Anker gegen die Bremsscheibe. Die Bremsscheibe wird zwischen der Ankerfläche und dem Motorschild gepresst und blockiert damit den Rotor. Wird die Spule erregt, wird der Anker durch das Magnetfeld gegen die Federkraft bewegt und die Bremsscheibe und damit auch der Rotor werden wieder frei gegeben.

M8.2 Allgemeine Eigenschaften

- Hohe und einstellbare Bremsmomente (allgemein $M_b \approx 2 M_n$).
- Bremsscheibe mit Stahlkern und doppeltem Bremsbelag (Material mit geringem Verschleiß, asbestfrei).
- Sechskant hinten an der Motorwelle, auf Lüfterradseite (N.D.E.), für eine manuelle.
- Drehung des Rotors mit einem Inbusschlüssel (nicht lieferbar, wenn die Optionen PS, RC, TC, U1, U2, EN1, EN2, EN3, EN4, EN5, EN6) bestellt werden.
- Manuell zu betätigende, mechanische Bremslüftvorrichtung (Optionen R und RM für FD; Optionen R für FA).
- Korrosionsschutzbehandlung an allen Flächen der Bremse.
- Isolierstoffklasse in Klasse F.

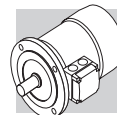

M9 DREHSTROMBREMSMOTOREN MIT GLEICHSTROMBREMSE: BXN-BX-BE-BN_FD und MXN-MX-ME-M_FD

Baugrößen: BXN 63 ... BXN 90, BX 80 ... BX 355M, BX200LAK ... BX 355MCK - BE 63 ... BE 180L - BN 63 ... BN 200L / MXN 05 ... MXN 25 - MX2SB ... MX5LA - ME05 ... ME5 - M05 ... M5

(F30)

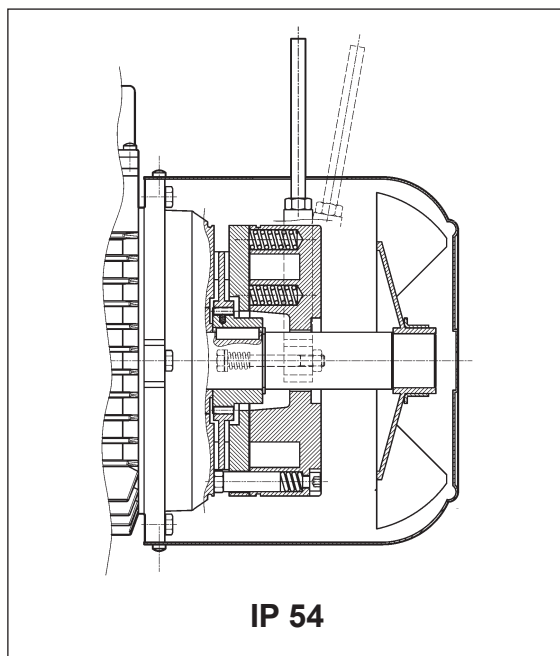

IP 54

(F31)

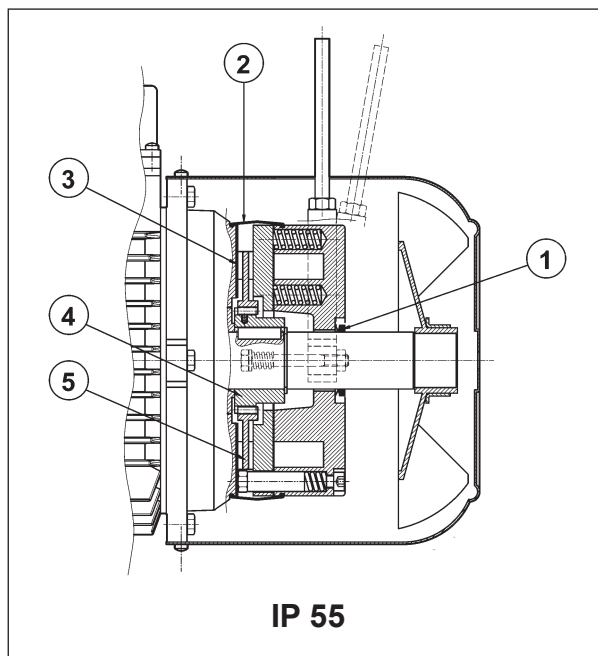

IP 55

Elektromagnetische Bremse mit Ringwicklungsspule für **Gleichstromspannung**, die mittels Schrauben am hinteren Motorschild befestigt ist. Die Federn sorgen für die axiale Ausrichtung des Magnetkörpers. Die Bremsscheibe gleitet auf der Mitnehmernabe aus Stahl; die Nabe ist an der Welle aufgezogen und mit Schwingungsdämpfung versehen. Die Motoren werden vom Hersteller auf das in der Tabelle der technischen Daten angegebenen Bremsmoment eingestellt. Das Bremsmoment kann durch das Ändern des Typs und/oder der Anzahl der Federn eingestellt werden. Auf Anfrage können die Motoren mit einem Bremslüfthebel für die manuelle Lüftung der Bremse mit selbsttätiger Rückstellung (**R**) ohne Arretierung oder mit arretierbarem Lüfthebel (**RM**) geliefert werden. Die Festlegung der möglichen Positionen des Bremslüfthebels in Abhängigkeit von der Klemmkastenlage erfolgt durch die Optionsbeschreibung im Abschnitt "BREMSLÜFTHEBEL".

Die Bremse vom Typ FD garantiert hohe dynamische Leistungen und niedrige Laufgeräusche. Die Ansprechigenschaften der Bremse unter Gleichstrom können je nach Bedarfsfall durch den Einsatz der verschiedenen verfügbaren Gleichrichter oder durch einen entsprechenden Bremsanschluss optimiert werden.

Für Anwendungen, bei denen Hubvorgänge und/oder hohe Werte stündlich anfallender Arbeit vorgesehen sind, bitte den technischen Kunden-/Vertriebsdienst kontaktieren.



M9.1 Schutzart

Der Standardschutzgrad für BN - M, BE - ME, BX \leq 180 - MX \leq 5 und BXN - MXN, während für BX \geq 200 und BX \geq 200K der Standardschutzgrad IP55 beträgt.

Der Bremsmotor BN - M, BE - ME, BX \leq 180 - MX \leq 5 und BXN - MXN mit der Standardschutzart IP54 kann mit der Schutzart IP55 angefordert werden. Bei Auswahl von **IP55** werden folgende Konstruktionsvarianten angewendet:

- ① V-Ring an der Motorwelle N.D.E.
- ② staub- und wasserdichte Gummischutz
- ③ Ring aus rostfreiem Stahl zwischen Motorschild und Brems Scheibe
- ④ Mitnehmernabe aus rostfreiem Stahl
- ⑤ Brems Scheibe aus rostfreiem Stahl

M9.2 Spannungsversorgung der Bremse FD

Die Versorgung der Gleichstrombremsspule erfolgt über einen Gleichrichter im Klemmkasten, der, falls nichts anderes angegeben ist, werkseitig mit der Bremspule verdrahtet ist.

Unabhängig von der Netzfrequenz erfolgt die Versorgung der Bremse V_B über die in der nachstehenden Tabelle angegebenen Spannungen:

(F32)

Versorgungsspannung der Bremsen V	Spannung Bremsstromversorgung FA		
	Stromversorgung vom Motor mit Gleichrichter	Bremse FD Separate Stromversorgung mit Gleichrichter	Spannungsversorgung ohne Gleichrichter
24	X	X	✓
100	X	X	✓
110	X	✓	X
115	X	✓	X
120	X	✓	X
127	X	✓	X
180	X	X	✓
208	✓	✓	X
220	✓	✓	X
230	✓	✓	✓
240	✓	✓	X
255	✓	X	X
265	✓	X	X
280	✓	X	X
290	✓	X	X
330	✓	X	X
380	✓	✓	X
400	✓	✓	X
415	✓	✓	X
440	✓	✓	X
460	✓	✓	X
480	✓	✓	X
500	✓	✓	X





HINWEIS: Informationen zu BXN- und MXN-Motoren finden Sie im EVOX-Katalog

Bei polumschaltbaren Motoren erfolgt die Bremsstromversorgung zwingend über eine separate Leitung:

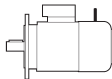

Bei dem Gleichrichter handelt es sich um einen Typ mit Einwegschialtung (VDC \approx 0,45 VAC). Er ist in den Versionen **NB**, **SB**, **NBR** und **SBR**, gemäß den Details in der nachstehenden Tabelle, verfügbar:

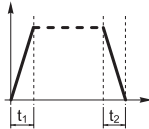
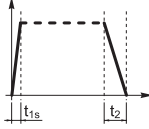
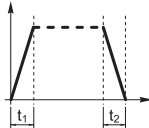
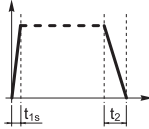
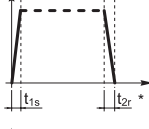
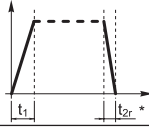
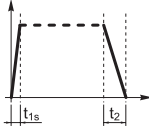
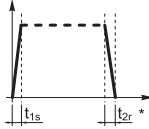
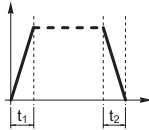
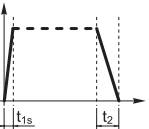
(F33)

			Bremsse			
				standard	auf Anfrage	
BXN 63		MXN05	FD 02	NB 	SB 	
BXN 71		MXN10	FD 53			
BXN 80		MXN20	FD 04			
BXN 90		—	FD 05			
BE 63 - BN 63		ME05 - M05	FD 02	NB 	SB 	
BE 71 - BN 71		ME1 - M1	FD 03 FD 53			
BX 80 - BE 80 - BN 80		MX2 - ME2 - M2	FD 04		SBR 	
BX 90S - BE 90S - BN 90S		—	FD 14			
BX 90L - BE 90L - BN 90L		—	FD 05			
BX 100 - BE 100 - BN 100		MX3 - ME3 - M3	FD 15		NBR 	
—			FD 55			
BX 112 - BE 112 - BN 112		—	FD 06S		SB 	SBR 
BX 132 - BE 132 - BN 132 - BN 160MR		MX4 - ME4 - M4	FD 56 FD 06 FD 07			
BX 160 - BE 160L - BN 160L - BN 180M		MX5 - ME5 - M5	FD 08			
BX 180 - BE 180L - BN 180L - BN 200M		—	FD 09			
BX 200LA		—	FD 20			
BX 225SA		—	FD 25	NB 	SB 	
BX 250M - BX 315SA		—	FD 30			
BX 315SB - BX 315SC		—	FD 160			
BX 315MA - BX 355MA		—	FD 250			
BX 355MB - BX 355MC		—	FD 400			
BX 200LAK		—	FD 8			
BX 225SAK - BX 225SBK		—	FD 9			
BX 250MAK		—	FD 10			
BX 280SAK - BX 315SAK		—	FD 1000			
BX 315SBK - BX 315SCK		—	FD 1600			
BX 355SAK - BX 355MCK		—	FD 2500			

(*) $t_{2c} < t_{2r} < t_2$

Informationen zu BXN-Motoren finden Sie im Abschnitt „Bremsen“ im EVOX-Katalog.

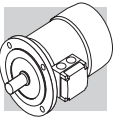

Der Gleichrichter **SB** mit elektronischer Kontrolle der Erregung reduziert die Bremslützeiten, indem er die Bremsspule im Einschaltmoment übermäßig stark erregt, um dann, nach erfolgtem Lüftvorgang, in die normale Gleichrichterschaltung umzuschalten.

Der Einsatz des Gleichrichtertyps **SB** wird bei folgenden Einsatzfällen empfohlen:

- hohe Schalthäufigkeit
- kurze Bremslützeiten
- starke thermische Beanspruchung der Bremse

Für die Anwendungen mit schnellen Bremsenreaktionszeiten (Öffnungszeit der Bremse) , können auf Anfrage die Gleichrichter **NBR** oder **SBR** geliefert werden.

Diese Gleichrichter erweitern die Funktion der Typen **NB** und **SB**, indem bei Spannungsunterbrechung ein elektronischer Schaltkreis einen Kontakt öffnet und dadurch die Magnetspule schnell entregt wird.

Diese Lösung ermöglicht eine Verkürzung der Bremsansprechzeiten ohne zusätzlichen Schaltungsaufwand.

Bestmögliche Performance wird bei den Gleichrichtern **NBR** und **SBR** mit einer separaten Versorgungsspannung erreicht.

Verfügbare Spannungen: 230VAC \pm 10%, 400VAC \pm 10%, 50/60 Hz (mit Gleichrichter); 100VDC \pm 10%, 180VDC \pm 10% (mit Option SD).



M9.3 Technische Daten - Bremsentyp FD

In der nachstehenden Tabelle werden die technischen Daten der Gleichstrombremsen vom Typ FD angegeben.

(F34)

Bremsen	Bremsmoment M_b [Nm]			Ansprechzeit		Bremsvorgang		W_{max} pro Bremsvorgang			W [MJ]	P [W]
	feder			t_1 [ms]	t_{1s} [ms]	t_2 [ms]	t_{2c} [ms]	[J]				
	6	4	2					10 s/h	100 s/h	1000 s/h		
FD02	–	3.5	1.75	30	15	80	9	4500	1400	180	15	17
FD03	5	3.5	1.75	50	20	100	12	7000	1900	230	25	24
FD53	7.5	5	2.5	60	30	100	12					
FD04	15	10	5	80	35	140	15	10000	3100	350	30	33
FD14												
FD05	40	26	13	130	65	170	20	18000	4500	500	50	45
FD15	40	26	13	130	65	170	20					
FD06S	60	40	20	–	80	220	25	20000	4800	550	70	55
FD56	–	75	37	–	90	250	20	29000	7400	800	80	65
FD06		100	50		100	250	20					
FD07	150	100	50	–	120	200	25	40000	9300	1000	130	65
FD08*	250	200	170	–	140	350	30	60000	14000	1500	230	100
FD09**	400	300	200	–	200	450	40	70000	15000	1700	230	120
FD20	260			100	170	340	–	80000	1700	1800	–	100
FD25	400			120	195	390	–	120000	19000	2000	–	110
FD30	1000			180	210	420	–	200000	28000	2900	–	200
FD160	1600			360	245	490	–	240000	36000	2600	–	336
FD250	2500			420	343	685	–	280000	47000	3700	–	400
FD400	4000			530	455	910	–	325000	51000	4500	–	420
FD8	400			176	78	236	–	65000	7000	650	–	85
FD9	600			324	138	176	–	120000	12000	1200	–	100
FD10	800			480	194	172	–	100000	16000	2000	–	150
FD1000	1000			252	–	375	–	220000	27000	2700	–	300
FD1600	1600			366	–	498	–	230000	35000	3500	–	340
FD2500	2500			660	–	880	–	590000	61000	6100	–	530

* erreichte Bremsmomentwerte, die durch den Einsatz von jeweils 9, 7, 6 Federn erreicht werden

** Werte, der durch den Einsatz von jeweils 12, 9, 6 Federn erreichten Bremsmomente

t_1 = Ansprechzeit der Bremse mit Einweggleichrichter
 t_{1s} = Ansprechzeit der Bremse mit elektronisch gesteuertem Gleichrichter
 t_2 = Bremsverzögerung mit Unterbrechung auf Wechselstromseite und Fremdversorgung
 t_{2c} = Bremsverzögerung mit Unterbrechung auf Wechselstrom- und Gleichstromseite – Die in der Tab. (F30) angegebenen Werte t_1 , t_{1s} , t_2 , t_{2c} beziehen sich auf eine Bremse mit eingestelltem max. Bremsmoment, mit mittlerem Luftspalt und bei Nennspannung
 W_{max} = max. Energie pro Bremsvorgang
W = Bremsenergie zwischen zwei Einstellungen des Luftspalts
 P_b = bei 20° C von der Bremse aufgenommene Leistung (50 Hz)
 M_b = statisches Bremsmoment ($\pm 15\%$)
s/h = Schaltspiele pro Stunde

Der Verschleiß der Reibdichtungen ist von den Betriebsbedingungen abhängig (Temperatur, Feuchtigkeit, Schlupfgeschwindigkeit, spezifischer Druck); die Verschleißangaben sind demnach als Richtwerte zu betrachten.

M9.4 Anschlüsse - Bremsentyp FD

Die einpoligen Motoren werden mit werkseitig an das Motorklemmbrett angeschlossenen Gleichrichtern geliefert. Bei den polumschaltbaren Motoren und bei Bremsen mit separater Versorgung werden die Gleichrichter kundenseitig mit einer auf dem Typenschild angegebenen Bremsenspannung VB angeschlossen. **Da es sich bei der Bremsspule um eine induktive Last handelt, müssen gemäß IEC 60947-4-1 für die Ansteuerung der Bremse und die Unterbrechung der Gleichstromseite Kontakte der Kategorie AC-3 verwendet werden.**



Tabelle (F35+F39) – Bremsspule mit Stromversorgung von Motorklemmen (DIR) und AC-Leitungsunterbrechung. Verzögerter und von den Zeitkonstanten des Motors abhängige Haltezeit t_2 . Vorzusehen, wenn möglichst ruckfreie Starts/Stopps gefordert sind.

Tabelle (F36+F40) – Bremsspule mit separater Stromversorgung (SA) und Unterbrechung der Wechselstromseite. Normale und vom Motor unabhängige Stoppszeiten. Es werden die in der Tabelle (F34) angegebenen Stoppszeiten t_2 realisiert.

Tabelle (F37+F41) – Bremsspule mit Stromversorgung von Motorklemmen (DIR) und AC/DC-Leitungsunterbrechung. Schneller Stopp mit den in der Tabelle (F34) angegebenen Ansprechzeiten t_{2c} .

Tabelle (F38+F42) – Bremsspule mit separater Stromversorgung (SA) und Unterbrechung der Gleich- und der Wechselstromseite.

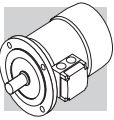
Reduzierte Stoppszeiten mit den in der Tabelle (F34) angegebenen Werten t_{2c} .

Die Bremsspannungsversorgung über die Motorspannung (tab. F35-F39 und tab. F37-F41) darf nur erfolgen wenn die Nennspannung der Bremse der geringeren Nennspannung des Motors entspricht.

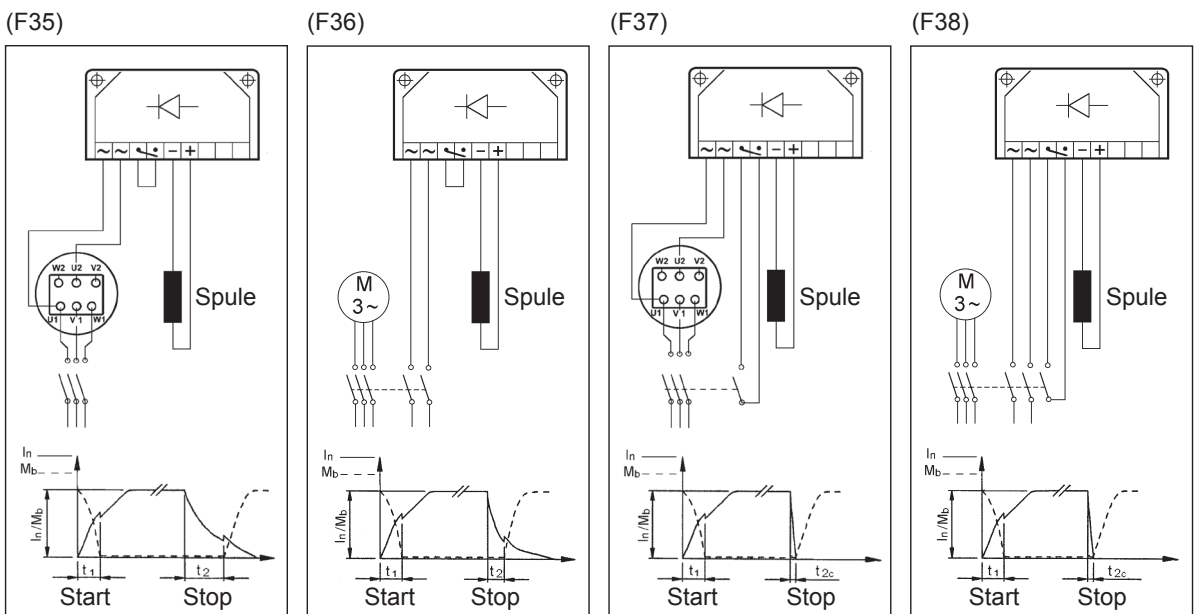

Für BXN- und MXN-Motoren ist das Anschlussschema der FD-Bremse wie folgt:

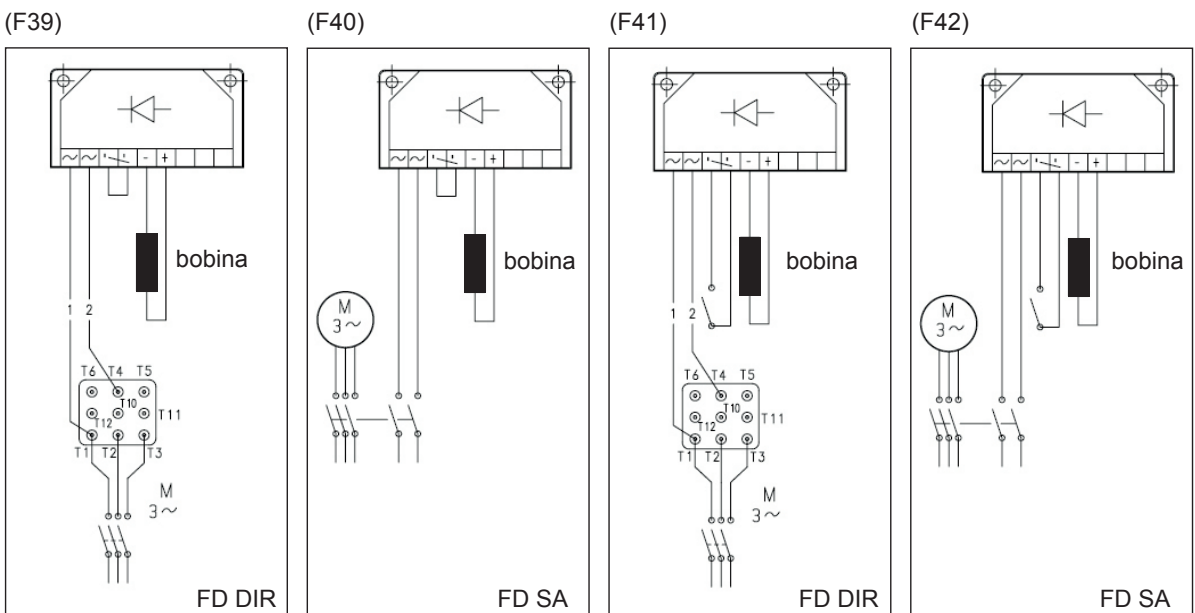

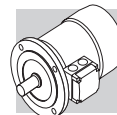

M10 DREHSTROMBREMSMOTOREN MIT DREHSTROMBREMSE: TYP BXN-BX-BE-BN_FA und MXN-MX-ME-M_FA

Baugrößen: BXN 63 ... BXN 90, BX 80 ... BX 160L - BE 63 ... BE 160L - BN 63 ... BN 180M / MXN 05 ... MXN 25 - MX2SB ... MX5LA - ME05 ... ME5 - M05 ... M5

(F43)

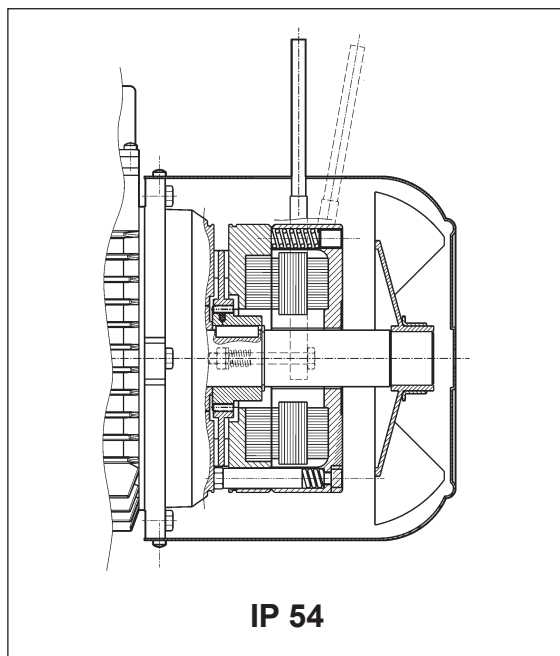

(F44)

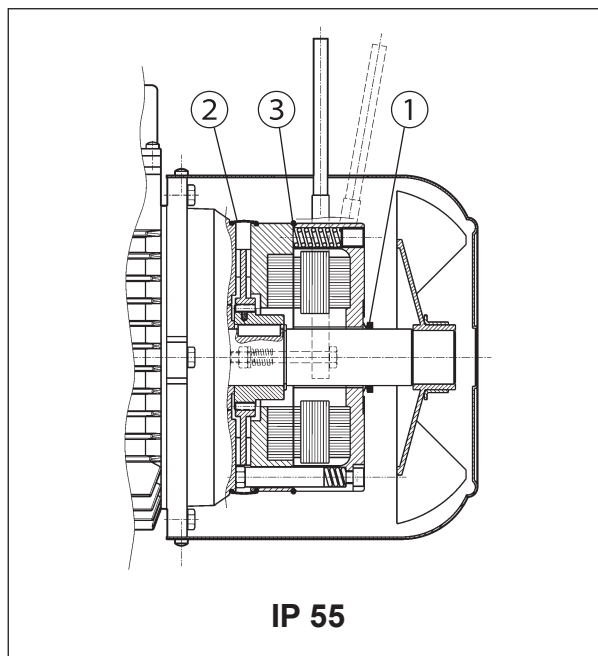

Elektromagnetische Bremse mit Drehstromversorgung, die mittels Schrauben am hinteren Motorschild befestigt ist. Die Federn sorgen dabei für die axiale Ausrichtung des Magnetkörpers. Die Bremsscheibe (Stahl) gleitet axial auf dem sich auf dem Rotor befindlichen Mitnehmer, der über eine Paßfeder mit Motorwelle verbunden und mit Schwingungsdämpfung ist als Bremsmoment wird auf das entsprechende Motormoment eingestellt (siehe Tabelle der technischen Daten der entsprechenden Motoren). Das Bremsmoment ist stufenlos über die Schrauben der Federvorspannung einstellbar. Der Einstellbereich beträgt $30\% M_{bMAX} < M_b < M_{bMAX}$ (M_{bMAX} steht für das in der Tab (F45) angegebene max. Bremsmoment).

Die Bremsen vom Typ FA zeichnen sich durch eine hohe Dynamik aus, weshalb sie für Anwendungen geeignet sind, in denen hohe Schaltfrequenzen und schnelle Ansprechzeiten gefordert werden. Auf Anfrage können die Motoren mit einem Lüfthebel für die manuelle Lüftung der Bremse mit automatischer Rückstellung (R) geliefert werden. Die Festlegung der möglichen Positionen des Bremslüfthebels in Abhängigkeit von der Klemmkastenlage erfolgt durch die Optionsbeschreibung im Abschnitt "BREMSLÜFTHEBEL".

Für Anwendungen, bei denen Hubvorgänge und/oder hohe Werte stündlich anfallender Arbeit vorgesehen sind, bitte den technischen Kunden-/Vertriebsdienst kontaktieren.

M10.1 Schutzart

Die Standardausführung hat Schutzart IP54 vor.

Optional kann der Bremsmotor FA auch in der Schutzart **IP55** geliefert werden, was durch die folgenden zusätzlichen Bauteile erreicht wird:

- ① V-Ring an der Motorwelle N.D.E.
- ② staub- und wasserdichte Gummischutz
- ③ O-ring

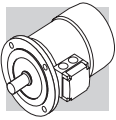

M10.2 Spannungsversorgung - Bremsentyp FA

Bei den einpoligen Motoren kann die Stromversorgung direkt vom Motorklemmenkasten zur Brems-
spule gebracht werden. Bei polumschaltbaren Motoren und bei separater Versorgungsspannung ist
ein Hilfsklemmbrett mit 6 Anschlüssen vorgesehen, die einen Anschluss der Bremse ermöglichen.
Auf alle Fälle muss die Bremsenspannung in der Bestellung angegeben werden.

In der nachstehenden Tabelle werden für die einpoligen und die polumschaltbaren Motoren die
Standardspannungen der Wechselstrombremsen angegeben.

(F45)

Versorgungsspannung der Bremsen V	Spannung Bremsstromversorgung FA	
	Bremsen FA	
	Motorstromversorgung bei 50Hz	Motorstromversorgung bei 60Hz
208	✗	✓
220	✗	✓
230	✓	✓
240	✗	✓
380	✓	✓
400	✓	✓
415	✓	✗
440	✗	✓
460	✗	✓
480	✗	✓
500	✓	✗
575	✗	✓

HINWEIS: Informationen zu BXN- und MXN-Motoren finden Sie im EVOX-Katalog

Auf Anfrage können Sonderspannungen geliefert werden.

M10.3 Technische Daten der Bremsen vom Typ FA

(F46)

Bremsen	Bremsmoment M_b [Nm]	Ansprechzeit t_1 [ms]	Bremsvorgang t_2 [ms]	W_{max} [J]			W [MJ]	P [VA]
				10 s/h	100 s/h	1000 s/h		
FA 02	3.5	4	20	4500	1400	180	15	60
FA 03	7.5	4	40	7000	1900	230	25	80
FA 04	15	6	60	10000	3100	350	30	110
FA 14								
FA 05	40	8	90	18000	4500	500	50	250
FA 15								
FA 06S	60	16	120	20000	4800	550	70	470
FA 06	75	16	140	29000	7400	800	80	550
FA 07	150	16	180	40000	9300	1000	130	600
FA 08	250	20	200	60000	14000	1500	230	1200

M_b = statisches max. Bremsmoment ($\pm 15\%$)

t_1 = Bremsenansprechzeit

t_2 = Bremsverzögerung

W_{max} = max. Energie pro Bremsvorgang (Wärmeleistung der
Bremse)

W = Bremsenergie zwischen zwei Einstellungen des Luftspalts

P_b = bei 20° von der Bremse aufgenommene Leistung (50 Hz)

s/h = Schaltspiele pro Stunde

HINWEIS:

Die in der Tabelle angegebenen Werte
 t_1 und t_2 beziehen sich auf eine Bremse
mit eingestelltem Nenndrehmoment,
einen mittleren Luftspalt und mit Stan-
dardspannung.



Der Verschleiß der Reibdichtungen ist von den Betriebsbedingungen abhängig (Temperatur, Feuchtigkeit, Schlupfgeschwindigkeit, spezifischer Druck); die Verschleißangaben sind demnach als Richtwerte zu betrachten.

M10.4 Anschlüsse - Bremsentyp FA

Bei den Motoren mit direkter Bremsenspannungsversorgung müssen die Anschlüsse im Klemmkasten entsprechend den Angaben im der folgenden Schema vorgenommen werden:

(F47)

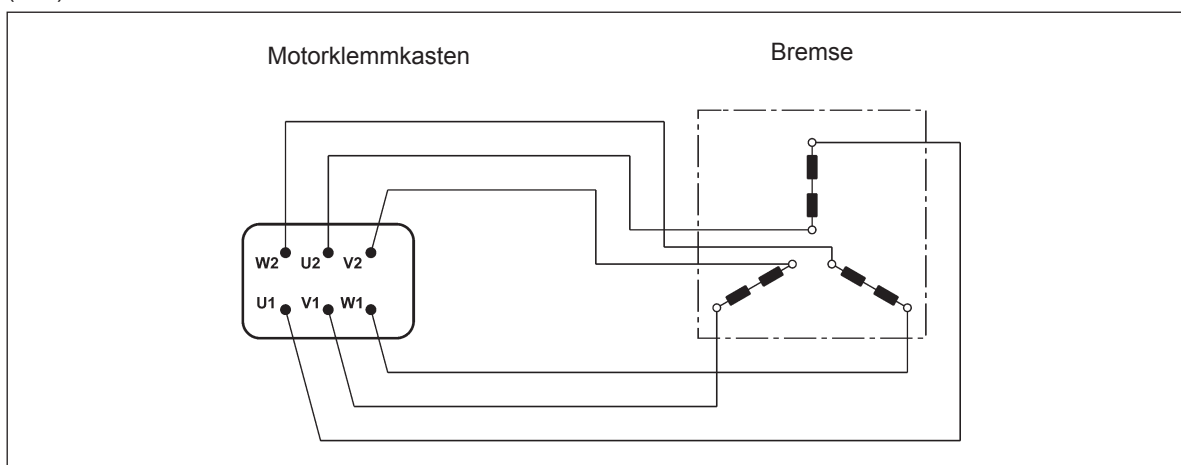

Für BXN- und MXN-Motoren ist das Anschlussschema der FA-Bremse wie folgt:

(F48)

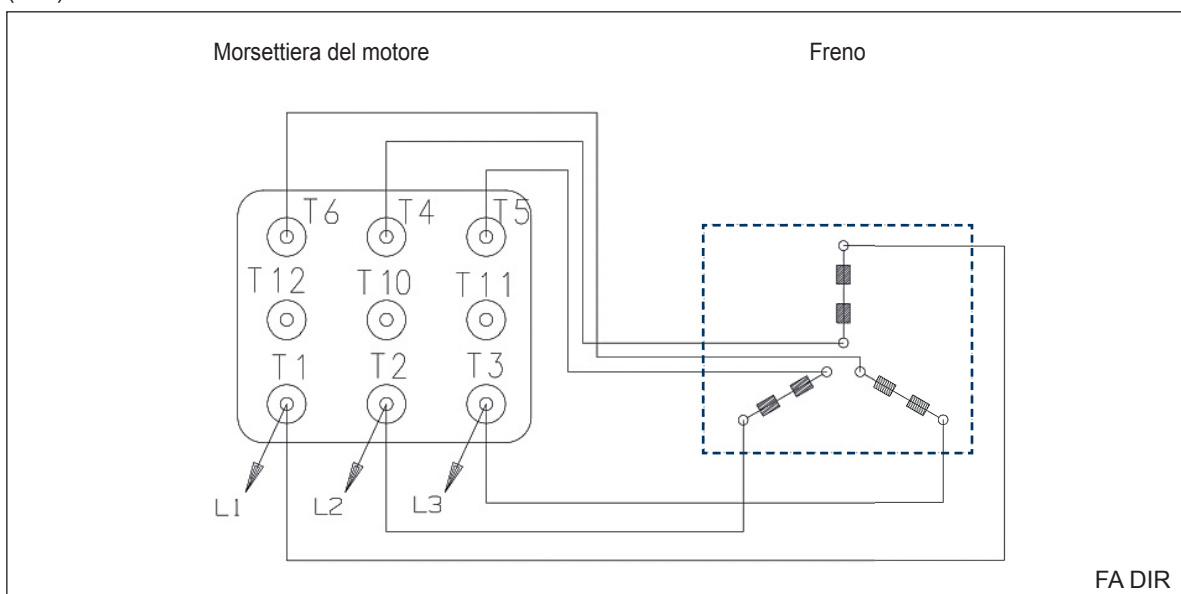

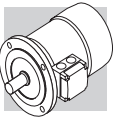

Bei den polumschaltbaren Motoren und, auf Anfrage, auch bei den einpoligen Motoren mit separater Versorgungsspannung ist für den Anschluss der Bremse ein Hilfsklemmbrett mit 6 Anschlüssen vorgesehen. Dann haben die Motoren einen größeren Klemmkasten. Siehe im der folgenden Schema:

(F49)

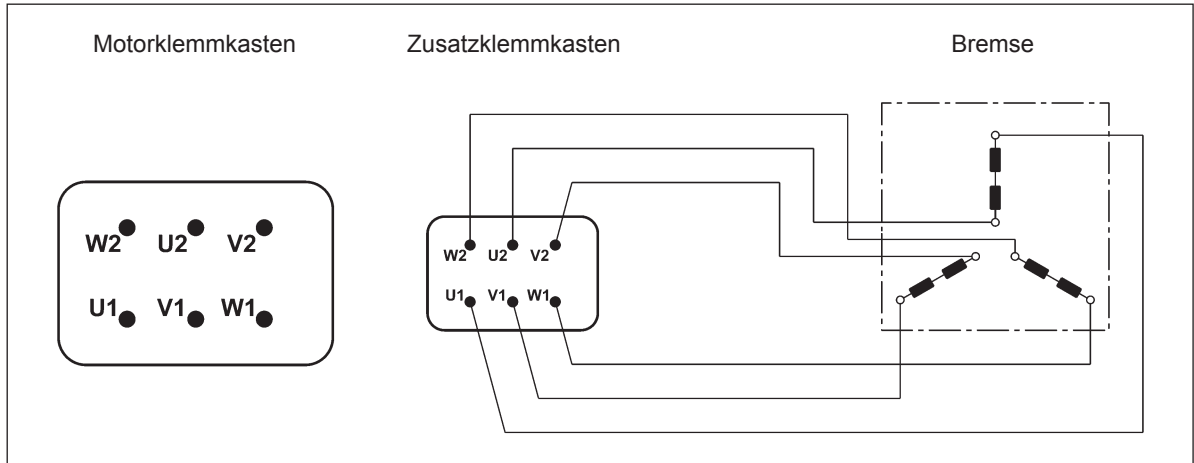

Für BXN- und MXN-Motoren ist das Anschlussschema der FA-Bremse wie folgt:

(F50)

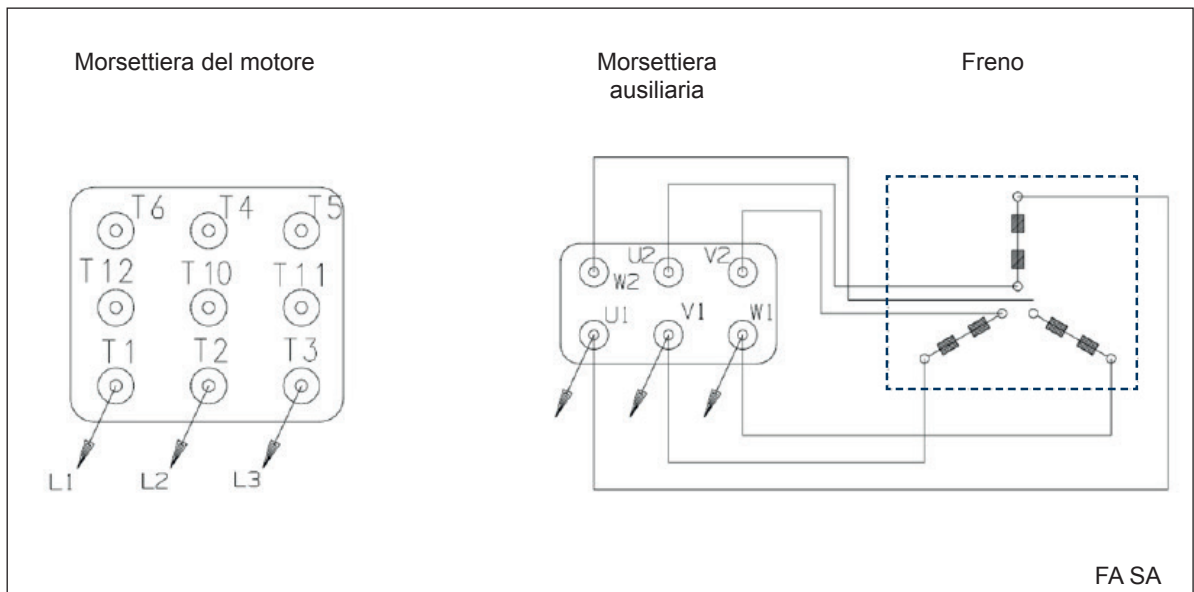

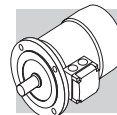

M11 BREMSLÜFTHEBEL

Für Instandhaltungsarbeiten können die Federdruckbremsen vom Typ FD und FA optional mit Bremslüfthebeln geliefert werden, um ein manuelles Lüften zu ermöglichen.

Bremslüfthebel mit automatischer Rückstellung durch Federkraft.

(F51)

R

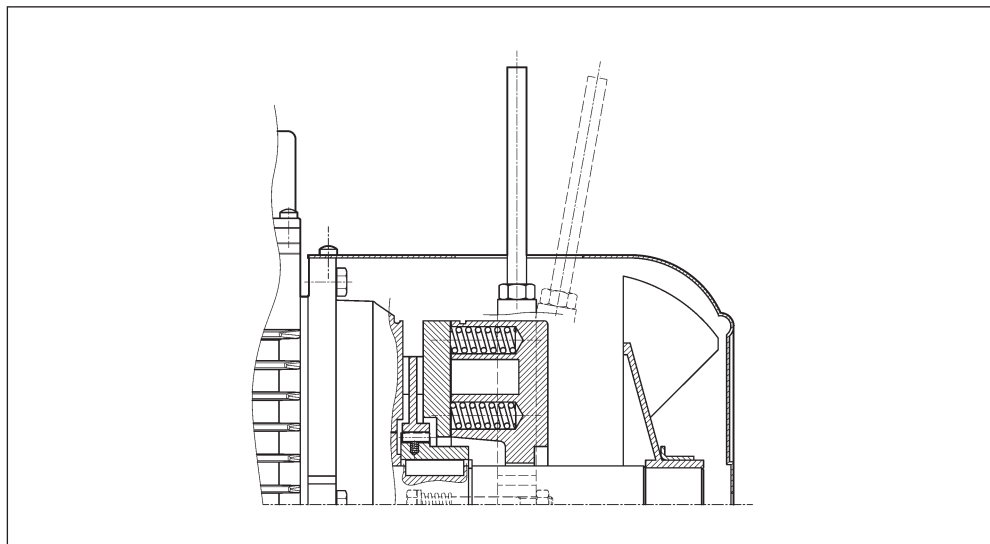

(F52)

RM

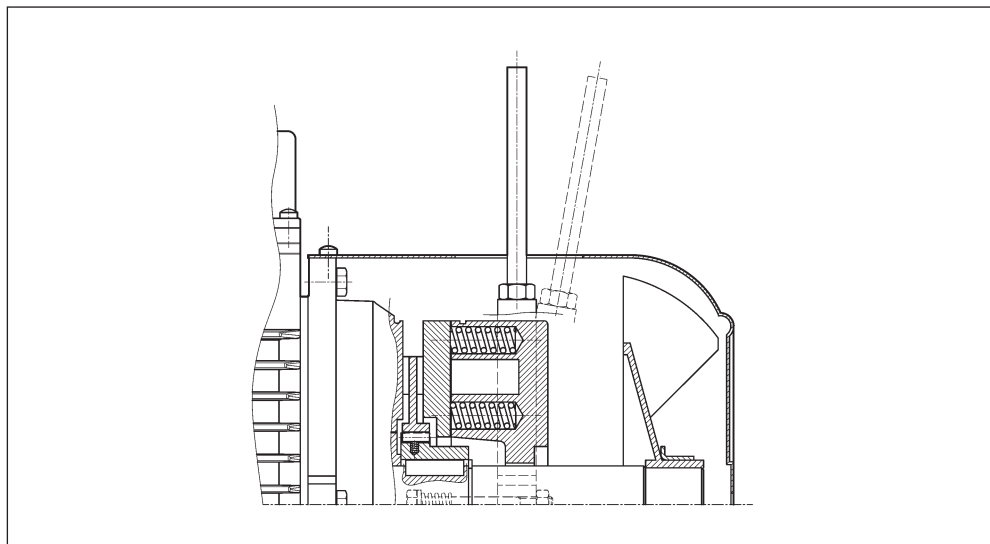

Bei Bremsmotorentyp FD mit der Option RM, kann der Bremslüfthebel bei Bedarf in der Lüfterposition arretiert werden, wenn man diesen bis zur Bremsenarretierung einschraubt.

Je nach Motortyp sind unterschiedliche Bremslüftsysteeme verfügbar, die Sie der folgenden Tabelle entnehmen können:

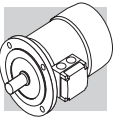

(F53)

	R	RM
BXN_FD BX_FD BE_FD BN_FD	BXN 63 ... BXN 90 BX 80 ... BX 180 BX 200K ... BX 315K BE 63 ... BE 180 BN 63 ... BN 200	BXN 63 ... BXN 90 BX 80 ... BX 132 BE 63 ... BE 132 BN 63 ... BN 132 ● FD07
MXN_FD MX_FD ME_FD M_FD	MXN05 ... MXN20 MX2 ... MX5 ME05 ... ME5 M05 ... M5	MXN05 ... MXN20 MX2 ... MX4 ME05 ... ME4 M05 ... M4LA
BXN_FA BX_FA BE_FA BN_FA	BXN 63 ... BXN 90 BX 80 ... BX 160 BE 63 ... BE 160L BN 63 ... BN 180M	●
MXN_FA MX_FA ME_FA M_FA	MXN05 ... MXN20 MX2 ... MX5 ME05 ... ME5 M05 ... M5	●

M11.1 Ausrichtung des Bremsl ufthebels

Der Bremsl ufthebel wird bei den Optionen **R** und **RM** standardm a ig um 90° im Uhrzeigersinn zur Position des Klemmkastens montiert (Position **[AB]** in der nachfolgenden Zeichnung). Andere Positionen: **AA** (0° zum Klemmkasten), **AC** (180° zum Klemmkasten) oder **AD** (270° zum Klemmkasten), im Uhrzeigersinn vom L ufer aus gesehen, k onnen auf Wunsch geliefert werden:

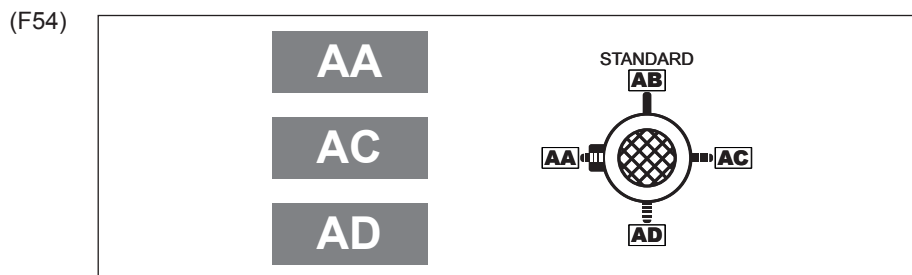

M11.2 Bremse mit separater Spannungsversorgung

DIR

Direkte Bremsversorgung

Das Bremssystem wird direkt  ber die Stromversorgung des Klemmenbretts des Elektromotors versorgt. Wenn ein  lterer Motor mit einer direkten Bremsversorgung konfiguriert ist, muss keine Option ausgewahlt werden, wahrend f ur EVOX-Motoren die DIR-Option ausgewahlt werden muss.

...SA

Separate AC-Bremsversorgung

Die Bremsspule wird direkt  ber eine unabhangige Leitung versorgt, die von der Motorleitung getrennt ist. **FA-SA**: Die Nennwechselspannung muss angegeben werden. SA 230 (VAC). **FD-NB/SB-SA**: Die Nennwechselspannung, die den Gleichrichter versorgt, muss angegeben werden. Z.B. SA 400 (VAC).

...SD

Separate DC-Bremsversorgung

Die Bremsspule wird direkt mit Gleichstrom versorgt und der Gleichrichter ist nicht vorhanden. Die Spulennennspannung muss angegeben werden, z.B. SD 24 (VDC).

Hinweis: Bei BX≥200 und BX≥200K ist es nicht m oglich, die Bremse direkt vom Motorklemmenkasten aus zu speisen, dann muss die Option SA oder SD gewahlt werden.





M12 OPTIONEN

M12.1 Sanftanlauf / stop

F1

Für Anwendungen, bei denen einer sanfte Anlauf-und Stop erforderlich ist, steht als - Option F1 - ein Schwungrad zur Verfügung, dessen zusätzliches Trägheitsmoment während der Anlaufphase kinetische Energie aufnimmt, die in der Abbremsphase wieder abgegeben wird. Dadurch erfolgen die Übergangsphasen progressiver und sanfter. Das Schwungrad ist für die Bremsmotoren vom Typ BN-BE_FD und M-ME_FD in den nachstehend aufgeführten spezifischen Details verfügbar:

(F55)

Eigenschaften der Schwungräder für Motoren typ: BN_FD, M_FD			
		Gewicht Schwungrad [Kg]	Trägheitsmoment Schwungrad [Kgm ²]
BN 63 - BE 63	M05 - ME05	0.69	0.00063
BN 71 - BE 71	M1 - ME1	1.13	0.00135
BN 80 - BE 80	M2 - ME2	1.67	0.00270
BN 90 S - BN 90 L BE 90 S - BE 90 LA	-	2.51	0.00530
BN 100 - BE 100	M3 - ME3	3.48	0.00840
BN 112 - BE 112	-	4.82	0.01483
BN 132 S - BN 132 M BE 132 S - BE 132 M	M4 - ME4	6.19	0.02580

M12.2 Kapazitiver filter

CF

Nur bei den Bremsmotoren mit vom Typ FD ist die Option eines kapazitiven Filters vorgesehen. Wird dieser Filter vor dem Gleichrichter (Option CF) installiert, fallen die Motoren in die von der Norm EN61000-6-3:2007 "Elektromagnetische Kompatibilität – Allgemeine Norm zur Emission – Teil 6-3: Wohngebiete, Handels- und Leichtinduszriezonen" vorgesehene Emissionsgrenzen.

BX \geq 200LA- und BX \geq 200LAK-Motoren erfüllen die Emissionsgrenzwerte der Norm EN 61000-6-3: 2007 "Elektromagnetische Verträglichkeit - Fachgrundnorm - Teil 6-3: Störaussendung für Wohnbereich, Geschäfts- und Gewerbebereiche sowie Kleinbetriebe"

M12.3 Thermische wicklungsschutzeinrichtungen

Standardmäßig werden Motoren durch externe Motorschutzschalter gegen Überlastung geschützt. Optional können die Motoren mit integrierten Temperaturfühlern ausgestattet werden, die die Wicklung vor Überhitzung aufgrund einer unzureichenden Luftzufuhr oder bei Aussetzbetrieb schützen. Diese Option wird auch für Motoren mit Fremdlüftung dringend empfohlen (IC416).

M12.4 PTC-Thermistoren

E3

Hierbei handelt es sich um Halbleiter, die eine schnelle Änderung des Widerstands kurz vor der Nennansprechtemperatur (150 °C) aufweisen. Der Verlauf der Kennlinie $R = f(T)$ ist durch die DIN-Normen 44081 und IEC 34-11 festgelegt. Im allgemeinen werden Thermistoren mit positivem Temperaturkoeffizienten verwendet, die unter der Bezeichnung PTC (Kaltleiter) bekannt sind. Die Thermistoren sind nicht in der Lage, die Relais direkt anzusteuern, und müssen deshalb an ein entsprechendes Auslösegerät angeschlossen werden. Die Anschlüsse der drei in den Wicklungen in Reihe geschalteten PTC-Widerstände sind an einer Zusatzklemmleiste verfügbar.



K1

Es handelt sich hierbei um eine Untergruppe der PTC-Thermistoren; ihre Baueigenschaften ermöglichen den Einsatz als Temperaturfühler, da sie einen positiven Temperaturkoeffizienten in Abhängigkeit vom Widerstand aufweisen.

Die Betriebstemperatur beträgt: 0°C ... +260°C. Die Thermistoren sind nicht in der Lage, die Relais direkt anzusteuern, und müssen deshalb an ein entsprechendes Auslösegerät angeschlossen werden. Die Anschlussklemmen (gepolt) von 1 KTY 84-130 sind in einer Hilfsklemmenleiste verfügbar.

M12.5 Bimetall-Temperaturfühler

D3

Diese Schutzeinrichtungen enthalten in einer Kapsel eine Bimetallscheibe, die bei Erreichen der Nennansprechtemperatur (150 °C) einen Schaltkontakt öffnet. Bei abnehmender Temperatur schließt dieser Kontakt wieder. Normalerweise werden die Öffnerkontakte von drei Bimetallfühlern in Reihe geschaltet und auf einer Zusatzklemmleiste zur Verfügung gestellt.

M12.6 Widerstandsthermometer

Pt1000

Das Widerstandsthermometer weist einen Chip für einen Temperatursensor auf, dessen Widerstand sich in Abhängigkeit von der Temperatur nach einer Reihe reproduzierbarer Grundwerte ändert. Die Widerstandsänderungen werden als Stromänderungen übertragen.

Bei 0°C sind die Messwiderstände beim Pt1000 auf 1000 Ohm abgeglichen und entsprechen der Genauigkeitsklasse B (also dem Verhältnis zwischen Widerstand und Temperatur). Die Grenzabweichung beträgt $\pm 0,3^\circ\text{C}$, die zulässigen Abweichungen sind in der EN 60751 definiert. Das Widerstandsthermometer Pt1000 wird zukünftig schrittweise das heute verfügbare Temperaturmessgerät KTY84-130 ersetzen. Der Zusammenhang zwischen Temperatur und elektrischem Widerstand von Leitern wird beim Pt1000 zur Temperaturmessung ausgenutzt, ebenso wie bei den oben beschriebenen Zusatz-Widerstandsthermometern. Reine Metalle unterliegen größeren Widerstandsänderungen als Legierungen und haben einen relativ konstanten Temperaturkoeffizienten.

M12.7 Motor mit Verbinder

CON

Es stehen drei Verbindertypen (CON 1, CON 2, CON 3) zur Verfügung, die in zwei Einbaupositionen installiert werden können: rechte Seite des Klemmenkastens (C1D, C2D, C3D); linke Seite des Klemmenkastens (C1S, C2S, C3S). Die CON-Option steht für die BN und M-Motoren mit einzelner Polarität (2, 4, 6, 8 Pole) und BX/BE und MX/ME je nach Größe wie in der folgenden Liste beschrieben zur Verfügung. Alle polumschaltbaren Motoren sind ausgenommen. Die Verbinder sind für die BX-BE/MX-ME und BN/M in der Version ohne Bremse und für die Bremsmotoren mit Gleichstrombremse FD in den Größen gemäß nachstehender Tabelle erhältlich.

Am Motor ist der (Stecker-) Verbinder (mit Stiften) befestigt, während der (Buchsen-) Verbinder nicht zum Lieferumfang zählt. Mit der CON-Option ist stets der Y-Anschluss der Phasen vorgesehen. Für die Fremdlüftermotoren (Option U1) ist der Anschluss zur Versorgung des Lüfters im separaten, an der Lüfterabdeckung befestigten Klemmenkasten vorgesehen. Bei den Motoren mit Encoder (Optionen EN1...EN6) erfolgt der Anschluss des Encoders mit einem losen Kabel, das nicht am Verbinder angeschlossen ist.

Die CON-Option ist für die Motoren mit Wechselstrombremse FA nicht anwendbar.

Die CON-Option ist für Optionen U2, CUS, IC nicht kompatibel.



Technische Daten

(F56)

Option	CON 1
Motor-Baugrosse	BX 80 ... BX 112 / MX2, MX3 / BE 63 ... BE 112 / ME05 ... ME4 BN 63 ... BN 112 / M05 ... M3
Ansicht des Verbinders	
Verbindertyp	Harting Han 10ES
Verbindergehäuse	Han EMC 10B mit 2 Hebeln
Stiftanzahl - Nennstrom	10 x 16A
Versorgungsspannung	500 Vac
Anschlussart der Kontakte	Schraubklemmen

(F57)

Option	CON 2
Motor-Baugrosse	BX 80 ... BX 132 / MX2, MX3 / BE 63 ... BE 132 / ME05 ... ME4 BN 63 ... BN 160MR / M05 ... M4
Ansicht des Verbinders	
Verbindertyp	Harting Han Modular
Verbindergehäuse	Han EMC 10B mit 2 Hebeln
Modultyp	Modul C + Leeres Modul + Modul E
Stiftanzahl - Nennstrom	3 x 36A / 6 x 16A
Versorgungsspannung	500 Vac
Anschlussart der Kontakte	Crimpkontakte

(F58)

Option	CON 3
Motor-Baugrosse	BX 80 ... BX 132M / MX2, MX3 / BE 63 ... BE 132 / ME05 ... ME4 / BN 63 ... BN 160MR / M05 ... M4
Ansicht des Verbinders	
Verbindertyp	Harting Han Modular
Verbindergehäuse	Han EMC 10B mit 2 Hebeln
Modultyp	Modul C + Modul E + Modul E
Stiftanzahl - Nennstrom	3 x 36A / 6 + 6 x 16A
Versorgungsspannung	500 Vac
Anschlussart der Kontakte	Crimpkontakte

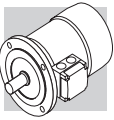

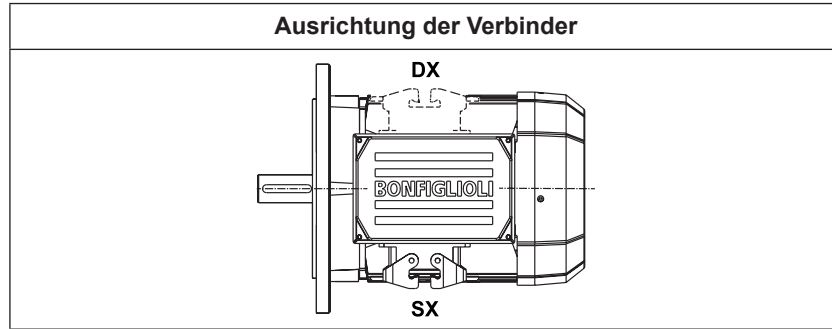

(F59)



(F60)



Abmessungen der Motoren ohne Bremse

		AD (mm)	AF (mm)	AH (mm)	LL (mm)	V ^(*) (mm)
BE 63 - BN 63	ME05 - M05	136	110	45	165	4.5
BE 71 - BN 71	ME1 - M1	149	110	45	165	15.5
BX 80 - BE 80 - BN 80	MX2 - ME2 - M2	160	110	45	165	16.5
BX 90 - BE 90 - BN 90	MX3	162	110	45	165	31.5
BX 100 - BE 100 - BN 100	MX3 - ME3 - M3	171	110	45	165	37.5
BX 112 - BE 112 - BN 112	MX4	186	110	45	165	39
BX 132 - BE 132 - BN 132	MX4 - ME4 - M4	210	140	45	188	45.5
BN 160MR	—	210	140	45	188	161

(*) Dimension gilt nur für Motoren BX, BE und BN.

(F61)

Abmessungen der Motoren mit FD-Bremse

		AD (mm)	AF (mm)	AH (mm)	LL (mm)	V ^(*) (mm)
BE 63 - BN 63	ME05 - M05	136	110	45	165	4.5
BE 71 - BN 71	ME1 - M1	149	110	45	165	1.5
BX 80 - BE 80 - BN 80	MX2 - ME2 - M2	160	110	45	165	18.5
BX 90 - BE 90 - BN 90	—	162	110	45	165	39.5
BX 100 - BE 100 - BN 100	MX3 - ME3 - M3	171	110	45	165	63.5
BX 112 - BE 112 - BN 112	—	186	110	45	165	75
BX 132 - BE 132 - BN 132	MX4 - ME4 - M4	210	140	45	188	122
BN 160MR	—	210	140	45	188	161

(*) Dimension gilt nur für Motoren BX und BN.

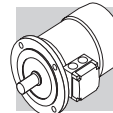

M12.8 Kontrolle der Funktionstüchtigkeit der Bremse

MSW

Der Mikroschalter kann entsprechend eingestellt werden, um das Anziehen / Lösen des beweglichen Ankers oder das Erreichen des zulässigen Höchstwerts für den Luftspalt zu melden.

Die MSW-Option ist für die Bremsen FD03...FD09 verfügbar.

Der Mikroschalter ist mit drei Anschlussklemmen NC, NO, COM versehen. In der nachfolgenden Zeichnung sind die wesentlichen Komponenten der mit Mikroschalter ausgestatteten Bremse dargestellt.

(F62)

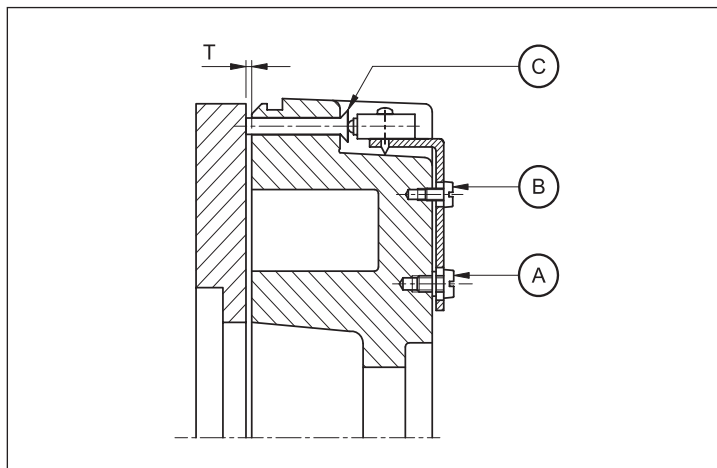

- A: Befestigungsschrauben
- B: Einstellschraube
- C: Antrieb

M12.9 Zusätzlicher Kabeleingang für Bremsmotoren

IC

Am Klemmenkasten der Bremsmotoren BN 63 ... BN 160MR - M05 ... M4L sind zwei zusätzliche Kabeleingänge M16 x 1,5 verfügbar (einer pro Seite).

Am Klemmenkasten der Bremsmotoren BN 160 ... BN 200 - M5 ist ein zusätzlicher Kabeleingang M16 x 1,5 neben dem Eingang des Bremskabels verfügbar.

M12.10 Wicklungsheizung

H1

NH1

Die Motoren, die in besonders feuchten Umgebungen und/oder unter starken Temperaturschwankungen eingesetzt werden, können mit einem Heizelement als Kondenswasserschutz ausgestattet werden.

Die einphasige Versorgung erfolgt über eine Zusatzklemmleiste, die sich im Klemmkasten befindet. Werte fuer die Leistungsaufnahme sind in folgender Tabelle aufgeführt.

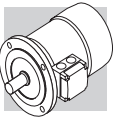

(F63)

	H1	NH1
	1~ 230V ± 10% P [W]	1~ 115V ± 10% P [W]
BXN 63 ... BXN 80 BX 80 BE 63 ... BE 80 BN 56 ... BN 80	10	10
BXN 90 BX 90 ... BX 132 BE 90 ... BE 132MB BN 90 ... BN 160MR	25	25
BX 160...BX 250 BX 160 ... BX 250K BX 160, BX 180 BE 160, BE 180 BN 160, BN 200	50	50
BX 280 BX 280K	60	60
BX 315 ... BX 355 BX 315K ... BX 355K	120	120

Warnung!

Während des Motorbetriebs darf die Wicklungsheizung nie in Betrieb sein.

M12.11 Tropenschutz

TP

Wird die Option **TP** bestellt, wird die Motorwicklung mit einem zusätzlichen Schutz ausgestattet, der ihren Einsatz unter hohen Temperaturen und starker Feuchtigkeit ermöglicht.

M12.12 Zweites Wellenende

PS

Diese Option schließt die Optionen RC, TC, U1, U2, EN1, EN2, EN3, EN4, EN5, EN6, EN7, EN8. Die entsprechenden Abmessungen können den Maßtabellen der Motoren entnommen werden.

(F64)

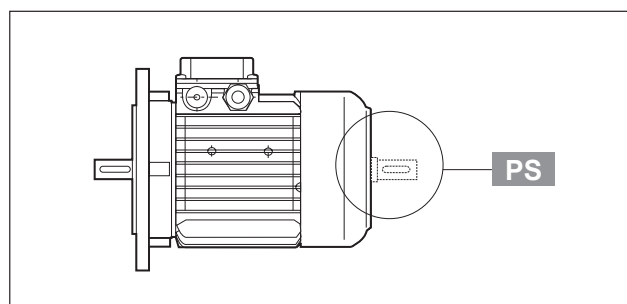



M12.13 Rücklaufsperr

AL

AR

Wenn ein durch die Last verursachtes Zurückdrehen des Motors verhindert werden soll, kann eine Rücklaufsperr integriert werden (nur bei Serie MX/ME und M verfügbar). Diese Vorrichtung, die eine völlig ungehinderte Drehung des Motors in Laufrichtung gestattet, greift sofort ein, wenn die Spannung fehlt, und verhindert die Drehung der Welle in die Gegenrichtung.

Die Rücklaufsperr verfügt über eine Dauerschmierung mit einem speziell für diese Anwendung geeignetem Fett. Bei der Bestellung muss die vorgesehene Drehrichtung des Motors angegeben werden. Die Rücklaufsperr darf keinesfalls verwendet werden, um im Falle eines fehlerhaften elektrischen Anschlusses die Drehung in die Gegenrichtung zu verhindern. In Tabelle (F62) sind die Nenn- und Höchstdrehmomente für die verwendeten Rücklaufsperr angegeben; Abbildung (F63) zeigt eine schematische Darstellung der Vorrichtung. Die Abmessungen sind ähnlich denen der Bremsmotoren. Die Richtungsangabe der freien Rotation ist in dem Getriebeteil des Katalogs unter dem Abschnitt „OPTIONEN MOTOREN“ beschrieben.

(F65)

	Nenn Drehmoment der Sperre [Nm]	Max. Drehmoment der Sperre [Nm]	Ausrückgeschwindigkeit [min ⁻¹]
ME1 - M1	6	10	750
MX2 - ME2 M2	16	27	650
MX3 - ME3 M3	54	92	520
MX4 - ME4 M4	110	205	430

(F66)

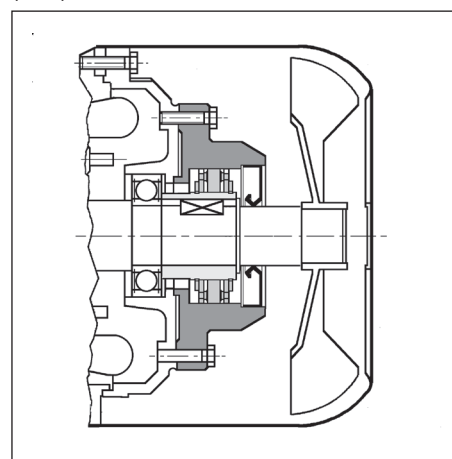

M12.14 Rotorauswuchtung

RV

Sollte eine besondere Laufruhe gefordert werden, steht als Option RV eine Ausführung mit reduziertem Schwingverhalten nach Grad B, zur Verfügung.

Die folgende Tabelle gibt die Werte der effektive Schwingungen für das normale Auswuchten (A) und im Grad B an.

(F67)

Vibrationlevel	Winkelgeschwindigkeit n [min ⁻¹]	Grenzen der Schwingungsstärke (mm/s) BX 80 ≤ H ≤ BX 335M ≤ BX 355MK BE 63 ≤ H ≤ BE 180L BN 56 ≤ H ≤ BN 200
A	600 < n < 3600	1.6
B	600 < n < 3600	0.70

Diese Werte beziehen sich auf einem frei hängenden und sich im Leerbetrieb befindlichen Motor; Toleranz ±10%.



M12.15 Belüftung

Die Motoren werden mittels Eigenbelüftung gekühlt (IC 411 gemäss CEI EN 60034-6) und sind mit einem Radiallüfterrad aus Kunststoff ausgestattet, welches in beiden Drehrichtungen wirksam ist. Bei der Montage des Motors muss darauf geachtet werden, dass zwischen Lüfterhaube und dem nächsten Bauteil ein Mindestabstand eingehalten wird, um die Luftzirkulation nicht zu beeinträchtigen. Dieser Abstand ist ebenso für die regelmäßige Wartung des Motors und, falls vorhanden, der Bremse erforderlich. Die Kühlung erfolgt hier durch einen Axialventilator, der an Stelle der Standardlüfterhaube (Kühlmethode IC 416) montiert wird.



Diese Ausführung sollte eingesetzt werden, falls der Motor über einen Frequenzumrichter auch bei kleinen Drehzahlen mit Nennmoment betrieben wird oder bei hoher Schalzhäufigkeit.

Von dieser Option ausgeschlossen sind die Motoren mit zweitem Wellenende (Option PS).

Für diese Option sind als Alternative zwei Ausführungen verfügbar: **U1** und **U2** mit gleichen Längenmaßen. Für beide Ausführungen wird die Verlängerung der Lüfterhaube (**DL**) in der nachstehenden Tabelle angegeben.

Die Gesamtmaße der Motoren können den Tabellen mit den Motormaßen entnommen werden.

(F68)

Tabelle - Motorverlängerung			
		ΔL_1	ΔL_2
BE 71 - BN 71	ME1 - M1	93	32
BX 80	MX2	80	67
BE 80 - BN 80	ME2 - M2	125	55
BX 90	—	133	85
BE 90 - BN 90	—	133	49
BX 100	MX3	135	88
BE 100 - BN 100	ME3 - M3	119	30
BX 112	—	136	90
BE 112 - BN 112	—	130	33
BX 132	MX4	123	24
BE 132 - BN 132	ME4 - M4	160	51
BX 160 - BX 180	MX5	184	184
BE 160 - BE 180	ME5		
BN 160 - BN 180 - BN 200	M5		
BX 200	—	260	260
BX 225 - BX 250	—	320	320
BX 280 - BX 315	—	430	430
BX 355	—	640	640

ΔL_1 = Maßänderung gegenüber Maß LB des entsprechenden Standardmotors.

ΔL_2 = Maßänderung gegenüber Maß LB des entsprechenden Bremsmotors.

Nur für Motoren BN.

U1

Versorgungsanschlüsse des Ventilators befinden sich im Zusatzklemmkasten.

Bei den Bremsmotoren in der Baugröße BX 132 ... BX 160 - BE 71 ... BE 160 - BN 71 ... BN 160MR, MX4, MX5 - ME05 ... ME5 - M05 ... M5 mit Option **U1**, kann der Bremslüfthebel nicht in der Position AA stehen.

Diese Option kann für Motoren ausgewählt werden, die den CSA und UL Standards entsprechen (CUS-Option), nur für BX \geq 200 und BX \geq 200K.



(F69)

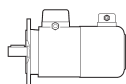

			V a.c. ±10%	Hz	P [W]	I [A]
BN 71 - BE 71	ME1 - M1		1 ~ 230	50 / 60	22	0.12
BX 80 - BE 80 BN 80	MX2 - ME2 M2				22	0.12
BX 90 - BE 90 BN 90	—				40	0.30
BX 100 - BE 100 BN 100	MX3 - ME3 M3				50	0.25
BX 112 - BE 112 BN 112	—		3 ~ 230Δ / 400Y	50	50	0.26 / 0.15
BX 132 - BE 132 BN 132 ... BN 160MR	MX4 - ME4 M4L				110	0.38 / 0.22
BX 160 - BE 160 BN 160M ... BN 180M	MX5 - ME5 M5				180	1.25 / 0.72
BX 180 - BE 180 BN 180L ... BN 200L	—		3 ~ 400Δ / 690Y	50	250	1.51 / 0.87
BX 200 ... BX 250 BX 200K ... BX 250K	—				250	0.64
BX 280 ... BX 315M BX 280K ... BX 315MK	—				750	1.7
BX 315 ... BX 355S BX 315LK ... BX 355SK	—				1500	3.3
BX 355M BX 355MK	—				3000	6.1

U2

Versorgungsanschlüsse des Ventilators befinden sich im Hauptklemmkasten des Motors.

Die Option **U2** ist nicht verfügbar für die Motoren BX, BE, MX, ME und nicht für Motoren mit CUS-Option (entsprechend den Normen CSA und UL).

(F70)

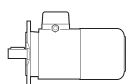

			V a.c. ±10%	Hz	P [W]	I [A]
BN 71	M1		1 ~ 230	50 / 60	22	0.12
BN 80	M2				22	0.12
BN 90	—				40	0.30
BN 100	M3		3 ~ 230Δ / 400Y	50	40	0.26 / 0.09
BN 112	—				50	0.26 / 0.15
BN 132 ... BN 160MR	M4L				110	0.38 / 0.22



M12.16 Regenschutzdach

RC

Das Regenschutzdach RC wird empfohlen, wenn der Motor senkrecht mit einer nach unten gerichteten Welle montiert wird. Es dient dem Schutz des Motors vor dem Eindringen von festen Fremdkörpern und Tropfwasser. Die Abmessungen werden in der folgende Tabelle angegeben. Die Schutzdachoption schließt die Möglichkeit der Optionen PS, EN1, EN2, EN3, EN4, EN5, EN6.



(F71)

		AQ	ΔV
BE 63 - BN 63	ME05 - M05	118	24
BN 71 - BE 71	ME1 - M1	134	27
BX 80 - BE 80 BN 80	MX2 - ME2 M2	152	25
BX 90 - BE 90 BN 90	—	168	30
BX 100 - BE 100 BN 100	MX3 - ME3 M3	190	28
BX 112 - BE 112 BN 112	—	211	32
BX 132 - BE 132 BN 132 ... BN 160MR	MX4 - ME4 M4	254	32
BX 160 - BE 160 BN 160M ... BN 180M	MX5 - ME5 M5	302	36
BX 180 - BE 180 BN 180L ... BN 200L	—	340	36
BX 200	—	423	55
BX 225	—	465	55
BX 250	—	514	55
BX 280	—	567	100
BX 315	—	645	100
BX 355	—	740	120

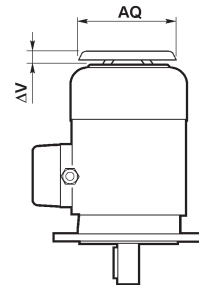

Für RC/TC auf BXN/MXN-Motoren siehe Schema unten.

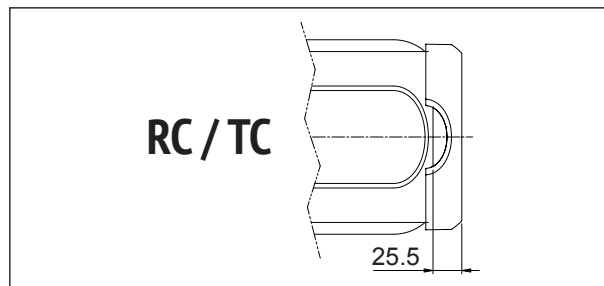

M12.17 Textilschutzdach

TC

Bei der Option TC handelt es sich um ein Schutzdach mit einem Textilnetz, dessen Einsatz empfohlen wird, wenn der Motor in Bereichen der Textilindustrie installiert wird, in denen Stofffusseln das Lüfterradgitter verstopfen und so einen ausreichenden Kühlluftfluss verhindern könnten. Diese Option schließt die Möglichkeit der Optionen EN1, EN2, EN3, EN4, EN5, EN6, PS, U1, U2. Die Gesamtmaße entsprechen denen des Schutzdachs vom Typ RC. TC Option ist nicht für BX Motoren verfügbar.

M12.18 Drehgeberanschluss

Die Motoren können mit sechs unterschiedlichen Encodertypen ausgestattet werden. Nachstehend finden Sie die entsprechenden Beschreibungen. Die Montage eines Encoders schließt die Version mit zweitem Wellenende (PS) und Schutzdach (RC, TC) aus.



EN1

Inkremental-Encoder, $V_{IN} = 5\text{ V}$, Ausgang „line-driver“ RS 422.

EN2

Inkremental-Encoder, $V_{IN} = 10\text{-}30\text{ V}$, Ausgang „line-driver“ RS 422

EN3

Inkremental-Encoder, $V_{IN} = 12\text{-}30\text{ V}$, Ausgang „push-pull“ 12-30 V

EN4

Encoder sin/cos, $V_{IN} = 4,5\text{-}5,5\text{ V}$, Sinus-Ausgang $0,5\text{ V}_{PP}$.

EN5

Absolut-Encoder mit Einzelwindung, Schnittstelle HIPERFACE®, $V_{IN} = 7\text{-}12\text{ V}$.

EN6

Absolut-Encoder mit Mehrfachwindung, Schnittstelle HIPERFACE®, $V_{IN} = 7\text{-}12\text{ V}$.

EN7

Inkrementeller Heavy Duty-Encoder, $V_{IN} = 12\text{-}30\text{ V}$, Push-Pull Ausgang 12-30 V.

EN8

Inkrementeller Hochleistungscodierer, $V_{IN} = 12\text{-}30\text{ V}$, Push-Pull Ausgang 9-30 V.

Hinweise: EN7 und EN8 nur für $BX \geq 200$ verfügbar

(F72)

	EN1	EN2	EN3	EN4	EN5	EN6	EN7	EN8	
Schnittstelle	TTL/RS 422	TTL/RS 422	HTL push-pull	Sinus 0.5 VPP	HIPERFACE®	HIPERFACE®	HTL push-pull	HTL push-pull	
Versorgungsspannung [V]	4...6	10...30	12...30	4.4...5.5	7...12	7...12	9...30		
Ausgangsspannung [V]	5	5	12...30	—	—	—	9...30		
Betriebsstrom ohne Belastung [mA]	120	100	100	40	80	80	80		
Impulse pro Drehung	1024							2048	
Positionen pro Umdrehung	—	—	—	—	15 bit	15 bit	-	-	
Revolutionen	—	—	—	—	—	12 bit	-	-	
Signale	6 (A, B, Z + invertierte Signale)			6 (cos-, cos+, sin-, sin+, Z, Z̄)	—	—	6	6	
Max. Ausgangsfrequenz [kHz]	600			200			200		
Max. Drehzahl [min ⁻¹]	6000 (9000 min ⁻¹ für 10 s)							6000	
Temperaturbereich [°C]	-30 ... +100						-20 ... +85		
Schutzgrad	IP 65						IP67		

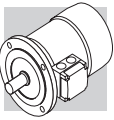

(F73)

EN1, EN2, EN3, EN4, EN5, EN6, EN7, EN8		
		L4
BN 63 ... BN 200	M05 ... M5	65
BE 63... BE180	ME05 ... ME5L	65
BX 80 ... BX 180	MX2 ... MX5L	65
BX 200 ... BX 280	—	100
BX 315 ... BX 355	—	100

(F74)

EN_ + U1		
		L3
BX 160 - BE 160 BN 160M...BN 180M	MX5 - ME5 M5	72
BX 160 - BE 180 BN 180L...BN 200L	—	82
BX 160_FD BN 160M_FD...BN 180M_FD	MX5_FD M5_FD	35
BX 180_FD BN 180L_FD...BN 200L_FD	—	41
BX 200 - BX 225 - BX 250	—	100
BX 280 - BX 315 - BX 355	—	150

Wenn der Encoder (Option EN_) für Motoren der Baugrößen BX 80 ... BX 132 - MX2 ... MX4 - BE 63 ... BE 132 - ME05 ... ME4 - BN 71 ... BN 160MR - M1 ... M4 zusammen mit Fremdlüftung (Optionen U1, U2) ausgelegt ist, stimmen die Maßänderungen des Motors mit jenen der entsprechenden Ausführungen U1 und U2 überein.

Für EN auf BXN/MXN-Motoren siehe Schema unten.

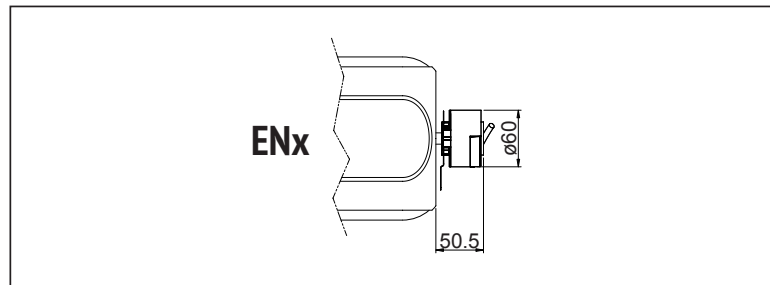

M12.19 EC - Encoder-Überdachung

EC

Option EC ist eine Abdeckungsvariante speziell für unsere Drehgeber. Es schützt sie vor Stößen und kann dazu beitragen, ihre produktive Lebensdauer zu verlängern.

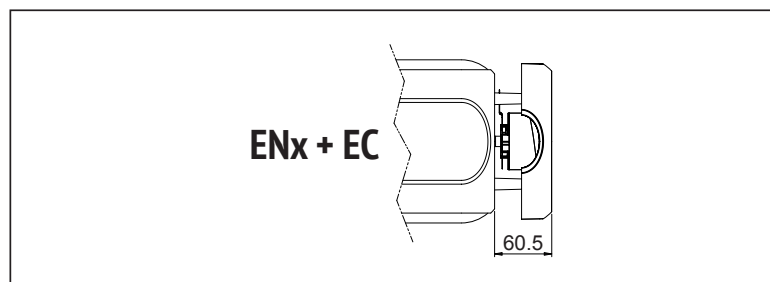



M12.20 Isolierte Lager

IB

HINWEIS: Diese Option ist für BX und BX K \geq 280 verfügbar. Sie ist obligatorisch, wenn der Motor über einen Frequenzumrichter betrieben wird.

Bei Auswahl der Option IB ist der Motor auf der Antriebsseite mit isolierten Lagern ausgestattet. Dies verhindert frühe Lagerausfälle aufgrund von Hochfrequenzzirkulationsströmen.

M12.21 Vertikale Montage

VM

HINWEIS: Diese Option ist für BX \geq 200 und BX \geq 200K vorgegeben, wenn sie vertikal montiert werden.

Wenn VM ausgewählt ist, wird der Motor mit speziellen Anpassungen geliefert.

Außerdem wird die vertikale Einbaulage auch auf dem Motortypenschild angegeben.

M12.22 Oberflächenschutz

C_

Wenn keine besondere Korrosionsschutzklasse gefordert ist, ist die lackierte Oberfläche des Motoren mindestens mit einem Schutz gegen Korrosion der Klasse C2 nach UNI EN ISO 12944-2 geschützt. Für eine bessere Witterungsbeständigkeit können die Motor durch eine Lackierung mit einem Oberflächenschutz der Klassen C3 und C4 geliefert werden.

(F75)

OBERFLÄCHEN-SCHUTZ	Typische Umgebungen	Maximale Oberflächen-temperatu	Korrosionsschutzklasse nach UNI EN ISO 12944-2
C3	Stadt- und Industrieumgebung mit bis zu 100% relativer Luftfeuchtigkeit (mittlere Luftverschmutzung)	120°C	C3
C4	Industrie- und Küstengebiete und Chemieanlagen mit bis zu 100% relativer Luftfeuchtigkeit (hohe Luftverschmutzung)	120°C	C4
C5M	Küsten- und Offshore-Gebiete mit hohem Salzgehalt.	120°C	C5M

Die Motoren mit einem optionalen Korrosionsschutz der Klassen C3 oder C4 sind in einer Auswahl von Farben verfügbar. Wenn keine spezielle Farbe gefordert ist, (siehe Option „Lackierung“) ist der Decklack in RAL 7042 für BN/M, BE/ME und BX \leq 180/MX und in Munsellblau 8B 4,5 / 3,25 für BX \geq 200. Unsere Motor können auch mit Oberflächenschutz der Klasse C5 nach UNI EN ISO 12944-2 versehen werden. Für weitere technische Informationen wenden Sie bitte an unseren Technischen Service.



M12.23 Lackierung

RAL

Die Motoren mit Oberflächenschutz der Klasse C3 oder C4, sind in den, in der folgenden Liste aufgelisteten Farben, verfügbar.

(F76)

LACKIERUNG	Colour	RAL Nummer
RAL7042	Traffic Grey A	7042
RAL5010	Gentian Blue	5010
RAL9005	Jet Black	9005
RAL9006	White Aluminium	9006
RAL9010	Pure White	9010
Munsell blue 8B* 4.5/3.25	Blue	MUNSELL 8B 4.5/3.25
RAL7035	Light grey	7035
RAL7001	Silver gray	7001
RAL5015	Sky blue	5015
RAL7037	Dusty gray	7037
RAL5024	Pastel blue	5024

* BX \geq 200 und BX \geq 200K Motoren werden standardmäßig in dieser Farbe mit C3-Korrosionsschutz geliefert, sofern nicht anders angegeben.

Hinweis – Die Option “Lackierung” kann nur im Zusammenhang mit dem Oberflächenschutz spezifiziert werden.

M12.24 Nachweise

ACM

Konformitätsbescheinigung von Motoren Dokument mit dessen Ausstellung die Konformität des Produkts mit dem Auftrag, und dessen Konstruktion in Konformität mit den vom Qualitätsmanagementsystem von Bonfiglioli Riduttori vorgesehenen Standardfertigungs- und -kontrollverfahren bescheinigt wird.

Hinweis: Nicht verfügbar für BX \geq 200 und BX \geq 200K

CC

Prüfzeugnis



Die Bestellung führt zur Durchführung von Kontrollen der Konformität mit dem Auftrag, allgemeinen Sichtkontrollen und instrumentalen Prüfung der elektrischen Eigenschaften in unbelasteten Bedingungen. Die Prüfung wird anhand einer Stichprobe des Versandloses durchgeführt.





M13 TABELLE MOTORZUORDNUNG

M13.1 50 Hz Motoren

(F77)

2 poligen							
Wirkungsgradklasse	IE1	IE2	IE3	IE1	IE2	IE3	
Pn [kW]	0.06						
	0.09						
	0.12						
	0.18	BN 63A 2			M 05A 2		
	0.25	BN 63B 2			M 05B 2		
	0.37	BN 71A 2			M 05C 2		
	0.55	BN 71B 2			M 1SD 2		
	0.75	BN 71C 2 BN 80A 2	BE 80A 2		M 1LA 2	ME 2SA 2	
	1.1	BN 80B 2	BE 80B 2		M 2SA 2	ME 2SB 2	
	1.5	BN 90SA 2	BE 90SA 2		M 2SB 2		
	1.85	BN 90SB 2					
	2.2	BN 90L 2	BE 90L 2		M 3SA 2		
	3	BN 100L 2	BE 100L 2		M 3LA 2	ME 3LB 2	
	4	BN 112M 2	BE 112M 2		M 3LB 2		
	5.5	BN 132SA 2	BE 132SA 2		M 4SA 2	ME 4SA 2	
	7.5	BN 132SB 2	BE 132SB 2		M 4SB 2	ME 4LA 2	
	9.2	BN 132M 2	BE 132MB 2		M 4LA 2	ME 4LB 2	
	11	BN 160MR 2 BN 160M 2	BE 160MA 2		M 4LC 2	ME 5SA 2	
	15	BN 160MB 2	BE 160MB 2		M 5SB 2	ME 5SB 2	
	18.5	BN 160L 2	BE 160L 2		M 5SC 2	ME 5LA 2	
22	BN 180M 2			M 5LA 2			
30	BN 200LA 2						



(F78)

4 poligen								
Wirkungsgradklasse	IE1	IE2	IE3	IE1	IE2	IE3		
Pn [kW]	0.06	BN 56A 4						
	0.09	BN 56B 4			M 0B 4			
	0.12	BN 63A 4	BE 63A 4	BXN 63MA 4	M 05A 4	ME 05A 4	MXN 05MA 4	
	0.18	BN 63B 4	BE 63B 4	BXN 63MB 4	M 05B 4	ME 05B 4	MXN 05MB 4	
	0.25	BN 63C 4			M 05C 4			
	0.37	BN 71A 4	BE 71A 4	BXN 71MA 4	M 05C 4	ME 1SA 4	MXN 10MA 4	
	0.37	BN 71B 4	BE 71B 4	BXN 71MB 4	M 1SD 4	ME 1SB 4	MXN 10MB 4	
	0.55	BN 71C 4						
	0.55	BN 80A 4	BE 80A 4	BXN 80MA 4	M 1LA 4		MXN 20MA 4	
	0.75	BN 80B 4	BE 80B 4	BX 80B 4	BXN 80MB 4	M 2SA 4	ME 2SB 4	MX 2SB 4
	1.1	BN 80C 4 BN 90S 4	BE 90S 4	BX 90S 4	BXN 90S 4	M 2SB 4	ME 3SA 4	MX 3SA 4
	1.5	BN 90LA 4	BE 90LA 4	BX 90LA 4	BXN 90L 4	M 3SA 4	ME 3SB 4	MX 3SB 4
	1.85	BN 90LB 4						
	2.2	BN 100LA 4	BE 100LA 4	BX 100LA 4		M 3LA 4	ME 3LA 4	MX 3LA 4
	3	BN 100LB 4	BE 100LB 4	BX 100LB 4		M 3LB 4	ME 3LB 4	MX 3LB 4
	4	BN 112M 4	BE 112M 4	BX 112M 4		M 3LC 4	ME 4SA 4	MX 4SA 4
	5.5	BN 132S 4	BE 132S 4	BX 132SB 4		M 4SA 4	ME 4SB 4	MX 4SB 4
	7.5	BN 132MA 4	BE 132MA 4	BX 132MA 4		M 4LA 4	ME 4LA 4	MX 4LA 4
	9.2	BN 132MB 4	BE 132MB 4	BX 160MA 4		M 4LB 4	ME 4LB 4	MX 5SA 4
	11	BN 160MR 4 BN 160M 4	BE 160M 4	BX 160MB 4		M 4LC 4	ME 5SA 4	MX 5SB 4
	15	BN 160L 4	BE 160L 4	BX 160L 4		M 5SB 4	ME 5LA 4	MX 5LA 4
	18.5	BN 180M 4	BE 180M 4	BX 180M 4		M 5LA 4		
	22	BN 180L 4	BE 180L 4	BX 180L 4				
	30	BN 200L 4		BX 200LA 4*				
	37			BX 225SA 4*				
	45			BX 225SB 4*				
	55			BX 250MA 4*				
	75			BX 280SA 4*				
	90			BX 280SB 4*				
	110			BX 315SA 4*				
132			BX 315SB 4*					
160			BX 315SC 4*					
200			BX 315MA 4*					
250			BX 355MA 4*					
315			BX 355MB 4*					
355			BX 355MC 4*					

Hinweis: Für den australischen Markt müssen diese Motoren in der Version BX...K 4 ausgewählt werden





(F79)

6 poligen							
Classe de rendement	IE1	IE2	IE3	IE1	IE2	IE3	
Pn [kW]	0.06						
	0.09	BN 63A 6			M 05A 6		
	0.12	BN 63B 6			M 05B 6		
	0.18	BN 71A 6			M 1SC 6		
	0.25	BN 71B 6			M 1SD 6		
		BN 71C 6					
	0.37	BN 80A 6			M 1LA 6		
	0.55	BN 80B 6			M 2SA 6		
	0.75	BN 80C 6	BE 90S 6		M 2SB 6		
		BN 90S 6					
	1.1	BN 90L 6	BE 100M 6		M 3SA 6	ME 3LA 6	
	1.5	BN 100LA 6	BE 100LA 6		M 3LA 6	ME 3LB 6	
	1.85	BN 100LB 6			M 3LB 6		
	2.2	BN 112M 6	BE 112M 6		M 3LC 6		
	3	BN 132S 6	BE 132S 6		M 4SA 6	ME 4SB 6	
	4	BN 132MA 6	BE 132MA 6		M 4LA 6	ME 4LA 6	
	5.5	BN 132MB 6	BE 160MA 6		M 4LB 6	ME 5SA 6	
	7.5	BN 160M 6	BE 160MB 6		M 5SA 6	ME 5SB 6	
	9.2						
11	BN 160L 6			M 5SB 6			
15	BN 180L 6						
18.5	BN 200LA 6						
22							
30							



M13.2 60 Hz Motoren

(F80)



2 poligen							
Wirkungsgradklasse	IE1	IE2	IE3	IE1	IE2	IE3	
Pn [kW]	0.06						
	0.09						
	0.12						
	0.18	BN 63A 2			M 05A 2		
	0.25	BN 63B 2			M 05B 2		
	0.37	BN 71A 2			M 05C 2		
	0.55	BN 71B 2			M 1SD 2		
		BN 71C 2					
	1.1	BN 80A 2			M 1LA 2		
		BN 80B 2					
	1.5	BN 90SA 2			M 2SA 2		
	1.85	BN 90SB 2			M 2SB 2		
	2.2	BN 90L 2			M 3SA 2		
	3	BN 100L 2			M 3LA 2		
	3.7	BN 112M 2			M 3LB 2		
	5.5	BN 132SA 2			M 4SA 2		
	7.5	BN 132SB 2			M 4SB 2		
	9.2	BN 132M 2			M 4LA 2		
	11	BN 160MR 2			M 4LC 2		
		BN 160M 2					
15	BN 160MB 2			M 5SB 2			
18.5	BN 160L 2			M 5SC 2			
22	BN 180M 2			M 5LA 2			
30	BN 200LA 2						



(F81)



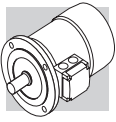

4 poligen								
Wirkungsgradklasse	IE1	IE2	IE3		IE1	IE2	IE3	
Pn [kW]	0.06	BN 56A 4						
	0.09	BN 56B 4			M 0B 4			
	0.12	BN 63A 4	BE 63A 4		BXN 63MA 4	M 05A 4	MXN 05MA 4	
	0.18	BN 63B 4	BE 63B 4		BXN 63MB 4	M 05B 4		MXN 05MB 4
		BN 63C 4						
	0.25	BN 71A 4	BE 71A 4		BXN 71MA 4	M 05C 4		MXN 10MA 4
		BN 71B 4	BE 71B 4		BXN 71MB 4	M 1SD 4		MXN 10MB 4
	0.55	BN 71C 4				M 1LA 4		
		BN 80A 4	BE 80A 4		BXN 80MA 4			MXN 20MA 4
	0.75	BN 80B 4	BE 80B 4	BX 90SR 4	BXN 80MB 4	M 2SA 4	ME 2SB 4	MX 2SB 4
		BN 80C 4						
	1.1	BN 90S 4	BE 90S 4	BX 90S 4	BXN 90S 4	M 2SB 4	ME 3SA 4	MX 3SA 4
		BN 90LA 4	BE 90LA 4	BX 90LA 4	BXN 90L 4	M 3SA 4	ME 3SB 4	MX 3SB 4
	1.85	BN 90LB 4						
	2.2	BN 100LA 4	BE 100LA 4	BX 100LA 4		M 3LA 4	ME 3LA 4	MX 3LA 4
	3	BN 100LB 4	BE 100LB 4	BX 100LB 4		M 3LB 4	ME 3LB 4	MX 3LB 4
	3.7	BN 112M 4	BE 112M 4	BX 112M 4		M 3LC 4	ME 4SA 4	MX 4SA 4
	5.5	BN 132S 4	BE 132S 4	BX 132SB 4		M 4SA 4	ME 4SB 4	MX 4SB 4
	7.5	BN 132MA 4	BE 132MA 4	BX 132MA 4		M 4LA 4	ME 4LA 4	MX 4LA 4
		BN 132MB 4	BE 132MB 4	BX 160MA 4		M 4LB 4	ME 4LB 4	MX 5SA 4
	11	BN 160MR 4						
		BN 160M 4	BE 160M 4	BX 160MB 4		M 4LC 4	ME 5SA 4	MX 5SB 4
	15	BN 160L 4	BE 160L 4	BX 160L 4		M 5SB 4	ME 5LA 4	MX 5LA 4
	18.5	BN 180M 4	BE 180M 4	BX 180M 4		M 5LA 4		
	22	BN 180L 4	BE 180L 4	BX 180L 4				
	30	BN 200L 4		BX 200LAK 4				
	37			BX 225SAK 4				
	45			BX 225SBK 4				
	55			BX 280SAK 4				
	75			BX 280SBK 4				
90			BX 315SAK 4					
110			BX 315SBK 4					
132			BX 315SCK 4					
160			BX 355SAK 4					
200			BX 355SBK 4					
250			BX 355SCK 4					
315			BX 355MBK 4					
355			BX 355MCK 4					

(F82)

6 poligen							
Wirkungsgradklasse	IE1	IE2	IE3	IE1	IE2	IE3	
Pn [kW]	0.06						
	0.09	BN 63A 6			M 05A 6		
	0.12	BN 63B 6			M 05B 6		
	0.18	BN 71A 6			M 1SC 6		
		BN 71B 6					
	0.25	BN 71C 6			M 1SD 6		
		BN 80A 6			M 1LA 6		
	0.37	BN 80A 6			M 1LA 6		
	0.55	BN 80B 6			M 2SA 6		
		BN 80C 6					
	0.75	BN 90S 6			M 2SB 6		
		BN 90L 6			M 3SA 6		
	1.1	BN 90L 6			M 3SA 6		
	1.5	BN 100LA 6			M 3LA 6		
	1.85	BN 100LB 6			M 3LB 6		
	2.2	BN 112M 6			M 3LC 6		
	3	BN 132S 6			M 4SA 6		
	3.7	BN 132MA 6			M 4LA 6		
	5.5	BN 132MB 6			M 4LB 6		
	7.5	BN 160M 6			M 5SA 6		
9.2							
11	BN 160L 6			M 5SB 6			
15	BN 180L 6						
18.5	BN 200LA 6						
22							
30							



M14 MOTORENAUSWAHLTABELLEN BXN-MXN





4 P		1500 min⁻¹ - S1												50 Hz - IE3													
P_n kW		n min ⁻¹	M_n Nm	I_n 400V A	η%		cos φ	I_s I_n	M_s M_n	M_s M_n	KVA code	J_m x 10 ⁻⁴ kgm ²	IM B5 	G.S. Bremse				W.S. Bremse									
					100%	75%								M_b Nm	Z₀ 1/h	SB	IM B5 	Mod	M_b Nm	Z₀ 1/h	J_m x 10 ⁻⁴ kgm ²	FA	Mod	M_b Nm	Z₀ 1/h	J_m x 10 ⁻⁴ kgm ²	IM B5 
0.12	BXN 63MA 4	1407	0.8	0.47	64.8	60.3	0.58	3.4	2.9	1.7	H	1.82	4.6	FD 02	1.8	8900	11000	2.4	6.3	FA 02	1.8	11000	2.4	6.1			
0.18	BXN 63MB 4	1373	1.3	0.61	69.9	68.8	0.61	3.5	3.1	1.8	G	2.92	5.7	FD 02	3.5	7000	9000	3.5	7.4	FA 02	3.5	9000	3.5	7.2			
0.25	BXN 71MA 4	1388	1.7	0.67	73.5	72.8	0.74	4.8	1.6	2.4	H	6.28	6.5	FD 53	5	5700	8100	7.4	9.2	FA 03	5	8100	7.4	8.9			
0.37	BXN 71MB 4	1429	2.5	1.05	77.3	76.0	0.66	6.3	2.6	2.5	L	9.70	8.3	FD 53	5	6400	9900	10.8	11.0	FA 03	5	9900	10.8	10.7			
0.55	BXN 80MA 4	1447	3.6	1.31	80.8	80.9	0.75	6.1	1.9	1.6	J	17.78	10.7	FD 04	10	2500	5200	19.8	14.6	FA 04	10	5200	19.8	14.5			
0.75	BXN 80MB 4	1451	4.9	1.63	82.5	85.1	0.78	7.4	2.4	2.0	K	28.89	14.4	FD 04	15	2000	4100	30.8	18.3	FA 04	15	4100	30.8	18.2			
1.1	BXN 90S 4	1448	7.3	2.38	84.1	85.9	0.78	7.3	2.4	3.4	J	31.76	15.6	FD 05	26	2800	6600	35.8	21.6	FA 05	26	6600	35.8	22.3			
1.5	BXN 90L 4	1441	9.9	3.44	85.3	84.3	0.75	6.7	2.6	2.4	J	34.96	16.6	FD 05	26	1400	3100	39.1	22.6	FA 05	26	3100	39.1	23.3			



Hinweis: Weitere Informationen zu den verfügbaren Energiezertifikaten finden Sie im entsprechenden Abschnitt des Katalogs.

4 P	1500 min⁻¹ - S1	50 Hz - IE3
------------	-----------------------------------	--------------------



		G.S. Bremse											W.S. Bremse											
		FD						FA					FA											
P _n		n	M _n	I _n 400V	η%	cos φ	$\frac{I_s}{I_n}$	$\frac{M_s}{M_n}$	$\frac{M_a}{M_n}$	KVA code	J _m x 10 ⁻⁴ kgm ²	IM B5 	Mod	M _b	Z ₀ 1/h	J _m x 10 ⁻⁴ kgm ²	IM B5 	Mod	M _b	Z ₀ 1/h	J _m x 10 ⁻⁴ kgm ²	IM B5 		
kW		min ⁻¹	Nm	A	100%	50%								Nm	NB	SB				Nm				
0.12	MXN 05MA 4	1407	0.8	0.47	64.8	0.58	3.4	2.9	1.7	H	1.82	4.6	FD 02	1.8	8900	11000	2.4	6.3	FA 02	1.8	11000	2.4	6.1	
0.18	MXN 05MB 4	1373	1.3	0.61	69.9	0.61	3.5	3.1	1.8	G	2.92	5.7	FD 02	3.5	7000	9000	3.5	7.4	FA 02	3.5	9000	3.5	7.2	
0.25	MXN 10MA 4	1388	1.7	0.67	73.5	0.74	4.8	1.6	2.4	H	6.28	6.5	FD 53	5	5700	8100	7.4	9.2	FA 03	5	8100	7.4	8.9	
0.37	MXN 10MB 4	1429	2.5	1.05	77.3	0.66	6.3	2.6	2.5	L	9.70	8.3	FD 53	5	6400	9900	10.8	11.0	FA 03	5	9900	10.8	10.7	
0.55	MXN 20MA 4	1447	3.6	1.31	80.8	0.75	6.1	1.9	1.6	J	17.78	10.7	FD 04	10	2500	5200	19.8	14.6	FA 04	10	5200	19.8	14.5	
0.75	MXN 20MB 4	1451	4.9	1.63	82.5	0.78	7.4	2.4	2.0	K	28.89	14.4	FD 04	15	2000	4100	30.8	18.3	FA 04	15	4100	30.8	18.2	

Hinweis: Weitere Informationen zu den verfügbaren Energiezertifikaten finden Sie im entsprechenden Abschnitt des Katalogs.

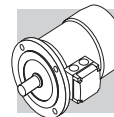

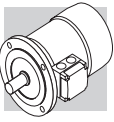

M15 MOTORENABMESSUNGEN BXN-MXN

BXN - IM B5 - CE CUS/UKCA

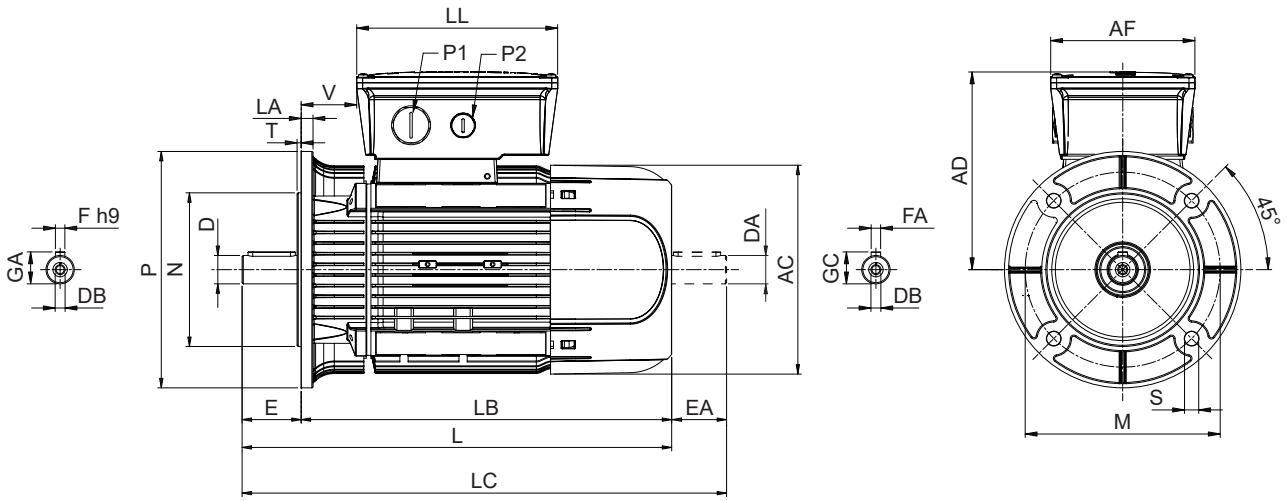

	Welle					Flansch						Motor								
	D DA	E EA	DB	GA GC	F FA	M	N	P	S	T	LA	AC	L	LB	LC	AD	AF	LL	V	
BXN 63	11 9 ⁽¹⁾	23 20 ⁽¹⁾	M4 M3 ⁽¹⁾	12.5 10.2 ⁽¹⁾	4 3 ⁽¹⁾	115	95	140	9.5	3	9	122	281	258	301	136	112	165	37	
BXN 71	14 11 ⁽¹⁾	30 23 ⁽¹⁾	M5 M4 ⁽¹⁾	16 12.5 ⁽¹⁾	5 4 ⁽¹⁾	130	110	160				138	292	262	315	138				34
BXN 80	19 14 ⁽¹⁾	40 30 ⁽¹⁾	M6 M5 ⁽¹⁾	21.5 16 ⁽¹⁾	6 5 ⁽¹⁾	165	130	200	11.5	3.5	10	158	346	306	376	148				40
BXN 90	24 19 ⁽¹⁾	50 40 ⁽¹⁾	M8 M6 ⁽¹⁾	27 21.5 ⁽¹⁾	8 6 ⁽¹⁾							177	365	315	405	170				170

HINWEIS: (1) Diese Maße betreffen das zweite Zweite Wellenverlängerung (PS).

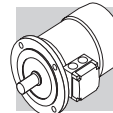

BXN - IM B14 - CE CUS/UKCA

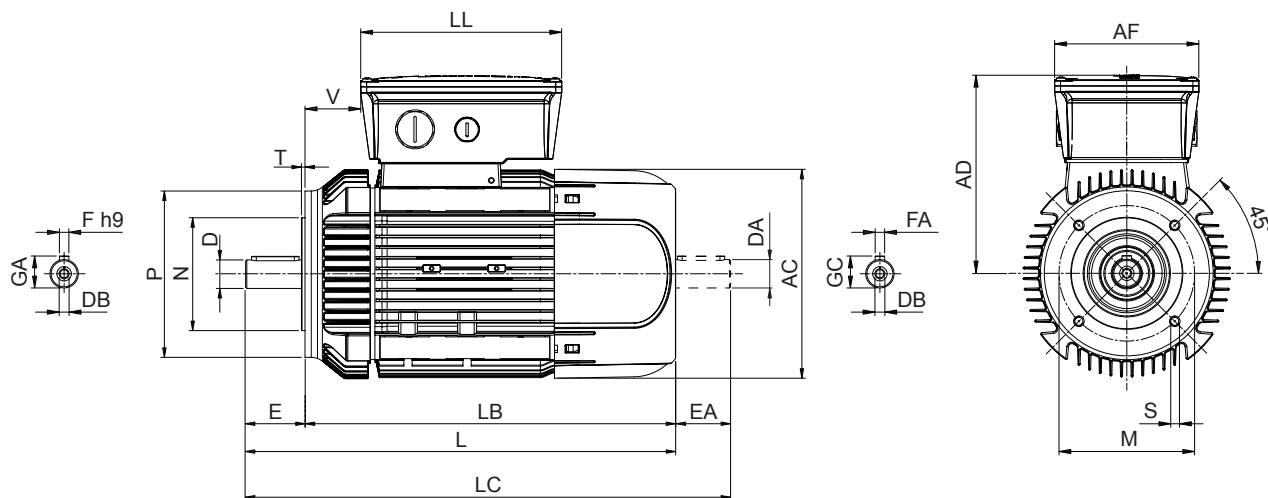

	Welle					Gheuse					Motor							
	D DA	E EA	DB	GA GC	F FA	M	N	P	S	T	AC	L	LB	LC	AD	AF	LL	V
BXN 63	11 9 ⁽¹⁾	23 20 ⁽¹⁾	M4 M3 ⁽¹⁾	12.5 10.2 ⁽¹⁾	4 3 ⁽¹⁾	75	60	90	M5	2.5	122	281	258	301	136	112	165	37
BXN 71	14 11 ⁽¹⁾	30 23 ⁽¹⁾	M5 M4 ⁽¹⁾	16 12.5 ⁽¹⁾	5 4 ⁽¹⁾	85	70	105	M6		138	292	262	315	138			34
BXN 80	19 14 ⁽¹⁾	40 30 ⁽¹⁾	M6 M5 ⁽¹⁾	21.5 16 ⁽¹⁾	6 5 ⁽¹⁾	100	80	120		M8	158	346	306	376	148			40
BXN 90	24 19 ⁽¹⁾	50 40 ⁽¹⁾	M8 M6 ⁽¹⁾	27 21.5 ⁽¹⁾	8 6 ⁽¹⁾	115	95	140	3		177	365	315	405	170			170

HINWEIS: (1) Diese Maße betreffen das zweite Zweite Wellenverlängerung (PS).



BXN - IM B5 - FD/FA - CE - CUS/UKCA

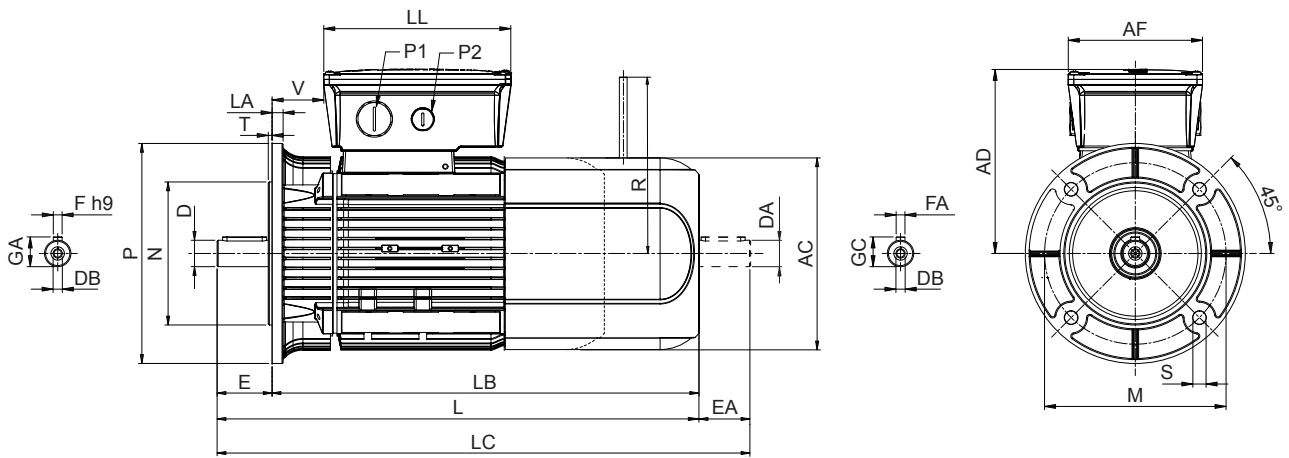

	Welle					Flansch						Motor									
	D	E	DB	GA	F	M	N	P	S	T	LA	AC	L	LB	LC	AD	AF	LL	V	R	
	DA	EA		GC	FA															FD	FA
BXN 63	11 9 ⁽¹⁾	23 20 ⁽¹⁾	M4 M3 ⁽¹⁾	12.5 10.2 ⁽¹⁾	4 3 ⁽¹⁾	115	95	140	9.5	3	9	122	328	305	352	136	112	165	37	96	116
BXN 71	14 11 ⁽¹⁾	30 23 ⁽¹⁾	M5 M4 ⁽¹⁾	16 12.5 ⁽¹⁾	5 4 ⁽¹⁾	130	110	160		9		138	351	321	380	138			34	103	121
BXN 80	19 14 ⁽¹⁾	40 30 ⁽¹⁾	M6 M5 ¹⁾	21.5 16 ⁽¹⁾	6 5 ⁽¹⁾	165	130	200	11.5	3.5	10	158	417	377	448	148			40	129	131
BXN 90	24 19 ⁽¹⁾	50 40 ⁽¹⁾	M8 M6 ⁽¹⁾	27 21.5 ⁽¹⁾	8 6 ⁽¹⁾							177	433	383	451	170			170	43	160

HINWEIS: (1) Diese Maße betreffen das zweite Zweite Wellenverlängerung (PS).

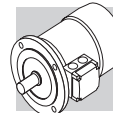

BXN - IM B14 - FD/FA - CE - CUS/UKCA

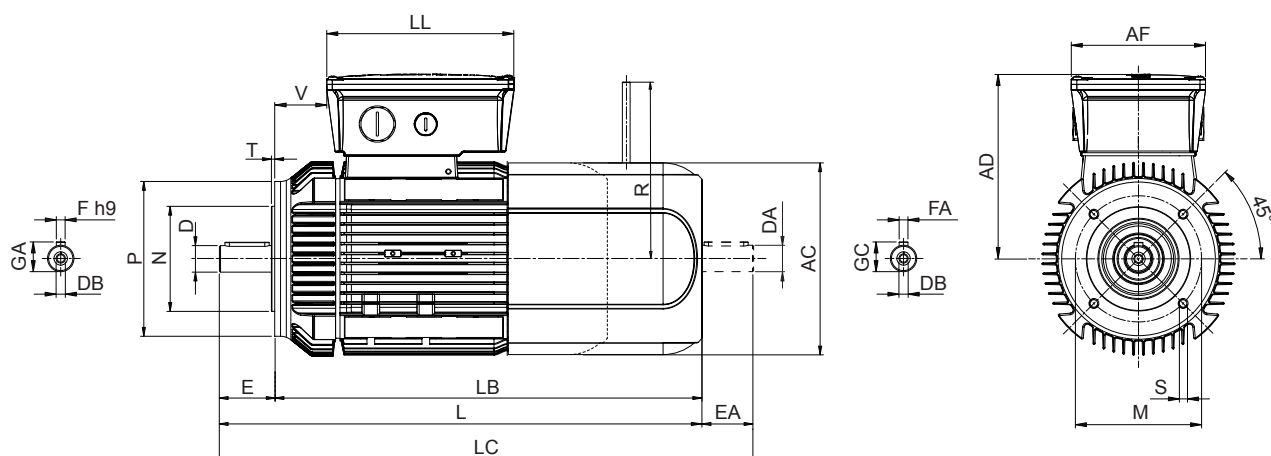

	Welle					Gheuse					Motor									
	D	E	DB	GA	F	M	N	P	S	T	AC	L	LB	LC	AD	AF	LL	V	R	
	DA	EA		GC	FA														FD	FA
BXN 63	11 9 ⁽¹⁾	23 20 ⁽¹⁾	M4 M3 ⁽¹⁾	12.5 10.2 ⁽¹⁾	4 3 ⁽¹⁾	75	60	90	M5	2.5	122	328	305	352	136	112	165	37	96	116
BXN 71	14 11 ⁽¹⁾	30 23 ⁽¹⁾	M5 M4 ⁽¹⁾	16 12.5 ⁽¹⁾	5 4 ⁽¹⁾	85	70	105	M6		138	351	321	380	138			34	103	121
BXN 80	19 14 ⁽¹⁾	40 30 ⁽¹⁾	M6 M5 ⁽¹⁾	21.5 16 ⁽¹⁾	6 5 ⁽¹⁾	100	80	120		3	158	417	377	448	148			40	129	131
BXN 90	24 19 ⁽¹⁾	50 40 ⁽¹⁾	M8 M6 ⁽¹⁾	27 21.5 ⁽¹⁾	8 6 ⁽¹⁾	115	95	140	M8		177	433	383	451	170			170	43	160

HINWEIS: (1) Diese Maße betreffen das zweite Zweite Wellenverlängerung (PS).



MXN

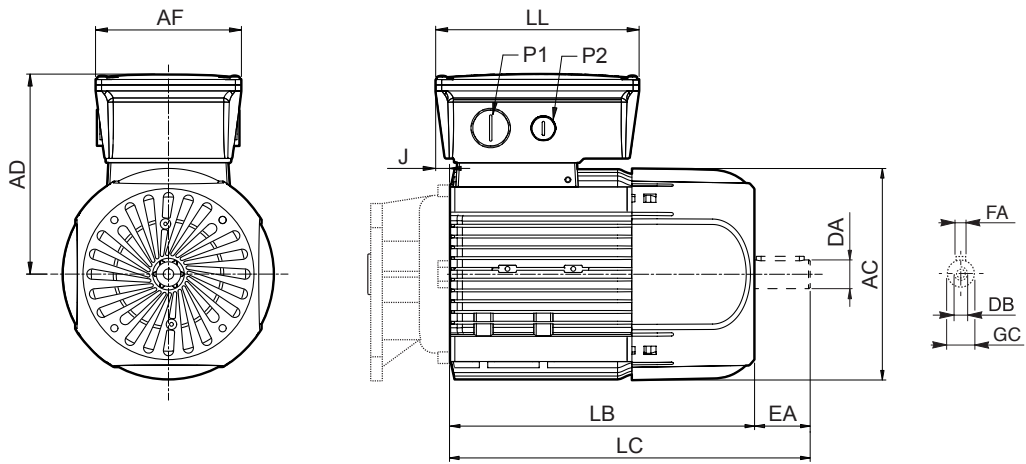

	Zweite Wellenende					Motor						
	DA	EA	DB	FA	GC	AC	LB	LC	AF	LL	J	AD
MXN 05	9	20	M3	3	10.2	123	211.5	231.5	112	165	9.5	136
MXN 10	11	23	M4	4	12.5	138	216	239	112	165	11.5	137
MXN 20	14	30	M5	5	16	158	255.5	285.5	112	165	10.5	146

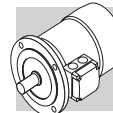

MXN_FD/FA

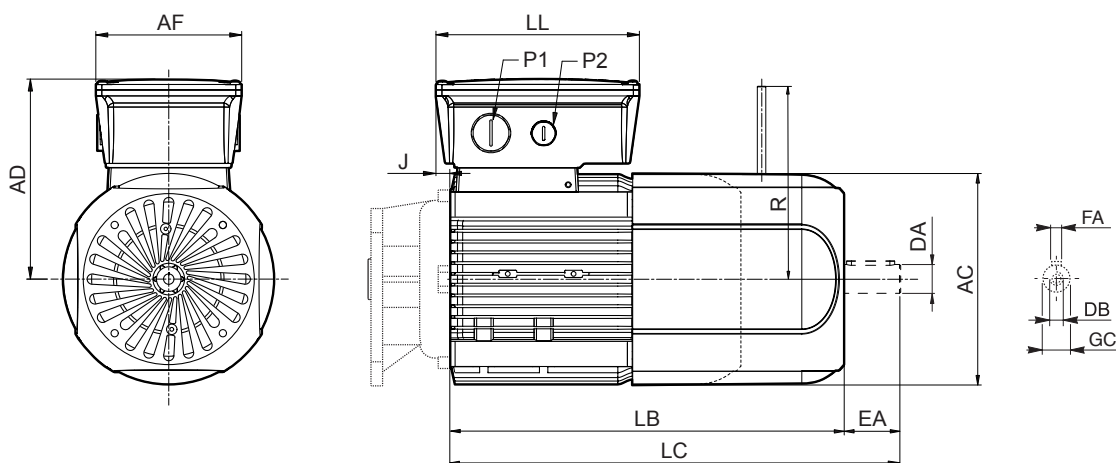

	Zweite Wellenende					Motor								
	DA	EA	DB	FA	GC	AC	LB	LC	AF	LL	J	AD	R	
													FD	FA
MXN 05	9	20	M3	3	10.2	122	211.5	258.5	112	165	9.5	136	96	116
MXN 10	11	23	M4	4	12.5	138	216	275	112	165	11.5	138	103	121
MXN 20	14	30	M5	5	16	158	255.5	326.5	112	165	10.5	148	129	131

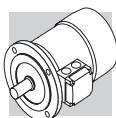

M16 MOTORENAUSWAHLTABELLEN BX-MX

4 P		1500 min ⁻¹ - S1											50 Hz - IE3								
P _n kW	n min ⁻¹	M _n Nm	I _n 400V A	η%			cos φ	I _s I _n	M _s M _n	M _a M _n	KVA code	J _m x 10 ⁻⁴ kgm ²	IM B5 Kg	G.S. Bremse			W.S. Bremse				
				100%	75%	50%								FD			FA				
														Mod	M _b Nm	J _m x 10 ⁻⁴ kgm ²	IM B5 Kg	Mod	M _b Nm	J _m x 10 ⁻⁴ kgm ²	IM B5 Kg
0.75	1425	5.0	1.61	82.5	83.9	83.2	0.81	6.5	2.0	1.8	J	35	16	FD 04	15	37	19.9	FA 04	15	37	19.8
1.1	1425	7.4	2.44	84.1	84.1	82.0	0.77	6.9	3.4	2.2	J	27	16	FD 14	15	29	20.2	FA 14	15	29	20.1
1.5	1420	10.1	3.3	85.3	86.2	84.9	0.78	6.3	3.1	1.9	J	31	17	FD 05	26	35	23	FA 05	26	35	23.7
2.2	1445	14.5	5.1	86.7	86.2	84.0	0.72	7.2	3.6	2.4	K	58	24	FD 15	40	62	31	FA 15	40	62	31
3	1445	19.8	6.7	87.7	87.7	86.0	0.74	7.6	3.9	2.6	K	73	29	FD 15	40	77	36	FA 15	40	77	36
4	1445	26	8.1	88.6	88.9	87.6	0.8	8.1	3.8	2.5	J	130	38	FD 06S	60	139	48	FA 06S	60	139	50
5.5	1460	36	10.6	89.6	89.2	88.8	0.83	8.2	3.6	2.3	J	310	57	FD 56	75	320	70	FA 06	75	320	71
7.5	1460	49	15.0	90.4	90.9	90.2	0.80	8.4	3.8	2.5	K	360	67	FD 06	100	370	80	FA 07	100	370	85
9.2	1465	60	17.8	91.0	92.1	91.7	0.82	7.9	3.6	2.1	J	650	95	FD 08	170	725	125	FA 08	170	725	124
11	1465	72	20.5	91.4	92.9	92.5	0.84	7.8	3.4	1.9	J	780	110	FD 08	170	855	140	FA 08	170	855	139
15	1465	98	28.1	92.1	93.2	92.6	0.82	9.0	4.1	2.3	K	890	121	FD 08	200	965	151	FA 08	200	965	150
18.5	1480	119	32.9	92.6	94.1	93.1	0.85	11.3	2.6	2.3	M	1560	155	FD 09	300	1760	195				
22	1475	142	38.2	93.0	93.6	92.8	0.88	10.2	2.5	2.0	L	1660	163	FD 09	300	1860	203				



Hinweis: Weitere Informationen zu den verfügbaren Energiezertifikaten finden Sie im entsprechenden Abschnitt des Katalogs.

4 P	1500 min⁻¹ - S1	50 Hz - IE3
------------	-----------------------------------	--------------------

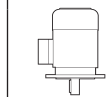

P _n kW	n min ⁻¹	M _n Nm	I _n 400V A	η%		cos φ	I _s I _n	M _s M _n	M _a M _n	KVA code	J _m x 10 ⁻⁴ kgm ²	IM B5 Kg	G.S. Bremse			W.S. Bremse			
				100%	75%								Mod	M _b Nm	J _m x 10 ⁻⁴ kgm ²	IM B5 Kg	Mod	M _b Nm	J _m x 10 ⁻⁴ kgm ²
30	BX 200LA 4	193.2	54.8	93.6	93.9	0.84	7.5	2.7	3.2	N/A	3850	292	FD20	260	3910	317			
37	BX 225SA 4	238.6	68.9	93.9	94.1	0.83	7.2	3.1	3.1	N/A	4270	322	FD25	400	4450	356			
45	BX 225SB 4	290	82.3	94.2	94.4	0.84	8	3.2	3.5	N/A	5250	357	FD25	400	5430	391			
55	BX 250MA 4	354.2	100	94.6	94.7	0.84	7.1	2.9	3.4	N/A	6940	406	FD30	1000	7540	452			
75	BX 280SA 4	483	133	95	95.2	0.86	6.4	2.3	2.8	N/A	13800	645	FD30	1000	14400	691			
90	BX 280SB 4	578	158	95.2	95.5	0.86	7.1	2.5	2.9	N/A	17300	700	FD30	1000	17900	746			
110	BX 315SA 4	705	198	95.4	95.5	0.84	7	2.1	3	N/A	24300	930	FD30	1000	24900	976			
132	BX 315SB 4	847	231	95.6	95.9	0.86	6.7	2.2	2.9	N/A	29000	1000	FD160	1600	30500	1121			
160	BX 315SC 4	1026	282	95.8	96	0.85	6.9	2.2	3	N/A	32000	1065	FD160	1600	33500	1186			
200	BX 315MA 4	1284	351	96	96.4	0.86	6.8	2.4	3	N/A	39000	1220	FD250	2500	41400	1390			
250	BX 355MA 4	1601	435	96	96	0.86	6.4	2.1	2.9	N/A	59000	1610	FD250	2500	61400	1780			
315	BX 355MB 4	2018	550	96	96.1	0.85	7.3	2.4	3.3	N/A	69000	1780	FD400	4000	73300	2000			
355	BX 355MC 4	2273	616	96	96.2	0.86	6.3	2.3	2.8	N/A	72000	1820	FD400	4000	76300	2040			



Hinweis: Weitere Informationen zu den verfügbaren Energiezertifikaten finden Sie im entsprechenden Abschnitt des Katalogs.

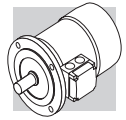

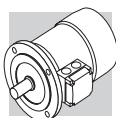



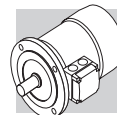

4 P		1500 min ⁻¹ - S1											50 Hz - IE3										
P _n kW	EECA	n min ⁻¹	M _n Nm	I _n 400V A	η%			cos φ	I _s I _n	M _s M _n	M _a M _n	KVA code	J _m x 10 ⁻⁴ kgm ²	IM B5 Kg	G.S. Bremse			W.S. Bremse					
					100%	75%	50%								FD			FA					
															Mod	M _b Nm	J _m x 10 ⁻⁴ kgm ²	IM B5 Kg	Mod	M _b Nm	J _m x 10 ⁻⁴ kgm ²	IM B5 Kg	
30		BX 200LAK 4	193	55.7	94.7	95.1	95	0.82	8.3	3	3.3	N/A	3660	319	FD 8	400	3940	337					
37		BX 225SAK 4	238	65.9	95.1	95.5	95.4	0.85	7.7	2.8	3.1	N/A	5360	398	FD 9	600	5720	426					
45		BX 225SBK 4	290	80.4	95.2	95.6	95.6	0.85	7.9	2.8	3.2	N/A	5360	398	FD 9	600	5720	426					
55		BX 250MAK 4	354	98.9	95.6	95.8	95.5	0.84	7.9	3	3.3	N/A	9330	476	FD 10	800	10080	521					
75		BX 280SAK 4	482	134	95.9	96.2	96.1	0.84	7.3	2.5	2.8	N/A	15000	665	FD 1000	1000	15360	771					
90		BX 280SBK 4	578	161	96.2	96.4	96.1	0.84	7.9	2.9	3	N/A	18500	725	FD 1000	1000	18860	831					
110		BX 315SAK 4	704	194	96.8	97	96.7	0.84	8.3	2.4	3.1	N/A	29000	1000	FD 1000	1000	29360	1106					
132		BX 315SBK 4	846	234	96.9	97.1	96.8	0.84	8.1	2.6	3.2	N/A	32000	1065	FD 1600	1600	32500	1233					
160		BX 315SCK 4	1025	279	96.7	96.9	96.6	0.86	8.2	2.7	3	N/A	39000	1220	FD 1600	1600	39500	1388					
200		BX 355SAK 4	1281	345	96.6	96.7	96.4	0.87	7.3	2.1	2.7	N/A	59000	1610	FD 2500	2500	59500	1778					
250		BX 355MAK 4	1601	435	96	96	95.6	0.86	6.4	2.1	2.9	N/A	69000	1780	FD 2500	2500	69500	1948					
315		BX 355MBK 4	2017	550	96	96.1	95.7	0.85	7.3	2.4	3.3	N/A	72000	1820	FD 2500	2500	72500	1988					
355		BX 355MCK 4	2275	616	96	96.2	95.8	0.86	6.3	2.3	2.8	N/A	84000	2140	FD 2500	2500	84500	2308					

Hinweis: Weitere Informationen zu den verfügbaren Energiezertifikaten finden Sie im entsprechenden Abschnitt des Katalogs.



4 P		1800 min ⁻¹ - S1												60 Hz - Nema Premium								
P _n kW	ENERGY EU US	 <small>REGOLAMENTO EUROPEO DI EFFICIENZA PRIMA CLASSE PER MOTORI PROCEL NBR - 17094-1</small>	n min ⁻¹	M _n Nm	I _n 460V A	η%		cos φ	I _s I _n	M _s M _n	M _a M _n	KVA code	J _m x 10 ⁻⁴ kgm ²	IM B5 	G.S. Bremse				W.S. Bremse			
						100%	75%								FD				FA			
						Mod	M _b Nm								J _m x 10 ⁻⁴ kgm ²	IM B5 	Mod	M _b Nm	J _m x 10 ⁻⁴ kgm ²	IM B5 		
0.75			1755	4.1	1.48	100%	85.5	83.9	0.73	8.0	2.5	L	27	16	FD 14	15	29	20.2	FA 14	15	29	20.1
1.1			1740	6.0	2.15	86.5	86.5	83.0	0.74	8.2	2.8	K	27	16	FD 14	15	29	20.2	FA 14	15	29	20.1
1.5			1735	8.3	2.91	86.5	86.5	84.4	0.75	7.4	2.5	K	31	17	FD 05	26	35	23	FA 05	26	35	23.7
2.2			1760	11.9	4.4	89.5	88.6	86.2	0.71	9.9	3.6	N	73	29	FD 15	40	77	36	FA 15	40	77	36
3			1750	16.4	5.9	89.5	88.9	86.7	0.71	9.1	3.3	M	73	29	FD 15	40	77	36	FA 15	40	77	36
3.7			1760	20	6.7	89.5	89.5	89.1	0.77	10.4	3.4	M	130	38	FD 06S	60	139	48	FA 06S	60	139	50
5.5			1770	30	9.9	91.7	92.0	90.2	0.76	10.7	4.6	N	410	77	FD 56	75	420	90	FA 06	75	420	91
7.5			1770	41	13.4	91.7	91.3	89.7	0.76	11.0	4.4	N	410	77	FD 06	100	420	90	FA 07	100	420	95
9.2			1770	50	15.6	92.4	92.4	91.6	0.8	9.1	2.6	L	650	95	FD 08	170	725	125	FA 08	170	725	124
11			1770	59	18.2	92.4	92.9	92.0	0.82	9.3	2.4	L	780	110	FD 08	170	855	140	FA 08	170	855	139
15			1770	81	24.5	93.0	93.0	92.5	0.81	10.9	2.8	M	890	121	FD 08	200	965	151	FA 08	200	965	150
18.5			1780	99	28.6	93.6	93.6	93.2	0.85	13.0	2.7	N	1560	155	FD 09	300	1760	195				
22			1775	118	33.1	93.6	94.2	93.1	0.87	11.5	2.4	M	1660	163	FD 09	300	1860	203				

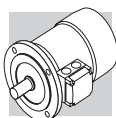

Hinweis: Weitere Informationen zu den verfügbaren Energiezertifikaten finden Sie im entsprechenden Abschnitt des Katalogs.





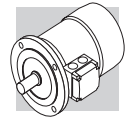

4 P		1800 min ⁻¹ - S1												60 Hz - Nema Premium							
P _n kW	n min ⁻¹	M _n Nm	I _n 460V A	η%		cos φ	I _s I _n	M _s M _n	M _a M _n	KVA code	J _m x 10 ⁻⁴ kgm ²	IM B5 Kg	G.S. Bremse			W.S. Bremse					
				100%	75%								50%	FD			FA				
												IM B5 Kg	Mod	M _b Nm	J _m x 10 ⁻⁴ kgm ²	IM B5 Kg	Mod	M _b Nm	J _m x 10 ⁻⁴ kgm ²	IM B5 Kg	
30	BX 200LAK 4	1786	160	47.9	94.7	94.8	94.1	3.3	3.7	N/A	3660	319	FD 8	400	3940	337					
37	BX 225SAK 4	1784	198	57.3	95.3	95.5	94.9	2.9	3.4	N/A	5360	398	FD 9	600	5720	426					
45	BX 225SBK 4	1785	240	70.5	95.3	95.4	94.8	3	3.6	N/A	5360	398	FD 9	600	5720	426					
55	BX 250MAK 4	1787	293	85.8	95.7	95.8	95.2	3.3	3.7	N/A	9330	476	FD 10	800	10080	521					
75	BX 280SAK 4	1788	401	117	95.9	95.7	94.7	2.7	3.1	N/A	15000	665	FD 1000	1000	15360	771					
90	BX 280SBK 4	1788	481	140	96.1	95.9	95	3.1	3.3	N/A	18500	725	FD 1000	1000	18860	831					
110	BX 315SAK 4	1792	586	172	96.1	96	95.3	2.6	3.4	N/A	29000	1000	FD 1000	1000	29360	1106					
132	BX 315SBK 4	1791	704	206	96.4	96.3	95.6	2.8	3.6	N/A	32000	1065	FD 1600	1600	32500	1233					
160	BX 315SCK 4	1791	853	241	96.4	96.4	95.9	2.9	3.3	N/A	39000	1220	FD 1600	1600	39500	1388					
200	BX 355SAK 4	1792	1065	301	96.4	96.2	95.4	2.2	3	N/A	59000	1610	FD 2500	2500	59500	1778					
250	BX 355MAK 4	1792	1332	381	96.7	96.6	96	2.7	3.2	N/A	69000	1780	FD 2500	2500	69500	1948					
315	BX 355MBK 4	1791	1679	479	96.7	96.6	96.1	3.1	3.2	N/A	72000	1820	FD 2500	2500	72500	1988					
355	BX 355MCK 4	1792	1893	541	96.7	96.5	96.9	2.4	3.1	N/A	84000	2140	FD 2500	2500	84500	2308					

Hinweis: Weitere Informationen zu den verfügbaren Energiezertifikaten finden Sie im entsprechenden Abschnitt des Katalogs.

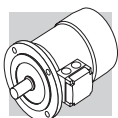

4 P		1500 min ⁻¹ - S1										50 Hz - IE3									
		G.S. Bremse										W.S. Bremse									
P _n kW		n min ⁻¹	M _n Nm	I _n 400V A	η%		cos φ	$\frac{I_s}{I_n}$	$\frac{M_s}{M_n}$	$\frac{M_a}{M_n}$	KVA code	J _m x 10 ⁻⁴ kgm ²	IM B5 	FD			FA				
					100%	75%								50%	Mod	M _b Nm	J _m x 10 ⁻⁴ kgm ²	IM B5 	Mod	M _b Nm	J _m x 10 ⁻⁴ kgm ²
0.75	MX 2SB	4	5.0	1.61	82.5	83.9	0.81	6.5	2.0	1.8	J	35	16	FD 04	15	37	19.9	FA 04	15	37	19.8
1.1	MX 3SA	4	7.3	2.46	84.1	85.5	0.75	6.7	3.0	2.0	J	35	17	FD 15	15	26	24	FA 15	15	26	24
1.5	MX 3SB	4	9.9	3.3	85.3	86.8	0.75	6.7	3.1	2.0	J	43	20	FD 15	26	47	27	FA 15	26	47	27
2.2	MX 3LA	4	14.5	5.1	86.7	86.2	0.72	7.2	3.6	2.4	K	58	24	FD 15	40	62	31	FA 15	40	62	31
3	MX 3LB	4	19.8	6.7	87.7	87.7	0.74	7.6	3.9	2.6	K	73	29	FD 15	40	77	36	FA 15	40	77	36
4	MX 4SA	4	26	7.8	88.6	89.9	0.82	8.1	3.7	2.5	J	225	45	FD 56	75	235	58	FA 06	75	235	59
5.5	MX 4SB	4	36	10.6	89.6	89.9	0.83	8.2	3.6	2.3	J	310	57	FD 56	75	320	70	FA 06	75	320	71
7.5	MX 4LA	4	49	15.0	90.4	90.9	0.80	8.4	3.8	2.5	K	360	67	FD 06	100	370	80	FA 07	100	370	85
9.2	MX 5SA	4	60	17.8	91.0	92.1	0.82	7.9	3.6	2.1	J	650	95	FD 08	170	725	125	FA 08	170	725	124
11	MX 5SB	4	72	20.5	91.4	92.9	0.84	7.8	3.4	1.9	J	780	110	FD 08	170	855	140	FA 08	170	855	139
15	MX 5LA	4	98	28.1	92.1	93.2	0.82	9.0	4.1	2.3	K	890	121	FD 08	200	965	151	FA 08	200	965	150



4 P		1800 min ⁻¹ - S1													60 Hz - IE3						
P _n kW		n min ⁻¹	M _n Nm	I _n 460V A	η%			cos φ	I _s I _n	M _s M _n	M _a M _n	KVA code	J _m x 10 ⁻⁴ kgm ²	IM B5 	G.S. Bremse			W.S. Bremse			
					100%	75%	50%								Mod	M _b Nm	J _m x 10 ⁻⁴ kgm ²	IM B5 	Mod	M _b Nm	J _m x 10 ⁻⁴ kgm ²
0.75	MX 2SB 4	1755	4.1	1.48	85.5	86.4	83.9	0.73	3.7	2.5	L	27	16	FD 14	15	29	20.2	FA 14	15	29	20.1
1.1	MX 3SA 4	1755	6.0	2.19	86.5	86.0	83.0	0.73	3.3	2.5	L	35	17	FD 15	15	26	24	FA 15	15	26	24
1.5	MX 3SB 4	1755	8.2	2.96	86.5	87.2	85.0	0.72	3.7	2.9	L	43	20	FD 15	26	47	27	FA 15	26	47	27
2.2	MX 3LA 4	1760	11.9	4.4	89.5	88.6	86.2	0.71	4.8	3.6	N	73	29	FD 15	40	77	36	FA 15	40	77	36
3	MX 3LB 4	1750	16.4	5.9	89.5	88.9	86.7	0.71	4.4	3.3	M	73	29	FD 15	40	77	36	FA 15	40	77	36
3.7	MX 4SA 4	1770	20.0	6.6	89.5	89.8	87.7	0.78	4.7	3.4	M	225	45	FD 56	75	235	58	FA 06	75	235	59
5.5	MX 4SB 4	1770	30	9.9	91.7	92.0	90.2	0.76	5.1	4.6	N	410	77	FD 56	75	420	90	FA 06	75	420	91
7.5	MX 4LA 4	1770	41	13.4	91.7	91.3	89.7	0.76	4.9	4.4	N	410	77	FD 06	100	420	90	FA 07	100	420	95
9.2	MX 5SA 4	1770	50	15.6	92.4	92.5	91.6	0.8	4.1	2.6	L	650	95	FD 08	170	725	125	FA 08	170	725	124
11	MX 5SB 4	1770	59	18.2	92.4	92.9	92.0	0.82	4.0	2.4	L	780	110	FD 08	170	855	140	FA 08	170	855	139
15	MX 5LA 4	1770	81	24.5	93.0	93.5	92.5	0.81	4.8	2.8	M	890	121	FD 08	200	965	151	FA 08	200	965	150

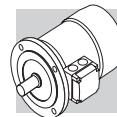

M17 MOTORENABMESSUNGEN BX-MX

BX - IM B5 - CE/CCC

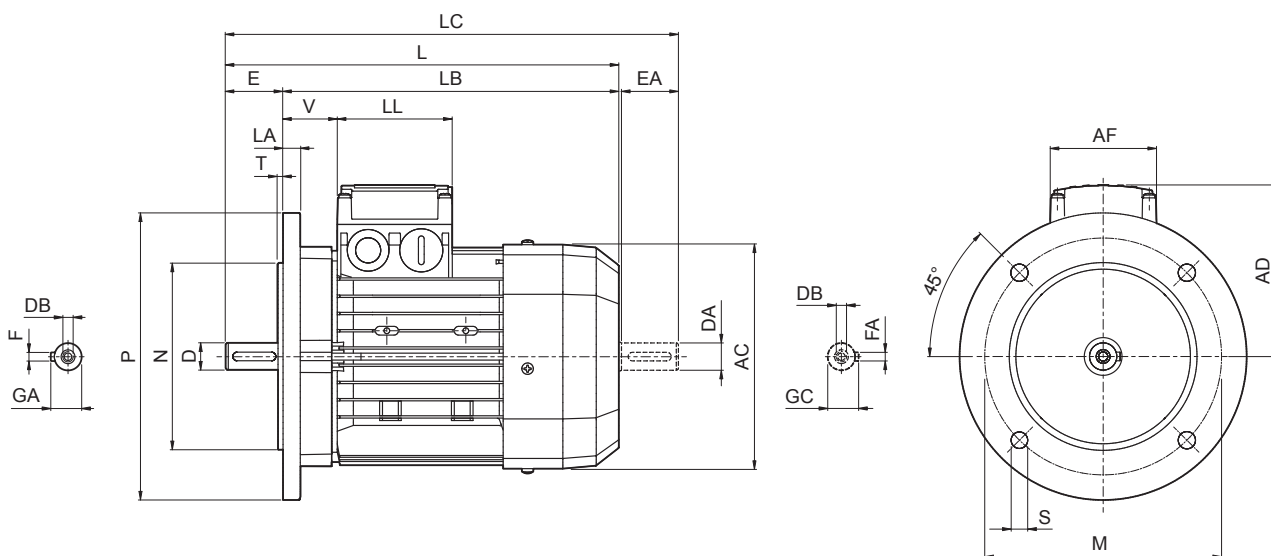

	Welle					Flansch						Motor											
	D DA	E EA	DB	GA GC	F FA	M	N	P	S	T	LA	AC	L	LB	LC	AD	AF	LL	V				
BX 80 B	19 14 ⁽¹⁾	40 30 ⁽¹⁾	M6 M5 ⁽¹⁾	21.5 16 ⁽¹⁾	6 5 ⁽¹⁾	165	130	200	11.5	3.5	11.5	156	320	280	351	119	74	80	38				
BX 90 S	24 19 ⁽¹⁾	50 40 ⁽¹⁾	M8 M6 ⁽¹⁾	27 21.5 ⁽¹⁾	8 6 ⁽¹⁾							176	326	276	368	133	98	98	44				
BX 90 LA																							
BX 100 LA	28 24 ⁽¹⁾	60 50 ⁽¹⁾	M10 M8 ⁽¹⁾	31 27 ⁽¹⁾	8 8 ⁽¹⁾	215	180	250	14	4	14	195	410	350	462	142	118	118	50				
BX 100 LB												20	258	493	413	556			193	58			
BX 112 M																					15	219	430
BX 132 SB	38 28 ⁽¹⁾	80 60 ⁽¹⁾	M12 M10 ⁽¹⁾	41 31 ⁽¹⁾	10 8 ⁽¹⁾	265	230	300	14	4	20	258	493	413	556	193	118	118	58				
BX 132 MA												528	448	591	187	187	51						
BX 160 MA	42 38 ⁽¹⁾	110 80 ⁽¹⁾	M16 M12 ⁽¹⁾	45 41 ⁽¹⁾	12 10 ⁽¹⁾	300	250	350	18.5	15	310	596	486	680	245	187	187	51					
BX 160 MB												640	530	724	51								
BX 160 L																							
BX 180 M	48 42 ⁽¹⁾	110 110 ⁽¹⁾	M16 M16 ⁽¹⁾	51.5 45 ⁽¹⁾	14 12 ⁽¹⁾	350	300	400	5	18	348	708	598	823	261	311	48						
BX 180 L																							
BX 200LA	55 45 ⁽¹⁾	140 110 ⁽¹⁾	M20 M20 ⁽¹⁾	59 48.5 ⁽¹⁾	16 14 ⁽¹⁾	500	450	550	19	20	423	821	711	934	328	300	311	48					
BX 225SA	60 55 ⁽¹⁾			64 59 ⁽¹⁾	18 16 ⁽¹⁾							400	350	450	24				514	884	744	1010	376
BX 225SB																							
BX 250MA	65 55 ⁽¹⁾	170 140 ⁽¹⁾	M20 M20 ⁽¹⁾	69 59 ⁽¹⁾	79.5 69 ⁽¹⁾	20 18 ⁽¹⁾	23	567	1088	948	1238	482	434	306	43								
BX 280SA	75 65 ⁽¹⁾			140 140 ⁽¹⁾												79.5 69 ⁽¹⁾	20 18 ⁽¹⁾						
BX 280SB																							
BX 315SA	80 75 ⁽¹⁾	170 140 ⁽¹⁾	M20 M20 ⁽¹⁾	85 79.5 ⁽¹⁾	22 20 ⁽¹⁾	600	550	660	23	6	25	645	1204	1034	1352	537	473	347	42				
BX 315SB													1315	1145	1463								
BX 315SC																							
BX 315MA	90 75 ⁽¹⁾	210 170 ⁽¹⁾	M24 M24 ⁽¹⁾	95 79.5 ⁽¹⁾	25 20 ⁽¹⁾	740	680	800	740	1479	1269	1659	603	694	413	50							
BX 355MA																							
BX 355MB																							
BX 355MC	100 75 ⁽¹⁾	210 170 ⁽¹⁾	M24 M24 ⁽¹⁾	106 79.5 ⁽¹⁾	28 20 ⁽¹⁾	740	680	800	740	1479	1269	1659	603	694	413	50							

HINWEIS: (1) Diese Maße betreffen das zweite Wellenverlängerung (PS).



BX - IM B14 - CE/CCC

BX-MX

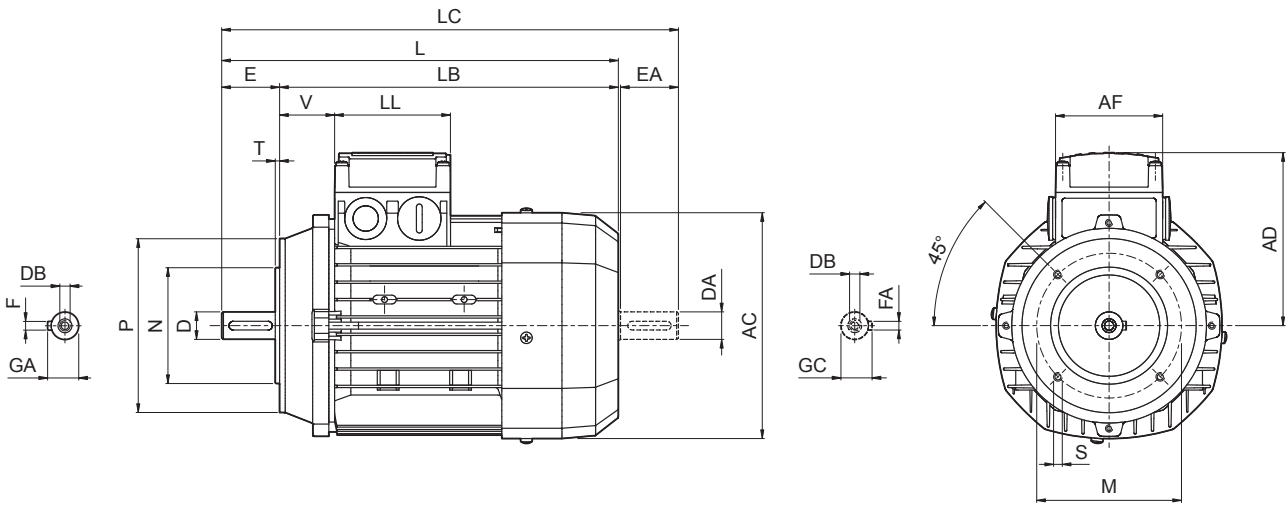

	Welle					Gehäuse					Motor							
	D DA	E EA	DB	GA GC	F FA	M	N	P	S	T	AC	L	LB	LC	AD	AF	LL	V
BX 80 B	19 14 ⁽¹⁾	40 30 ⁽¹⁾	M6 M5 ⁽¹⁾	21.5 16 ⁽¹⁾	6 5 ⁽¹⁾	100	80	120	M6		156	320	280	351	119	74	80	38
BX 90 S	24 19 ⁽¹⁾	50 40 ⁽¹⁾	M8 M6 ⁽¹⁾	27 21.5 ⁽¹⁾	8 6 ⁽¹⁾	115	95	140	M8	3	176	326	276	368	133	98	98	44
BX 90 LA																		
BX 100 LA	28 24 ⁽¹⁾	60 50 ⁽¹⁾	M10 M8 ⁽¹⁾	31 27 ⁽¹⁾	8 8 ⁽¹⁾	130	110	160	M8	3.5	195	410	350	462	142	98	98	50
BX 100 LB																		
BX 112 M																		
BX 132 SB	38 28 ⁽¹⁾	80 60 ⁽¹⁾	M12 M10 ⁽¹⁾	41 31 ⁽¹⁾	10 8 ⁽¹⁾	165	130	200	M10	4	258	493	413	556	193	118	118	58
BX 132 MA												528	448	591				

HINWEIS: (1) Diese Maße betreffen das zweite Zweite Wellenverlängerung (PS).

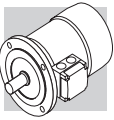

BX - IM B14 - FD/FA - CE/CCC

BX-MX

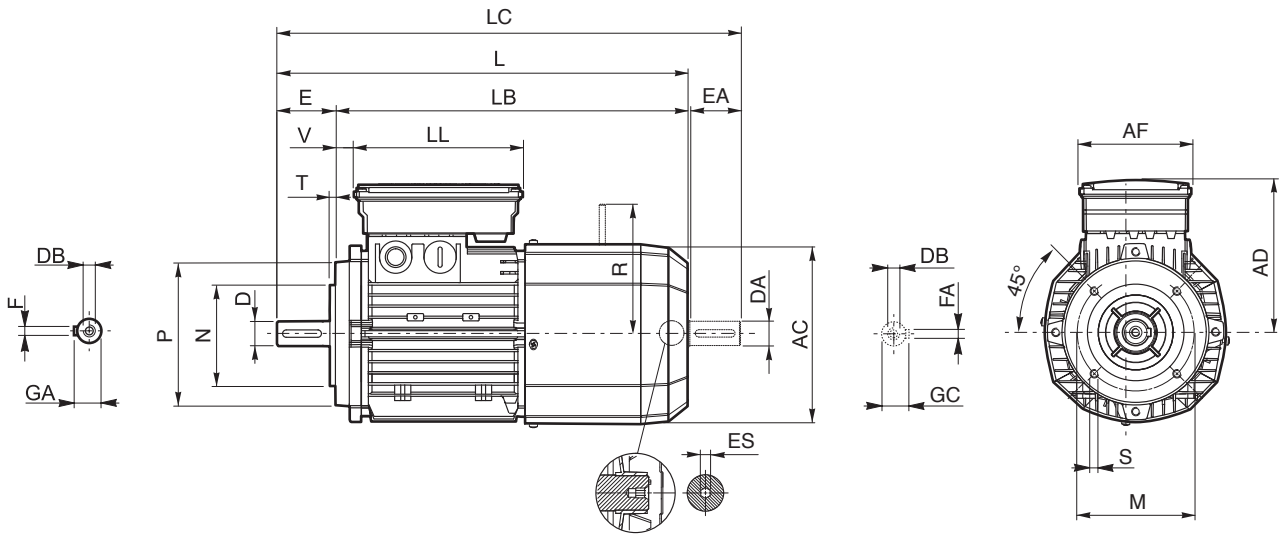

	Welle					Gehäuse					Motor											
	D	E	DB	GA	F	M	N	P	S	T	AC	L	LB	LC	AD	AF	LL	V	R		ES ⁽²⁾	
	DA	EA		GC	FA														FD	FA		
BX 80 B	19 14 ⁽¹⁾	40 30 ⁽¹⁾	M6 M5 ⁽¹⁾	21.5 16 ⁽¹⁾	6 5 ⁽¹⁾	100	80	120	M6		156	392	352	423	143	98	133	25		129	134	5
BX 90 S	24 19 ⁽¹⁾	50 40 ⁽¹⁾	M8 M6 ⁽¹⁾	27 21.5 ⁽¹⁾	8 6 ⁽¹⁾	115	95	140		3	176	410	360	452	146			32				
BX 90 LA																						
BX 100 LA									M8		195	502	442	554	155	110	165		37	160	160	
BX 100 LB	28 24 ⁽¹⁾	60 50 ⁽¹⁾	M10 M8 ⁽¹⁾	31 27 ⁽¹⁾	8 8 ⁽¹⁾	130	110	160		3.5												6
BX 112 M											219	527	467	579	170			39	199	198		
BX 132 SB	38 28 ⁽¹⁾	80 60 ⁽¹⁾	M12 M10 ⁽¹⁾	41 31 ⁽¹⁾	10 8 ⁽¹⁾	165	130	200	M10	4	258	603	523	667		210	140	188	46	204	200	
BX 132 MA												627	547	690							226	

HINWEIS: (1) Diese Maße betreffen das zweite Zweite Wellenverlängerung (PS). (2) Der Sechskant ES ist bei der Option PS nicht vorhanden.

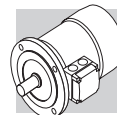

BX - IM B5 - CUS/NBR/EECA

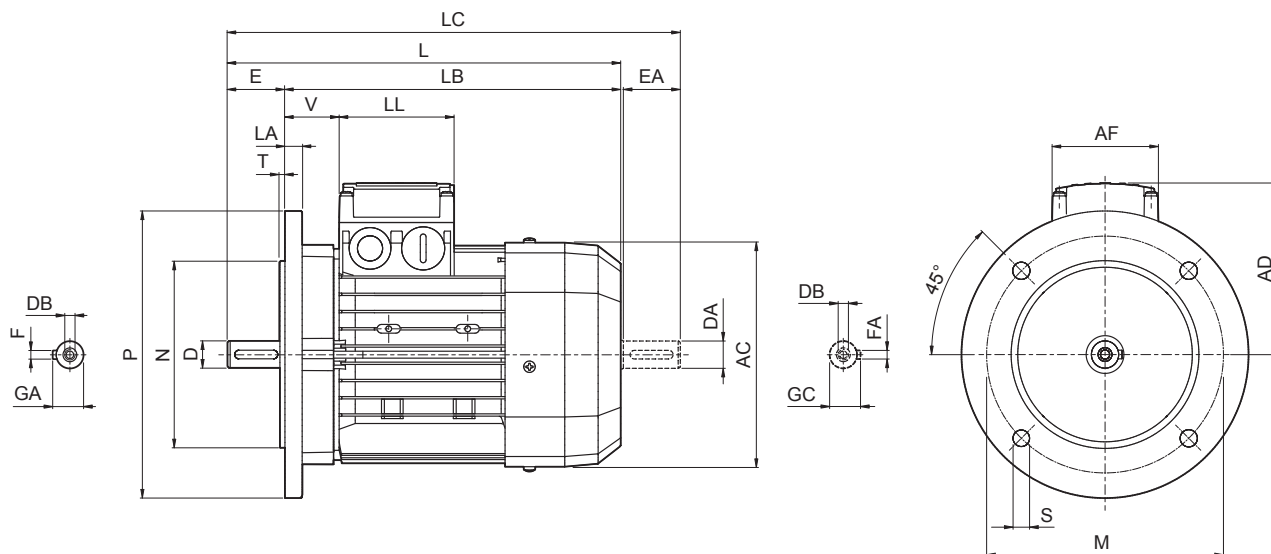

	Welle					Flansch					Motor								
	D DA	E EA	DB	GA GC	F FA	M	N	P	S	T	LA	AC	L	LB	LC	AD	AF	LL	V
BX 90 SR	19 19 ⁽¹⁾	40 40 ⁽¹⁾	M6 M6 ⁽¹⁾	21.5 21.5 ⁽¹⁾	6 6 ⁽¹⁾	165	130	200	11.5	3.5	11.5	176	316	276	358	133	98	98	44
BX 90 S	24 19 ⁽¹⁾	50 40 ⁽¹⁾	M8 M6 ⁽¹⁾	27 21.5 ⁽¹⁾	8 6 ⁽¹⁾								326		368				
BX 90 LA																			
BX 100 LA	28 24 ⁽¹⁾	60 50 ⁽¹⁾	M10 M8 ⁽¹⁾	31 27 ⁽¹⁾	8 8 ⁽¹⁾	215	180	250	14	4	14	195	410	350	462	142	187	187	50
BX 100 LB													430	370	482	157			52
BX 112 M													15	219	430	370			482
BX 132 SB	38 28 ⁽¹⁾	80 60 ⁽¹⁾	M12 M10 ⁽¹⁾	41 31 ⁽¹⁾	10 8 ⁽¹⁾	265	230	300	20	258	552	472	615	193	118	118	58		
BX 132 MA																			
BX 160 MA	42 38 ⁽¹⁾	110 80 ⁽¹⁾	M16 M12 ⁽¹⁾	45 41 ⁽¹⁾	12 10 ⁽¹⁾	300	250	350	18.5	5	15	310	596	486	680	245	187	187	51
BX 160 MB													640	530	724				52
BX 160 L																			
BX 180 M	48 42 ⁽¹⁾	110 110 ⁽¹⁾	M16 M16 ⁽¹⁾	51.5 45 ⁽¹⁾	14 12 ⁽¹⁾	350	300	400	19	5	20	423	821	711	934	328	300	311	55
BX 180 L																			
BX 200LAK	55 45 ⁽¹⁾	110 110 ⁽¹⁾	M20 M20 ⁽¹⁾	59 48.5 ⁽¹⁾	16 14 ⁽¹⁾	350	300	400	19	5	20	423	821	711	934	328	300	311	55
BX 225SAK	60 55 ⁽¹⁾	140 110 ⁽¹⁾	M20 M20 ⁽¹⁾	64 59 ⁽¹⁾	18 16 ⁽¹⁾	400	350	450	19	5	20	465	879	739	1001	348	300	311	48
BX 225SBK																			
BX 250MAK	65 55 ⁽¹⁾	140 110 ⁽¹⁾	M20 M20 ⁽¹⁾	69 59 ⁽¹⁾	18 16 ⁽¹⁾	500	450	550	19	5	24	514	884	744	1010	376	300	311	
BX 280SAK	75 65 ⁽¹⁾	140 140 ⁽¹⁾	M20 M20 ⁽¹⁾	79.5 69 ⁽¹⁾	20 18 ⁽¹⁾	500	450	550	18	5	23	567	1088	948	1238	482	434	306	43
BX 280SBK																			
BX 315SAK	80 75 ⁽¹⁾	170 140 ⁽¹⁾	M20 M20 ⁽¹⁾	85 79.5 ⁽¹⁾	22 20 ⁽¹⁾	600	550	660	23	6	25	645	1204	1034	1352	537	473	347	42
BX 315SBK													1315	1145	1453				
BX 315SCK																			
BX 355SAK	100 75 ⁽¹⁾	210 170 ⁽¹⁾	M24 M20 ⁽¹⁾	106 79.5 ⁽¹⁾	28 20 ⁽¹⁾	740	680	800	23	6	25	740	1479	1269	1659	603	694	413	50
BX 355MAK													1584	1374	1764				
BX 355MBK																			
BX 355MCK																			

HINWEIS: (1) Diese Maße betreffen das zweite Wellenverlängerung (PS).

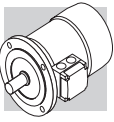

BX - IM B14 - CUS/NBR

BX-MX

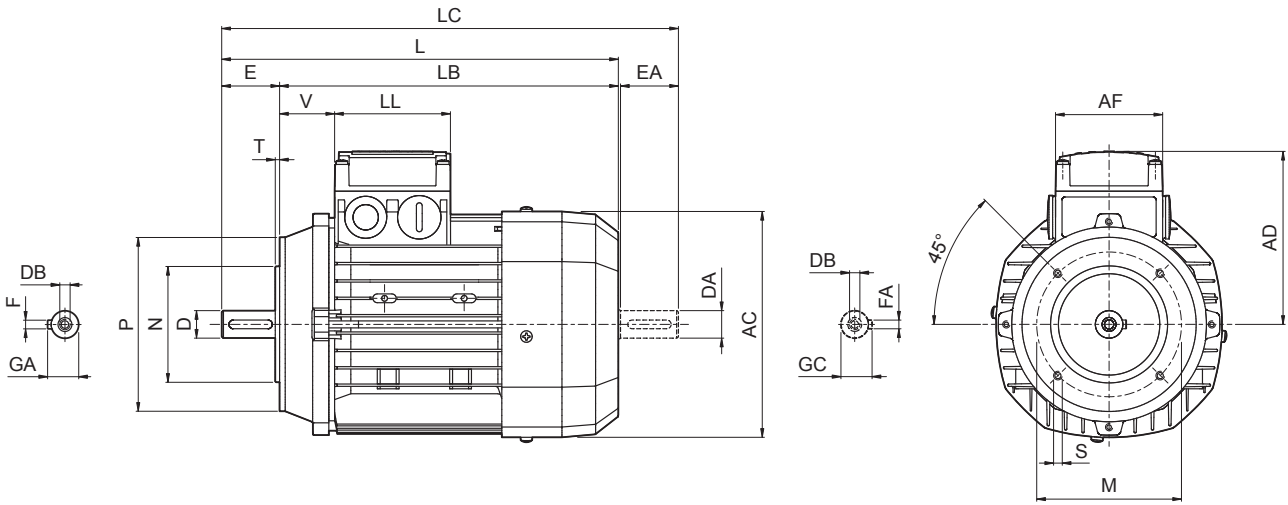

	Welle					Gehäuse					Motor													
	D DA	E EA	DB	GA GC	F FA	M	N	P	S	T	AC	L	LB	LC	AD	AF	LL	V						
BX 90 SR	19 19 ⁽¹⁾	40 40 ⁽¹⁾	M6 M6 ⁽¹⁾	21.5 21.5 ⁽¹⁾	6 6 ⁽¹⁾	100	80	120	M6	3	176	316	276	358	133	98	98	44						
BX 90 S	24 19 ⁽¹⁾	50 40 ⁽¹⁾	M8 M6 ⁽¹⁾	27 21.5 ⁽¹⁾	8 6 ⁽¹⁾	115	95	140	M8			3.5		195					326	368	142			
BX 90 LA											219		430						370			482	157	50
BX 100 LA	28 24 ⁽¹⁾	60 50 ⁽¹⁾	M10 M8 ⁽¹⁾	31 27 ⁽¹⁾	8 8 ⁽¹⁾	130	110	160	M10	4	258	552	472	615	193	118	118	58						
BX 100 LB																			219	430	370	482	157	52
BX 112 M																			219	430	370	482	157	52
BX 132 SB	38 28 ⁽¹⁾	80 60 ⁽¹⁾	M12 M10 ⁽¹⁾	41 31 ⁽¹⁾	10 8 ⁽¹⁾	165	130	200	M10	4	258	552	472	615	193	118	118	58						
BX 132 MA																			219	430	370	482	157	52

HINWEIS: (1) Diese Maße betreffen das zweite Zweite Wellenverlängerung (PS).



BX-MX

BX - IM B5 - FD/FA - CUS/NBR/EECA

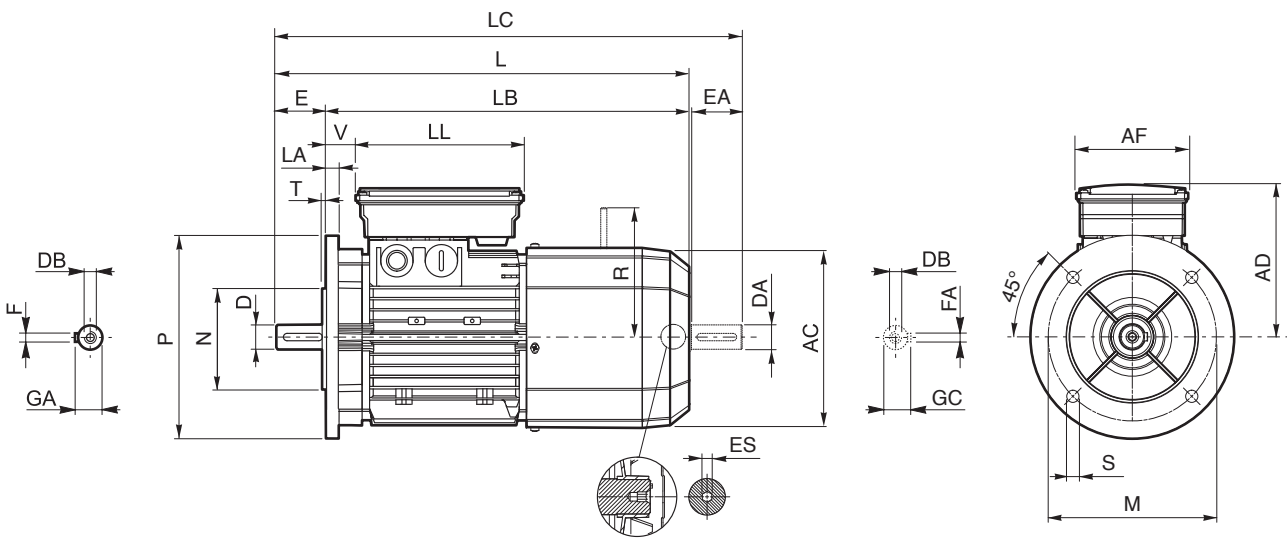

	Welle					Flansch					Motor													
	D	E	DB	GA	F	M	N	P	S	T	LA	AC	L	LB	LC	AD	AF	LL	V	R		ES		
	DA	EA	M	GC	FA															FD	FA	(2)		
BX 90 SR	19 19 ⁽¹⁾	40 40 ⁽¹⁾	M6 M6 ⁽¹⁾	21.5 21.5 ⁽¹⁾	6 6 ⁽¹⁾								400		442									
BX 90 S	24 19 ⁽¹⁾	50 40 ⁽¹⁾	M8 M6 ⁽¹⁾	27 21.5 ⁽¹⁾	8 6 ⁽¹⁾	165	130	200	11.5	3.5	11.5	176	410	360	452	146			32	129	134			
BX 90 LA																	110	165						
BX 100 LA																								
BX 100 LB	28 24 ⁽¹⁾	60 50 ⁽¹⁾	M10 M8 ⁽¹⁾	31 27 ⁽¹⁾	8 8 ⁽¹⁾	215	180	250			14	195	502	442	554	155			37	160	160	6		
BX 112 M									14	4									39	199	198			
BX 132 SB	38 28 ⁽¹⁾	80 60 ⁽¹⁾	M12 M10 ⁽¹⁾	41 31 ⁽¹⁾	10 8 ⁽¹⁾	265	230	300			15	219	527	467	579	170								
BX 132 MA											16	258	661	581	724	210	140	188	46	204	200		226	
BX 160 MA														736	626	820								
BX 160 MB	42 38 ⁽¹⁾	110 80 ⁽¹⁾	M16 M12 ⁽¹⁾	45 41 ⁽¹⁾	12 10 ⁽¹⁾						15	310	780	670	864	245			51	266	247			
BX 160 L						300	250	350	18.5	5							187	187						
BX 180 M	48 42 ⁽¹⁾		M16	51.5	14						18	348	866	756	981	261			52	305				
BX 180 L		110 110 ⁽¹⁾	M16 ⁽¹⁾	45 ⁽¹⁾	12 ⁽¹⁾																			
BX 200LAK	55 45 ⁽¹⁾		M20 M16 ⁽¹⁾	59 48.5 ⁽¹⁾	16 14 ⁽¹⁾	350	300	400					417	967	857	1082	328							
BX 225SAK	60 55 ⁽¹⁾	140 110 ⁽¹⁾		64 59 ⁽¹⁾	18 16 ⁽¹⁾	400	350	450	19				20	460	1065	925	1180	348	300	311	48	308		
BX 225SBK																								
BX 250MAK	65 55 ⁽¹⁾			69 59 ⁽¹⁾									24	510	1070	930	1240	376					313	
BX 280SAK	75 65 ⁽¹⁾	140 140 ⁽¹⁾	M20 M20 ⁽¹⁾	79.5 69 ⁽¹⁾	20 18 ⁽¹⁾	500	450	550	18				23	564	1284	1144	1379	482	434	306	43			
BX 280SBK																								
BX 315SAK														1493	1323	1643								
BX 315SBK	80 75 ⁽¹⁾	170 140 ⁽¹⁾		85 79.5 ⁽¹⁾	22 20 ⁽¹⁾	600	550	660					639	1530	1360	1680	537	473	347	42			500	
BX 315SCK														1604	1434	1791								
BX 355SAK									23	6	25													
BX 355MAK	100 90 ⁽¹⁾	210 170 ⁽¹⁾	M24 M24 ⁽¹⁾	106 95 ⁽¹⁾	28 25 ⁽¹⁾	740	680	800					725	1722	1512	1902	603	694	413	50				
BX 355MBK																								
BX 355MCK														1827	1617	2082								

HINWEIS: (1) Diese Maße betreffen das zweite Zweite Wellenverlängerung (PS). (2) Der Sechskant ES ist bei der Option PS nicht vorhanden.

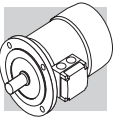

BX - IM B14 - FD/FA - CUS/NBR

BX-MX

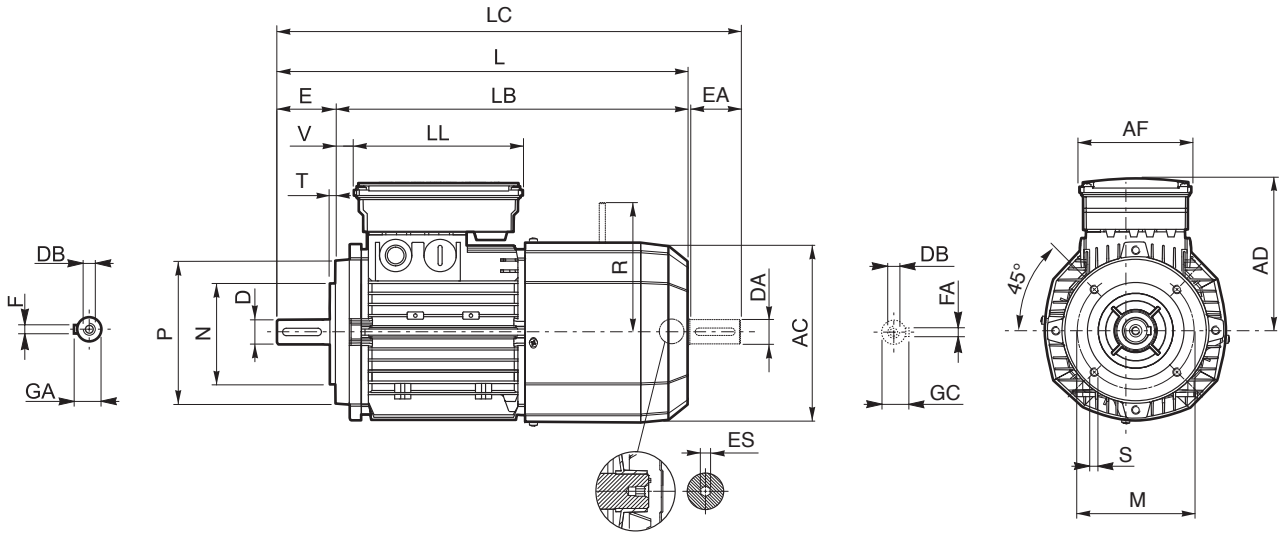

	Welle					Gehäuse					Motor												
	D	E	DB	GA	F	M	N	P	S	T	AC	L	LB	LC	AD	AF	LL	V	R		ES ⁽²⁾		
	DA	EA	M	GC	FA														FD	FA			
BX 90 SR	19 19 ⁽¹⁾	40 40 ⁽¹⁾	M6 M6 ⁽¹⁾	21.5 21.5 ⁽¹⁾	6 6 ⁽¹⁾	100	80	120	M6			400		442									
BX 90 S	24 19 ⁽¹⁾	50 40 ⁽¹⁾	M8 M6 ⁽¹⁾	27 21.5 ⁽¹⁾	8 6 ⁽¹⁾	115	95	140		3	176		360		146			32		129	134		
BX 90 LA												410		452			110	165					
BX 100 LA									M8											160	160		
BX 100 LB	28 24 ⁽¹⁾	60 50 ⁽¹⁾	M10 M8 ⁽¹⁾	31 27 ⁽¹⁾	8 8 ⁽¹⁾	130	110	160		3.5	195	502	442	554	155			37				6	
BX 112 M											219	527	467	579	170			39		199	198		
BX 132 SB	38 28 ⁽¹⁾	80 60 ⁽¹⁾	M12 M10 ⁽¹⁾	41 31 ⁽¹⁾	10 8 ⁽¹⁾	165	130	200	M10	4	258	661	581	724	210	140	188	46			200		
BX 132 MA																					226		

HINWEIS: (1) Diese Maße betreffen das zweite Zweite Wellenverlängerung (PS). (2) Der Sechskant ES ist bei der Option PS nicht vorhanden.



MX

BX-MX

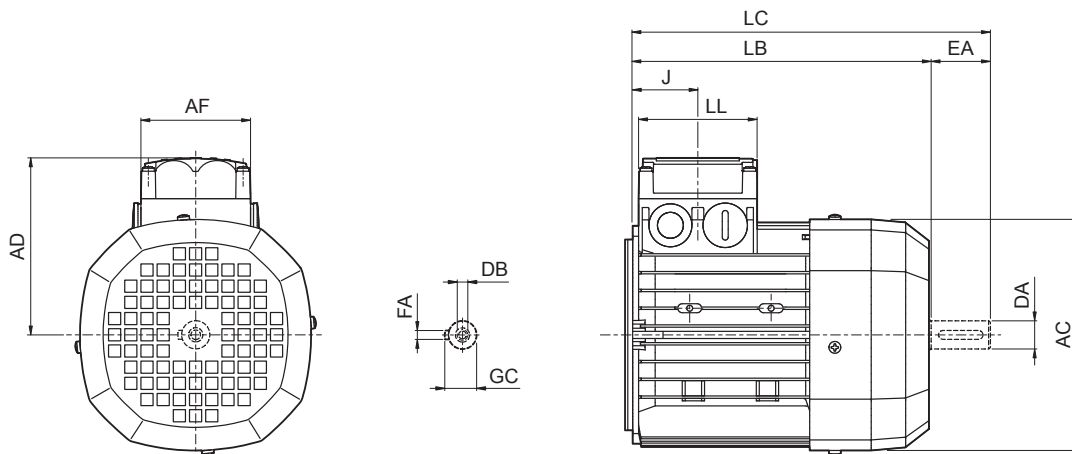

	Zweite Wellenende					Motor						
	DA	EA	DB	GC	FA	AC	LB	LC	AF	LL	J	AD
MX 2SB	14	30	M5	16	5	156	246	278	74	80	44	119
MX 3SA	24	50	M8	27	8	195	265	317	98	98	53.5	142
MX 3SB							305	357				
MX 3LA												
MX 3LB												
MX 4SA	28	60	M10	31		258	361	424	118	118	64.5	193
MX 4SB							396	459				
MX 4LA												
MX 5SA	38	80	M12	41	10	310	418	502	187	187	77	245
MX 5SB							462	546				
MX 5LA												

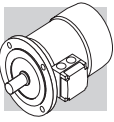

MX_FD/FA

BX-MX

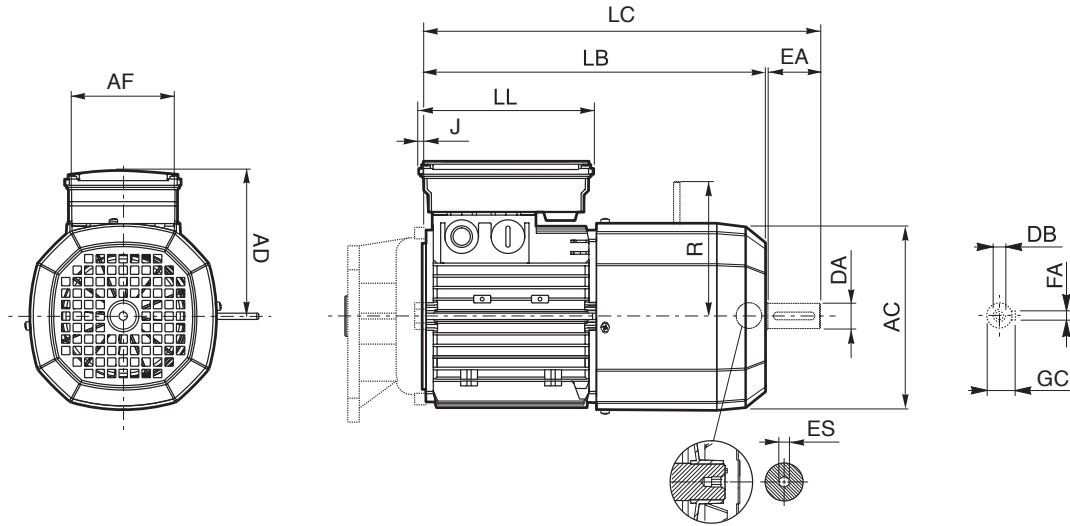

	Zweite Wellenende					Motor									
	DA	EA	DB	GC	FA	AC	LB	LC	AF	LL	J	AD	R	FD	FA
MX 2SB	14	30	M5	16	5	156	318	349	98	133	9	143	129	134	5
MX 3SA	24	50	M8	27	8	195	355	407	110	165	7	155	160	160	6
MX 3SB							397	450							
MX 3LA															
MX 3LB	28	60	M10	31	258	470	534	140	188	210	204	200			
MX 4SA						494	558					226			
MX 4LB															
MX 5SA	38	80	M12	41	10	310	558	644	187	187	17	245	266	247	—
MX 5SB							602	686							
MX 5LA															

HINWEIS:

(1) Der Sechskant ES ist bei der Option PS nicht vorhanden.



MX CUS

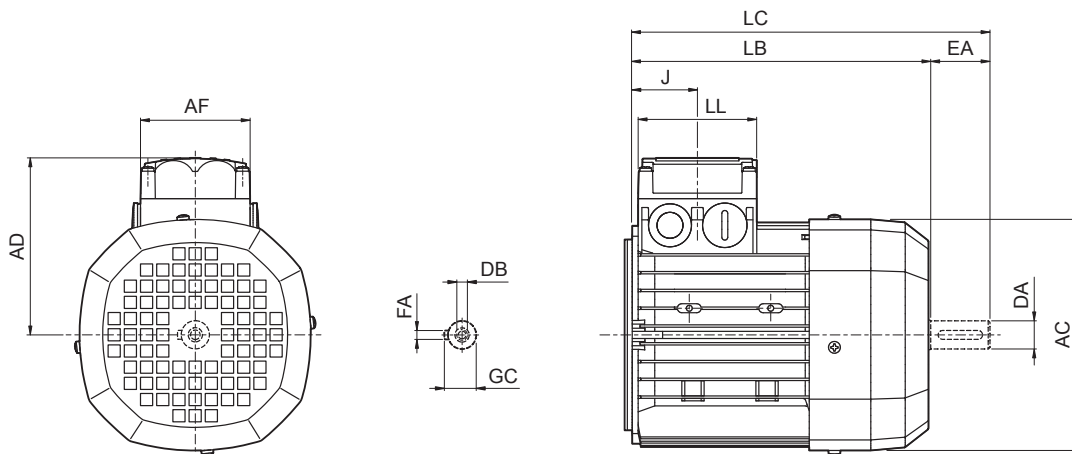

	Zweite Wellenende					Motor						
	DA	EA	DB	GC	FA	AC	LB	LC	AF	LL	J	AD
MX 2SB	14	30	M5	16	5	176	262	293	98	98	79	133
MX 3SA	24	50	M8	27	8	195	265	317				
MX 3SB							305	357				
MX 3LA												
MX 3LB												
MX 4SA	28	60	M10	31		258	361	424	118	118	64.5	193
MX 4SB							420	483				
MX 4LA												
MX 5SA	38	80	M12	41	10	310	418	502	187	187	77	245
MX 5SB							462	546				
MX 5LA												

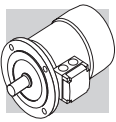

MX_FD/FA_CUS

BX-MX

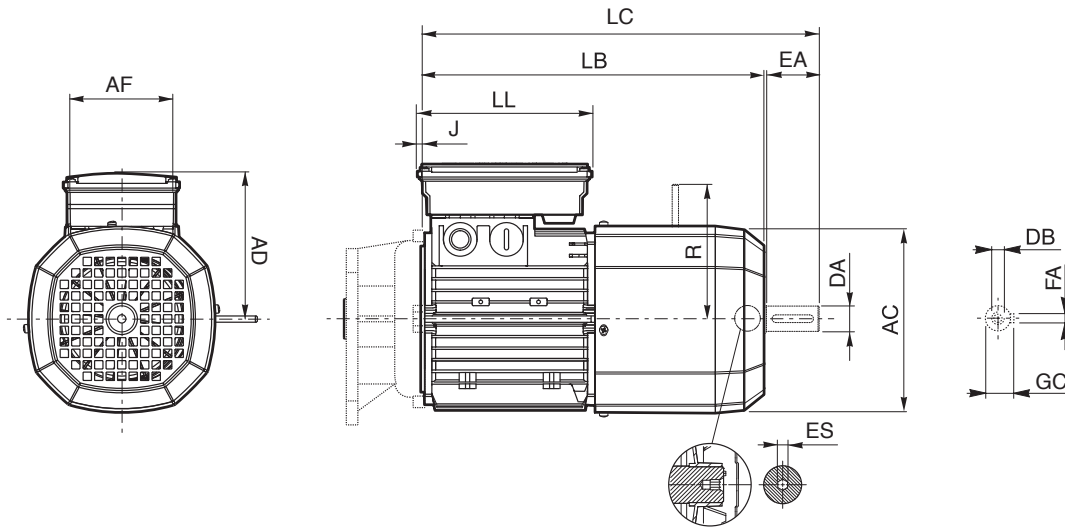

	Zweite Wellenende					Motor										
	DA	EA	DB	GC	FA	AC	LB	LC	AF	LL	J	AD	R FD FA		ES ⁽¹⁾	
MX 2SB	14	30	M5	16	5	176	347	379	110	165	-17	146	129	134	6	
MX 3SA	24	50	M8	27	195	355	407									
MX 3SB						397	450									
MX 3LA																
MX 3LB	8	28	60	M10	31	258	470	534	140	188	210	204	200			
MX 4SA	528						592	226								
MX 4SB																
MX 4LA	38	80	M12	41	10	310	558	644	187	187	17	245	266	247		—
MX 5SA							602	686								
MX 5SB																
MX 5LA																

HINWEIS:

(1) Der Sechskant ES ist bei der Option PS nicht vorhanden.

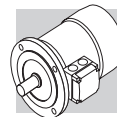

M18 MOTORENAUSWAHLTABELLEN BE-ME



2 P	3000 min ⁻¹ - S1														50 Hz - IE2											
	G.S. Bremse														W.S. Bremse											
	P _n kW	n min ⁻¹	M _n Nm	I _n 400V A	η%		cos φ	I _s I _n	M _s M _n	M _a M _n	J _m x 10 ⁻⁴ kgm ²	IM B5 Kg	Mod	M _b Nm	Z _o 1/h	NB	SB	Z _o 1/h	J _m x 10 ⁻⁴ kgm ²	IM B5 Kg	Mod	M _b Nm	Z _o 1/h	J _m x 10 ⁻⁴ kgm ²	IM B5 Kg	
100%					75%	50%																				FA
0.75	BE 80A	2	2860	2.5	1.65	80	79.6	76.4	0.83	6.8	3.8	3.5	9	9.5	FD 04	5	1700	3200	9.4	13.4	FA 04	5	3200	9.4	13.3	
1.1	BE 80B	2	2845	3.7	2.35	81.5	82.2	79.9	0.83	6.9	3.8	3.1	11.4	11.3	FD 04	10	1500	3000	10.6	15.2	FA 04	10	3000	10.6	15.1	
1.5	BE 90SA	2	2865	5	3.2	81.3	80.7	78.1	0.82	6.8	3.6	2.8	12.5	12.3	FD 14	15	900	2200	14.1	16.5	FA 14	15	2200	14.1	16.4	
2.2	BE 90L	2	2870	7.3	4.7	83.2	83.1	80.8	0.82	6.9	3.1	2.9	16.7	14	FD 05	26	900	2200	21	20	FA 05	26	2200	21	20.7	
3	BE 100L	2	2880	9.9	6.2	84.6	84.6	83.7	0.83	7.3	3.5	3.1	39	23	FD 15	26	700	1600	35	29	FA 15	26	1600	35	30	
4	BE 112M	2	2920	13.1	8.2	85.8	85.5	84.3	0.82	7.9	3.5	3.1	57	28	FD 06S	40	—	950	66	39	FA 06S	40	950	66	40	
5.5	BE 132SA	2	2925	18	10.6	87	85	81.7	0.86	8.5	3.6	3.3	145	42	FD 06	50	—	600	112	55	FA 06	50	600	112	56	
7.5	BE 132SB	2	2935	24	14.3	88.1	87.4	84.7	0.86	8.8	3.9	3.6	178	53	FD 06	50	—	550	154	66	FA 06	50	550	154	67	
9.2	BE 132MB	2	2920	30	16.4	88.8	86.5	84.2	0.91	8.4	3.7	3.3	210	65	FD 56	75	—	430	189	78	FA 06	75	430	189	79	
11	BE 160MA	2	2940	36	20	89.4	89.5	88	0.89	8.1	3	2.9	340	84	—	—	—	—	—	—	—	—	—	—	—	—
15	BE 160MB	2	2950	49	27.2	90.5	90.5	89.5	0.88	8.5	3	2.8	420	97	—	—	—	—	—	—	—	—	—	—	—	—
18.5	BE 160L	2	2945	60	32	90.9	90.5	89.8	0.91	7.7	2.9	2.7	490	109	—	—	—	—	—	—	—	—	—	—	—	—

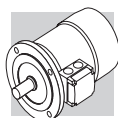







4 P		1500 min ⁻¹ - S1											50 Hz - IE2												
P _n kW	CE A068744	n min ⁻¹	M _n Nm	I _n 400V A	η%			cos φ	I _s I _n	M _s M _n	M _a M _n	J _m x 10 ⁻⁴ kgm ²	IM B5 Kg	G.S. Bremse				W.S. Bremse							
					100%	75%	50%							FD		FA									
					M _b Nm	Z ₀ 1/h	NB							SB	M _b Nm	Z ₀ 1/h	J _m x 10 ⁻⁴ kgm ²	IM B5 Kg	Mod	M _b Nm	Z ₀ 1/h	J _m x 10 ⁻⁴ kgm ²	IM B5 Kg	Mod	
0.12	BE 63A	4	1360	0.84	0.45	59.1	59.6	53.5	0.65	3	2.2	2.3	3.5	FD 02	10000	13000	2.6	5.2	FA 02	1.75	13000	2.6	5.2		
0.18	BE 63B	4	1370	1.25	0.64	64.7	65.1	59.8	0.62	3.5	2.5	3.3	5.1	FD 02	10000	13000	3	5.6	FA 02	3.5	13000	3	5.4		
0.25	BE 71A	4	1380	1.73	0.68	68.5	68	62	0.78	4	2.5	5.8	5.1	FD 03	7700	11000	6.9	7.8	FA 03	3.5	11000	6.9	7.5		
0.37	BE 71B	4	1385	2.55	1.05	72.7	69.3	64.2	0.75	4.0	2.2	6.9	5.9	FD 03	7700	11000	6.9	7.8	FA 03	3.5	11000	6.9	7.5		
0.55	BE 80A	4	1430	3.7	1.38	77.1	73.4	68	0.77	6	2.2	15	8.2	FD 04	4100	8000	16.6	13.8	FA 04	10	8000	16.6	13.7		
0.75	BE 80B	4	1430	5	1.76	79.6	78.5	75.1	0.78	6.1	3.2	28	12.2	FD 04	4100	8000	22	16.1	FA 04	15	8000	22	16		
1.1	BE 90S	4	1430	7.4	2.53	81.4	82	79.5	0.76	6.3	2.9	28	13.6	FD 14	4800	8000	32	17.8	FA 14	15	8000	32	17.7		
1.5	BE 90LA	4	1430	10	3.5	82.8	83	80	0.74	5.9	3	34	15.1	FD 05	3400	6000	34	21.1	FA 05	26	6000	34	21.8		
2.2	BE 100LA	4	1430	14.7	4.9	84.3	85	84	0.76	5.8	3	54	22	FD 15	2600	4700	44	29	FA 15	40	4700	44	29		
3	BE 100LB	4	1420	20	6.6	85.5	86	85.5	0.77	5.9	2.8	61	24	FD 15	2400	4400	58	31	FA 15	40	4400	58	31		
4	BE 112M	4	1440	27	8.3	86.6	87	86	0.8	6.5	2.8	105	32	FD 06S	—	1400	107	42	FA 06S	60	2100	107	44		
5.5	BE 132S	4	1460	36	11.1	88.5	88.5	87.5	0.81	7.3	2.9	270	53	FD 56	—	1050	223	66	FA 06	75	1200	223	67		
7.5	BE 132MA	4	1460	49	14.8	89	89	88.5	0.82	6.9	2.8	319	59	FD 06	—	950	280	72	FA 06	100	1000	280	77		
9.2	BE 132MB	4	1460	60	18.1	89.5	89.5	88.5	0.82	6.9	3	360	70	FD 07	—	900	342	86	FA 07	150	900	342	87		
11	BE 160M	4	1465	72	21.5	91	91.3	90.5	0.81	6.5	2.6	650	99	FD 08	—	800	655	129	FA 08	170	800	655	128		
15	BE 160L	4	1465	98	28.7	90.8	91	90.5	0.83	6.5	2.6	790	115	FD 08	—	750	725	129	FA 08	200	750	710	128		
18.5	BE 180M	4	1465	121	35	91.6	92	91.3	0.83	6.5	2.5	1250	135	FD 09	—	400	1450	175	—	—	—	—	—	—	
22	BE 180L	4	1465	143	41	91.6	91.8	91.4	0.84	6.8	2.6	1650	157	FD 09	—	300	1850	197	—	—	—	—	—	—	—

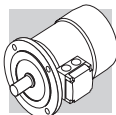

6 P		1000 min ⁻¹ - S1												50 Hz - IE2										
  A068744		G.S. Bremse												W.S. Bremse										
		FD												FA										
		P _n	n	M _n	In	100%	75%	50%	cos φ	$\frac{I_s}{I_n}$	$\frac{M_s}{M_n}$	$\frac{M_a}{M_n}$	J _m	IM B5	Mod	M _b	Z ₀	J _m	IM B5	Mod	M _b	Z ₀	J _m	IM B5
kW	min ⁻¹	Nm	A	100%	75%	50%					kgm ²	kg		Nm	1/h	kgm ²	kg		Nm	1/h	kgm ²	kg		
0.75	BE 90S	6	935	7.7	2.06	75.9	73	0.69	5.1	3.1	2.9	33	15	FD 14	15	3400	6500	28	19.2	FA 14	15	6500	28	19.1
1.1	BE 100M	6 (*)	945	11.1	2.75	78.1	73	0.74	4.9	2.2	1.9	82	22	FD 15	26	2500	4800	58	30	FA 15	26	4800	58	31
1.5	BE 100LA	6	945	15.2	3.9	79.8	74	0.72	5.6	2.5	2.3	95	24	FD 15	40	1900	4100	86	30	FA 15	40	4100	86	31
2.2	BE 112M	6	950	22	5.2	81.8	79.3	0.74	5.2	2.6	2.3	168	32	FD 06S	60	—	2100	177	42	FA 06S	60	2100	177	44
3	BE 132S	6	955	30	6.6	83.3	82.4	0.79	6.1	2.1	1.9	295	44	FD 56	75	—	1400	226	57	FA 06	75	1400	226	58
4	BE 132MA	6	965	40	8.7	84.6	83.1	0.79	6.9	2.2	2	383	56	FD 06	100	—	1200	305	69	FA 07	100	1200	318	74
5.5	BE 160MA	6 (*)	965	54	11.6	87	86.4	0.79	6.6	2.5	2.3	740	83	FD 08	170	—	1000	700	112	FA 08	170	1000	700	113
7.5	BE 160MB	6 (*)	965	74	15	88	87.2	0.82	6.6	2.3	2.1	970	103	FD 08	170	—	900	815	132	FA 08	170	900	815	133

(*) Das Verhältnis Leistung / Größe ist nicht genormt



2 P		3000 min ⁻¹ - S1												50 Hz - IE2									
P _n kW		n min ⁻¹	M _n Nm	I _n 400V A	η%		cos φ	$\frac{I_s}{I_n}$	$\frac{M_s}{M_n}$	$\frac{M_a}{M_n}$	J _m x 10 ⁻⁴ kgm ²	IM B5 	G.S. Bremse				W.S. Bremse						
					100%	75%							FD		FA								
					100%	75%							M _b Nm	Z ₀ 1/h	NB	SB	J _m x 10 ⁻⁴ kgm ²	IM B5 	Mod	M _b Nm	Z ₀ 1/h	J _m x 10 ⁻⁴ kgm ²	IM B5 
0.75	BE 80A	2	2.5	1.65	80	79.6	0.83	6.8	3.8	3.5	9	9.5	FD 04	5	1700	3200	9.4	12.5	FA 04	5	3200	9.4	12.4
1.1	BE 80B	2	3.7	2.35	81.5	82.2	0.83	6.9	3.8	3.1	11.4	11.3	FD 04	10	1500	3000	10.6	13.4	FA 04	10	3000	10.6	13.3
1.5	BE 90SA	2	5	3.2	81.3	80.7	0.82	6.8	3.6	2.8	12.5	12.3	FD 14	15	900	2200	14.1	16.5	FA 14	15	2200	14.1	16.4
2.2	BE 90L	2	7.3	4.7	83.2	83.1	0.82	6.9	3.1	2.9	16.7	14	FD 05	26	900	2200	21	20	FA 05	26	2200	21	20.7
3.7	BE 112M	2	12.1	7.8	85.5	83	0.79	7.9	3.5	3.1	57	28	FD 06S	40	—	950	66	39	FA 06S	40	950	66	40



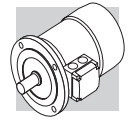





4 P	1500 min⁻¹ - S1		50 Hz - IE2	
------------	-----------------------------------	--	--------------------	--

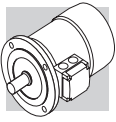

P _n kW		G.S. Bremse											W.S. Bremse													
		FD											FA													
		IM B5	J _m x 10 ⁻⁴ kgm ²	M _a /M _n	M _s /M _n	I _s /I _n	cos φ	η%	In 400V A	M _n Nm	n min ⁻¹	M _b Nm	Z ₀ 1/h	J _m x 10 ⁻⁴ kgm ²	IM B5	M _b Nm	Z ₀ 1/h	J _m x 10 ⁻⁴ kgm ²	IM B5							
0.37	BE 71B	4	1385	2.55	1.05	72.7	69.3	75%	50%	0.75	4.0	2.3	2.2	6.9	5.9	FD 03	5	6000	9400	8	8.6	FA 03	5	9400	8	8.3
0.55	BE 80A	4	1430	3.7	1.38	77.1	73.4	68	0.77	6	2.2	1.9	15	9.9	FD 04	10	4100	8000	16.6	13.8	FA 04	10	8000	16.6	13.7	
0.75	BE 80B	4	1430	5	1.76	79.6	78.5	75.1	0.78	6.1	3.2	3	28	12.2	FD 04	15	4100	7800	22	16.1	FA 04	15	7800	22	16	
1.1	BE 90S	4	1430	7.4	2.53	81.4	82	79.5	0.76	6.3	2.9	2.8	28	13.6	FD 14	15	4800	8000	32	17.8	FA 14	15	8000	32	17.7	
1.5	BE 90LA	4	1430	10	3.5	82.8	83	80	0.74	5.9	3.1	3	34	15.1	FD 05	26	3400	6000	34	21.1	FA 05	26	6000	34	21.8	
2.2	BE 100LA	4	1430	14.7	4.9	84.3	85	84	0.76	5.8	3	2.8	54	22	FD 15	40	2600	4700	44	29	FA 15	40	4700	44	29	
3.7	BE 112M	4	1445	27	8.2	86.3	87	84.3	0.76	6.5	2.8	2.8	105	32	FD 06S	60	—	1400	107	42	FA 06S	60	2100	107	44	



6 P		1000 min ⁻¹ - S1											50 Hz - IE2								
P _n kW	 BE 90S BE 100M 6 (*) BE 100LA 6 BE 112M 6 BE 132MA 6	n min ⁻¹	M _n Nm	I _n 400V A	η%		cos φ	I _s I _n	M _s M _n	M _a M _n	J _m x 10 ⁻⁴ kgm ²	IM B5 	G.S. Bremse				W.S. Bremse				
					100%	75%							FD		FA						
													M _b Nm	Z ₀ 1/h	J _m x 10 ⁻⁴ kgm ²	IM B5 	M _b Nm	Z ₀ 1/h	J _m x 10 ⁻⁴ kgm ²	IM B5 	
0.75	BE 90S	6	935	7.7	2.06	75.9	75.9	0.69	5.1	3.1	2.9	33	15	3400	6500	28	16.8	15	6500	28	16.7
1.1	BE 100M 6 (*)	6	945	11.1	2.75	78.1	76.2	0.74	4.9	2.2	1.9	82	22	1900	4100	86	28	40	4100	86	29
1.5	BE 100LA 6	6	945	15.2	3.9	79.8	77.5	0.72	5.6	2.5	2.3	95	24	1700	3600	99	30	40	3600	99	31
2.2	BE 112M 6	6	950	22	5.2	81.8	81.8	0.74	5.2	2.6	2.3	168	32	—	2100	177	42	60	2100	177	44
3.7	BE 132MA 6	6	970	36.1	8.3	84.3	83.6	0.76	6.9	2.2	2	383	56	—	1200	305	58	100	1200	318	63

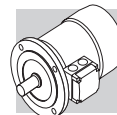

(*) Das Verhältnis Leistung / Größe ist nicht genormt



4 P		1800 min ⁻¹ - S1										60 Hz - IE2													
P _n HP kW		G.S. Bremse										W.S. Bremse													
		FD										FA													
		M _b	Mod	Z ₀	J _m x 10 ⁻⁴	IM B5	M _b	Mod	Z ₀	J _m x 10 ⁻⁴	IM B5	M _b	Mod	Z ₀	J _m x 10 ⁻⁴	IM B5									
Nm		NB	SB	kgm ²	kg	Nm		NB	SB	kgm ²	kg	Nm		NB	SB	kgm ²	kg								
0.75	0.55	BE 80A	4	1740	3	1.23	75.5	73.1	66.8	0.74	8.7	3.8	3.0	N	19	9.9	4100	8000	16.6	13.8	FD 04	10	8000	16.6	13.7
1	0.75	BE 80B	4	1745	4.1	1.46	82.5	81.1	77.6	0.78	7.6	3.5	3.2	K	28	12.2	4100	7800	22	16.1	FA 04	15	7800	22	16
1.5	1.1	BE 90S	4	1740	6	2.25	84	82.7	79	0.73	7.7	3.5	3.2	L	28	13.6	4800	8000	32	17.8	FA 14	15	8000	32	17.7
2	1.5	BE 90LA	4	1740	8.2	3.1	84.5	83.9	80.7	0.73	7.1	3.6	3.4	K	34	15.1	3400	6000	34	21.1	FA 05	26	6000	34	21.8
3	2.2	BE 100LA	4	1745	12	4.2	87.5	85.5	83.2	0.76	7	3.3	2.9	J	54	22	2600	4700	44	29	FA 15	40	4700	44	29
4	3	BE 100LB	4	1735	16.5	5.9	87.5	87.7	86.3	0.76	7	3.2	2.9	K	61	24	2400	4400	58	31	FA 15	40	4400	58	31
5	3.7	BE 112M	4	1750	20	6.6	87.5	87.5	86.1	0.8	7.8	3.3	3.2	K	105	32	—	1400	107	42	FA 06S	60	2100	107	44
7.5	5.5	BE 132S	4	1760	30	9.3	89.5	89.5	87.7	0.83	8.7	3.5	3.5	K	270	53	—	1050	223	66	FA 06	75	1200	223	67
10	7.5	BE 132MA	4	1760	43	12.7	89.5	89.5	87.9	0.83	8	3.4	3.3	K	319	59	—	950	280	72	FA 06	100	1000	280	77
12.5	9.2	BE 132MB	4	1760	50	15.6	90	90	88.6	0.82	8.3	3.5	3.6	K	360	70	—	900	342	86	FA 07	150	900	342	87
15	11	BE 160M	4	1765	60	18.7	91	91	90	0.81	7.7	2.9	2.8	J	650	99	—	800	655	129	FA 08	170	800	655	128
20	15	BE 160L	4	1770	81	25.5	91	90.5	89.5	0.81	7.1	3.1	2.7	J	790	115	—	750	725	129	FA 08	200	750	710	128
25	18.5	BE 180M	4	1765	100	30.3	92.4	91.9	90.5	0.83	7.3	2.7	2.5	H	1250	135	—	400	1450	175	—	—	—	—	—
30	22	BE 180L	4	1770	119	36	92.4	92.5	92.2	0.83	8.1	3.3	3.2	J	1650	157	—	300	1850	197	—	—	—	—	—

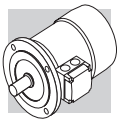



2 P		3000 min ⁻¹ - S1												50 Hz - IE2					
  A068744		G.S. Bremse												W.S. Bremse					
		FD												FA					
		P _n	In	M _n	n	M _n	I _n	M _s	M _a	J _m	IM B5	Mod	M _b	Z ₀	J _m	IM B5	Mod	M _b	Z ₀
kW	A	Nm	min ⁻¹	Nm	A	Nm	Nm	kgm ²	kg		Nm	1/h	kgm ²	kg		Nm	1/h	kgm ²	kg
0.75	1.63	2.5	2860	2.5	1.63	3.8	3.5	9	8.8	FD 04	5	1700	9.4	12.7	FA 04	5	3200	9.4	12.6
1.1	2.35	3.7	2845	3.7	2.35	3.8	3.1	11.4	10.6	FD 04	10	1500	13	14.5	FA 04	10	3000	13	14.4
1.5	3.2	5.0	2845	5.0	3.2	2.9	2.7	24	15.5	FD 15	13	1300	22	22	FA 15	26	2600	22	23
2.2	4.7	7.3	2895	7.3	4.7	2.7	2.5	31	18.7	FD 15	26	1100	28	25.2	FA 15	26	2400	28	26.2
3	6.2	9.9	2880	9.9	6.2	3.5	3.1	39	22	FD 15	26	700	35	28.5	FA 15	26	1600	35	29.5
4	7.8	13.2	2900	13.2	7.8	2.9	2.8	101	33	FD 06	50	—	107	46	FA 06	50	2100	107	47
5.5	10.6	18.0	2925	18.0	10.6	3.6	3.3	145	40	FD 06	50	—	112	48	FA 06	50	600	112	49
7.5	14.3	24	2935	24	14.3	3.9	3.6	178	51	FD 06	50	—	154	55	FA 06	50	550	154	56
9.2	16.4	30	2920	30	16.4	3.7	3.3	210	60	FD 56	75	—	189	66	FA 06	75	430	189	67
11	20.0	36	2940	36	20.0	3.0	2.9	340	70										
15	27.2	49	2950	49	27.2	3.0	2.8	420	83										
18.5	32	60	2945	60	32	2.9	2.7	490	95										

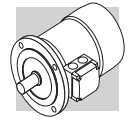



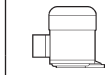

4 P	1500 min⁻¹ - S1	50 Hz - IE2
------------	-----------------------------------	--------------------

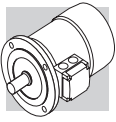

P _n kW	n min ⁻¹	M _n Nm	I _n 400V A	η%			cos φ	I _s I _n	M _s M _n	M _a M _n	J _m x 10 ⁻⁴ kgm ²	IM B5 Kg	G.S. Bremse						W.S. Bremse												
				100%	75%	50%							FD			FA			FD			FA									
													M _b Nm	Z ₀ 1/h	NB	SB	Mod	IM B5 Kg	J _m x 10 ⁻⁴ kgm ²	Z ₀ 1/h	M _b Nm	Mod	IM B5 Kg	J _m x 10 ⁻⁴ kgm ²	Z ₀ 1/h	M _b Nm	Mod	IM B5 Kg	J _m x 10 ⁻⁴ kgm ²	Z ₀ 1/h	M _b Nm
0.12	1360	0.84	0.45	59.1	59.6	53.5	0.65	3	2.2	2.3	3.5	FD 02	10000	13000	10000	13000	1.75	FA 02	5.2	2.6	13000	1.75	FA 02	5.2	2.6	13000	1.75	FA 02	5.2	2.6	13000
0.18	1370	1.25	0.64	64.7	65.1	59.8	0.62	3.5	2.5	3.3	5.1	FD 02	10000	13000	10000	13000	3.5	FA 02	5.6	3	13000	3.5	FA 02	5.6	3	13000	3.5	FA 02	5.6	3	13000
0.25	1380	1.73	0.68	68.5	68	62	0.78	4	2.5	5.8	5.1	FD 03	7700	11000	7700	11000	3.5	FA 03	7.8	6.9	11000	3.5	FA 03	7.8	6.9	11000	3.5	FA 03	7.8	6.9	11000
0.37	1385	2.55	1.05	72.7	69.3	64.2	0.75	4.0	2.2	6.9	5.9	FD 03	6000	9400	6000	9400	5	FA 03	8.6	8.0	9400	5	FA 03	8.6	8.0	9400	5	FA 03	8.6	8.0	9400
0.55	1430	3.7	1.38	77.1	73.4	68	0.77	6	2.2	15	9.9	FD 04	4100	8000	4100	8000	10	FA 04	13.8	16.6	8000	10	FA 04	13.8	16.6	8000	10	FA 04	13.8	16.6	8000
0.75	1430	5	1.76	79.6	78.5	75.1	0.78	6.1	3.2	28	12.2	FD 04	4100	7800	4100	7800	15	FA 04	16.1	22	7800	15	FA 04	16.1	22	7800	15	FA 04	16.1	22	7800
1.1	1430	7.4	2.53	82.5	82.0	79.5	0.76	6.3	2.9	28	15.5	FD 15	4800	8000	4800	8000	26	FA 15	21.5	32	8000	26	FA 15	21.5	32	8000	26	FA 15	21.5	32	8000
1.5	1420	10	3.5	83.5	83.0	80.0	0.74	5.9	3.1	34	17	FD 15	3400	6000	3400	6000	26	FA 15	23	34	6000	26	FA 15	23	34	6000	26	FA 15	23	34	6000
2.2	1430	14.7	4.9	84.3	85	84	0.76	5.8	3	54	21	FD 15	2600	4700	2600	4700	40	FA 15	27	44	4700	40	FA 15	27	44	4700	40	FA 15	27	44	4700
3	1420	20	6.6	85.5	86.0	85.5	0.77	5.9	2.8	61	23	FD 15	2400	4400	2400	4400	40	FA 15	29	58	4400	40	FA 15	29	58	4400	40	FA 15	29	58	4400
4	1440	27	8.3	87.0	87.0	86.0	0.80	6.5	2.8	105	42	FD 56	—	1400	—	1400	75	FA 06	55	107	1400	75	FA 06	55	107	1400	75	FA 06	55	107	1400
5.5	1460	36	11.1	88.5	88.5	87.5	0.81	7.3	2.9	270	51	FD 56	—	1050	—	1050	75	FA 06	64	223	1050	75	FA 06	64	223	1050	75	FA 06	64	223	1050
7.5	1460	49	14.8	89.0	89.0	88.5	0.82	6.9	2.9	319	57	FD 06	—	950	—	950	100	FA 07	70	280	950	100	FA 07	70	280	950	100	FA 07	70	280	950
9.2	1460	60	18.1	89.5	89.5	88.5	0.82	6.9	2.9	360	65	FD 07	—	900	—	900	150	FA 07	81	342	900	150	FA 07	81	342	900	150	FA 07	81	342	900
11	1465	72	21.5	91.0	91.3	90.5	0.81	6.5	2.8	650	85	FD 08	—	800	—	800	170	FA 08	115	655	800	170	FA 08	115	655	800	170	FA 08	115	655	800
15	1465	98	28.7	90.8	91.0	90.5	0.83	6.5	2.6	790	101	FD 08	—	750	—	750	200	FA 08	131	725	750	200	FA 08	131	725	750	200	FA 08	131	725	750



6 P		1000 min ⁻¹ - S1												50 Hz - IE2											
  A068744		G.S. Bremse												W.S. Bremse											
		FD												FA											
		P _n	n	M _n	I _n 400V	η%	cos φ	$\frac{I_s}{I_n}$	$\frac{M_s}{M_n}$	$\frac{M_a}{M_n}$	J _m x 10 ⁻⁴ kgm ²	IM B5 	Mod	M _b	Z ₀ 1/h	NB	SB	Z ₀ 1/h	M _b	Mod	M _b	Z ₀ 1/h	J _m x 10 ⁻⁴ kgm ²	IM B5 	
0.75	ME 3SA 6	7.6	1.98	75.9	75.0	0.72	4.7	2.2	2	33	17	FD 15	26	3400	6500	6500	28	26	FA 15	26	6500	28	21	FA 15	26
1.1	ME 3LA 6 (*)	11.1	2.75	78.1	76.2	0.74	4.9	2.2	1.9	82	21	FD 15	26	2700	5000	5000	37	26	FA 15	26	5000	37	27	FA 15	26
1.5	ME 3LB 6	15.2	3.8	79.8	77.5	0.72	5.6	2.5	2.3	95	23	FD 15	40	1900	4100	4100	86	40	FA 15	40	4100	86	29	FA 15	40
2.2	ME 4SA 6	22	4.9	81.8	81.8	0.80	5.7	1.9	1.7	216	34	FD 06	50	—	2100	2100	177	50	FA 06	50	2100	177	47	FA 06	50
3	ME 4SB 6	30	6.6	83.3	83.3	0.79	6.1	2.1	1.9	295	43	FD 56	75	—	1400	1400	226	75	FA 06	75	1400	226	56	FA 06	75
4	ME 4LA 6	40	8.6	84.6	85.0	0.79	6.9	2.2	2.0	383	54	FD 06	100	—	1200	1200	305	100	FA 07	100	1200	305	70	FA 07	100
5.5	ME 5SA 6 (*)	54	11.6	87.0	87.0	0.79	6.6	2.5	2.3	740	69	FD 08	170	—	1050	1050	406	170	FA 08	170	1050	406	99	FA 08	170
7.5	ME 5SB 6 (*)	74	15.0	88.0	88.0	0.82	6.6	2.3	2.1	970	89	FD 08	170	—	900	900	815	170	FA 08	170	900	815	119	FA 08	170

(*) Das Verhältnis Leistung / Größe ist nicht genormt





2 P	3000 min⁻¹ - S1	50 Hz - IE2
------------	-----------------------------------	--------------------

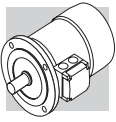

P _n kW	n min ⁻¹	M _n Nm	I _n 400V A	η%		cos φ	I _s I _n	M _s M _n	M _a M _n	J _m x 10 ⁻⁴ kgm ²	IM B5 Kg	G.S. Bremse				W.S. Bremse											
				100%	75%							FD		FA													
				100%	75%							M _b Nm	Z ₀ 1/h	NB	SB	M _b Nm	Z ₀ 1/h	Mod	IM B5 Kg	M _b Nm	Z ₀ 1/h	Mod	IM B5 Kg				
0.75	ME 2SA 2	2.5	1.63	80	79.6	0.83	6.8	3.8	3.5	9	8.8	FD 04	5	1700	3200	—	—	FD 04	5	3200	5	3200	FA 04	5	3200	9.4	12.7
1.1	ME 2SB 2	3.7	2.35	81.5	82.2	0.83	6.9	3.8	3.1	11.4	10.6	FD 04	10	1500	3000	—	—	FD 04	10	3000	10	3000	FA 04	10	3000	10.6	14.5
1.5	ME 3SA 2	5	3.2	81.3	79	0.81	6.1	2.9	2.7	24	15.5	FD 15	13	4800	8000	—	—	FD 15	26	6000	26	6000	FA 15	26	6000	32	22.5
2.2	ME 3LA 2	7.3	4.7	83.2	83.1	0.82	6.9	3.1	2.9	16.7	18.7	FD 15	26	3400	6000	—	—	FD 15	26	6000	26	6000	FA 15	26	6000	34	25.7
3.7	ME 4SA 2	12.1	7.8	84.7	83	0.79	7.9	3.5	3.1	57	33	FD 56	75	—	1400	—	—	FD 56	75	1400	75	2100	FA 06	75	2100	107	46



4 P		1500 min ⁻¹ - S1											50 Hz - IE2										
P _n kW		n min ⁻¹	M _n Nm	I _n 400V A	η%		cos φ	$\frac{I_s}{I_n}$	$\frac{M_s}{M_n}$	$\frac{M_a}{M_n}$	$\frac{J_m}{x 10^{-4}}$ kgm ²		G.S. Bremse						W.S. Bremse				
					100%	75%							Z _o 1/h		M _b Nm	Mod		FD			FA		
					50%	NB							SB	M _b				Z _o	J _m	M _b	Z _o	J _m	M _b
0.37	ME 1SB	4	2.55	1.05	72.7	69.3	0.75	4.0	2.3	2.2	6.9	5.9	6000	9400	8	8.6	5	9400	8	8.3			
0.55	ME 2SA	4	3.7	1.38	77.1	73.4	0.77	6	2.2	1.9	15	9.9	4100	8000	16.6	13.8	10	8000	16.6	13.7			
0.75	ME 2SB	4	5	1.76	79.6	78.5	0.78	6.1	3.2	3	28	12.2	4100	7800	22	16.1	15	7800	22	16			
1.1	ME 3SA	4	7.4	2.6	82.5	82	0.74	5.5	2.5	2.8	34	15.5	4800	8000	32	22.5	26	8000	32	22.5			
1.5	ME 3SB	4	10.1	3.48	84	84	0.74	6.2	2.9	2.9	40	17	3400	6000	34	24	26	6000	34	24			
2.2	ME 3LA	4	14.7	4.9	84.3	85	0.76	5.8	3	2.8	54	21	2600	4700	44	28	40	4700	44	28			
3.7	ME 4SA	4	27	8.25	87.5	86.8	0.80	7.1	3	3.1	213	42	—	1400	107	55	75	2100	107	56			





6 P		1000 min ⁻¹ - S1										50 Hz - IE2											
P _n kW	 IM B5 Kg	n min ⁻¹	M _n Nm	I _n 400V A	η%		cos φ	I _s I _n	M _s M _n	M _a M _n	J _m x 10 ⁻⁴ kgm ²	IM B5 Kg	G.S. Bremse				W.S. Bremse						
					100%	75%							FD		FA								
					100%	75%							M _b Nm	Z ₀ 1/h	NB	SB	M _b Nm	Z ₀ 1/h	J _m x 10 ⁻⁴ kgm ²	IM B5 Kg	Mod	M _b Nm	Z ₀ 1/h
0.75	ME 3SA 6	940	7.6	1.98	75.9	75	0.72	4.7	2.2	2	33	17	FD 15	26	3400	6500	28	21	FA 15	26	6500	28	22
1.1	ME 3LA 6 (*)	945	11.1	2.75	78.1	76.2	0.74	4.9	2.2	1.9	82	21	FD 15	26	2700	5000	37	27	FA 15	26	5000	37	28
1.5	ME 3LB 6	945	15.2	3.8	79.8	77.5	0.72	5.6	2.5	2.3	95	23	FD 15	40	1900	4100	86	29	FA 15	40	4100	86	30
2.2	ME 4SA 6	955	22	4.9	81.8	81.8	0.8	5.7	1.9	1.7	216	34	FD 56	75	—	2100	177	47	FA 06	60	2100	177	48
3.7	ME 4LA 6	970	36.1	8.3	83.5	83.6	0.76	6.9	2.2	2	383	54	FD 06	100	—	1200	305	70	FA 06	100	1200	305	72



(*) Das Verhältnis Leistung / Größe ist nicht genormt

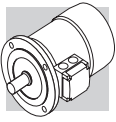

4 P		1800 min ⁻¹ - S1										60 Hz - IE2												
P _n		G.S. Bremse										W.S. Bremse												
		FD					FA																	
HP	kW	IM B5	J _m x 10 ⁻⁴	Z ₀ 1/h	M _b Nm	Mod	M _b Nm	Z ₀ 1/h	J _m x 10 ⁻⁴	IM B5	IM B5	J _m x 10 ⁻⁴	Z ₀ 1/h	M _b Nm	Mod	M _b Nm	Z ₀ 1/h	J _m x 10 ⁻⁴	IM B5					
0.75	0.55	ME 2SA	4	1740	3	1.23	75.5	73.1	66.8	0.74	8.7	3.8	3.0	N	FD 04	10	4100	8000	16.6	13.8	10	8000	16.6	13.7
1	0.75	ME 2SB	4	1745	4.1	1.46	82.5	81.1	77.6	0.78	7.6	3.5	3.2	K	FD 04	15	4100	7800	22	16.1	15	7800	22	16
1.5	1.1	ME 3SA	4	1740	6	2.25	84	82.7	79	0.73	7.7	3.5	3.2	J	FD 15	26	4800	8000	32	21.5	26	8000	32	22.5
2	1.5	ME 3SB	4	1740	8.2	3.1	84.5	83.9	80.7	0.73	7.1	3.6	3.4	K	FD 15	26	3400	6000	34	23	26	6000	34	24
3	2.2	ME 3LA	4	1745	12	4.2	87.5	85.5	83.2	0.76	7	3.3	2.9	J	FD 15	40	2600	4700	44	27	40	4700	44	28
4	3	ME 3LB	4	1735	16.5	5.9	87.5	87.7	86.3	0.76	7	3.2	2.9	K	FD 15	40	2400	4400	58	29	40	4400	58	30
5	3.7	ME 4SA	4	1750	20	6.6	87.5	87.5	86.1	0.8	7.8	3.3	3.2	J	FD 56	75	—	1400	107	55	75	2100	107	56
7.5	5.5	ME 4SB	4	1760	30	9.3	89.5	89.5	87.7	0.83	8.7	3.5	3.5	K	FD 56	75	—	1050	223	64	75	1200	223	65
10	7.5	ME 4LA	4	1760	43	12.7	89.5	89.5	87.9	0.83	8	3.4	3.3	K	FD 06	100	—	950	280	70	100	1000	280	75
12.5	9.2	ME 4LB	4	1760	50	15.6	90	90	88.6	0.82	8.3	3.5	3.6	K	FD 07	150	—	900	342	81	150	900	342	83
15	11	ME 5SA	4	1765	60	18.7	91	91	90	0.81	7.7	2.9	2.8	J	FD 08	170	—	800	655	115	170	800	655	114
20	15	ME 5LA	4	1770	81	25.5	91	90.5	89.5	0.81	7.1	3.1	2.7	J	FD 08	200	—	750	725	131	200	750	710	130





M19 MOTORENABMESSUNGEN BE-ME

BE - IM B5- CE/CUS/BIS/CCC

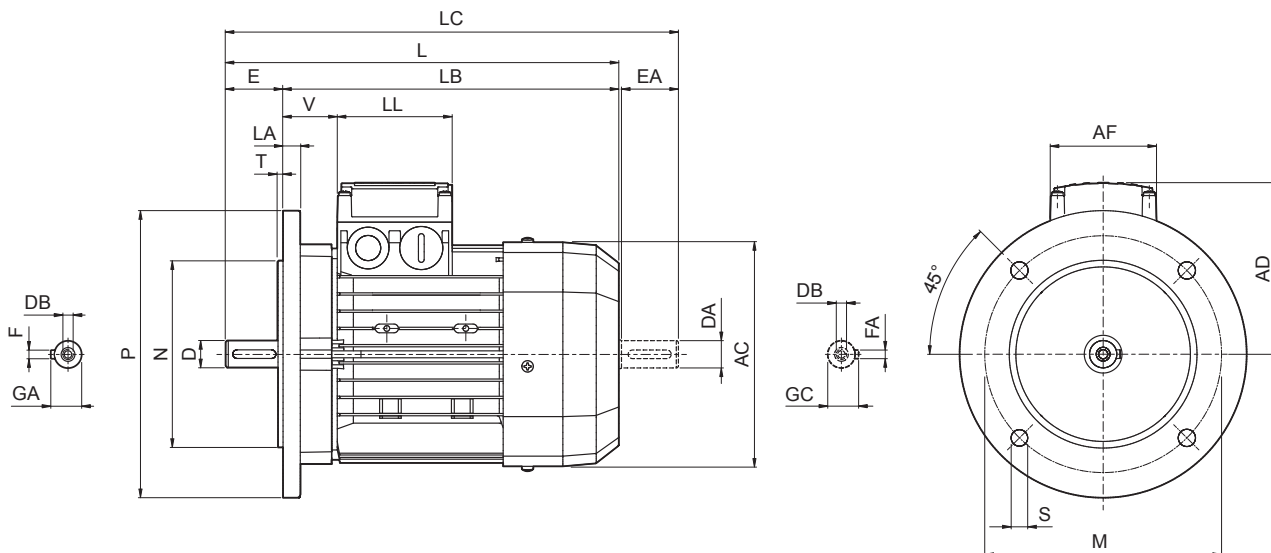

BE-ME

	Welle					Flansch						Motor							
	D DA	E EA	DB	GA GC	F FA	M	N	P	S	T	LA	AC	L	LB	LC	AD	AF	LL	V
BE 63	11	23	M4	12.5	4	115	95	140	9.5	3	10	121	207	184	232	95	74	80	26
BE 71	14	30	M5	16	5	130	110	160				138	249	219	281				
BE 80	19	40	M6	21.5	6	165	130	200	11.5	3.5	11.5	156	274	234	315	119	98	98	38
BE 90 S	24	50	M8	27	8							176	326	276	378	133			
BE 90 L						28	60	M10	31	215	180	250	14	195	367	307	429	142	98
BE 100	15	219	385	325	448														
BE 112	38	80	M12	41	10	265	230	300	14	4	20	258	493	413	576	193	118	118	58
BE 132 S													528	448	611				
BE 132 MA													596	486	680				
BE 132 MB	640	530	724																
BE 160 M	42	110	M16	45	12	300	250	350	18.5	5	15	310	596	486	680	245	187	187	51
BE 160 L	38 ⁽¹⁾	80 ⁽¹⁾	M12 ⁽¹⁾	41 ⁽¹⁾	10 ⁽¹⁾								640	530	724				
BE 180 M	48	110	M16	51.5	14	300	250	350	18.5	5	18	348	708	598	823	261	187	187	52
BE 180 L	42 ⁽¹⁾	110 ⁽¹⁾	M16 ⁽¹⁾	45 ⁽¹⁾	12 ⁽¹⁾								708	598	823				

HINWEIS: (1) Diese Maße betreffen das zweite Wellenverlängerung (PS).

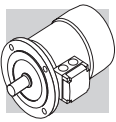

BE - IM B14- CE/CUS/BIS/CCC

BE-IME

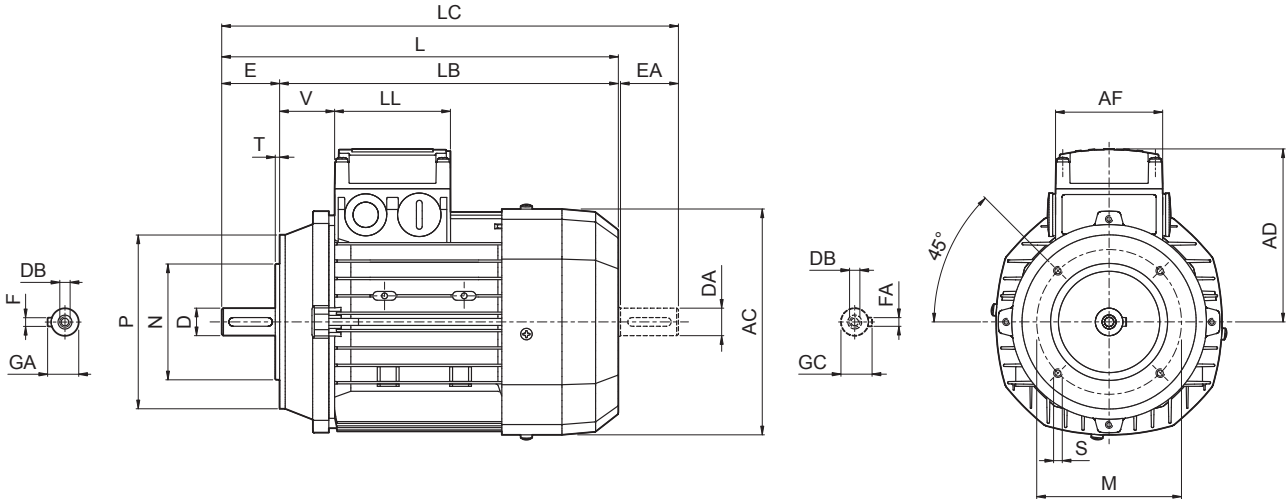

	Welle					Flansch					Motor							
	D DA	E EA	DB	GA GC	F FA	M	N	P	S	T	AC	L	LB	LC	AD	AF	LL	V
BE 63	11	23	M4	12.5	4	75	60	90	M5	2.5	121	207	184	232	95	74	80	37
BE 71	14	30	M5	16	5	85	70	105	M6	3	138	249	219	281	108			98
BE 80	19	40	M6	21.5	6	100	80	120			M8	3.5	156	274	234	315	119	
BE 90 S	24	50	M8	27	8	115	95	140	M8	3.5			176	326	276	378	133	98
BE 90 L						130	110	160			219	385	325	448	157	52		
BE 100	28	60	M10	31	8	130	110	160	M8	3.5	195	367	307	429	142	98	98	50
BE 112						219	385	325			448	157	52					
BE 132 S	38	80	M12	41	10	165	130	200	M10	4	258	493	413	576	193	118	118	58
BE 132 MA						528	448	611										
BE 132 MB						528	448	611										



BE - IM B5 - FD/FA - CE/CUS/BIS

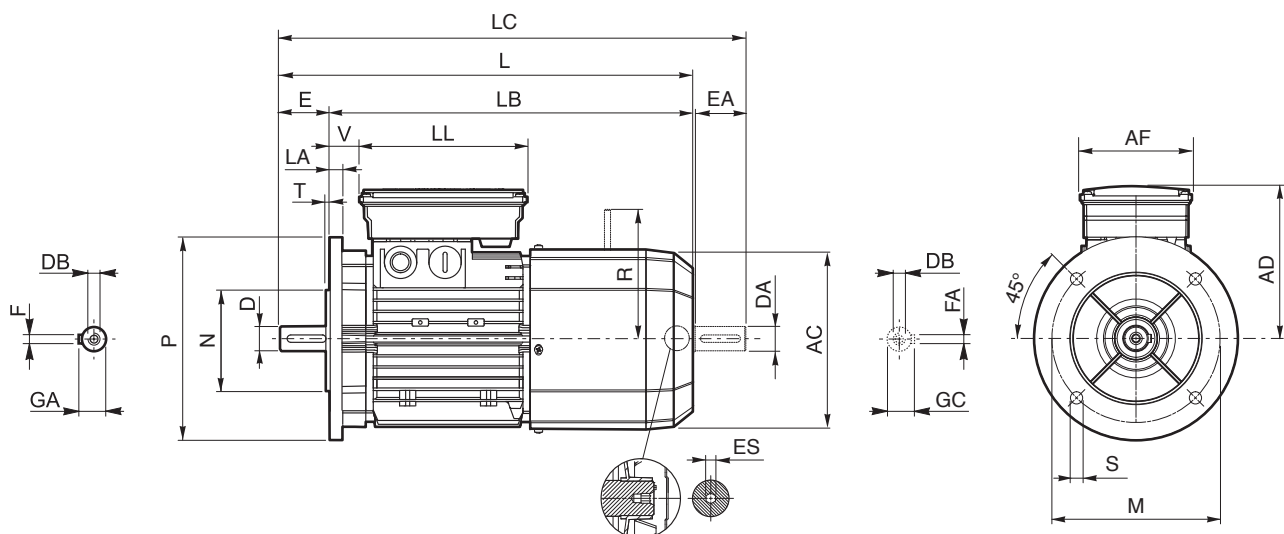

BE-ME

	Welle					Flansch						Motor										
	D DA	E EA	DB	GA GC	F FA	M	N	P	S	T	LA	AC	L	LB	LC	AD	AF	LL	V	R		ES ⁽²⁾
																				FD	FA	
BE 63	11	23	M4	12.5	4	115	95	140	9.5	3	10	121	272	249	297	122	98	133	14	96	116	5
BE 71	14	30	M5	16	5	130	110	160		10		138	313	283	345	135			24	103	124	
BE 80	19	40	M6	21.5	6	165	130	200	11.5	3.5	11.5	156	348	308	390	143	110	165	25	129	134	6
BE 90 S	24	50	M8	27	8							215	180	250	14	195			458	398	521	
BE 90 L						176	411	361	463	146	39						199	198				
BE 100	28	60	M10	31	8	215	180	250	14	195	458	398	521	155	37	160	160	39	199	198	6	
BE 112																						15
BE 132 S	38	80	M12	41	10	265	230	300	14	4	20	258	603	523	686	193	140	188	46	204	200	—
BE 132 MA													226	217								
BE 132 MB															628					548	711	
BE 160 M	42	110	M16	45	12	300	250	350	18.5	5	15	310	736	626	820	245	187	187	51	266	247	—
BE 160 L													38 ⁽¹⁾	80 ⁽¹⁾	M12 ⁽¹⁾							
BE 180 M	48	110	M16	51.5	14	300	250	350	18.5	5	18	348	866	756	981	261	187	187	52	305	—	—
BE 180 L																						

HINWEIS: (1) Diese Maße betreffen das zweite Zweite Wellenverlängerung (PS). (2) Der Sechskant ES ist bei der Option PS nicht vorhanden.

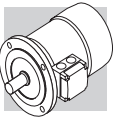

BE - IM B14 - FD/FA - CE/CUS/BIS

BE-IME

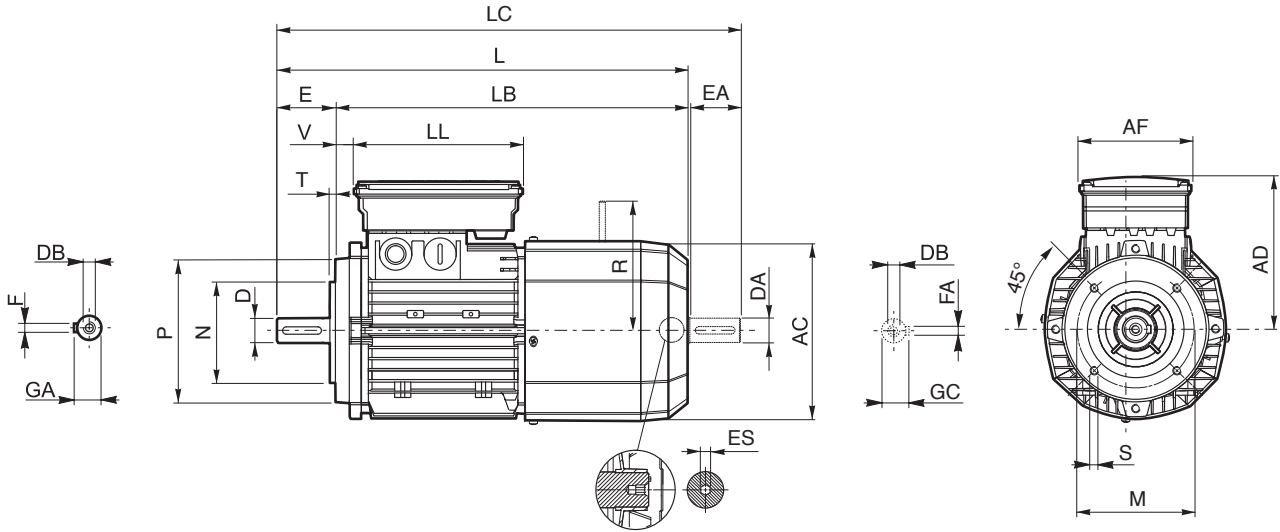

	Welle					Flansch					Motor										
	D DA	E EA	DB	GA GC	F FA	M	N	P	S	T	AC	L	LB	LC	AD	AF	LL	V	R		ES ⁽²⁾
																			FD	FA	
BE 63	11	23	M4	12.5	4	75	60	90	M5	2.5	121	272	249	297	122			14	96	116	5
BE 71	14	30	M5	16	5	85	70	105	M6	3	138	313	283	345	135	98	133	24	103	124	
BE 80	19	40	M6	21.5	6	100	80	120			156	348	308	390	143			25	129	134	
BE 90 S	24	50	M8	27	8	115	95	140	M8	3.5	176	411	361	463	146	110	165	32	160	160	6
BE 90 L																					
BE 100	28	60	M10	31	130	110	160	M10	4	258	603	523	686	193	140	188	46	204	200		
BE 112																				39	199
BE 132 S	38	80	M12	41	10	165	130	200	M10	4	258	628	548	711	193	140	188	46	226	217	—
BE 132 MA																					—
BE 132 MB																					—

HINWEIS: (2) Der Sechskant ES ist bei der Option PS nicht vorhanden.



ME - CE/CUS/BIS/CCC

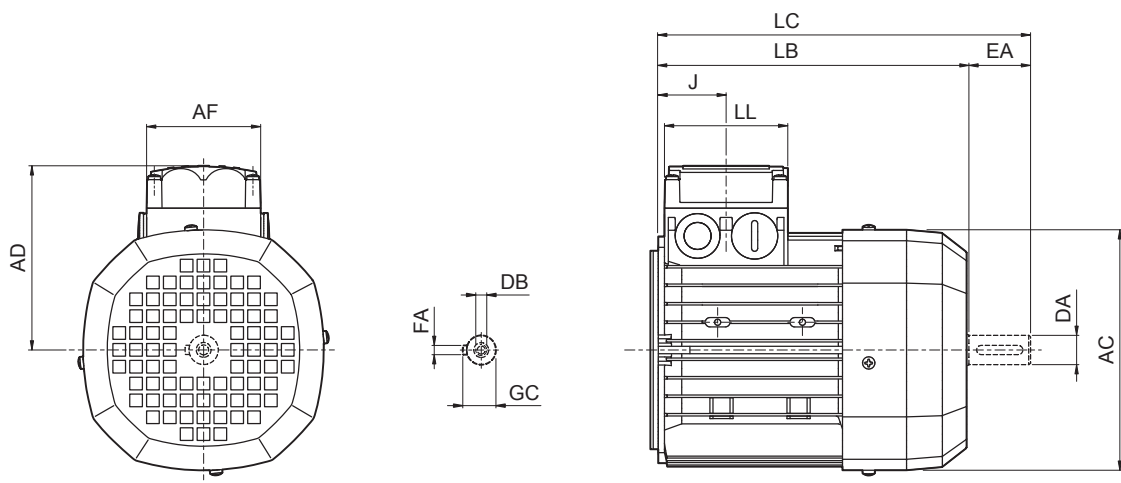

BE-ME

	Zweite Wellenende					Motor						
	DA	EA	DB	FA	GC	AC	LB	LC	AF	LL	J	AD
ME 05	11	23	M4	12.5	4	121	165	191	74	80	48	95
ME 1S	14	30	M5	16	5	138	187	219			45	108
ME 2S	19	40	M6	21.5	6	156	202	245			44	119
ME 3S	28	60	M10	31	8	195	230	293	98	98	53.5	142
ME 3L							262	325				
ME 4S	38	80	M12	41	10	258	361	444	118	118	64.5	193
ME 4L							396	479				
ME 4LB												
ME 5S	38	80	M12	41	10	310	418	502	187	187	77	245
ME 5L							462	546				



ME_FD/FA - CE/CUS/BIS

BE-ME

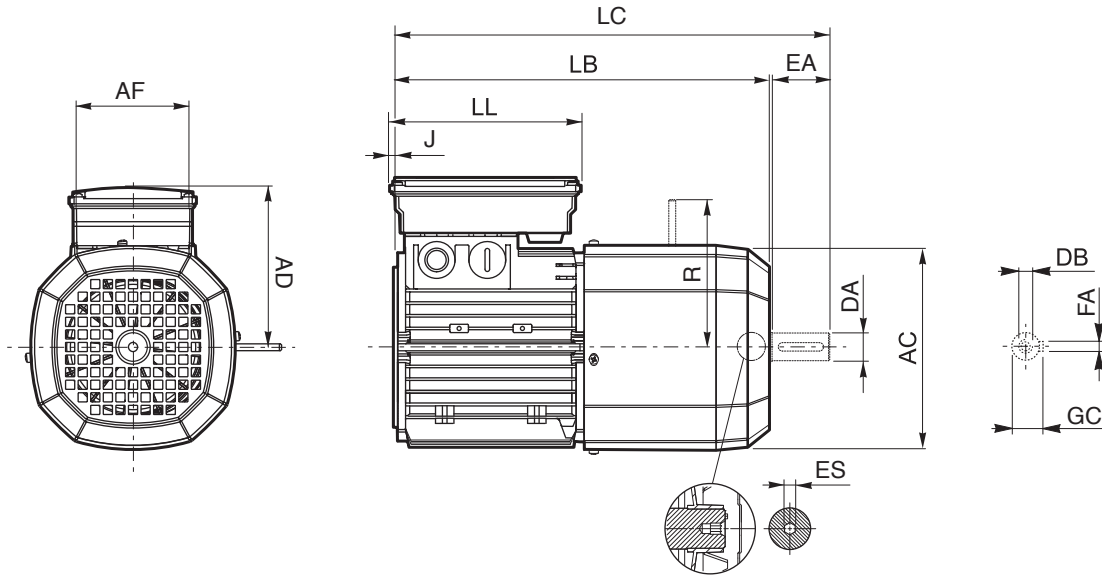



	Zweite Wellenende					Motor										
	DA	EA	DB	GC	FA	AC	LB	LC	AF	LL	J	AD	R FD FA		ES ⁽¹⁾	
ME 05	11	23	M4	12.5	4	121	231	256			-4.5	119	96	116	5	
ME 1S	14	30	M5	16	5	138	248	280	98	133	-8	135	103	124		
ME 2S	19	40	M6	21.5	6	156	272	314			-17	143	129	134		
ME 3S	28	60	M10	31	8	195	326	389	110	165	7	155	160	160	6	
ME 3L							353	416								
ME 4S	38	80	M12	41	10	258	470	553	140	188	7	210	204	200		
ME 4LA							495	578					226	217		
ME 4LB							558	642					266	247		
ME 5S	38	80	M12	41	10	310	602	686	187	187	17	245	266	247		---
ME 5L							558	642								

HINWEIS: (1) Der Sechskant ES ist bei der Option PS nicht vorhanden.





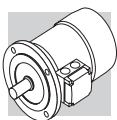

M20 MOTORENAUSWAHLTABELLEN BN-M

2P		3000 min ⁻¹ - S1													50 Hz												
		G.S. Bremse													W.S. Bremse												
		P _n kW		n min ⁻¹	M _n Nm	IE1	η (100%) %	η (75%) %	η (50%) %	cosφ	In 400V A	I _s I _n	M _s M _n	M _a M _n	J _m x 10 ⁻⁴ kgm ²	IM B5 	Mod	M _b Nm	Z ₀ 1/h	NB	SB	J _m x 10 ⁻⁴ kgm ²	IM B5 	Mod	M _b Nm	Z ₀ 1/h	J _m x 10 ⁻⁴ kgm ²
FD	FA																										
0.18	BN 63A	2	2730	0.63	○	59.9	56.9	51.9	0.77	0.56	3.0	2.0	2.0	3.5	FD 02	1.75	3900	4800	—	—	2.6	5.2	FA 02	1.75	4800	2.6	5.0
0.25	BN 63B	2	2740	0.87	○	66.0	64.8	64.8	0.76	0.72	3.3	2.3	2.3	3.9	FD 02	1.75	3900	4800	—	—	3.0	5.6	FA 02	1.75	4800	3.0	5.4
0.37	BN 63C	2	2800	1.26	○	69.1	66.8	66.8	0.78	0.99	3.9	2.6	2.6	5.1	FD 02	3.5	3600	4500	—	—	3.9	6.8	FA 02	3.5	4500	3.9	6.6
0.37	BN 71A	2	2820	1.25	○	73.8	73.0	70.6	0.76	0.95	4.8	2.6	2.6	5.4	FD 03	3.5	3000	4100	—	—	4.6	8.1	FA 03	3.5	4200	4.6	7.8
0.55	BN 71B	2	2820	1.86	○	76.0	75.8	74.8	0.76	1.37	5.0	2.9	2.8	6.2	FD 03	5	2900	4200	—	—	5.3	8.9	FA 03	5	4200	5.3	8.6
0.75	BN 71C	2	2810	2.6	○	76.6	76.2	76.2	0.76	1.86	5.1	3.1	2.8	7.3	FD 03	5	1900	3300	—	—	6.1	10.0	FA 03	5	3600	6.1	9.7
0.75	BN 80A	2	2810	2.6	●	76.2	75.5	68.3	0.81	1.75	4.8	2.6	2.2	8.6	FD 04	5	1700	3200	—	—	9.4	12.5	FA 04	5	3200	9.4	12.4
1.1	BN 80B	2	2800	3.8	●	76.4	76.2	75.0	0.81	2.57	4.8	2.8	2.4	9.5	FD 04	10	1500	3000	—	—	10.6	13.4	FA 04	10	3000	10.6	13.3
1.5	BN 80C	2	2800	5.1	●	79.1	79.5	77.2	0.81	3.4	4.9	2.7	2.4	11.3	FD 04	15	1300	2600	—	—	13.0	15.2	FA 04	15	2600	13.0	15.1
1.5	BN 90SA	2	2870	5.0	●	82.0	81.5	78.1	0.80	3.4	5.9	2.7	2.6	12.3	FD 14	15	900	2200	—	—	14.1	16.5	FA 14	15	2200	14.1	16.4
1.85	BN 90SB	2	2880	6.1	●	82.5	82.0	75.4	0.80	4.0	6.2	2.9	2.6	16.7	FD 14	15	900	2200	—	—	18.3	18.2	FA 14	15	2200	18.3	18.1
2.2	BN 90L	2	2880	7.3	●	82.7	82.1	80.8	0.80	4.8	6.3	2.9	2.7	16.7	FD 05	26	900	2200	—	—	21	20	FA 05	26	2200	21	20.7
3	BN 100L	2	2860	10.0	●	81.5	81.3	77.4	0.79	6.7	5.6	2.6	2.2	31	FD 15	26	700	1600	—	—	35	26	FA 15	26	1600	35	27
4	BN 100LB	2	2870	13.3	●	83.1	83.0	77.8	0.80	8.7	5.8	2.7	2.5	39	FD 15	40	450	900	—	—	43	29	FA 15	40	1000	43	30
4	BN 112M	2	2900	13.2	●	85.5	84.5	83.0	0.82	8.2	6.9	3.0	2.9	57	FD 06S	40	—	950	—	—	66	39	FA 06S	40	950	66	40
5.5	BN 132SA	2	2890	18.2	●	84.7	84.5	81.2	0.84	11.2	5.9	2.6	2.2	101	FD 06	50	—	600	—	—	112	48	FA 06	50	600	112	49
7.5	BN 132SB	2	2900	25	●	86.5	86.3	84.4	0.85	14.7	6.4	2.6	2.2	145	FD 06	50	—	550	—	—	154	55	FA 06	50	550	154	56
9.2	BN 132M	2	2930	30	●	87.0	86.5	83.6	0.86	17.7	6.7	2.8	2.3	178	FD 06	75	—	430	—	—	189	66	FA 06	75	430	189	67
11	BN 160MR	2	2920	36	●	87.6	87.0	86.0	0.88	20.6	6.9	2.9	2.5	210	FD 06	50	—	600	—	—	112	48	FA 06	50	600	112	49
15	BN 160MB	2	2930	49	●	89.6	89.4	88.0	0.86	28.1	7.1	2.6	2.3	340	FD 06	50	—	550	—	—	154	55	FA 06	50	550	154	56
18.5	BN 160L	2	2930	60	●	90.4	90.1	89.0	0.86	34	7.6	2.7	2.3	420	FD 06	75	—	430	—	—	189	66	FA 06	75	430	189	67
22	BN 180M	2	2930	72	●	89.9	89.7	89.5	0.88	40	7.8	2.6	2.4	490	FD 06	75	—	430	—	—	189	66	FA 06	75	430	189	67
30	BN 200LA	2	2930	98	●	90.7	90.1	87.6	0.89	54	7.8	2.7	2.9	770	FD 06	75	—	430	—	—	189	66	FA 06	75	430	189	67

○ = n.a. ● = IE1



4P		1500 min ⁻¹ - S1													50 Hz													
P _n kW		n min ⁻¹	M _n Nm	IE1	η (100%) %	η (75%) %	η (50%) %	cosφ	In 400V A	Is In %	Ms Mn %	Ma Mn %	J _m x 10 ⁻⁴ kgm ²	IM B5  Kg	G.S. Bremse					W.S. Bremse								
															FD		FA					FD		FA				
															Mod	Mb Nm	Z ₀ 1/h	NB	SB	J _m x 10 ⁻⁴ kgm ²	IM B5  Kg	Mod	Mb Nm	Z ₀ 1/h	J _m x 10 ⁻⁴ kgm ²	IM B5  Kg		
0.06	BN 56A	4	1340	0.43	○	46.8	44.2	41.3	0.65	0.28	2.6	2.0	1.5	3.1	FD 02	1.75	10000	13000	2.6	5.2	FA 02	1.75	13000	2.6	5.0			
0.09	BN 56B	4	1350	0.64	○	51.7	47.6	42.9	0.60	0.42	2.6	2.4	1.5	3.1	FD 02	3.5	10000	13000	3.0	5.6	FA 02	3.5	13000	3.0	5.4			
0.12	BN 63A	4	1350	0.85	○	59.8	56.2	47.0	0.62	0.47	2.6	1.9	2.0	3.5	FD 02	3.5	7800	10000	3.9	6.8	FA 02	3.5	10000	3.9	6.6			
0.18	BN 63B	4	1320	1.30	○	54.8	52.9	52.5	0.67	0.71	2.6	2.0	2.3	3.9	FD 03	5	6000	9400	8.0	8.6	FA 03	5	9400	8.0	8.3			
0.25	BN 63C	4	1340	1.78	○	65.3	65.0	57.9	0.69	0.80	2.7	2.1	3.3	5.1	FD 53	7.5	4300	8700	10.2	10.0	FA 03	7.5	8700	10.2	9.7			
0.25	BN 71A	4	1380	1.73	○	63.7	62.2	59.1	0.73	0.78	3.3	1.9	5.8	5.1	FD 03	3.5	7700	11000	6.9	7.8	FA 03	3.5	11000	6.9	7.5			
0.37	BN 71B	4	1370	2.6	○	66.8	66.7	63.0	0.76	1.05	3.7	2.0	6.9	5.9	FD 03	5	6000	9400	8.0	8.6	FA 03	5	9400	8.0	8.3			
0.55	BN 71C	4	1380	3.8	○	69.0	68.9	68.8	0.74	1.55	4.1	2.3	9.1	7.3	FD 53	7.5	4300	8700	10.2	10.0	FA 03	7.5	8700	10.2	9.7			
0.55	BN 80A	4	1390	3.8	○	72.0	71.3	69.7	0.77	1.43	4.1	2.3	2.0	8.2	FD 04	10	4100	8000	16.6	12.1	FA 04	10	8000	16.6	12.0			
0.75	BN 80B	4	1400	5.1	●	75.0	74.5	69.3	0.78	1.85	4.9	2.7	2.5	9.9	FD 04	15	4100	7800	22	13.8	FA 04	15	7800	22	13.7			
1.1	BN 80C	4	1400	7.5	●	75.5	76.2	70.4	0.78	2.7	5.1	2.8	2.5	11.3	FD 04	15	2600	5300	27	15.2	FA 04	15	5300	27	15.1			
1.1	BN 90S	4	1390	7.6	●	76.5	76.2	72.2	0.77	2.70	4.6	2.6	2.2	12.2	FD 14	15	4800	8000	23	16.4	FA 14	15	8000	23	16.3			
1.5	BN 90LA	4	1410	10.2	●	78.7	78.5	74.9	0.77	3.6	5.3	2.8	2.4	28	FD 05	26	3400	6000	32	19.6	FA 05	26	6000	32	20.3			
1.85	BN 90LB	4	1390	12.7	●	78.6	78.9	77.2	0.79	4.3	5.1	2.8	2.6	30	FD 05	26	3200	5900	34	21.1	FA 05	26	5900	34	21.8			
2.2	BN 100LA	4	1410	14.9	●	81.1	81.4	79.9	0.75	5.2	4.5	2.2	2.0	40	FD 15	40	2600	4700	44	25	FA 15	40	4700	44	25			
3	BN 100LB	4	1410	20	●	82.6	83.8	83.7	0.77	6.8	5.0	2.3	2.2	54	FD 15	40	2400	4400	58	28	FA 15	40	4400	58	29			
4	BN 112M	4	1430	27	●	84.4	84.2	81.6	0.81	8.4	5.6	2.7	2.5	98	FD 06S	60	—	1400	107	40	FA 06S	60	2100	107	42			
5.5	BN 132S	4	1440	36	●	84.7	84.8	82.5	0.81	11.6	5.5	2.3	2.2	213	FD 56	75	—	1050	223	57	FA 06	75	1200	223	58			
7.5	BN 132MA	4	1440	50	●	86.0	86.3	85.3	0.81	15.5	5.7	2.5	2.4	270	FD 06	100	—	950	280	66	FA 07	100	1000	280	71			
9.2	BN 132MB	4	1440	61	●	88.4	88.6	87.5	0.81	18.8	5.9	2.7	2.5	319	FD 07	150	—	900	342	75	FA 07	150	900	342	77			
11	BN 160MR	4	1440	73	●	87.6	87.8	86.0	0.81	22.4	6.0	2.7	2.5	360	FD 07	150	—	850	382	86	FA 07	150	850	382	88			
15	BN 160L	4	1460	98	●	88.7	88.5	88.4	0.81	30	6.0	2.3	2.1	650	FD 08	200	—	750	725	129	FA 08	200	750	710	128			
18.5	BN 180M	4	1460	121	●	89.3	89.5	89.2	0.81	37	6.2	2.6	2.5	790	FD 08	250	—	700	865	145	FA 08	250	700	850	144			
22	BN 180L	4	1460	144	●	89.9	90.0	90.0	0.80	44	6.4	2.5	2.5	1250	FD 09	300	—	400	1450	175	FA 08	250	700	850	144			
30	BN 200L	4	1460	196	●	91.4	91.7	91.0	0.80	59	7.1	2.7	2.8	1650	FD 09	400	—	300	1850	197	FA 08	250	700	850	144			

○ = n.a. ● = IE1

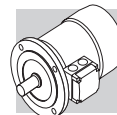



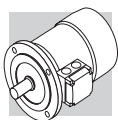

6P **1000 min⁻¹ - S1** **50 Hz**

P _n kW		n min ⁻¹	M _n Nm	IE1	η (100%) %	η (75%) %	η (50%) %	cosφ	In 400V A	Is In A	Ms Mn	Ma Mn	J _m x 10 ⁻⁴ kgm ²	IM B5 Kg	G.S. Bremse					W.S. Bremse									
															FD		FD		FA		FA		IM B5 Kg	J _m x 10 ⁻⁴ kgm ²	Mb Nm	Mod	Z ₀ 1/h	J _m x 10 ⁻⁴ kgm ²	IM B5 Kg
															Mod	Mb	Z ₀ 1/h	NB	SB	Mod	Mb	Z ₀ 1/h							
0.09	BN 63A	6	0.98	○	41.0	41.0	32.9	0.53	0.60	2.1	2.1	1.8	3.4	4.6	FD 02	3.5	9000	14000	14000	FA 02	3.5	14000	4.0	6.3					
0.12	BN 63B	6	1.32	○	45.0	44.0	41.8	0.60	0.64	2.1	1.9	1.7	3.7	4.9	FD 02	3.5	9000	14000	14000	FA 02	3.5	14000	4.3	6.6					
0.18	BN 71A	6	1.91	○	55.0	55.5	51.0	0.69	0.68	2.6	1.9	1.7	8.4	5.5	FD 03	5	8100	13500	13500	FA 03	5.0	13500	9.5	8.2					
0.25	BN 71B	6	2.70	○	62.0	58.5	51.4	0.71	0.82	2.6	1.9	1.7	10.9	6.7	FD 03	5	7800	13000	13000	FA 03	5.0	13000	12	9.4					
0.37	BN 71C	6	3.9	○	66.0	60.0	53.3	0.69	1.17	3.0	2.4	2.0	12.9	7.7	FD 53	7.5	5100	9500	9500	FA 03	7.5	9500	14	10.4					
0.37	BN 80A	6	3.9	○	68.0	67.4	63.3	0.68	1.15	3.2	2.2	2.0	21	9.9	FD 04	10	5200	8500	8500	FA 04	10	8500	23	13.8					
0.55	BN 80B	6	5.7	○	70.0	69.8	64.3	0.68	1.67	3.9	2.6	2.2	25	11.3	FD 04	15	4800	7200	7200	FA 04	15	7200	27	15.2					
0.75	BN 80C	6	7.8	●	70.0	70.0	64.4	0.65	2.38	3.8	2.5	2.2	28	12.2	FD 04	15	3400	6400	6400	FA 04	15	6400	30	16.1					
0.75	BN 90S	6	7.8	●	70.0	69.0	64.2	0.68	2.27	3.8	2.4	2.2	26	12.6	FD 14	15	3400	6500	6500	FA 14	15	6500	28	16.8					
1.1	BN 90L	6	11.4	●	72.9	72.6	69.1	0.69	3.2	3.9	2.3	2.0	33	15	FD 05	26	2700	5000	5000	FA 05	26	5000	37	21					
1.5	BN 100LA	6	15.2	●	75.2	74.2	70.3	0.72	4.0	4.1	2.1	2.0	82	22	FD 15	40	1900	4100	4100	FA 15	40	4100	86	28					
1.85	BN 100LB	6	19.0	●	76.6	72.8	62.6	0.73	4.8	4.6	2.1	2.0	95	24	FD 15	40	1700	3600	3600	FA 15	40	3600	99	30					
2.2	BN 112M	6	22	●	78.5	79.0	76.5	0.73	5.5	4.8	2.2	2.0	168	32	FD 06S	60	—	2100	2100	FA 06S	60	2100	177	42					
3	BN 132S	6	30	●	79.7	77.0	75.1	0.76	7.1	5.1	1.9	1.8	216	36	FD 56	75	—	1400	1400	FA 06	75	1400	226	49					
4	BN 132MA	6	40	●	81.4	81.5	79.5	0.77	9.2	5.5	2.0	1.8	295	45	FD 06	100	—	1200	1200	FA 07	100	1200	305	58					
5.5	BN 132MB	6	56	●	83.1	80.9	79.1	0.78	12.2	6.1	2.1	1.9	383	56	FD 07	150	—	1050	1050	FA 07	150	1050	406	72					
7.5	BN 160M	6	75	●	85.0	85.0	84.8	0.81	15.7	5.9	2.2	2.0	740	83	FD 08	170	—	900	900	FA 08	170	900	815	112					
11	BN 160L	6	109	●	86.4	86.5	85.9	0.81	22.7	6.6	2.5	2.3	970	103	FD 08	200	—	800	800	FA 08	200	800	1045	133					
15	BN 180L	6	148	●	87.7	88.0	87.3	0.82	30	6.2	2.0	2.4	1550	130	FD 09	300	—	600	600	FA 08	200	800	1750	170					
18.5	BN 200LA	6	184	●	88.6	88.0	87.3	0.81	37	5.9	2.0	2.3	1700	145	FD 09	400	—	450	450	FA 08	200	800	1900	185					

○ = n.a. ● = IE1





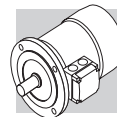

8P		750 min ⁻¹ - S1													50 Hz								
		G.S. Bremse													W.S. Bremse								
P _n kW		n min ⁻¹	M _n Nm	η %	cosφ	I _n 400V A	I _s I _n	M _s M _n	M _a M _n	J _m x 10 ⁻⁴ kgm ²	IM B5 	Mod	Mb Nm	Z _o 1/h	NB	SB	J _m x 10 ⁻⁴ kgm ²	IM B5 	Mod	Mb Nm	Z _o 1/h	J _m x 10 ⁻⁴ kgm ²	IM B5 
0.09	BN 71A	8	1.26	47	0.59	0.47	2.3	2.4	2.3	10.9	6.7	FD 03	3.5	9000	16000	16000	12.0	9.4	FA 03	3.5	16000	12.0	9.1
0.12	BN 71B	8	1.69	51	0.59	0.58	2.1	2.3	2.2	12.9	7.7	FD 03	5.0	9000	16000	16000	14.0	10.4	FA 03	5.0	16000	14.0	10.1
0.18	BN 80A	8	2.49	51	0.60	0.85	2.4	2.2	2.2	15	8.2	FD 04	5.0	6500	11000	11000	16.6	12.1	FA 04	5.0	11000	16.6	12.0
0.25	BN 80B	8	3.51	54	0.63	1.06	2.4	2.0	1.9	20	9.9	FD 04	10.0	6000	10000	10000	22	13.8	FA 04	10.0	10000	23	13.7
0.37	BN 90S	8	5.2	58	0.60	1.53	2.6	2.3	2.1	26	12.6	FD 14	15.0	4800	7500	7500	28	16.8	FA 14	15.0	7500	28	16.7
0.55	BN 90L	8	7.8	62	0.60	2.13	2.6	2.2	2.0	33	15	FD 05	26	4000	6400	6400	37	21	FA 05	26	6400	37	22
0.75	BN 100LA	8	10.2	68	0.63	2.53	3.4	1.9	1.7	82	22	FD 15	26	2800	4800	4800	86	28	FA 15	26	4800	86	29
1.1	BN 100LB	8	15.0	68	0.64	3.65	3.2	1.7	1.7	95	24	FD 15	40	2500	4000	4000	99	30	FA 15	40	4000	99	31
1.5	BN 112M	8	20.2	71	0.66	4.6	3.7	1.8	1.9	168	32	FD 06S	60	—	3000	3000	177	42	FA 06S	60	3000	177	44
2.2	BN 132S	8	29.6	75	0.66	6.4	3.8	1.8	2.0	295	45	FD 56	75	—	2300	2300	305	58	FA 06	75	2300	305	56
3	BN 132MA	8	40.4	76	0.69	8.3	3.9	1.6	1.8	370	53	FD 06	100	—	1900	1900	394	69	FA 07	100	1900	406	74

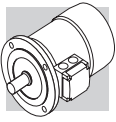

2/4P **3000/1500 min⁻¹ - S1** **50 Hz**

P _n kW		G.S. Bremse														W.S. Bremse											
		FD														FA											
		IM B5	J _m x 10 ⁻⁴ kgm ²	M _a M _n	M _s M _n	I _s I _n	I _n 400V A	cos φ	η	M _n	n	M _b	Mod	IM B5	J _m x 10 ⁻⁴ kgm ²	M _b	Mod	IM B5	J _m x 10 ⁻⁴ kgm ²	Z ₀ 1/h	M _b	Mod	IM B5	J _m x 10 ⁻⁴ kgm ²	Z ₀ 1/h	M _b	Mod
0.20	0.15	BN 63B	2	2700	0.71	55	0.82	0.64	3.5	2.1	1.9	2.9	4.4	FD 02	3.5	2200	2600	5100	6.1	3.5	2600	5100	FA 02	3.5	2600	5100	5.9
0.28	0.20	BN 71A	2	2700	0.99	56	0.82	0.88	2.9	1.9	1.7	4.7	4.4	FD 03	3.5	2100	2400	4800	7.1	5.8	2400	4800	FA 03	3.5	2400	4800	6.8
0.37	0.25	BN 71B	2	2740	1.29	56	0.82	1.16	3.5	1.8	1.8	5.8	5.1	FD 03	5.0	1400	2100	4200	7.8	6.9	2100	4200	FA 03	5.0	2100	4200	7.5
0.45	0.30	BN 71C	2	2780	1.55	63	0.85	1.21	3.8	1.8	1.8	6.9	5.9	FD 03	5.0	1400	2100	4200	8.6	8.0	2100	4200	FA 03	5.0	2100	4200	8.3
0.55	0.37	BN 80A	2	2800	1.9	63	0.85	1.48	3.9	1.7	1.7	15	8.2	FD 04	5.0	1600	2300	4000	12.1	17	2300	4000	FA 04	5.0	2300	4000	12.0
0.75	0.55	BN 80B	2	2780	2.6	65	0.85	1.96	3.8	1.9	1.8	20	9.9	FD 04	10	1400	1600	3600	13.8	22	1600	3600	FA 04	10	1600	3600	13.7
1.1	0.75	BN 90S	2	2790	3.8	71	0.82	2.73	4.7	2.3	2.0	21	12.2	FD 14	10	1500	1600	2800	16.4	23	1600	2800	FA 14	10	1600	2800	16.3
1.5	1.1	BN 90L	2	2780	5.2	70	0.85	3.64	4.5	2.4	2.1	28	14.0	FD 05	26	1050	1200	2000	20	32	1200	2000	FA 05	26	1200	2000	21
2.2	1.5	BN 100LA	2	2800	7.5	72	0.85	5.2	4.5	2.0	1.9	40	18.3	FD 15	26	600	900	2300	25	44	900	2300	FA 15	26	900	2300	25
3.5	2.5	BN 100LB	2	2850	11.7	80	0.84	7.5	5.4	2.2	2.1	61	25	FD 15	40	500	900	2100	31	65	900	2100	FA 15	40	900	2100	32
4	3.3	BN 112M	2	2880	13.3	79	0.83	8.8	6.1	2.4	2.0	98	30	FD 06S	60	—	700	1200	40	107	700	1200	FA 06S	60	700	1200	42
5.5	4.4	BN 132S	2	2890	18.2	80	0.87	11.4	5.9	2.4	2.0	213	44	FD 56	75	—	350	900	57	223	350	900	FA 06	75	350	900	58
7.5	6	BN 132MA	2	2900	25	82	0.87	15.2	6.5	2.4	2.0	270	53	FD 06	100	—	350	900	66	280	350	900	FA 07	100	350	900	71
9.2	7.3	BN 132MB	2	2920	30	83	0.86	18.6	6.0	2.6	2.2	319	59	FD 07	150	—	300	800	75	342	300	800	FA 07	150	300	800	77



2/6P		3000/1000 min ⁻¹ - S3 60/40%														50 HZ									
		G.S. Bremse														W.S. Bremse									
		FD							FA							FA		FA							
P _n		n	M _n	η	cosφ	I _n	I _n	I _s	M _s	M _a	J _m	IM B5	MMod	Mb	Z ₀	1/h	SB	J _m	IM B5	MMod	Mb	Z ₀	1/h	J _m	IM B5
kW		min ⁻¹	Nm	%		A	A	$\frac{in}{in}$	$\frac{Ms}{Mn}$	$\frac{Ma}{Mn}$	x 10 ⁻⁴ kgm ²			Nm	1/h			x 10 ⁻⁴ kgm ²			Nm	1/h		x 10 ⁻⁴ kgm ²	
0.25	BN 71A	2	0.84	60	0.82	0.73	4.3	1.9	1.8	6.9	5.9	FD 03	1.75	1500	1700	13000	8.0	8.0	FA 03	2.5	1700	13000	8.0	8.0	8.3
0.08		6	0.84	43	0.70	0.38	2.1	1.4	1.5					10000											
0.37	BN 71B	2	1.23	62	0.80	1.08	4.4	1.9	1.8	9.1	7.3	FD 03	3.5	1000	1300	11000	10.2	10.2	FA 03	3.5	1300	11000	10.2	10.2	9.7
0.12		6	1.27	44	0.73	0.54	2.4	1.4	1.5					9000											
0.55	BN 80A	2	1.88	63	0.86	1.47	4.5	1.9	1.7	20	9.9	FD 04	5.0	1500	1800	6300	22	22	FA 04	5.0	1800	6300	22	22	13.7
0.18		6	1.85	52	0.65	0.77	3.3	2.0	1.9					4100											
0.75	BN 80B	2	2.6	66	0.87	1.89	4.3	1.8	1.6	25	11.3	FD 04	5.0	1700	1900	6000	27	27	FA 04	5.0	1900	6000	27	27	15.1
0.25		6	2.6	54	0.67	1.00	3.2	1.7	1.8					3800											
1.10	BN 90L	2	3.7	67	0.84	2.82	4.7	2.1	1.9	28	14.0	FD 05	13	1400	1600	5200	32	32	FA 05	13	1600	5200	32	32	21
0.37		6	3.8	59	0.71	1.27	3.3	1.6	1.6					3400											
1.5	BN 100LA	2	5	73	0.84	3.53	5.1	1.9	2.0	40	18.3	FD 15	13	1000	1200	4000	44	44	FA 15	13	1200	4000	44	44	25
0.55		6	5.6	64	0.67	1.85	3.5	1.7	1.8					2900											
2.2	BN 100LB	2	7.2	77	0.85	4.9	5.9	2.0	2.0	61	25	FD 15	26	700	900	3000	65	65	FA 15	26	900	3000	65	65	32
0.75		6	7.5	67	0.64	2.5	3.3	1.9	1.8					2100											
3	BN 112M	2	9.9	78	0.87	6.4	6.3	2.0	2.1	98	30	FD 06S	40	—	1000	107	107	107	40	FA 06S	40	1000	107	107	32
1.1		6	11.1	72	0.64	3.4	3.9	1.8	1.8					—	2600										
4.5	BN 132S	2	14.8	78	0.84	9.9	5.8	1.9	1.8	213	44	FD 66	37	—	500	223	223	223	57	FA 06	37	500	223	223	58
1.5		6	14.9	74	0.67	4.4	4.2	1.9	2.0					—	2100										
5.5	BN 132M	2	18.0	78	0.87	11.7	6.2	2.1	1.9	270	53	FD 66	50	—	400	280	280	280	66	FA 06	50	400	280	280	67
2.2		6	22	77	0.71	5.8	4.3	2.1	2.0					—	1900										

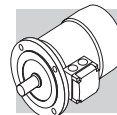

2/8P **3000/750 min-1 - S3 60/40%** **50 HZ**

P _n kW		G.S. Bremse															W.S. Bremse									
		FD										FA					FA									
		IM B5 Kg	J _m x 10 ⁻⁴ kgm ²	Ma Mn	Ms Mn	Is in	In 400V A	cosφ	η	M _n Nm	n min ⁻¹	IM B5 Kg	J _m x 10 ⁻⁴ kgm ²	Z ₀ 1/h	Mod	Mb Nm	Z ₀ 1/h	J _m x 10 ⁻⁴ kgm ²	IM B5 Kg							
0.25	0.06	BN 71A	2	2790	0.86	61	0.87	3.9	1.8	1.9	10.9	6.7	FD 03	1.75	1300	1400	1400	13000	12	9.4	FA 03	2.5	1400	13000	12	9.1
0.37	0.09	BN 71B	8	680	0.84	31	0.61	2.0	1.8	1.9	12.9	7.7	FD 03	3.5	10000	13000	13000	13000	14	10.4	FA 03	3.5	1300	13000	14	10.1
0.55	0.13	BN 80A	2	2830	1.86	66	0.86	4.4	2.1	2.0	20	9.9	FD 04	5.0	1500	1800	1800	1800	22	13.8	FA 04	5.0	1800	8000	22	13.7
0.75	0.18	BN 80B	8	690	1.80	41	0.64	2.3	1.6	1.7	25	11.3	FD 04	10	5600	8000	8000	8000	27	15.2	FA 04	10	1900	7300	27	15.1
1.10	0.28	BN 90L	2	2830	3.7	63	0.84	4.5	2.1	1.9	28	14.0	FD 05	13	1400	1600	1600	1600	32	20	FA 05	13	1600	5100	32	21
1.5	0.37	BN 100LA	2	2880	5.0	69	0.85	4.7	1.9	1.8	40	18.3	FD 15	13	1000	1200	1200	5000	44	25	FA 15	13	1200	5000	44	25
2.4	0.55	BN 100LB	8	690	5.1	46	0.63	1.84	1.6	1.6	61	25	FD 15	26	3300	5000	5000	2000	65	31	FA 15	26	700	3500	65	32
3	0.75	BN 112M	2	2900	9.9	76	0.87	6.3	2.1	1.9	98	30	FD 06S	40	—	900	900	2900	107	40	FA 06S	40	900	2900	107	42
4	1	BN 132S	2	2870	13.3	73	0.84	5.6	2.3	2.4	213	44	FD 66	37	—	500	500	3500	223	57	FA 06	37	500	3500	223	58
5.5	1.5	BN 132M	8	690	13.8	66	0.62	3.5	1.9	1.8	270	53	FD 06	50	—	400	400	2400	280	66	FA 06	50	400	2400	280	67

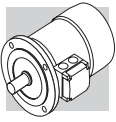



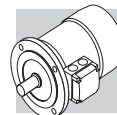

2/12P		3000/500 min ⁻¹ - S3 60/40%														50 Hz											
		G.S. Bremse														W.S. Bremse											
		FD							FA							FA		FA									
P _n	kW	P _n	n	M _n	η	cos φ	I _n	I _n	I _s	M _s	M _a	J _m	IM B5	Mod	Mb	Z ₀	1/h	SB	NB	J _m	IM B5	Mod	Mb	Z ₀	1/h	J _m	IM B5
400V																											
0.55		2	2820	1.86	64	0.89	1.39	4.2	1.6	1.7	25	11.3	FD 04	5.0	1000	1300	12000	8000	1000	27	15.2	FA 04	5.0	1300	12000	27	15.1
0.09		12	430	2.0	30	0.63	0.69	1.8	1.9	1.8																	
0.75		2	2790	2.6	56	0.89	2.17	4.2	1.8	1.7	26	12.6	FD 05	13	1000	1150	6300	4600	1000	30	18.6	FA 05	13	1150	6300	30	19.3
0.12		12	430	2.7	26	0.63	1.06	1.7	1.4	1.6																	
1.10		2	2850	3.7	65	0.85	2.87	4.5	1.6	1.8	40	18.3	FD 15	13	700	900	6000	4000	700	44	25	FA 15	13	900	6000	44	25
0.18		12	430	4.0	26	0.54	1.85	1.5	1.3	1.5																	
1.5		2	2900	4.9	67	0.86	3.76	5.6	1.9	1.9	54	22	FD 15	13	700	900	5000	3800	700	58	28	FA 15	13	900	5000	58	29
0.25		12	440	5.4	36	0.46	2.18	1.8	1.7	1.8																	
2		2	2900	6.6	74	0.88	4.43	6.5	2.1	2.0	98	30	FD 06S	20	—	800	3400	—	800	107	40	FA 06S	20	800	3400	107	42
0.3		12	460	6.2	46	0.43	2.19	2.0	2.1	2.0																	
3		2	2920	9.8	74	0.87	6.7	6.8	2.3	1.9	213	44	FD 56	37	—	450	3000	—	450	223	57	FA 06	37	450	3000	223	58
0.5		12	470	10.2	51	0.43	3.3	2.0	1.7	1.6																	
4		2	2920	13.1	75	0.89	8.6	5.9	2.4	2.3	270	53	FD 56	37	—	400	2800	—	400	280	66	FA 06	37	400	2800	280	67
0.7		12	460	14.5	53	0.44	4.3	1.9	1.7	1.6																	

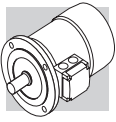

4/6P **1500/1000 min⁻¹ - S1** **50 HZ**





P _n kW		G.S. Bremse														W.S. Bremse													
		FD														FA													
		IM B5	J _m x 10 ⁻⁴ kgm ²	Ma Mn	Ms Mn	Is In	cos φ	η	M _n	n	IM B5	J _m x 10 ⁻⁴ kgm ²	Z ₀ 1/h	NB	SB	Mod	Mb	IM B5	J _m x 10 ⁻⁴ kgm ²	Z ₀ 1/h	Nm	Mod	Mb	IM B5	J _m x 10 ⁻⁴ kgm ²				
0.22	0.13	4	1410	1.5	64	0.74	3.9	1.8	1.9	7.3	7.3	3.5	2500	3500	10.2	10.2	3500	3500	10.2	10.2	3500	3500	10.2	10.2	3500	3500	10.2	10.2	9.7
		6	920	1.4	43	0.67	2.3	1.6	1.7			5.0	5000	9000			9000	9000			9000	9000			9000	9000			
0.30	0.20	4	1410	2.0	61	0.82	3.5	1.3	1.5	8.2	8.2	5.0	2500	3100	16.6	16.6	3100	3100	16.6	16.6	3100	3100	5.0	5.0	3100	3100	16.6	12.0	
		6	930	2.1	54	0.66	3.2	1.9	2.0			5.0	4000	6000			6000	6000			6000	6000			6000	6000			
0.40	0.26	4	1430	2.7	63	0.75	3.9	1.8	1.8	9.9	9.9	10	1800	2300	22	22	2300	2300	22	22	2300	2300	10	10	2300	2300	22	13.7	
		6	930	2.7	55	0.70	2.7	1.5	1.6			10	3600	5500			5500	5500			5500	5500			5500	5500			
0.55	0.33	4	1420	3.7	70	0.78	4.5	2.0	1.9	12.2	12.2	10	1500	2100	23	23	2100	2100	23	23	2100	2100	10	10	2100	2100	23	16.3	
		6	930	3.4	62	0.70	3.7	2.3	2.0			10	2500	4100			4100	4100			4100	4100			4100	4100			
0.75	0.45	4	1420	5.0	74	0.78	4.3	1.9	1.8	14	14	13	1400	2000	32	32	2000	2000	32	32	2000	2000	13	13	2000	2000	32	21	
		6	920	4.7	66	0.71	3.3	2.0	1.9			13	2300	3600			3600	3600			3600	3600			3600	3600			
1.1	0.8	4	1450	7.2	74	0.79	5.0	1.7	1.9	22	22	26	1400	2000	86	86	2000	2000	86	86	2000	2000	26	26	2000	2000	86	29	
		6	950	8.0	65	0.69	4.1	1.9	2.1			26	2100	3300			3300	3300			3300	3300			3300	3300			
1.5	1.1	4	1450	9.9	75	0.79	5.1	1.7	1.9	25	25	26	1300	1800	99	99	1800	1800	99	99	1800	1800	26	26	1800	1800	99	32	
		6	950	11.1	72	0.68	4.3	2.0	2.1			26	2000	3000			3000	3000			3000	3000			3000	3000			
2.3	1.5	4	1450	15.2	75	0.78	5.2	1.8	1.9	32	32	40	—	1600	177	177	1600	1600	177	177	1600	1600	40	40	1600	1600	177	44	
		6	960	14.9	73	0.72	4.1	2.0	2.0			40	—	2400			2400	2400			2400	2400			2400	2400			
3.1	2	4	1460	20	83	0.83	5.9	2.1	2.0	44	44	37	—	1200	223	223	1200	1200	223	223	1200	1200	37	37	1200	1200	223	58	
		6	960	20	77	0.75	4.9	2.1	2.1			37	—	1900			1900	1900			1900	1900			1900	1900			
4.2	2.6	4	1460	27	84	0.82	8.8	2.1	2.2	53	53	50	—	900	280	280	900	900	280	280	900	900	50	50	900	900	280	67	
		6	960	26	79	0.72	6.6	2.0	2.0			50	—	1500			1500	1500			1500	1500			1500	1500			

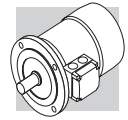

4/8P		1500/750 min ⁻¹ - S1														50 HZ					
		G.S. Bremse														W.S. Bremse					
		FD							FA							FA					
P _n		n	M _n	η	cosφ	I _n	I _s	M _s	M _a	J _m	IM B5	Mod	Mb	Z ₀	J _m	IM B5	Mod	Mb	Z ₀	J _m	IM B5
kW		min ⁻¹	Nm	%		A	$\frac{I_s}{I_n}$	$\frac{M_s}{M_n}$	$\frac{M_a}{M_n}$	$\times 10^{-4}$ kgm ²			Nm	1/h	$\times 10^{-4}$ kgm ²			Nm	1/h	$\times 10^{-4}$ kgm ²	
0.37	BN 80A	4	2.5	63	0.82	1.03	3.3	1.4	1.4	15	8.2	FD 04	10	2300	16.6	12.1	FA 04	10	3500	16.6	12.0
0.18		8	2.5	44	0.60	0.98	2.2	1.5	1.6					4500	7000				7000		
0.55	BN 80B	4	3.8	65	0.86	1.42	3.8	1.7	1.6	20	9.9	FD 04	10	2200	22	13.8	FA 04	10	2900	22	13.7
0.30		8	4.3	49	0.65	1.36	2.3	1.7	1.8					4200	6500				6500		
0.65	BN 90S	4	4.5	73	0.85	1.51	4.0	1.9	1.9	28	13.6	FD 14	15	2300	30	17.8	FA 14	15	2800	30	17.7
0.35		8	4.8	49	0.57	1.81	2.5	2.1	2.2					3500	6000				6000		
0.9	BN 90L	4	6.3	73	0.87	2.05	3.8	1.8	1.8	30	15.1	FD 05	26	1700	34	21	FA 05	26	2100	34	22
0.5		8	7.1	57	0.62	2.04	2.4	2.1	2.0					2500	4200				4200		
1.30	BN 100LA	4	8.7	72	0.83	3.14	4.3	1.7	1.8	82	22	FD 15	40	1300	86	28	FA 15	40	1700	86	29
0.70		8	9.6	58	0.64	2.72	2.8	1.8	1.8					2000	3400				3400		
1.8	BN 100LB	4	12.1	69	0.87	4.3	4.2	1.6	1.7	95	25	FD 15	40	1200	99	31	FA 15	40	1700	99	32
0.9		8	12.3	62	0.63	3.3	3.2	1.7	1.8					1600	2600				2600		
2.2	BN 112M	4	14.6	77	0.85	4.9	5.3	1.8	1.8	168	32	FD 06S	60	—	177	42	FA 06S	60	1200	177	43
1.2		8	16.1	70	0.63	3.9	3.3	1.9	1.8					—	2000				2000		
3.6	BN 132S	4	24	80	0.82	7.9	6.5	2.1	1.9	295	45	FD 56	75	—	305	58	FA 06	75	1000	305	59
1.8		8	24	72	0.55	6.6	4.6	1.9	2.0					—	1400				1400		
4.6	BN 132M	4	30	81	0.83	9.9	6.5	2.2	1.9	383	56	FD 06	100	—	393	69	FA 07	100	1000	393	74
2.3		8	31	73	0.54	8.4	4.4	2.3	2.0					—	1300				1300		





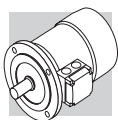

2P **3000 min⁻¹ - S1** **50 Hz**

		G.S. Bremse													W.S. Bremse										
P _n kW		n min ⁻¹	M _n Nm	IE1	η (100%) %	η (75%) %	η (50%) %	cosφ	I _n 400V A	I _s I _n	M _s M _n	M _a M _n	J _m x 10 ⁻⁴ kgm ²	IM B5 	Mod	Mb Nm	Z _c 1/h NB	Z _c 1/h SB	J _m x 10 ⁻⁴ kgm ²	IM B5 	IMod	Mb Nm	Z _c 1/h	J _m x 10 ⁻⁴ kgm ²	IM B5 
0.18	M 05A	2	2730	0.63	○	59.9	56.9	51.9	0.77	0.56	3.0	2.0	2.0	3.2	FD 02	1.75	3900	4800	2.6	4.9	FA 02	1.75	4800	2.6	4.7
0.25	M 05B	2	2740	0.87	○	66.0	64.8	64.8	0.76	0.72	3.3	2.3	2.3	3.6	FD 02	1.75	3900	4800	3.0	5.3	FA 02	1.75	4800	3.0	5.1
0.37	M 05C	2	2800	1.26	○	69.1	66.8	66.8	0.78	0.99	3.9	2.6	2.6	4.8	FD 02	3.5	3600	4500	3.9	6.5	FA 02	3.5	4500	3.9	6.3
0.55	M 15D	2	2820	1.86	○	76.0	75.8	74.8	0.76	1.37	5.0	2.8	2.8	5.8	FD 03	5	2900	4200	5.3	8.5	FA 03	5	4200	5.3	8.2
0.75	M 15A	2	2810	2.6	○	76.6	76.2	76.2	0.76	1.86	5.1	2.8	2.8	6.9	FD 03	5	1900	3300	6.1	9.6	FA 03	5	3300	6.1	9.3
1.1	M 25A	2	2800	3.8	●	76.4	76.2	75.0	0.81	2.57	4.8	2.4	2.4	8.8	FD 04	10	1500	3000	10.6	11.9	FA 04	10	3000	10.6	12.6
1.5	M 25B	2	2800	5.1	●	79.1	79.5	77.2	0.81	3.4	4.9	2.7	2.4	10.6	FD 04	15	1300	2600	13.0	9.9	FA 04	15	2600	13.0	14.4
2.2	M 35A	2	2880	7.3	●	82.7	82.1	81.0	0.80	4.8	6.3	2.9	2.7	15.5	FD 15	26	1100	2400	28	22	FA 15	26	2400	28	23
3	M 35LA	2	2860	10.0	●	81.5	81.3	77.4	0.79	6.7	5.6	2.6	2.2	18.7	FD 15	26	700	1600	35	25	FA 15	26	1600	35	26
4	M 35LB	2	2870	13.3	●	83.1	83.0	77.8	0.80	8.7	5.8	2.7	2.5	22	FD 15	40	450	900	43	28	FA 15	40	900	43	29
5.5	M 45A	2	2890	18.2	●	84.7	84.5	81.2	0.84	11.2	5.9	2.6	2.2	33	FD 06	50	—	600	112	46	FA 06	50	600	112	47
7.5	M 45B	2	2900	25	●	86.5	86.3	84.4	0.85	14.7	6.4	2.6	2.2	40	FD 06	50	—	550	154	53	FA 06	50	550	154	54
9.2	M 45LA	2	2930	30	●	87.0	86.5	83.6	0.86	17.7	6.7	2.8	2.3	51	FD 06	75	—	430	189	64	FA 06	75	430	189	65
11	M 45LC	2	2920	36	●	87.6	87.0	86.0	0.88	20.6	6.9	2.9	2.5	60	FD 06	75	—	—	—	—	—	—	—	—	—
15	M 55B	2	2930	49	●	89.6	89.4	88.0	0.86	28.1	7.1	2.6	2.3	70	FD 06	75	—	—	—	—	—	—	—	—	—
18.5	M 55C	2	2930	60	●	90.4	90.1	89.0	0.86	34	7.6	2.7	2.3	83	FD 06	75	—	—	—	—	—	—	—	—	—
22	M 55LA	2	2930	72	●	89.9	89.7	89.5	0.88	40	7.8	2.6	2.4	95	FD 06	75	—	—	—	—	—	—	—	—	—

○ = n.a. ● = IE1





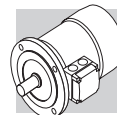

4P		1500 min ⁻¹ - S1														50 Hz										
		G.S. Bremse														W.S. Bremse										
		FD														FA										
P _n		n	M _n	IE1	η (100%)	η (75%)	η (50%)	cosφ	In	I _s /I _n	M _s /M _n	M _a /M _n	J _m x 10 ⁻⁴ kgm ²	IM B5 	Mod	Mb	Z _c 1/h	NB	SB	J _m x 10 ⁻⁴ kgm ²	IM B5 	Mb	Z _c 1/h	J _m x 10 ⁻⁴ kgm ²	IM B5 	
0.09	M 0B 4	1350	0.64	○	51.7	47.6	42.9	0.60	0.42	2.6	2.5	2.4	1.5	2.9	FD 02	1.75	10000	13000	10000	2.6	4.9	1.75	13000	2.6	4.7	
0.12	M 05A 4	1350	0.85	○	59.8	56.2	47.0	0.62	0.47	2.6	1.9	1.8	2.0	3.2	FD 02	3.5	10000	13000	10000	3.0	5.3	3.5	13000	3.0	5.1	
0.18	M 05B 4	1320	1.30	○	54.8	52.9	52.5	0.67	0.71	2.6	2.2	2.0	2.3	3.6	FD 02	3.5	7800	10000	7800	3.9	6.5	3.5	10000	3.9	6.3	
0.25	M 05C 4	1340	1.78	○	65.3	65.0	57.9	0.69	0.80	2.7	2.1	1.9	3.3	4.8	FD 02	5	6000	9400	6000	8.0	8.2	5	9400	8.0	7.9	
0.37	M 15D 4	1370	2.6	○	66.8	66.7	63.0	0.76	1.05	3.7	2.0	1.9	6.9	5.5	FD 03	7.5	4300	8700	4300	10.2	9.6	7.5	8700	10.2	9.3	
0.55	M 1LA 4	1380	3.8	○	69.0	68.9	68.8	0.74	1.55	4.1	2.3	2.3	9.1	6.9	FD 53	15	4100	7800	4100	22	13.1	15	7800	22	13.0	
0.75	M 25A 4	1400	5.1	●	75.0	74.5	69.3	0.78	1.85	4.9	2.7	2.5	20	9.2	FD 04	15	2600	5300	2600	27	14.5	15	5300	27	14.4	
1.1	M 25B 4	1400	7.5	●	76.4	76.2	70.4	0.78	2.66	5.1	2.8	2.5	25	10.6	FD 04	26	2800	4900	2800	38	22	26	4900	38	23	
1.5	M 35A 4	1410	10.2	●	79.6	80.5	79.3	0.77	3.5	4.6	2.1	2.1	34	15.5	FD 15	40	2600	4700	2600	44	24	40	4700	44	24	
2.2	M 3LA 4	1410	14.9	●	81.1	81.4	79.9	0.75	5.2	4.5	2.2	2.0	40	17	FD 15	40	2400	4400	2400	58	27	40	4400	58	28	
3	M 3LB 4	1410	20	●	82.6	83.8	83.7	0.77	6.8	5.0	2.3	2.2	54	21	FD 15	55	—	1300	—	65	29	40	1300	65	30	
4	M 3LC 4	1400	27	○	82.7	83.1	80.5	0.78	9.0	4.7	2.3	2.2	61	23	FD 55	75	—	1050	—	223	55	75	1050	223	56	
5.5	M 45A 4	1440	36	●	84.7	84.8	82.5	0.81	11.6	5.5	2.3	2.2	213	42	FD 56	100	—	950	—	280	64	100	950	280	65	
7.5	M 4LA 4	1440	50	●	86.0	86.3	85.3	0.81	15.5	5.7	2.5	2.4	270	51	FD 06	150	—	900	—	342	73	150	900	342	75	
9.2	M 4LB 4	1440	61	●	88.4	88.6	87.5	0.81	18.8	5.9	2.7	2.5	319	57	FD 07	150	—	850	—	382	81	150	850	382	83	
11	M 4LC 4	1440	73	●	87.6	87.8	86.0	0.81	22.4	6.0	2.7	2.5	360	65	FD 07	200	—	750	—	725	115	200	750	725	114	
15	M 55B 4	1460	98	●	88.7	88.5	88.4	0.81	30.1	6.0	2.3	2.1	650	85	FD 08	250	—	700	—	865	131	250	700	865	130	
18.5	M 5LA 4	1460	121	●	89.3	89.5	89.2	0.81	37	6.2	2.6	2.5	790	101	FD 08											

○ = n.a. ● = IE1



6P **1000 min⁻¹ - S1** **50 Hz**

P _n kW		n min ⁻¹	M _n Nm	IE1	η (100%) %	η (75%) %	η (50%) %	cosφ	I _n 400V A	I _s I _n	M _s M _n	M _a M _n	J _m x 10 ⁻⁴ kgm ²	IM B5 	G.S. Bremse								W.S. Bremse							
															FD				FA				FD				FA			
															Mod	Mb Nm	Z ₀ 1/h	NB	SB	J _m x 10 ⁻⁴ kgm ²	IM B5 	Mod	Mb Nm	Z ₀ 1/h	NB	SB	J _m x 10 ⁻⁴ kgm ²	IM B5 	Mod	Mb Nm
0.09	M 05A	6	0.98	○	41.0	41.0	32.9	0.53	0.60	2.1	2.1	1.8	3.4	4.3	FD 02	3.5	9000	14000	—	—	4.0	6.0	FA 02	3.5	14000	4.0	5.8			
0.12	M 05B	6	1.32	○	45.0	44.0	41.8	0.60	0.64	2.1	1.9	1.7	3.7	4.6	FD 02	3.5	9000	14000	—	—	4.3	6.3	FA 02	3.5	14000	4.3	6.1			
0.18	M 15C	6	1.91	○	55.0	55.5	51.0	0.69	0.68	2.6	1.9	1.7	8.4	5.1	FD 03	5	8100	13500	—	—	9.5	7.8	FA 03	5	13500	9.5	7.5			
0.25	M 15D	6	2.7	○	62.0	58.5	51.4	0.71	0.82	2.6	1.9	1.7	10.9	6.3	FD 03	5	7800	13000	—	—	12	9.0	FA 03	5	13000	12	8.7			
0.37	M 1LA	6	3.9	○	66.0	60.0	53.3	0.69	1.17	3.0	2.4	2.0	12.9	7.3	FD 53	7.5	5100	9500	—	—	14	10.0	FA 03	7.5	9500	14	9.7			
0.55	M 25A	6	5.7	○	70.0	69.8	64.3	0.68	1.67	3.9	2.6	2.2	25	10.6	FD 04	15	4800	7200	—	—	27	14.5	FA 04	15	7200	27	14.4			
0.75	M 25B	6	7.8	●	70.0	70.0	64.4	0.65	2.38	3.8	2.5	2.2	28	11.5	FD 04	15	3400	6400	—	—	30	15.4	FA 04	15	6400	30	15.3			
1.1	M 35A	6	11.4	●	75.0	74.0	72.0	0.72	2.9	4.3	2.0	1.8	33	17	FD 15	26	2700	5000	—	—	37	23	FA 15	26	5000	37	24			
1.5	M 3LA	6	15.2	●	75.2	74.2	70.3	0.72	4.0	4.1	2.1	2.0	82	21	FD 15	40	1900	4100	—	—	86	27	FA 15	40	4100	86	28			
1.85	M 3LB	6	19.0	●	76.6	72.8	62.6	0.73	4.8	4.6	2.1	2.0	95	23	FD 15	40	1700	3600	—	—	99	29	FA 15	40	3600	99	30			
2.2	M 3LC	6	23	●	77.7	76.8	72.4	0.71	5.8	4.7	2.3	2.1	95	23	FD 55	55	—	1900	—	—	99	29	FA 15	40	1900	99	30			
3	M 45A	6	30	●	79.7	77.0	75.1	0.76	7.1	5.1	1.9	1.8	216	34	FD 56	75	—	1400	—	—	226	47	FA 06	75	1400	226	48			
4	M 4LA	6	40	●	81.4	81.5	79.5	0.77	9.2	5.5	2.0	1.8	295	43	FD 06	100	—	1200	—	—	305	56	FA 07	100	1200	305	57			
5.5	M 4LB	6	56	●	83.1	80.9	79.1	0.78	12.2	6.1	2.1	1.9	383	54	FD 07	150	—	1050	—	—	406	70	FA 07	150	1050	406	72			
7.5	M 55A	6	75	●	85.0	85.0	84.8	0.81	15.7	5.9	2.2	2.0	740	69	FD 08	170	—	900	—	—	815	98	FA 08	170	900	800	98			
11	M 55B	6	109	●	86.4	86.5	85.9	0.81	22.7	6.6	2.5	2.3	970	89	FD 08	200	—	800	—	—	1045	119	FA 08	200	800	1030	118			

○ = n.a. ● = IE1

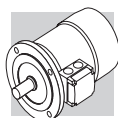



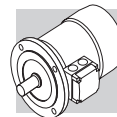

2/4P		3000/1500 min ⁻¹ - S1														50 Hz							
		G.S. Bremse														W.S. Bremse							
		FD							FA							FA							
P _n kW		n min ⁻¹	M _n Nm	η %	cos φ	I _n 400V A	I _s I _n	M _s M _n	M _a M _n	J _m x 10 ⁻⁴ kgm ²	IM B5 Kg	Mod	Mb Nm	Z ₀ 1/h	J _m x 10 ⁻⁴ kgm ²	IM B5 Kg	Mod	Mb Nm	Z ₀ 1/h	J _m x 10 ⁻⁴ kgm ²	IM B5 Kg		
0.20	M 05A	2	2700	0.71	55	0.82	0.64	3.5	2.1	1.9	2.9	4.1	FD 02	3.5	2200	2600	5100	FA 02	3.5	2600	5100	3.5	5.6
0.15		4	1350	1.06	49	0.67	2.6	1.8	1.7														
0.28	M 1SB	2	2700	0.99	56	0.82	0.88	2.9	1.9	1.7	4.7	4.0	FD 03	3.5	2100	2400	4800	FA 03	3.5	2400	4800	5.8	6.4
0.20		4	1370	1.39	59	0.68	1.02	3.1	1.8	1.7													
0.37	M 1SC	2	2740	1.29	56	0.82	1.16	3.5	1.8	1.8	5.8	4.7	FD 03	5	1400	2100	4200	FA 03	5	2100	4200	6.9	7.1
0.25		4	1390	1.72	60	0.73	0.82	3.3	2.0	1.9													
0.45	M 1SD	2	2780	1.55	63	0.85	1.21	3.8	1.8	1.8	6.9	5.5	FD 03	5	1400	2100	4200	FA 03	5	2100	4200	8.0	7.9
0.30		4	1400	2.0	63	0.74	0.93	3.8	2.1	1.9													
0.55	M 1LA	2	2800	1.9	73	0.79	1.38	4.2	2.0	1.8	9.1	6.9	FD 03	5	1600	2200	4600	FA 03	5	2200	4600	10.2	9.3
0.37		4	1400	2.5	68	0.72	1.09	3.9	2.2	2.0													
0.75	M 2SA	2	2780	2.6	65	0.85	1.96	3.8	1.9	1.8	20	9.2	FD 04	10	1400	1600	3600	FA 04	10	1600	3600	22	13.0
0.55		4	1400	3.8	68	0.81	1.44	3.9	1.7	1.7													
1.1	M 2SB	2	2730	3.9	65	0.86	2.84	3.9	2.0	1.9	25	10.7	FD 04	10	1200	1500	3100	FA 04	10	1500	3100	27	14.5
0.75		4	1410	5.1	75	0.81	1.78	4.5	2.1	2.0													
1.5	M 3SA	2	2830	5.1	74	0.83	3.5	4.7	2.1	2.0	34	15.5	FD 15	26	700	1000	2600	FA 15	26	1000	2600	38	23
1.1		4	1420	7.4	77	0.78	2.6	4.3	2.1	2.0													
2.2	M 3LA	2	2800	7.5	72	0.85	5.2	4.5	2.0	1.9	40	17	FD 15	26	600	900	2300	FA 15	26	900	2300	44	24
1.5		4	1410	10.2	73	0.79	3.8	4.7	2.0	2.0													
3.5	M 3LB	2	2850	11.7	80	0.84	7.5	5.4	2.2	2.1	61	23	FD 15	40	500	900	2100	FA 15	40	900	2100	65	30
2.5		4	1420	16.8	82	0.80	5.5	5.2	2.2	2.2													
4.8	M 4 SA	2	2900	15.8	81	0.88	9.7	6.0	2.0	1.9	213	42	FD 06	50	—	400	—	FA 06	50	400	—	233	56
3.8		4	1430	25.4	81	0.84	8.1	5.2	2.1	2.1													
5.5	M 4SB	2	2890	18.2	80	0.87	11.4	5.9	2.4	2.0	213	42	FD 56	75	—	350	—	FA 06	75	350	—	223	56
4.4		4	1440	29	82	0.84	9.2	5.3	2.2	2.0													
7.5	M 4LA	2	2900	25	82	0.87	15.2	6.5	2.4	2.0	270	51	FD 06	100	—	350	—	FA 07	100	350	—	280	65
6		4	1430	40	84	0.85	12.1	5.8	2.3	2.1													
9.2	M 4LB	2	2920	30	83	0.86	18.6	6.0	2.6	2.2	319	57	FD 07	150	—	300	—	FA 07	150	300	—	342	75
7.3		4	1440	48	85	0.85	14.6	5.5	2.3	2.1													

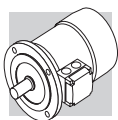

2/6P **3000/1000 min⁻¹ - S3 60/40%** **50 Hz**



P _n kW		G.S. Bremse														W.S. Bremse								
		FD							FA							FA								
		IM B5	J _m x 10 ⁻⁴ kgm ²	Ma Mn	Ms Mn	Is In	In 400V A	cosφ	η	M _n Nm	n min ⁻¹	M _n Nm	Mod	Mb Nm	Z ₀ 1/h	NB	SB	J _m x 10 ⁻⁴ kgm ²	IM B5	Mod	Mb Nm	Z ₀ 1/h	J _m x 10 ⁻⁴ kgm ²	IM B5
0.25	M 1SA	2	2850	0.84	60	0.82	0.73	4.3	1.9	1.8	6.9	5.5	FD 03	1.75	1500	1700	8.0	8.2	FA 03	1.75	1700	8.0	8.0	7.9
0.08		6	910	0.84	43	0.70	0.38	2.1	1.4	1.5	10000	13000												
0.37	M 1LA	2	2880	1.23	62	0.80	1.08	4.4	1.9	1.8	9.1	6.9	FD 03	3.5	1000	1300	10.2	9.6	FA 03	3.5	1300	10.2	10.2	9.3
0.12		6	900	1.27	44	0.73	0.54	2.4	1.4	1.5	9000	11000												
0.55	M 2SA	2	2800	1.88	63	0.86	1.47	4.5	1.9	1.7	20	9.2	FD 04	5	1500	1800	22	13.1	FA 04	5	1800	22	22	13.0
0.18		6	930	1.85	52	0.65	0.77	3.3	2.0	1.9	4100	6300												
0.75	M 2SB	2	2800	2.6	66	0.87	1.89	4.3	1.8	1.6	25	10.6	FD 04	5	1700	1900	27	14.5	FA 04	5	1900	27	27	14.4
0.25		6	930	2.6	54	0.67	1.00	3.2	1.7	1.8	3800	6000												
1.1	M 3SA	2	2870	3.7	71	0.82	2.73	4.9	1.8	1.9	34	15.5	FD 15	13	1000	1300	38	22	FA 15	13	1300	38	38	23
0.37		6	930	3.8	63	0.70	1.21	3.1	1.5	1.8	3500	5000												
1.5	M 3LA	2	2880	5.0	73	0.84	3.53	5.1	1.9	2.0	40	17	FD 15	13	1000	1200	44	24	FA 15	13	1200	44	44	24
0.55		6	940	5.6	64	0.67	1.85	3.5	1.7	1.8	2900	4000												
2.2	M 3LB	2	2900	7.2	77	0.85	4.9	5.9	2.0	2.0	61	23	FD 15	26	700	900	65	29	FA 15	26	900	65	65	30
0.75		6	950	7.5	67	0.64	2.5	3.3	1.9	1.8	2100	3000												
3	M 4SA	2	2910	9.9	74	0.88	6.6	5.6	2.0	2.1	170	36	FD 56	37	—	600	182	48	FA 06	37	600	182	182	50
1.1		6	960	10.9	73	0.68	3.2	4.5	2.2	2.0	—	—												
4.5	M 4SB	2	2910	14.8	78	0.84	9.9	5.8	1.9	1.8	213	42	FD 56	37	—	500	223	55	FA 06	37	500	223	223	56
1.5		6	960	14.9	74	0.67	4.4	4.2	1.9	2.0	—	—												
5.5	M 4LA	2	2920	18.0	78	0.87	11.7	6.2	2.1	1.9	270	51	FD 06	50	—	400	280	64	FA 06	50	400	280	280	65
2.2		6	960	22	77	0.71	5.8	4.3	2.1	2.0	—	—												



2/8P		3000/750 min ⁻¹ - S3 60/40%														50 Hz									
		G.S. Bremse														W.S. Bremse									
		FD							FA							FA		FA							
P _n kW		n min ⁻¹	M _n Nm	η %	cos φ	I _n 400V A	$\frac{I_s}{I_n}$	$\frac{M_s}{M_n}$	$\frac{M_a}{M_n}$	J _m x 10 ⁻⁴ kgm ²	IM B5 	Mod	Mb Nm	Z ₀ 1/h	NB	SB	J _m x 10 ⁻⁴ kgm ²	IM B5 	Mod	Mb Nm	Z ₀ 1/h	J _m x 10 ⁻⁴ kgm ²	IM B5 		
0.37	M 1LA	2	1.26	63	0.86	0.99	3.9	1.8	1.9	12.9	7.3	FD 03	3.5	1200	9500	1300	13000	14	10.0	FA 03	3.5	1300	13000	14	9.7
0.09		8	1.28	34	0.75	0.51	1.8	1.4	1.5																
0.55	M 2SA	2	1.86	66	0.86	1.40	4.4	2.1	2.0	20	9.2	FD 04	5	1500	8000	1800	8000	22	13.1	FA 04	5	1800	8000	22	13.0
0.13		8	1.80	41	0.64	0.72	2.3	1.6	1.7																
0.75	M 2SB	2	2.6	68	0.88	1.81	4.6	2.1	2.0	25	10.6	FD 04	10	1700	7300	1900	7300	27	14.5	FA 04	10	1900	7300	27	14.4
0.18		8	2.5	43	0.66	0.92	2.3	1.6	1.7																
1.1	M 3SA	2	3.7	69	0.84	2.74	4.6	1.8	1.7	34	15.5	FD 15	13	1000	3400	1300	5000	38	22	FA 15	13	1300	5000	38	23
0.28		8	3.9	44	0.56	1.64	2.3	1.4	1.7																
1.5	M 3LA	2	5.0	69	0.85	3.69	4.7	1.9	1.8	40	17	FD 15	13	1000	3300	1200	5000	44	24	FA 15	13	1200	5000	44	24
0.37		8	5.1	46	0.63	1.84	2.1	1.6	1.6																
2.4	M 3LB	2	7.9	75	0.82	5.6	5.4	2.1	2.0	61	23	FD 15	26	550	2000	700	3500	65	29	FA 15	26	700	3500	65	30
0.55		8	7.5	54	0.58	2.5	2.6	1.8	1.8																
3	M 4SA	2	9.8	72	0.85	7.1	5.6	2.0	1.8	162	36	FD 56	37	—	—	600	3400	182	48	FA 06	37	600	3400	182	50
0.75		8	10.1	61	0.64	2.8	3.0	1.7	1.8																
4	M 4SB	2	13.3	73	0.84	9.4	5.6	2.3	2.4	213	42	FD 56	37	—	—	500	3500	223	55	FA 06	37	500	3500	223	56
1		8	13.8	66	0.62	3.5	2.9	1.9	1.8																
5.5	M 4LA	2	18.3	75	0.84	12.6	6.1	2.4	2.5	270	51	FD 06	50	—	—	400	2400	280	64	FA 06	50	400	2400	280	65
1.5		8	21	68	0.63	5.1	2.9	1.9	1.9																



2/12P **3000/500 min⁻¹ - S3 60/40%** **50 Hz**

P _n kW			n min ⁻¹	M _n Nm	η %	cos φ	I _n 400V A	I _s I _n	M _s M _n	M _a M _n	J _m x 10 ⁻⁴ kgm ²	IM B5 	G.S. Bremse				W.S. Bremse											
													FD		FA		FD		FA									
													Mod	Mb Nm	Z _o 1/h	NB	SB	Mod	Mb Nm	Z _o 1/h	J _m x 10 ⁻⁴ kgm ²	IM B5 						
0.55	0.09	M 2SA	2 12	2820 430	1.86 2.0	64 30	0.89 0.63	1.39 0.69	4.2 1.8	1.6 1.9	1.7 1.8	25	10.6	5	1000	1300	8000	12000	14.5	14.5	27	27	5	1300	12000	27	27	14.4
0.75	0.12	M 3SA	2 12	2900 460	2.5 2.5	65 33	0.81 0.43	2.06 1.22	5.2 1.9	1.9 1.3	2.1 1.6	34	15.5	13	700	900	5000	7000	22	22	38	38	13	900	7000	38	38	23
1.1	0.18	M 3LA	2 12	2850 430	3.7 4.0	65 26	0.85 0.54	2.87 1.85	4.5 1.5	1.6 1.3	1.8 1.5	40	17	13	700	900	4000	6000	24	24	44	44	13	900	6000	44	44	24
1.5	0.25	M 3LB	2 12	2900 440	4.9 5.4	67 36	0.86 0.46	3.76 2.18	5.6 1.8	1.9 1.7	1.9 1.8	54	21	13	700	900	3800	5000	27	27	58	58	13	900	5000	58	58	28
2	0.3	M 3LC	2 12	2850 450	6.7 6.4	70 38	0.84 0.47	4.9 2.4	4.9 1.7	1.8 1.6	1.7 1.7	61	23	18	—	700	—	3500	29	29	65	65	18	700	3500	65	65	30
3	0.5	M 4SA	2 12	2920 470	9.8 10.2	74 51	0.87 0.43	6.7 3.3	6.8 2.0	2.3 1.7	1.9 1.6	213	42	37	—	450	—	3000	55	55	223	223	37	450	3000	223	223	56
4	0.7	M 4LA	2 12	2920 460	13.1 14.5	75 53	0.89 0.44	8.6 4.3	5.9 1.9	2.4 1.7	2.3 1.6	270	51	37	—	400	—	2800	64	64	280	280	37	400	2800	280	280	65



M21 MOTORENABMESSUNGEN BN-M

BN - IM B5

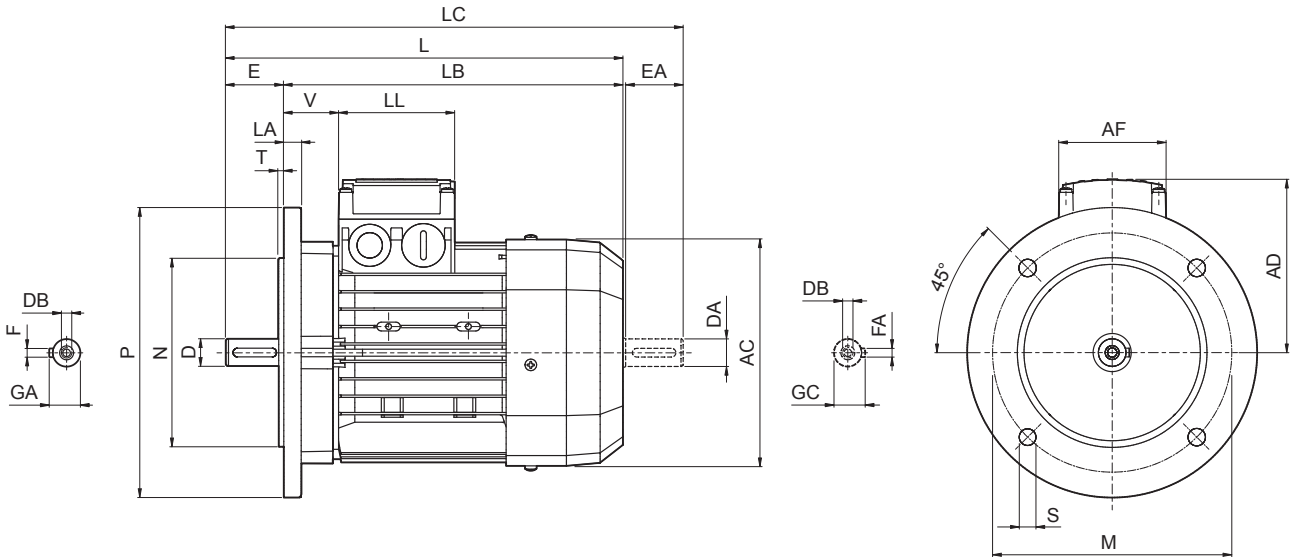

BN-M

	Welle					Flansch					Motor								
	D DA	E EA	DB	GA GC	F FA	M	N	P	S	T	LA	AC	L	LB	LC	AD	AF	LL	V
BN 56	9	20	M3	10.2	3	100	80	120	7	3	8	110	185	165	207	91	74	80	34
BN 63	11	23	M4	12.5	4	115	95	140	9.5		10	121	207	184	232	95			26
BN 71	14	30	M5	16	5	130	110	160			11.5	11.5	138	249	219	281			108
BN 80	19	40	M6	21.5	6	165	130	200	11.5	3.5	15	156	274	234	315	119	98	98	38
BN 90	24	50	M8	27	8						14	176	326	276	378	133			44
BN 100	28	60	M10	31	8	215	180	250	14	4	14	195	367	307	429	142	118	118	50
BN 112											15	219	385	325	448	157			52
BN 132	38	80	M12	41	10	265	230	300	18.5	5	20	258	493	413	576	193	187	187	58
BN 160 MR	42 38 ⁽¹⁾	110 80 ⁽¹⁾	M16 M12 ⁽¹⁾	45 41 ⁽¹⁾	12 10 ⁽¹⁾	300	250	350			15		310	596	486				680
BN 160 M									18	310	640	530	724	261	51				
BN 160 L	48 38 ⁽¹⁾	110 110 ⁽¹⁾	M16 M16 ⁽¹⁾	51.5 41 ⁽¹⁾	14 10 ⁽¹⁾	350	300	400	18.5	5	15	310	640	530	724	187	187	51	
BN 180 M											18	348	708	598	823	261	52		
BN 180 L	48 42 ⁽¹⁾	110 110 ⁽¹⁾	M16 M16 ⁽¹⁾	51.5 45 ⁽¹⁾	14 12 ⁽¹⁾	350	300	400	18.5	5	18	348	722	612	837	261	66		
BN 200 L	55 42 ⁽¹⁾	110 110 ⁽¹⁾	M20 M16 ⁽¹⁾	59 45 ⁽¹⁾	16 12 ⁽¹⁾						350	300	400	18.5	5	18	348	722	612

HINWEIS:

1) Diese Maße betreffen das zweite Wellenende.



BN - IM B14

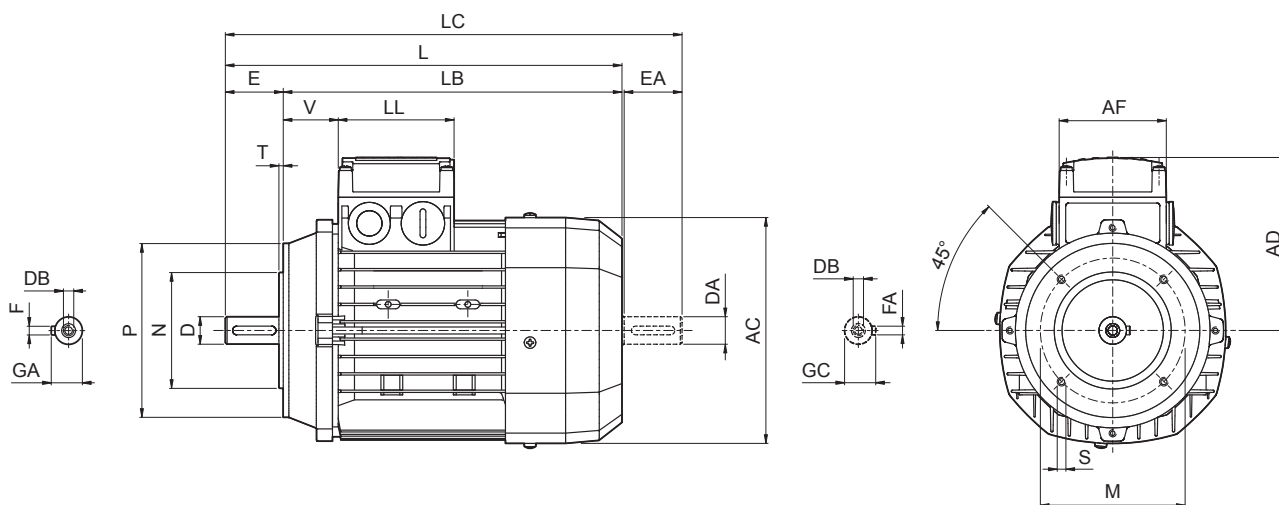

BN-M

	Welle					Flansch					Motor							
	D DA	E EA	DB	GA GC	F FA	M	N	P	S	T	AC	L	LB	LC	AD	AF	LL	V
BN 56	9	20	M3	10.2	3	65	50	80	M5	2.5	110	185	165	207	91	74	80	34
BN 63	11	23	M4	12.5	4	75	60	90			121	207	184	232	95			26
BN 71	14	30	M5	16	5	85	70	105	M6	3	138	249	219	281	108	74	80	37
BN 80	19	40	M6	21.5	6	100	80	120			156	274	234	315	119			38
BN 90	24	50	M8	27	8	115	95	140	M8	3.5	176	326	276	378	133	98	98	44
BN 100	28	60	M10	31		130	110	160			195	367	307	429	142			98
BN 112					219	385	325	448	157	52								
BN 132	38	80	M12	41	10	165	130	200	M10	4	258	493	413	576	193	118	118	58

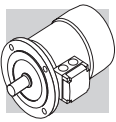

BN_FD ; IM B5

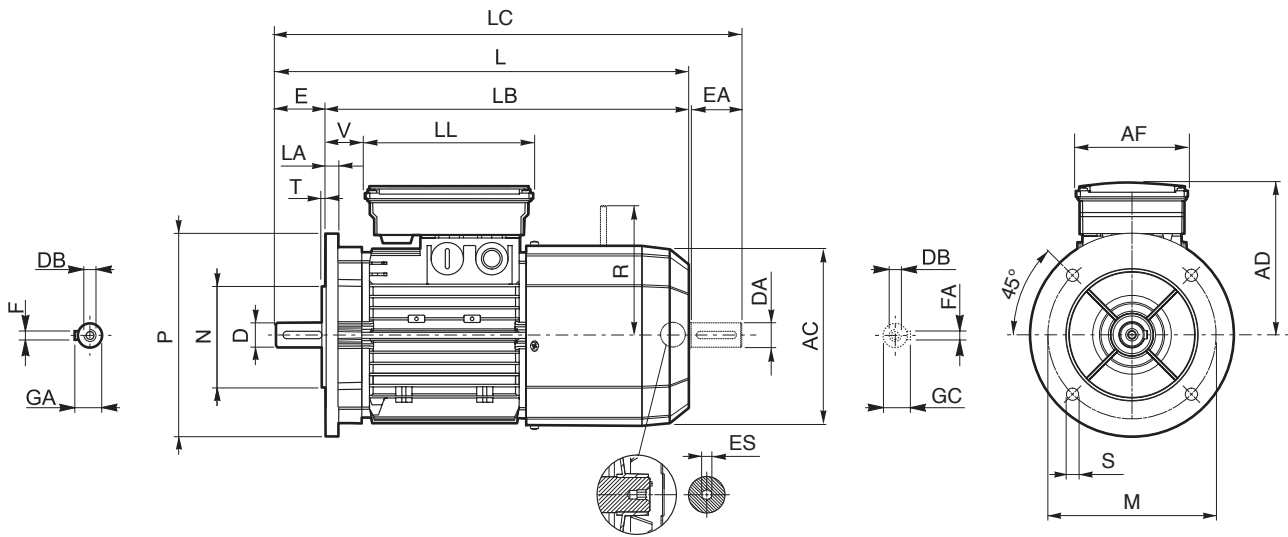

BN-M

	Welle					Flansch					Motor										
	D DA	E EA	DB	GA GC	F FA	M	N	P	S	T	LA	AC	L	LB	LC	AD	AF	LL	V	R	ES
BN 63	11	23	M4	12.5	4	115	95	140	9.5	3	10	121	272	249	297	122	98	133	14	96	5
BN 71	14	30	M5	16	5	130	110	160	9.5	3.5		138	310	280	342	135			25	103	
BN 80	19	40	M6	21.5	6	165	130	200	11.5			156	346	306	388	146			41	129	
BN 90 S	24	50	M8	27	8					215	180	250	14	4	11.5	176	409	359	461	149	110
BN 90 L						146	165	62													
BN 100	28	60	M10	31	10	265	230	300	14	4	20	14	195	458	398	521	158	140	165	73	199
BN 112												15	219	484	424	547	173		62	165	
BN 132	38	80	M12	41	10	265	230	300	14	4	20	258	603	523	686	210	140	188	46	204 ⁽²⁾	6
BN 160 MR	42	110	M16	45	12	300	250	350					18.5	5	15			310	672	562	
BN 160 M	38 ⁽¹⁾								41 ⁽¹⁾	10 ⁽¹⁾	51	266									
BN 160 L	42	80 ⁽¹⁾	M12 ⁽¹⁾	51.5	14	300	250	350	18.5	5	15	310	736	626	820	245	187	187	51	266	—
BN 180 M	48	38 ⁽¹⁾	M16																41 ⁽¹⁾	10 ⁽¹⁾	
BN 180 L	48	110	M16	45 ⁽¹⁾	12 ⁽¹⁾	350	300	400	18.5	5	18	348	866	756	981	261	187	187	64	305	
BN 200 L	55		M20	59	16														12 ⁽¹⁾	878	768

HINWEIS:

- 1) Diese Maße betreffen das zweite Wellenende.
- 2) Für Bremse FD07, Maß R=226.

Der Sechskant ES ist bei der Option PS nicht vorhanden.



BN_FD ; IM B14

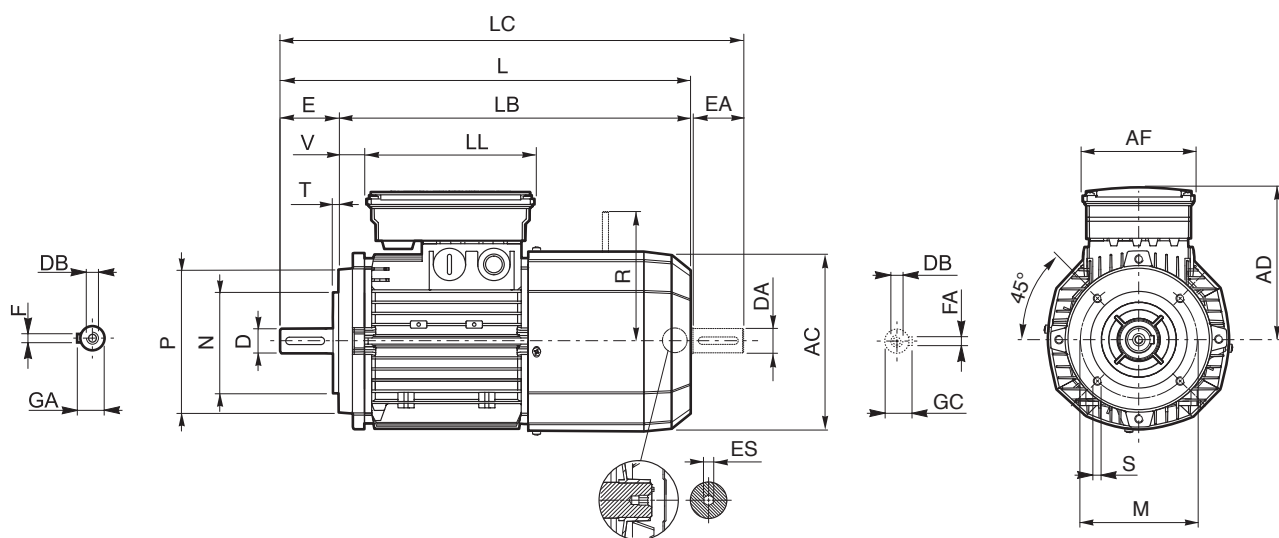

BN-M

	Welle					Flansch					Motor									
	D DA	E EA	DB	GA GC	F FA	M	N	P	S	T	AC	L	LB	LC	AD	AF	LL	V	R	ES
BN 63	11	23	M4	12.5	4	75	60	90	M5	2.5	121	272	249	297	122	98	133	14	96	5
BN 71	14	30	M5	16	5	85	70	105	M6		138	310	280	342	135			25	103	
BN 80	19	40	M6	21.5	6	100	80	120			156	346	306	388	146			41	129	
BN 90 S	24	50	M8	27	8	115	95	140	M8	3	176	409	359	461	110	165	39	129	6	
BN 90 L																				146
BN 100	28	60	M10	31		130	110	160		3.5	195	458	398	521			158	62		199
BN 112											219	484	424	547			173	73		199
BN 132	38	80	M12	41	10	165	130	200	M10	4	258	603	523	686	210	140	188	46	204 ⁽¹⁾	

HINWEIS:

1) Für Bremse FD07, Maß R=226.

Der Sechskant ES ist bei der Option PS nicht vorhanden.

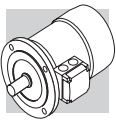

BN_FA - IM B5

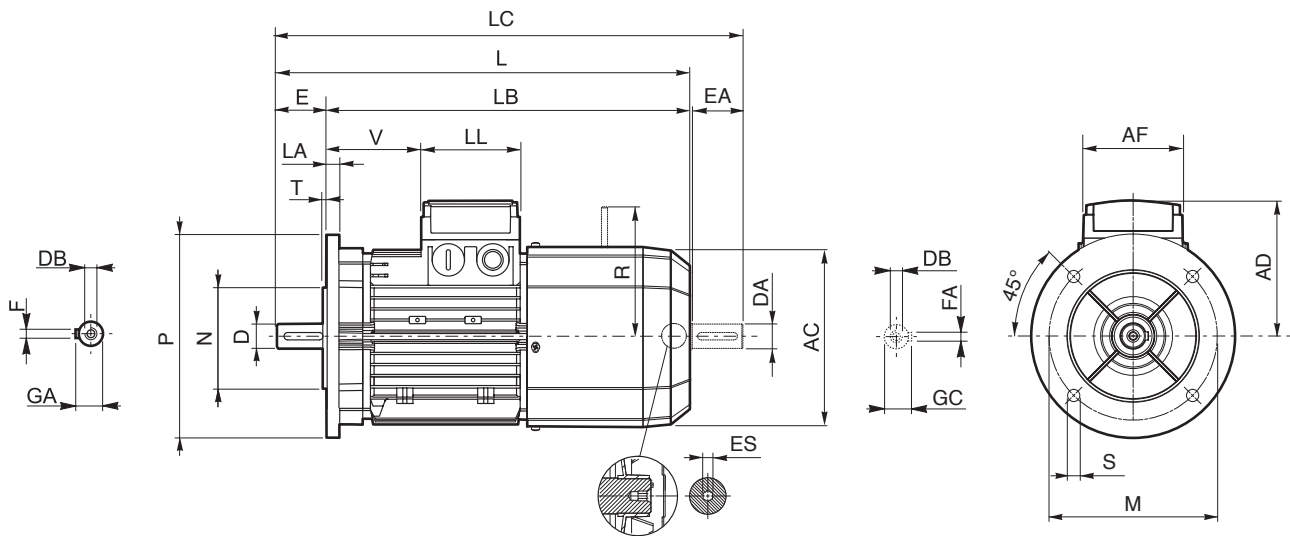

BN-M

	Welle					Flansch					Motor										
	D DA	E EA	DB	GA GC	F FA	M	N	P	S	T	LA	AC	L	LB	LC	AD	AF	LL	V	R	ES
BN 63	11	23	M4	12.5	4	115	95	140	9.5	3	10	121	272	249	297	95	74	80	26	116	5
BN 71	14	30	M5	16	5	130	110	160				138	310	280	342				108	68	
BN 80	19	40	M6	21.5	6	165	130	200	11.5	3.5	11.5	156	346	306	388	119	98	98	83	134	6
BN 90	24	50	M8	27	176							409	359	461	133	95			160		
BN 100	28	60	M10	31	8	215	180	250	14	4	14	195	458	398	521	142	98	98	119	198	6
BN 112											15	219	484	424	547	157			128		
BN 132	38	80	M12	41	10	265	230	300	14	5	15	20	603	523	686	210	140	188	46	200 ⁽²⁾	—
BN 160 MR	42 38 ⁽¹⁾	110 80 ⁽¹⁾	M16 M12 ⁽¹⁾	45 41 ⁽¹⁾	12 10 ⁽¹⁾	300	250	350				18.5	5	15	258	672	562	755	193	118	
BN 160 M									310	736	626				820	245	187	187	51	247	
BN 160 L									780	670	864				245	187	187	51	247		
BN 180 M	48 38 ⁽¹⁾	110 80 ⁽¹⁾	M16 M12 ⁽¹⁾	51.5 41 ⁽¹⁾	14 10 ⁽¹⁾	300	250	350	18.5	5	15	310	780	670	864	245	187	187	51	247	—

HINWEIS:

- 1) Diese Maße betreffen das zweite Wellenende.
- 2) Für Bremse FA07, Maß R=217.

Die Abmessungen des Klemmkastens der Motoren BN ... FA AD, AF, LL und V in Bezug auf die separate Spannungsversorgung (Option SA) stimmen mit den Abmessungen der entsprechenden Motoren BN...FD überein.

Der Sechskant ES ist bei der Option PS nicht vorhanden.

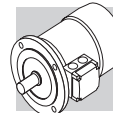

BN_FA - IM B14

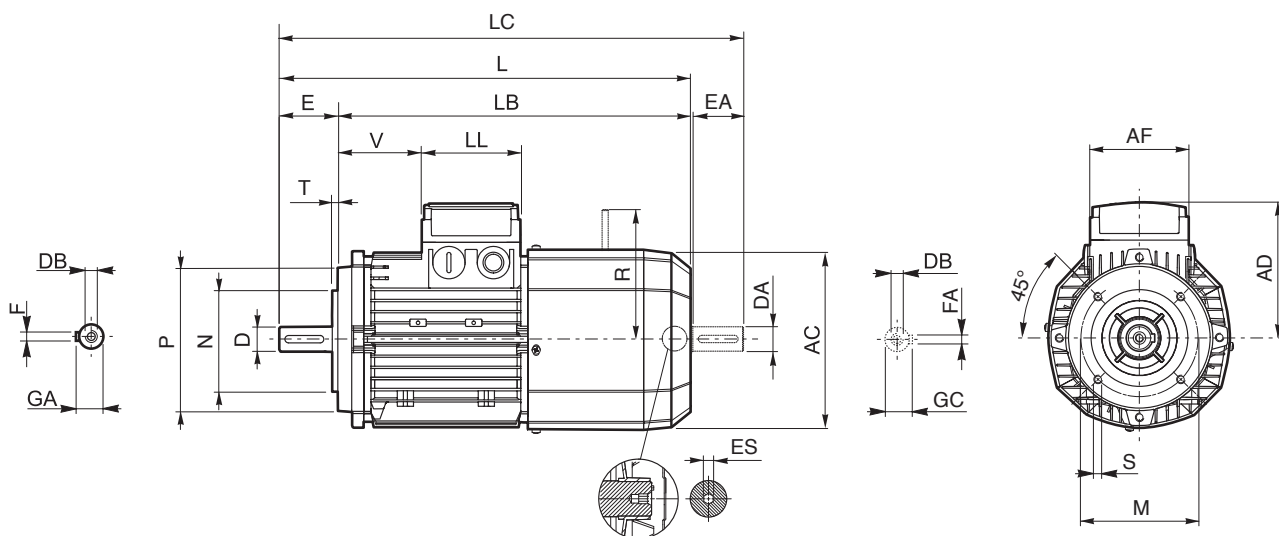

BN-M

	Welle					Flansch					Motor									
	D DA	E EA	DB	GA GC	F FA	M	N	P	S	T	AC	L	LB	LC	AD	AF	LL	V	R	ES
BN 63	11	23	M4	12.5	4	75	60	90	M5	2.5	121	272	249	119	95	74	80	26	116	5
BN 71	14	30	M5	16	5	85	70	105	M6		138	310	280	342	108			68	124	
BN 80	19	40	M6	21.5	6	100	80	120		3	156	346	306	388	119			83	134	
BN 90	24	50	M8	27	8	115	95	140	M8	3.5	176	409	359	461	133	98	98	95	160	6
BN 100	28	60	M10	31		130	110	160			195	458	398	521	142			119	198	
BN 112										219	484	424	547	157	128			198		
BN 132	38	80	M12	41	10	165	130	200	M10	4	258	603	523	686	210	140	188	46	200 ⁽¹⁾	

HINWEIS:

1) Für Bremse FA07, Maß R=217.

Die Abmessungen des Klemmkastens der Motoren BN ... FA AD, AF, LL und V in Bezug auf die separate Spannungsversorgung (Option SA) stimmen mit den Abmessungen der entsprechenden Motoren BN...FD überein.

Der Sechskant ES ist bei der Option PS nicht vorhanden.



M

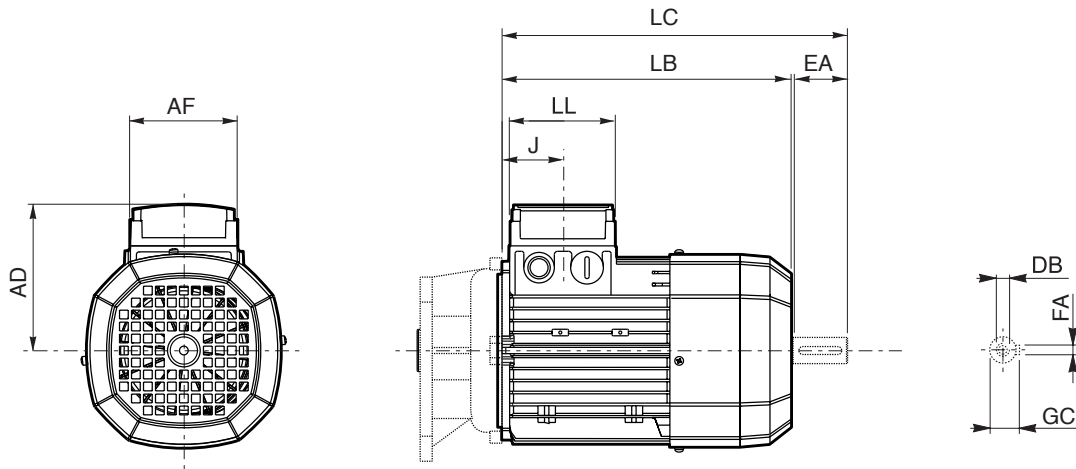

BN-M

	Zweite Wellenende					Motor						
	DA	EA	DB	FA	GC	AC	LB	LC	AF	LL	J	AD
M 0	9	20	M3	3	10.2	110	133	155	74	80	42	91
M 05	11	23	M4	4	12.5	121	165	191			48	95
M 1	14	30	M5	5	16	138	187	219			45	108
M 2 S	19	40	M6	6	21.5	156	202	245			44	119
M 3 S	28	60	M10	8	31	195	230	293	98	98	53.5	142
M 3 L							262	325				
M 4	38	80	M12	10	41	258	361	444	118	118	64.5	193
M 4 LC							396	479				
M 5 S						310	418	502	187	187	77	245
M 5 L							462	546				



M_FD

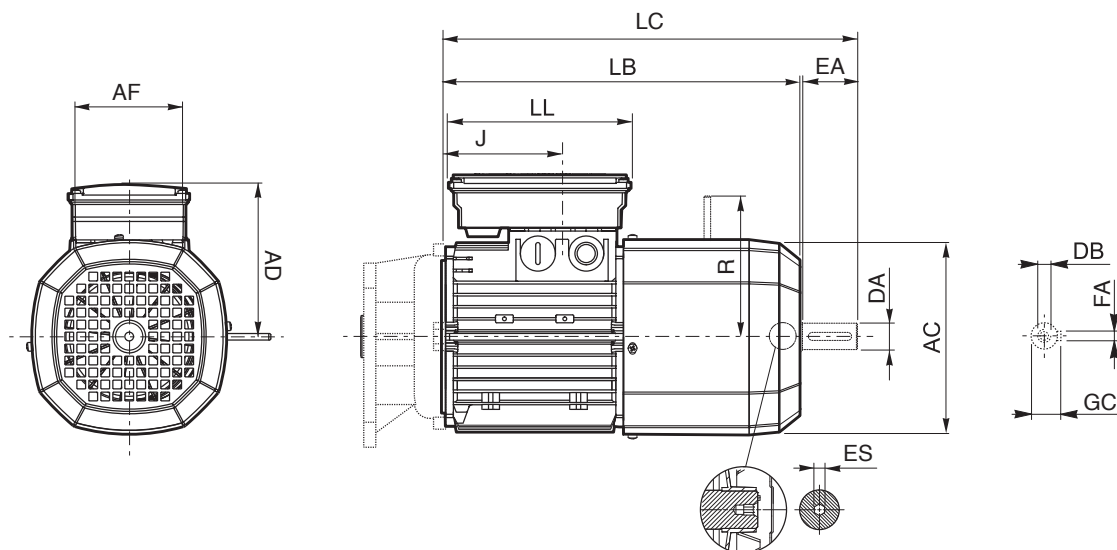

BN-M

	Zweite Wellenende					Motor								
	DA	EA	DB	FA	GC	AC	LB	LC	AF	LL	J	AD	R	ES
M 05	11	23	M4	4	12.5	121	231	256	98	133	48	122	96	5
M 1	14	30	M5	5	16	138	248	280			73	135	103	
M 2 S	19	40	M6	6	21.5	156	272	314			88	146	129	
M 3 S	28	60	M10	8	31	195	326	389	110	165	124.5	158	160	6
M 3 L							353	416						
M 4	38	80	M12	10	41	258	470	553	140	188	185.5	210	204 (1)	
M 4 LC							495	578			64.5		226	
M 5 S						310	558	642	187	187	77	245	266	
M 5 L	602	686												

HINWEIS:

1) Für Bremse FD07, Maß R=226.

Der Sechskant ES ist bei der Option PS nicht vorhanden.



M_FA

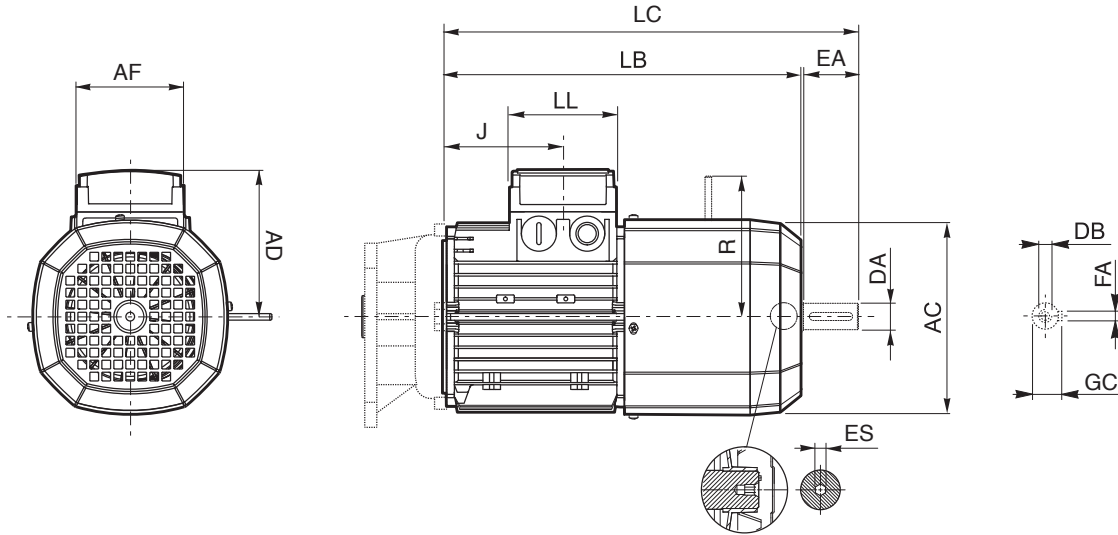

BN-M

	Zweite Wellenende					Motor								
	DA	EA	DB	FA	GC	AC	LB	LC	AF	LL	J	AD	R	ES
M 05	11	23	M4	4	12.5	121	231	256	74	80	48	95	116	5
M 1	14	30	M5	5	16	138	248	280			73	108	124	
M 2 S	19	40	M6	6	21.5	156	272	314			88	119	134	
M 3 S	28	60	M10	8	31	195	326	389	98	98	124.5	142	160	6
M 3 L							353	416						
M 4	38	80	M14	10	41	258	470	553	140	188	185.5	210	200 (1)	
M 4 LC							495	578			64.5		217	
M 5 S			M12			310	558	642	187	187	77	245	247	—
M 5 L	602	686												

HINWEIS:

1) Für Bremse FA07, Maß R=217.

Die Abmessungen des Klemmkastens der Motoren M ...FAAD, AF, LL und V in Bezug auf die separate Spannungsversorgung (Option SA) stimmen mit den Abmessungen der entsprechenden Motoren M...FD überein.

Der Sechskant ES ist bei der Option PS nicht vorhanden.

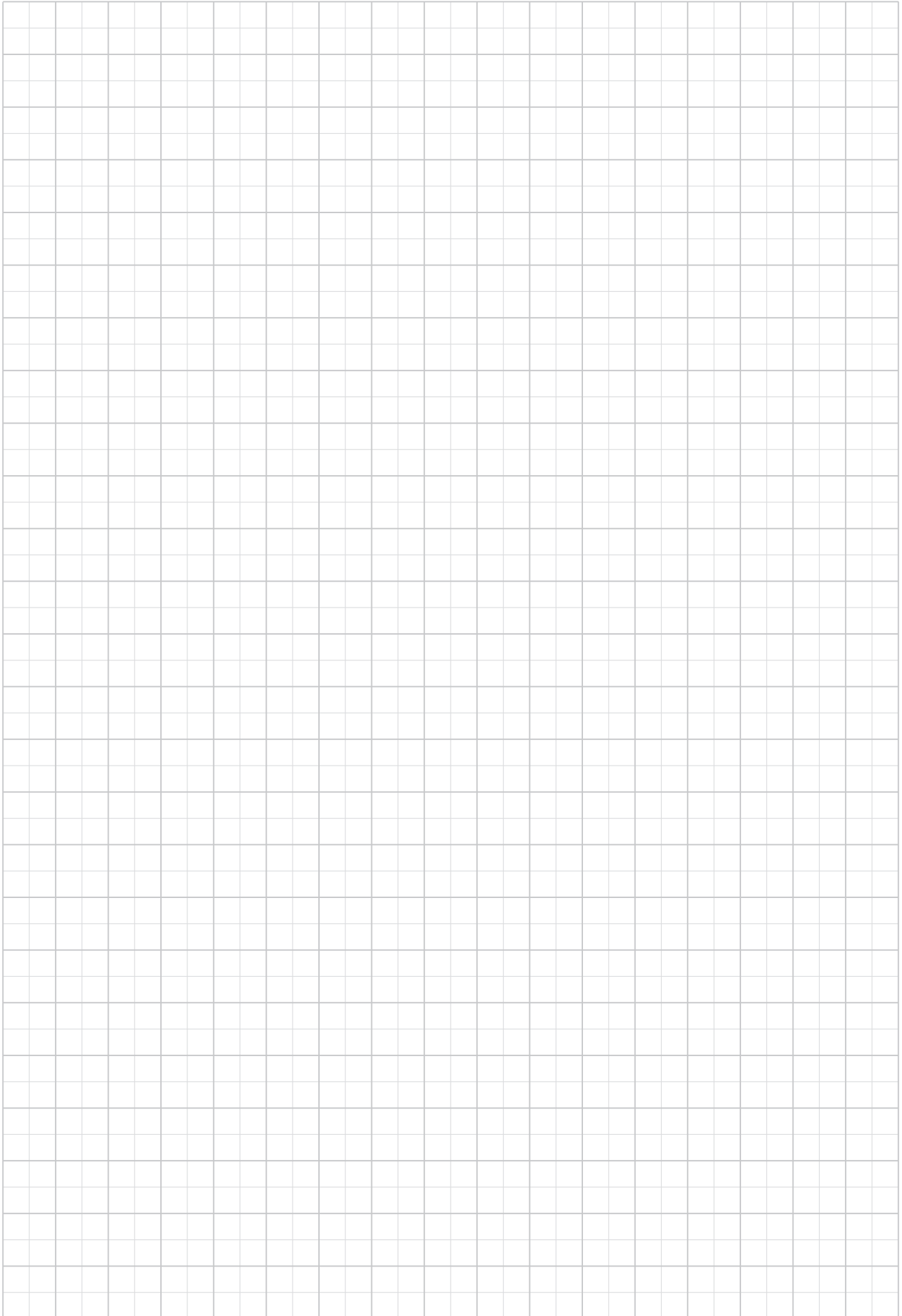



LISTE DER ÄNDERUNGEN

BR_CAT_VFW_IE2-IE3_DEU_R11_4	
	Beschreibung
...	Zusätzliche Verfügbarkeit von BXN- und MXN-Elektromotoren.
20	Aktualisierte Option „Schmierung“.
107	Tabelle „Motor anbaumöglichkeiten“ für Getriebe VF/VF 30/44 und VF/VF 30/49 aktualisiert.
121	Korrigieren Sie die Eigenschaften des Elektromotors BN27.
148...151	Korrekte Befestigungsloch Abmessungen für das W110-Getriebe.
195	Korrigieren Abmessungen für die Getriebe VF 44L und VF 49L.
215...344	Abschnitt Elektromotoren aktualisiert.

2023 12 11

Diese Veröffentlichung annulliert und ersetzt jede vorhergehende Ausgabe oder Revision. BONFIGLIOLI behält sich das Recht vor, Änderungen ohne vorherige Informationen durchzuführen.



Wir verpflichten uns kompromisslos zu Qualität, Innovation und Nachhaltigkeit. Unser Team entwickelt, vertreibt und wartet erstklassige Energieübertragungs- und Antriebslösungen, um die Welt in Bewegung zu halten.

UNTERNEHMENSZENTRALE

Bonfiglioli S.p.A

Firmensitz: Via Cav. Clementino Bonfiglioli, 1
40012 Calderara di Reno - Bologna (Italy)
Tel. +39 051 6473111

Betriebsstätte: Via Isonzo, 65/67/69
40033 Casalecchio di Reno - Bologna (Italy)

