

Solutions for Access & Aerial Platforms

Intralogistics



MARKETS &
APPLICATIONS







Access & Aerial Platforms



Wheel drives
600 Series
600WE Series

Slew drives
700T Series

The most reliable solutions for Access & Aerial Platforms

Bonfiglioli's broad range of products dedicated to aerial platforms guarantees maximum efficiency, optimized spaces, flexibility and ease of maintenance.

From wheel drives to slew drives, we offer reliable and robust solutions certified by decades of proven field tests to leading manufacturers worldwide.

Our experienced team designs hydraulic, hybrid or electric products to fit Bonfiglioli customers' needs. The great quality of the products, as well as the advanced technology we employ, make the company stand out as the ideal partner.

Bonfiglioli also provides solutions for:

 BUILDING CONSTRUCTION

 EARTH-MOVING MACHINES

 ROAD CONSTRUCTION



Wheel drives



600 Series

The Bonfiglioli 600 Series is the best solution when designing wheeled off-road machinery. With a compact design, high torque and load capacities, a negative multi-disk parking brake and an optional disengagement device to tow the vehicle in an emergency, these solutions precisely match the application requirements.



HYDRAULIC SOLUTIONS



ACCESS
PLATFORMS



SCISSOR
PLATFORMS



TELESCOPIC
PLATFORMS

Input speed

- up to 4,000 rpm

Brake options

- Hydraulically released parking brake on request

Applicable motors

- Cartridge axial piston hydraulic motors
- Flanged axial piston hydraulic motors
- Hydraulic orbit motors
- DC electric motor brake

Main options

- Dynamic & service brake

Key features

- Rotating housing flange with studs to fit wheels and drums
- Rugged design
- High torque capacity
- High load capacity
- Mechanical lifetime seals
- Compact design
- Optional mechanical gear disengagement on request

Torque (Nm)

601R1L	3,000
603W2.H	5,000
603W2VB	7,000
605W2V.	10,000
606W.V	18,000



Type	Ratios	Max Input Speed	Max Brake Torque at Motor Shaft (Static)	Weight	Oil Quantity	Orbital Hyd. Motor	Hydraulic Piston Mot.	Machine Ton Class
	1:	rpm	Nm	kg	L			ton
601R1	4.26 - 5.77	1,000	560	35	0.7	•		4 ÷ 7
603W2V H	19.5 - 40.5	4,000	210	45	0.5	•	•	7 ÷ 12
603W2L H	14 - 40.5	4,000	210	45	0.6	•	•	7 ÷ 12
603W2V B	21.6 - 53	4,000	166	45	1.3		•	7 ÷ 12
605W2 H	22.2 - 53	3,500	310	60	1	•	•	12 ÷ 18
605W2 B	22.2 - 53	3,500	300	53	1.4	•		12 ÷ 18
606W2	19.7 - 43.8	3,500	460	110	2	•	•	18 ÷ 25
606W3	68 - 128.6	3,500	330	128	1.8		•	18 ÷ 25

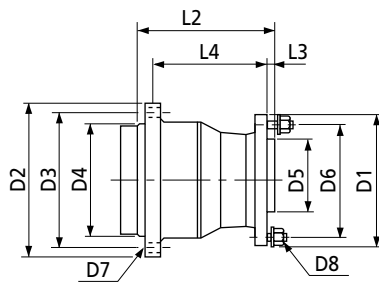

R version

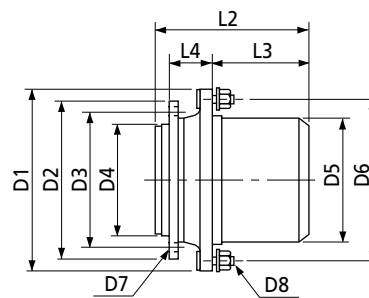

W version

Type	L2	L3	L4	D1	D2	D3	D4	D5	D6	D7	D8
601R1L	245	10	195	230	260	230	200	152.4	203.2	Ø15 n. 8	M14x1.5 n. 8
603W2V H	236	128	72	280	270	230	190	200	241.3	M16x2 n. 8	M18x1.5 n. 9
603W2L H	249.5	25	175	237	270	230	190	160	205	M16x2 n. 8	M18x1.5 n. 6
603W2V B	249	108	106	275	240	210	178	200	241.3	M16x2 n. 9	M16x1.5 n. 9
605W2 H	240	154	72	300	270	230	190	220	260	M16x2 n. 8	M16x1.5 n. 8
605W2 B	218	136	72	310	260	230	190	220	275	M16x2 n.12	M20x1.5 n. 8
606W2	270	155	115	370	330	300	270	280	335	M16x2 n.18	M22x1.5 n. 10
606W3	315	200	115	370	330	300	270	280	335	M16x2 n.18	M22x1.5 n. 10

Wheel drives



600WE Series

Bonfiglioli 600WE planetary drives incorporate an integrated, maintenance-free electric motor and offer significant benefits, including compact dimensions, low noise and high efficiency. This advanced powertrain solution uses a two- or three-stage gearbox offering reduction ratios of up to 1:145 to satisfy the widest possible range of needs. The gearbox is coupled with a low-voltage induction motor (BT Series), specially developed for traction power and control applications.



ELECTRIC SOLUTIONS



ACCESS
PLATFORMS



SCISSOR
PLATFORMS



TELESCOPIC
PLATFORMS

Input speed

- up to 6,000 rpm

Main options

- Speed sensor bearing
- Other types of temperature sensors
- Mechanical disengagement for towing, with no need to remove the wheel and without oil drop
- Parking brake (spring applied with hydraulic or electromagnetic release)

Key features

- Two- or three-stage planetary drive with reduction ratios of up to 1:145
- Optimized gear design for maximum efficiency and minimum noise
- Integrated, low voltage, 3 phase induction motor with inverter
- Integrated, high accuracy, KTY temperature sensor
- High resolution, Hall effect speed sensor

Torque (Nm)



Type	Ratios	Max Input Speed	Weight	Oil Quantity	AC Electric Motor - Size				Parking Brake		Machine Ton Class
					BT135	BT150	BT170	BT200	Electromagnetic	Hydraulic	
	1:	rpm	kg	L							ton
600 WE	48- 58.7	6,000	35	0.5	•	•			•		2 ÷ 4
601 RE	20.1 - 51.8	4,000	40	0.8		•	•		•	•	4 ÷ 6
602 RE	20.3 - 30.6	6,000	53	0.7		•	•		•	•	6 ÷ 9
602 WE	20 - 145	6,000	45	0.5		•	•		•	•	6 ÷ 9
604 WE	22.2 - 53	5,000	65	1.1			•	•	•	•	9 ÷ 12
605 WE	22.2 - 53	5,000	65	1.1			•	•		•	12 ÷ 18

	BT 135-			BT 150-			BT 170-			BT 200-		
	50	100	150	50	100	150	50	100	150	50	100	150
P _n (S2 60') (kW)	0.9	1.6	2.3	1.5	2.5	3.4	2.4	4.3	5.4	3.1	6.2	9.1
T _n (Nm)	3	5.6	8.5	4.8	9.1	12.5	7.7	14	22	10	20	29.5
V _{batt} (V)	24	24	24	24	24	24	48	48	48	80	80	80
I _n (A)	55	95	128	80	130	175	67	110	143	53	98	137
n (rpm)	2,930	2,927	2,632	2,894	2,617	2,610	2,945	2,952	2,357	2,957	2,963	2,958
cosφ	0.77	0.8	0.81	0.85	0.86	0.87	0.77	0.83	0.8	0.77	0.8	0.84
η (%)	86.9	89.5	90.0	85.5	88.7	89.2	88.3	89.6	91.3	88.8	91.6	92.5

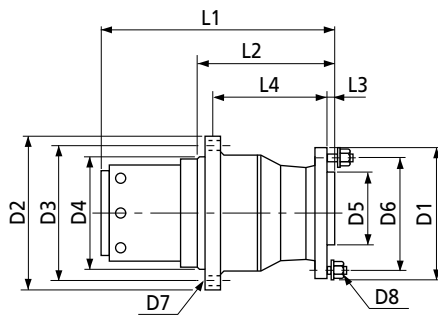

RE version

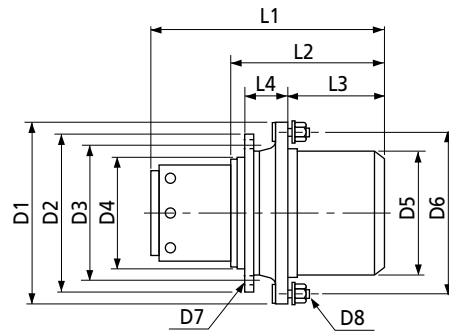

WE version

Type	L1												L2	L3	L4	D1	D2	D3	D4	D5	D6	D7	D8
	BT 135-			BT 150-			BT 170-			BT 200-													
	50	100	150	50	100	150	50	100	150	50	100	150											
600WE	275	325	375	290	340	390	-	-	-	-	-	-	134	39	89	240	207.5	190.5	171.45	184.15	216	M8 n.6	M12 n.9
601RE	-	-	-	-	453	503	412	462	-	-	-	-	247	12	200	189	265	245	225	110	160	Ø13 n.8	M14x1.5 n.8
602RE	-	-	-	-	-	524	434	484	534	-	-	-	269	15	193	210	295	265	235	130	170	M16 n.8	M18 n.6
602WE	-	-	-	-	-	455	375	425	475	-	-	-	210.5	104.5	88	260	271	248	220	200	230	Ø15 n.12	M14 n.9
604WE	-	-	-	-	-	-	-	464	514	446	496	-	231	110	106	315	300	275	250	220	275	M16x2 n.12	M20x1.5 n.8
605WE	-	-	-	-	-	-	-	-	524	456	506	556	241	154	72	315	300	275	250	220	275	M16x2 n.12	M20x1.5 n.8

Slew drives



700T Series

The 700T series slew drives provide the safest and most effective solution to all hydraulic access platforms. 700T units have long been established in the cranes, excavators and special equipment industries, and today are highly appreciated by all the major manufacturers.



HYDRAULIC SOLUTIONS



ACCESS
PLATFORMS



SCISSOR
PLATFORMS



TELESCOPIC
PLATFORMS

Brake options

- Hydraulically released parking brake on request

Applicable motors

- Piston hydraulic motors
- Hydraulic orbit motors
- Electric motors IEC

Motor options

- Pressure relief valve
- Overcenter valve

Key features

- Flange mounted
- Output shaft: splined or with
- Integral pinion
- Rugged construction
- High torque capacity
- Output shafts supported by heavy-duty capacity bearings

Torque (Nm)

700 TF	1,200
701 TF	2,400
703 TF	3,500
705 TF	6,500



Type	Ratios	Max Input Speed	Max Brake Torque at Motor Shaft (Static)	Weight	Oil Quantity	Orbital Hyd. Motor	Hydraulic Piston Motor	Machine Ton Class
	1:	rpm	Nm	kg	L			ton
700 T F	3.48 - 7.2	500	400	22	1	•		4 ÷ 7
701 T F	3.48 - 7.2	500	400	27	1	•		7 ÷ 12
703 T F	3.6 - 44	3,000	400	45	1.5	•	•	12 ÷ 18
705 T F	12 - 44	3,000	400	55	2	•	•	18 ÷ 25

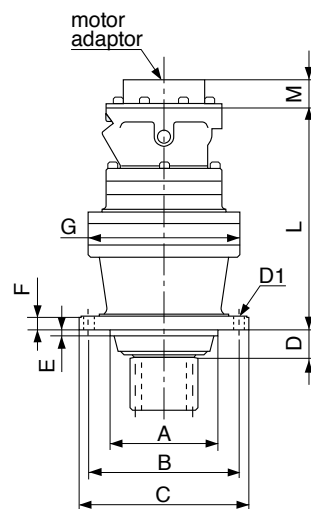

Type	A	B	C	D	E	F	G	L	D1	M
700 T F	150 f7	195	218	31	7	12	186	230 - 280	ø13 n.10	
701 T F	150 f7	195	218	31	7	12	186	250 - 300	ø13 n.10	Based on the motor type
703 T F	175 f7	245	272	41	9	20	245	300 - 350	ø18 n.10	
705 T F	175 f7	245	272	41	9	20	245	320 - 370	ø18 n.10	

Global Presence



Bonfiglioli is a market force with a presence spanning 22 countries on 5 continents. Our organization makes the most of geographic proximity to offer complete solutions combining efficiency and competence.



3700
EMPLOYEES



22
BRANCHES



14
PLANTS



250
DISTRIBUTORS



80
COUNTRIES

We Are a Global Company

Thanks to an international network of sales branches and closely interconnecting production plants, we can guarantee the same high standards of Bonfiglioli quality anywhere at any given time. Aware that our direct presence in local markets is the key to long-lasting success, our family includes 22 sales branches, 14 production plants and more than 500 distributors around the world.

Our organization is always close by, offering complete and efficient solutions and supporting our customers with dedicated services, such as co-engineering or after-sales assistance.



Bonfiglioli Worldwide Locations

Australia

www.bonfiglioli.com.au
2, Cox Place Glendenning NSW 2761
Locked Bag 1000 Plumpton NSW 2761
Tel. +61 2 8811 8000

Brazil

www.bonfigliolidobrasil.com.br
Travessa Cláudio Armando 171 - Bloco 3 - CEP 09861-730
Bairro Assunção - São Bernardo do Campo - São Paulo
Tel. +55 11 4344 2322

China

www.bonfiglioli.cn
Bonfiglioli Drives (Shanghai) Co., Ltd.
#68, Hui-Lian Road, QingPu District,
201707 Shanghai
Tel. +86 21 6700 2000

France

www.bonfiglioli.fr
14 Rue Eugène Pottier
Zone Industrielle de Moimont II - 95670 Marly la Ville
Tel. +33 1 34474510

Germany

www.bonfiglioli.de
Bonfiglioli Deutschland GmbH
Sperberweg 12 - 41468 Neuss
Tel. +49 0 2131 2988 0

Bonfiglioli Vectron

Europark Fichtenhain B6 - 47807 Krefeld
Tel. +49 0 2151 8396 0

O&K Antriebstechnik

Ruhrallee 8-12 - 45525 Hattingen
Tel. +49 0 2324 2050 1

India

www.bonfiglioli.in
Bonfiglioli Transmissions Pvt. Ltd.
Plot No. AC7-AC11, SIDCO Industrial Estate,
Thirumudivakkam - 600 044 Chennai
Tel. +91 44 2478 1035

Industrial

Survey No. 528, Porambakkam High Road,
Mannur Village, Sriperambudur Taluk - 602 105 Chennai
Tel. +91 44 6710 3800
Plot No. A-95, Phase IV, MIDC Chakan, Village Nighoje
Pune, Maharashtra - 410 501

Italy

www.bonfiglioli.it

Headquarters

Bonfiglioli Riduttori S.p.A.
Via Giovanni XXIII, 7/A - 40012 Lippo di Calderara di Reno
Tel. +39 051 647 3111

Mobile, Wind

Via Enrico Mattei, 12 Z.I. Villa Selva - 47100 Forlì
Tel. +39 0543 789111

Industrial

Via Bazzane, 33/A - 40012 Calderara di Reno
Tel. +39 051 6473111
Via Trinità, 1 - 41058 Vignola
Tel. +39 059 768511
Via Sandro Pertini lotto 7b - 20080 Carpiano
Tel. +39 02 985081

Bonfiglioli Mechatronic Research

Via F. Zeni 8 - 38068 Rovereto
Tel. +39 0464 443435/36

New Zealand

www.bonfiglioli.co.nz
88 Hastie Avenue, Mangere Bridge, 2022 Auckland
PO Box 11795, Ellerslie
Tel. +64 09 634 6441

Singapore

www.bonfiglioli.com
24 Pioneer Crescent #02-08
West Park Bizcentral - Singapore, 628557
Tel. +65 6268 9869

Slovakia

www.bonfiglioli.com
Robotnícka 2129
Považská Bystrica, 01701 Slovakia
Tel. +421 42 430 75 64

South Africa

www.bonfiglioli.co.za
55 Galaxy Avenue, Linbro Business Park - Sandton
Tel. +27 11 608 2030

Spain

www.tecnotrans.bonfiglioli.com
Tecnotrans Bonfiglioli S.A.
Pol. Ind. Zona Franca, Sector C, Calle F, nº 6
08040 Barcelona
Tel. +34 93 447 84 00

Turkey

www.bonfiglioli.com.tr
Atatürk Organize Sanayi Bölgesi, 10007 Sk. No. 30
Atatürk Organize Sanayi Bölgesi, 35620 Çiğli - İzmir
Tel. +90 0 232 328 22 77

United Kingdom

www.bonfiglioli.co.uk
Industrial
Unit 7, Colemeadow Road
North Moons Moat - Redditch, Worcestershire B98 9PB
Tel. +44 1527 65022

Mobile, Wind

3 - 7 Grosvenor Grange, Woolston
Warrington - Cheshire WA1 4SF
Tel. +44 1925 852667

USA

www.bonfiglioliusa.com
3541 Hargrave Drive
Hebron, Kentucky 41048
Tel. +1 859 334 3333

Vietnam

www.bonfiglioli.vn
Lot C-9D-CN My Phuoc Industrial Park 3
Ben Cat - Binh Duong Province
Tel. +84 650 3577411



We have a relentless commitment to excellence, innovation and sustainability. Our team creates, distributes and services world-class power transmission and drive solutions to keep the world in motion.

HEADQUARTERS

Bonfiglioli Riduttori S.p.A.
Via Giovanni XXIII, 7/A
40012 Lippo di Calderara di Reno
Bologna (Italy)
tel: +39 051 647 3111
fax: +39 051 647 3126
bonfiglioli@bonfiglioli.com
www.bonfiglioli.com

